

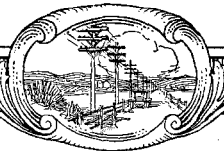

ELECTRICAL COMMUNICATION

October 1939

Volume 18, Number 2



ELECTRICAL COMMUNICATION

A Journal of Progress in the
Telephone. Telegraph and Radio Art

BERNARD C. HOLDING, EDITOR

EDITORIAL BOARD

E. A. Brofos G. Deakin E. M. Deloraine P. E. Erikson F. Gill
W. Hatton R. A. Mack H. M. Pease Kenneth E. Stockton C. E. Strong

Issued Quarterly by the

International Standard Electric Corporation

67 BROAD STREET, NEW YORK, N.Y., U.S.A.

Volume XVIII

October 1939

Number 2

	PAGE
THE HYDROGEN FILLED IRON WIRE BALLAST LAMP.....	115
<i>By R. A. L. Cole and D. P. Dalzell</i>	
THE CALCULATION OF ARTICULATION FOR EFFECTIVE RATING OF TELEPHONE CIRCUITS.....	120
<i>By L. C. Pocock</i>	
THE IMPLOSION OF CATHODE-RAY TUBES.....	133
<i>By C. N. Smyth</i>	
RADIO FREQUENCY HIGH VOLTAGE PHENOMENA.....	135
<i>By Andrew Alford and Sidney Pickles</i>	
THE TOLL BOARD INSTALLATION, CITY OF RIO DE JANEIRO, FEDERAL DISTRICT, BRAZIL.....	150
<i>By W. Hirsch and E. A. Brander</i>	
THE INTERNATIONAL TELECOMMUNICATION CONVENTION.....	160
<i>By F. G. Loring</i>	
MODERN BROADCAST REPEATER EQUIPMENTS.....	168
<i>By R. A. Meers and F. G. Filby</i>	



VALVE DEVELOPMENTS

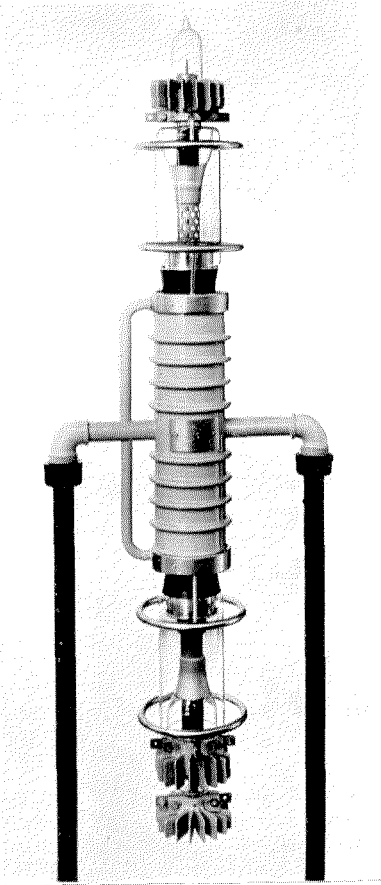

*100 kW double - ended water - cooled
4030-C valve—type in use in a number
of high power transmitters.*

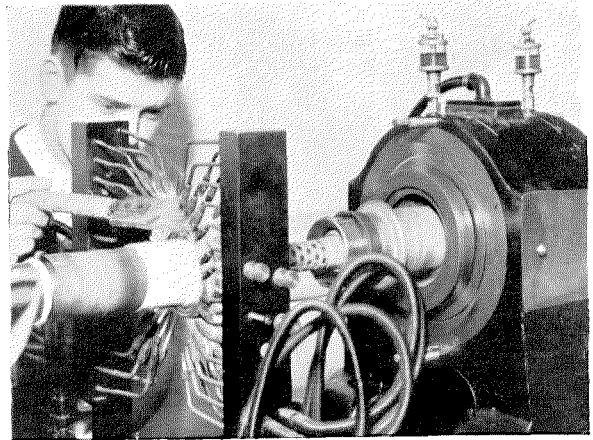

Sealing-in grid end of the 4030-C valve.

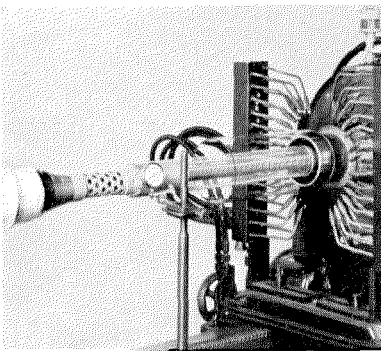

*Aligning grid of 4030-C valve prior to
sealing-in.*

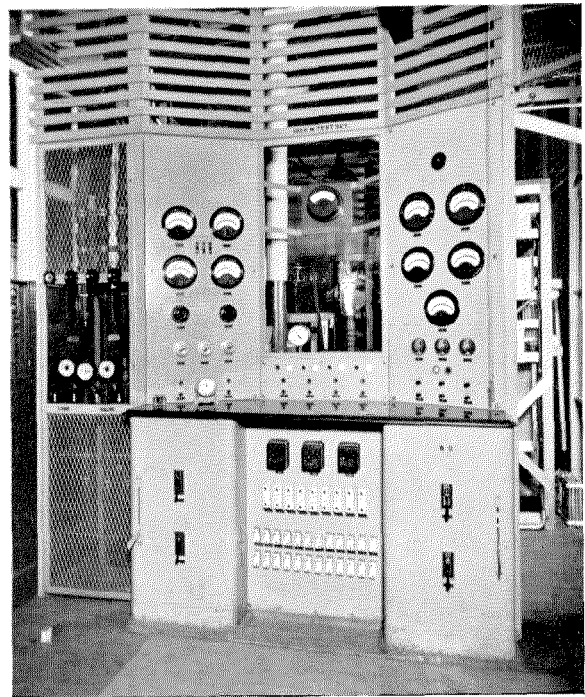

Test station for 4030-C valve.

[Photographs by Standard Telephones & Cables Ltd., London]

The Hydrogen Filled Iron Wire Ballast Lamp

By R. A. L. COLE, B.A., and D. P. DALZELL, A.M.I.E.E..

Standard Telephones and Cables, Limited, London, England

OBSERVATIONS ON THE ACTION OF BALLAST LAMPS

THE iron wire ballast lamp, ballast resistor or barretter, as it is sometimes called, is a device consisting of an iron wire in an atmosphere of hydrogen, for maintaining between very narrow limits the electric current flowing in a circuit, in spite of considerable voltage fluctuations, if the rate of change of voltage is always small.

As the voltage across a ballast lamp is slowly increased from zero, the current through it rises from zero until the ballasting region is reached. As the voltage is further increased the current rises very slowly to a maximum, the filament meanwhile not getting hot enough at any point to emit visible radiation. The current then falls slightly until a portion of the filament is just visible in the dark, reaching a temperature of about 550°C ., when there is a sudden jump in the maximum temperature. At this stage almost the entire filament is quite dark, but a very short portion attains a temperature of about 700°C . and glows quite brightly. This jump in temperature is accompanied by a sudden slight drop in current, and thereafter the current decreases slowly to a minimum and then increases. Meanwhile the length of the glowing portion increases continuously but the maximum temperature of any point of the filament only rises so slowly that a comparatively big change in voltage is required to produce a change in temperature detectable by eye. The ballast action continues until the glowing portion has spread to the whole filament, by which time the maximum temperature is about 800°C . Ballasting thereafter ceases and the current then rises more rapidly as the applied voltage is increased; as the current rises, the maximum temperature of the filament also rises rapidly to the melting point of the wire.

When the voltage is varied up and down very slowly in the neighbourhood of the sudden jump in temperature and current, the change appears to take place reversibly, i.e., at the same voltage whether the voltage is increasing or decreasing.

A typical voltage-current characteristic obtained by the authors is given in Fig. 1.

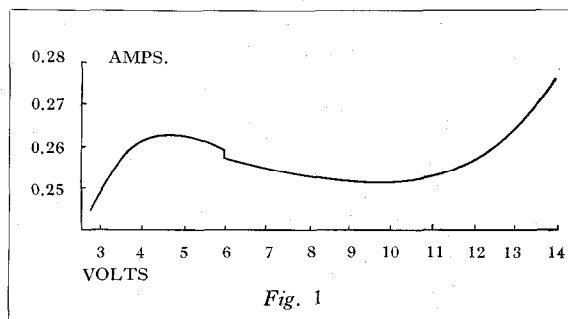

Fig. 1

The most noticeable feature of the operation is the variation in the length of the glowing portion of the filament, with scarcely any change in maximum temperature, as the voltage across the lamp is varied. This feature of ballast lamp operation does not appear to be well known or understood, although it has been dealt with at considerable length in an article by Hans Busch.¹

The following is published in the belief that a considered summary of the theory developed by Busch may interest readers of this journal.

DERIVATION OF THE DIFFERENTIAL EQUATION OF TEMPERATURE DISTRIBUTION

Let us consider for simplicity the case of a long uniform filament of cross-sectional area a

¹ *Ann. der Phys.*, 1921, 4th Series, Vol. 64, No. 5, p. 401.

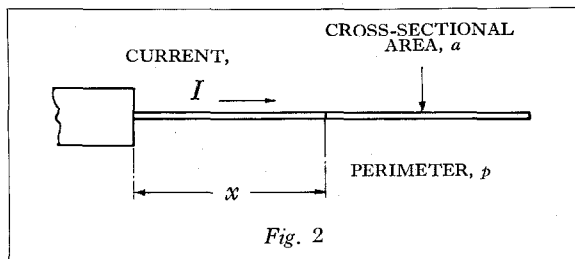

and perimeter p , traversed by a current I and terminated at one end in a cold support (Fig. 2).

If k is the thermal conductivity,
 ρ the electrical resistivity, and
 ψ the heat loss per unit area,

k , ρ and ψ being functions of temperature T , for the steady state the balance between gain and loss of heat is expressed by the following :

$$\frac{d}{dx} \left(ak \frac{dT}{dx} \right) - p\psi + I^2 \frac{\rho}{a} = 0. \dots\dots(1)$$

For points sufficiently far from the support, a maximum temperature T_m is approached and corresponds to the current I in the following manner :

$$I^2 \frac{\rho_m}{a} = p \psi_m. \dots\dots\dots(2)$$

The suffix m indicates that ρ_m and ψ_m are to be taken for a temperature T_m . This condition (2) is characteristic of an infinitely long wire, and for a short wire does not give the maximum temperature quite accurately.

Equations (1) and (2) may be combined to give :

$$\frac{a}{p\psi_m} \cdot \frac{d}{dx} \left(k \frac{dT}{dx} \right) + \frac{\rho}{\rho_m} - \frac{\psi}{\psi_m} = 0.$$

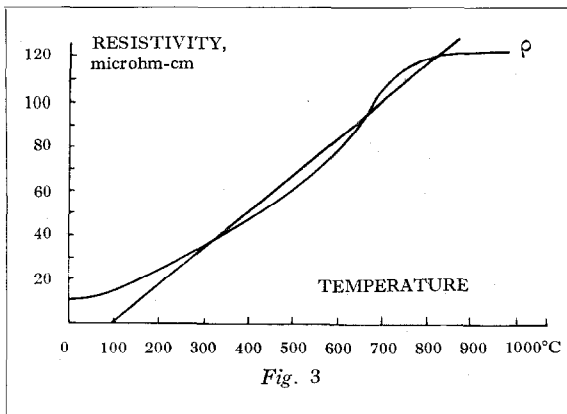

By multiplying by $2k \frac{dT}{dx}$ and integrating,

$$\int_x^\infty \left\{ \frac{a}{p\psi_m} \cdot 2k \frac{dT}{dx} \cdot \frac{d}{dx} \left(k \frac{dT}{dx} \right) \right\} dx + \int_x^\infty \left\{ \frac{\rho}{\rho_m} - \frac{\psi}{\psi_m} \right\} 2k \frac{dT}{dx} dx = 0.$$

Changing the variable for the second integral from x to T ,

$$\frac{a}{p\psi_m} \left(k \frac{dT}{dx} \right)^2 = \int_T^{T_m} 2k \left\{ \frac{\rho}{\rho_m} - \frac{\psi}{\psi_m} \right\} dT$$

or

$$\left(\frac{dT}{dx} \right)^2 = \frac{p}{ak^2} \int_T^{T_m} 2k \left\{ \frac{\psi_m}{\rho_m} - \frac{\psi}{\rho} \right\} dT$$

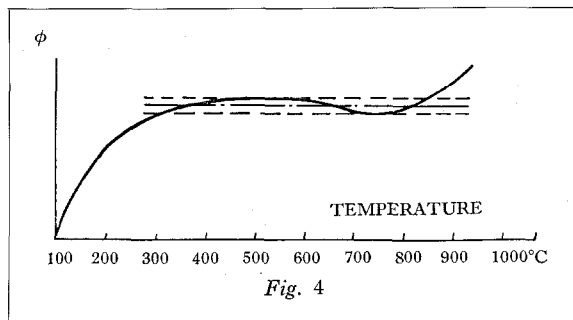

and now, with $\varphi = \frac{\psi}{\rho}$ the required differential equation is obtained,

$$\left(\frac{dT}{dx} \right)^2 = \frac{p}{ak^2} \int_T^{T_m} 2k\rho \left\{ \varphi_m - \varphi \right\} dT. \dots\dots(3)$$

EXAMINATION OF THE CONSEQUENCES OF THE DIFFERENTIAL EQUATION

For a wire in hydrogen, Busch found experimentally that the heat loss is mainly by convection and that ψ is approximately proportional to the temperature difference between the point on the wire considered and the glass bulb. For an iron wire, ρ is approximately as shown in Fig. 3, the data for which are taken from Gmelin's *Handbuch der anorganische Chemie*, 1934, Eisen, Teil A, 1558-1577.

If the temperature of the bulb is in the neighbourhood of 100°C ., and the cooling function can be considered to be a linear

function of temperature as stated above, it will be seen from the straight line drawn on Fig. 3 through the point (100° C., 0) that the graph of φ as a function of temperature will exhibit a shallow maximum followed by a shallow minimum somewhat as in Fig. 4. Any bulb temperature between 0° C. and 300° C. will lead to some similar result, even when its dependence upon the load is considered.

If φ_m is some value of φ between the dotted lines of Fig. 4, the function under the integral sign in (3) must be very similar in form to the function obtained from Fig. 4 by plotting $(\varphi_m - \varphi)$ and in particular must vanish at the same temperatures as the function $(\varphi_m - \varphi)$. This situation is represented approximately in Fig. 5.

The nature of the similarity between the

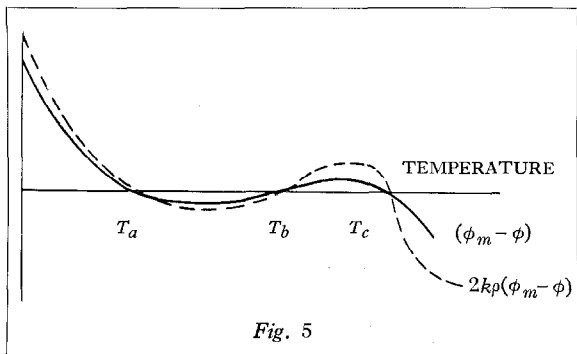

Fig. 5

function under the integral sign in (3) and the function $(\varphi_m - \varphi)$ is illustrated by the dotted curve in Fig. 5, where some arbitrarily varying value of $2k\rho$ is assumed and the ordinates of $(\varphi_m - \varphi)$ are multiplied accordingly.

Considering now the curve $2k\rho(\varphi_m - \varphi)$ there must exist some value of φ_m for which the two areas enclosed between the curve and the temperature axis will be equal, and for a value of φ_m very slightly greater than this, the area above the temperature axis will be very slightly greater than the area below. Let us assume that the value of φ_m already chosen is such a value, and that the dotted curve in Fig. 5 represents the function $2k\rho(\varphi_m - \varphi)$ with this additional property.

As for $T = T_m$, $\varphi = \varphi_m$, the points of intersection of the curves of Fig. 5 with the temperature axis appear to give possible values of T_m . However, of these points, T_b is impossible

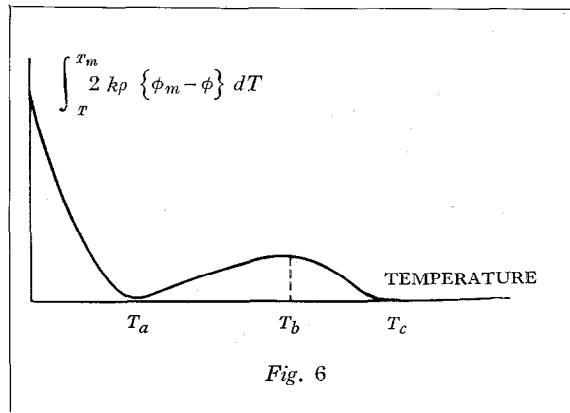

Fig. 6

since, for this point, the integral in (3) from some value of temperature just less than T_b to T_b would be negative. This leaves only T_a and T_c as possible values of T_m .

If T_a is taken, the result is some quite ordinary temperature distribution similar to that obtained with any other heated wire. The temperature distribution in the ballast lamp for the lower voltages, before the jump in temperature previously mentioned has taken place, is of this type.

If, however, T_c is taken, some quite interesting consequences can be deduced.

A general idea of the shape of the curve obtained by integrating the function $2k\rho(\varphi_m - \varphi)$ of Fig. 5 can easily be formed. As the dotted curve cuts the axis at a finite though

possibly small angle that differs from $\frac{\pi}{2}$, the

curve for the integral must touch the temperature axis at T_c . It must have a maximum at T_b and a minimum at T_a . The minimum at T_a must be very nearly zero and positive, as the area above the axis has been chosen to be very slightly greater than the area below. The integral is therefore something like Fig. 6.

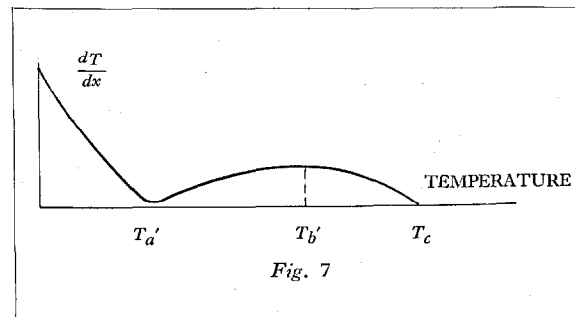

Fig. 7

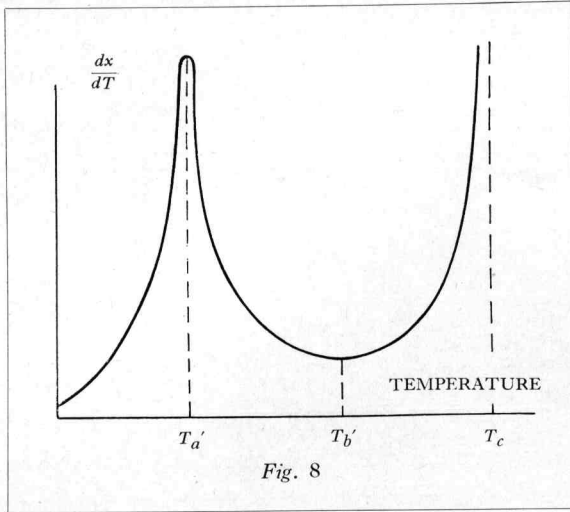

Fig. 8

$\left(\frac{dT}{dx}\right)^2$ is equal to this integral multiplied by $\frac{p}{ak^2}$ and must have the same general form, including contact with the axis at T_c , although the maximum and minimum may be slightly displaced to temperatures $T_{a'}$ and $T_{b'}$ in the neighbourhood of T_a and T_b . As we have no exact idea of its shape, Fig. 6 may be taken equally well to represent $\left(\frac{dT}{dx}\right)^2$ if T_a becomes $T_{a'}$ and T_b becomes $T_{b'}$.

The form of the square root curve, giving

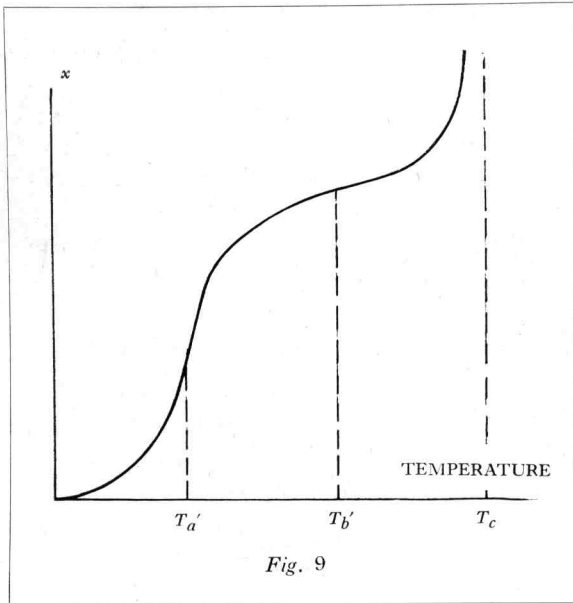

Fig. 9

$\frac{dT}{dx}$, will be similar but it will cut the axis at T_c (Fig. 7).

Its reciprocal (Fig. 8), giving $\frac{dx}{dT}$, will have a high maximum at $T_{a'}$, a minimum at $T_{b'}$ and it will tend to infinity as T approaches T_c .

The relation between x and T is obtained by integrating $\frac{dx}{dT}$ with respect to T ; so, by taking account of the shape of the curve in Fig. 8, we infer that the relation between x and T is represented roughly by the curve shown in Fig. 9.

In the neighbourhood of T_c , $\frac{dT}{dx}$ cuts the axis (Fig. 7) and is of the form $\frac{dT}{dx} = A(T_m - T)$, where A is some constant; therefore,

$$T_m - T = B e^{-Ax}$$

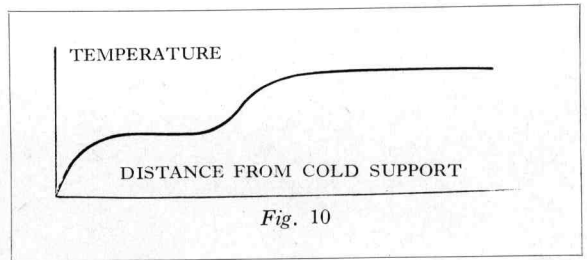

Fig. 10

i.e., T exponentially approaches its limiting value T_m as x increases indefinitely.

Redrawing Fig. 9 with x and T interchanged and changing the scale, something like Fig. 10 is obtained.

Proceeding in a manner similar to the above, commencing with a whole family of $(\varphi_m - \varphi)$ curves, we can deduce the general form of the whole family, of which Fig. 10 is a typical example.

In this way the curves of Fig. 11 were deduced by the authors. Curves 1, 2 and 3 are early members of the family, before ballasting begins. The limiting curve before the jump in temperature takes place is 3, and 4 is a curve of the general shape of Fig. 10 after the jump in temperature.

The initial portion of 4 is deliberately drawn below the initial portion of 3 as, in the deduction of the curves of Fig. 11 from a

family of $(\varphi_m - \varphi)$ curves, there are indications of a sudden drop in the temperature of the end part of the wire simultaneously with the sudden rise in its maximum temperature. This feature of ballast lamp operation has not been investigated further.

Curves 5 and 6 show further successive stages in the ballasting region, while 7 and 8 are two later curves showing how the temperature distribution gradually becomes more normal after the ballasting action has ceased. In 9, which is of the same general shape as 1, 2 and 3, the temperature distribution has become quite normal.

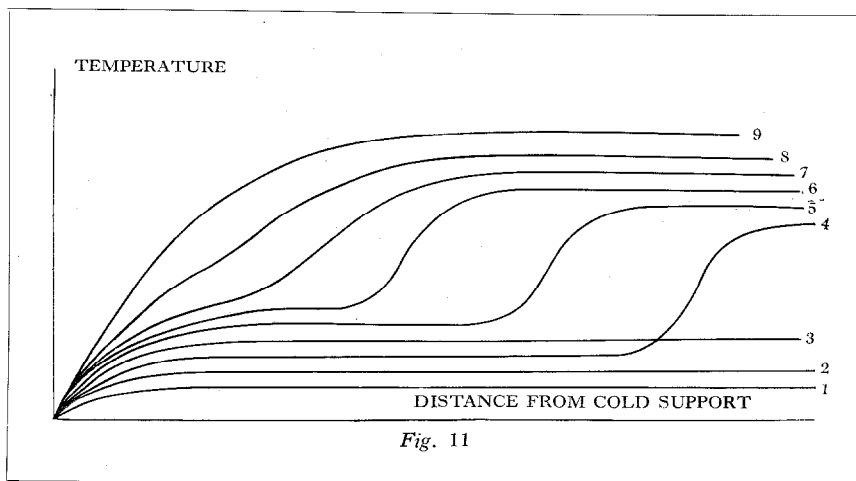

Fig. 11

ρ curve through the $(100^\circ \text{C.}, 0)$ point, which has been taken as the bulb temperature. This can be seen to be in the neighbourhood of 500°C. , as found in practice.

The lowest stable maximum temperature that can exist after the jump cannot be so easily deduced since it corresponds to the point T_c on the curve $2k\rho(\varphi_m - \varphi)$ of Fig. 5 when φ_m has been so chosen as to make the two areas enclosed between the curve and the temperature axis equal. The temperature at which this equality occurs cannot be deduced from Fig. 3 very accurately because of the factor $2k\rho$; but, as $2k\rho$ probably increases with temperature somewhat similarly to ρ , we can conclude that the lowest maximum temperature after the jump will be somewhat below 800°C. It is found in practice to be in the neighbourhood of 700°C.

The agreement between theory and observation can be considered satisfactory when the general nature of the argument is considered, and the discussion seems to afford a good example of the power of general descriptive graphical methods.

CONCLUDING REMARKS

It may be assumed that the preceding analysis applies satisfactorily to the behaviour of a short wire when the hottest portion is of appreciable length, for then the value of $\frac{d^2T}{dx^2}$ is small at the point where the maximum temperature is attained, although for a very short hot spot the analysis can scarcely apply accurately. Nevertheless, deductions can be made concerning the temperature distribution which agree sufficiently well with observation.

The highest temperature attainable in a stable condition, just before the temperature jump takes place, can be roughly deduced from Fig. 3 by noting the lower of the two temperatures at which a tangent can be drawn to the

The Calculation of Articulation for Effective Rating of Telephone Circuits

By L. C. POCOCK, M.Sc., A.M.I.E.E.,

Standard Telephones and Cables, Limited, London, England

IT has long been recognized that the design of telephone circuits on a purely "volume" or loudness basis is inadequate; the volume basis of design goes back to the time when attenuation was the principal problem of long distance transmission; now, line attenuation no longer limits the distance over which transmission can be afforded, and communication engineers are able to concentrate on the problems involved in providing circuits to give a good grade of transmission from every point of view.

A new method of rating circuits is therefore needed to replace the "volume" method, and the new method must take into consideration, in addition to volume, a number of other factors affecting the quality of transmission; as is now well known, a method that is being studied is based upon service observations of the frequency with which subscribers have to make repetitions in order to convey their ideas to the listener.

While there must be many physical and psychological circumstances influencing the frequency of repetitions, it is obvious that two important factors are the level at which speech is received in relation to ambient and line noise interference, and the quality of the received speech which may be measured as articulation percentage or some function of articulation such as intelligibility percentage.

The received speech level relative to noise level depends on many factors which are outside the control of the telephone engineer, or only partly under control; for example, the loudness of the speaker and the position of the transmitter relative to the mouth are somewhat controlled by the amount of side tone, but also by local

noise conditions and personal habits; the noise interference at the receiving end is partly controlled by side tone but the actual noise level is generally uncontrollable. Extensive data must therefore be collected on the effect of received speech level and noise interference on transmission quality.

The quality of the speech received over various types of circuit may be studied in the laboratory by articulation tests, and it has been the practice to make such tests at a more or less constant talking level, thus obtaining a measure of the circuit quality which depends on the circuit only but which does not completely represent the circuit performance. One reason why this practice has been adopted is the absence of adequate information on the talking level used in service under different conditions of side tone and noise.

Noise at the receiving end is frequently introduced when making articulation tests, and it is convenient to think of the noise interference as a part of the speech quality because the interference varies greatly with frequency, and therefore the character or quality of the noise must be taken into consideration.

In various earlier publications a method has been outlined for calculating the articulation of a telephone connection from physical measurements of the circuit and apparatus; such a method is needed in conjunction with information on the received speech level under service conditions in contributing to the study of the new effective rating method, and ultimately for designing the parts of a communication system economically in accordance with a suitable effective rating limit. In this article it is proposed to describe in detail how the articulation

TABLE I

EXAMPLE OF ARTICULATION CALCULATION WITHOUT LINE NOISE OR ROOM NOISE

Circuit : 2 km No. 24 A.W.G. local line each end ; 20 km No. 22 A.W.G. cable plus 20 db. distortionless trunk

Frequency	I.S.I. db. above threshold	Air-to-air loss db.	Received level db. above threshold	p%	SPEAKER			
					MALE		FEMALE	
					Δb E	$p \Delta b$ F	Δb G	$p \Delta b$ H
A	B	C	D					
0-200	88	104	—	—	0.047	—	0.009	—
200-400	109	64	45	75.1	0.056	0.0421	0.023	0.0173
400-600	112	59	53	89.0	0.095	0.0845	0.060	0.0535
600-800	114	57	57	93.5	0.097	0.0907	0.074	0.0691
800-1 000	114	54	60	96.0	0.083	0.0796	0.082	0.0788
1 000-1 200	114	48	66	99.0	0.070	0.0693	0.076	0.0752
1 200-1 400	113	51	62	97.2	0.060	0.0584	0.061	0.0593
1 400-1 600	113	65	48	81.4	0.053	0.0431	0.045	0.0366
1 600-1 800	111	71	40	62.7	0.047	0.0295	0.042	0.0264
1 800-2 000	109	78	31	39.8	0.043	0.0171	0.038	0.0151
2 000-2 200	108	80	28	32.3	0.039	0.0126	0.030	0.0097
2 200-2 400	107	77	30	37.3	0.036	0.0134	0.033	0.0123
2 400-2 600	106	78	28	32.3	0.033	0.0107	0.033	0.0107
2 600-2 800	105	83	22	18.6	0.030	0.0056	0.032	0.0096
2 800-3 000	104	89	15	8.6	0.028	0.0024	0.028	0.0024
3 000-3 200	102	94	8	2.8	0.026	0.0007	0.025	0.0007
3 200-3 400	100	91	9	3.4	0.022	0.0007	0.026	0.0006
3 400-3 600	99	94	5	1.4	0.018	0.0002	0.020	0.0003
3 600-3 800	97	100	—	—	0.015	—	0.019	—
3 800-4 000	95	104	—	—	0.012	—	0.018	—
Total : $p \Delta b \times 100$	56.06	..	47.76
Equivalent sound articulation	89.3	..	85.7
Observed results (corrected)	89.5	..	85.0

is calculated, and to give examples of calculated and observed results.

SUMMARY OF FUNDAMENTAL IDEAS

As may be seen by reference to the earlier publications,* the general basis of calculation is that the recognition of speech sounds depends on the reception of the bands of frequency that compose them, and therefore articulation is a function of the number of received frequency bands. "Sound articulation" *d* is defined as a function of "band articulation" *b*. Δb is a function of frequency and represents the capacity of any narrow frequency band (200 p : s wide) to convey band articulation; finally, when certain frequencies are attenuated, the less intense speech components at those frequencies will be attenuated below the threshold, and consequently only a fraction *p* of the maximum possible Δb

will be received. These considerations lead to the general formula for sound articulation

$$d = f(b) = f [\Sigma p \cdot \Delta b],$$

where the summation is taken over the frequency range transmitted. Δb is a constant for any particular band of frequency 200 p : s wide, but different for different bands, and generally different for male and female speakers. Each value of Δb is multiplied by a fraction *p* which depends solely upon the received level of the speech sounds at the particular frequency region of the Δb .

The received level of the speech sounds is determined by the overall (air-to-air) attenuation of the telephone circuit at any particular frequency, relative to fixed constant values (initial speech intensities of bands—I.S.I.) which represent the maximum intensity above threshold of articulation bands for direct speech.

Finally it is to be noted that for purposes of articulation calculation, the field of speech bands

* See especially reference 2 in Bibliography; also Appendix I.

is comprised between an upper limit representing loud speech (I.S.I.) and a lower limit which is a *minimum* threshold, and therefore lies somewhat below the *average* threshold curve which is elsewhere ordinarily referred to as "the threshold."

CALCULATION OF ARTICULATION IN A SIMPLE CASE

At this point it is convenient to give in full an example of the procedure for calculating the articulation of a telephone circuit when there is no line noise or room noise present.

In Table I the first column names the frequency regions, each 200 p : s wide. Column A gives the level above threshold of the loudest articulation components in each band; these figures are invariable and apply in all calculations. Column B gives the overall air-to-air loss of the circuit being studied; column C is the difference A-B, and therefore gives the received level above threshold of the loudest

articulation components in each band. Column D gives the percentage of speech bands that will be received when the loudest components are at the level indicated in column C; the values of $p\%$ are taken from Table IV. Columns E and G give the maximum contribution to band articulation possible in each 200 p : s band for male and female speakers respectively; the figures are invariable in all calculations. Columns F and H give the respective products $p \Delta b$ whose sum is the calculated band articulation, which can be converted to sound articulation by Table V.

ARTICULATION CALCULATOR

In practice the rather lengthy procedure illustrated in Table I is made very much simpler by using the calculator designed by Dr. J. Collard, illustrated in Fig. 1. To calculate the band articulation for a telephone circuit, it is only necessary to know the overall air-to-air loss for each frequency band. Each sector of

the calculator corresponds to one frequency band such as 800-1 000, and is divided with a scale representing air-to-air loss; the sectors are placed in position so that each one contributes to the circumferential total so much of its scale as lies between the number for the air-to-air loss at the frequency concerned, and the highest number on the scale representing the air-to-air loss at which nothing would be received in that frequency band. When this process has been completed for the whole series of sectors, the total band articulation is read from the uniform circular scale representing the addition of the uncovered parts of the sectors.

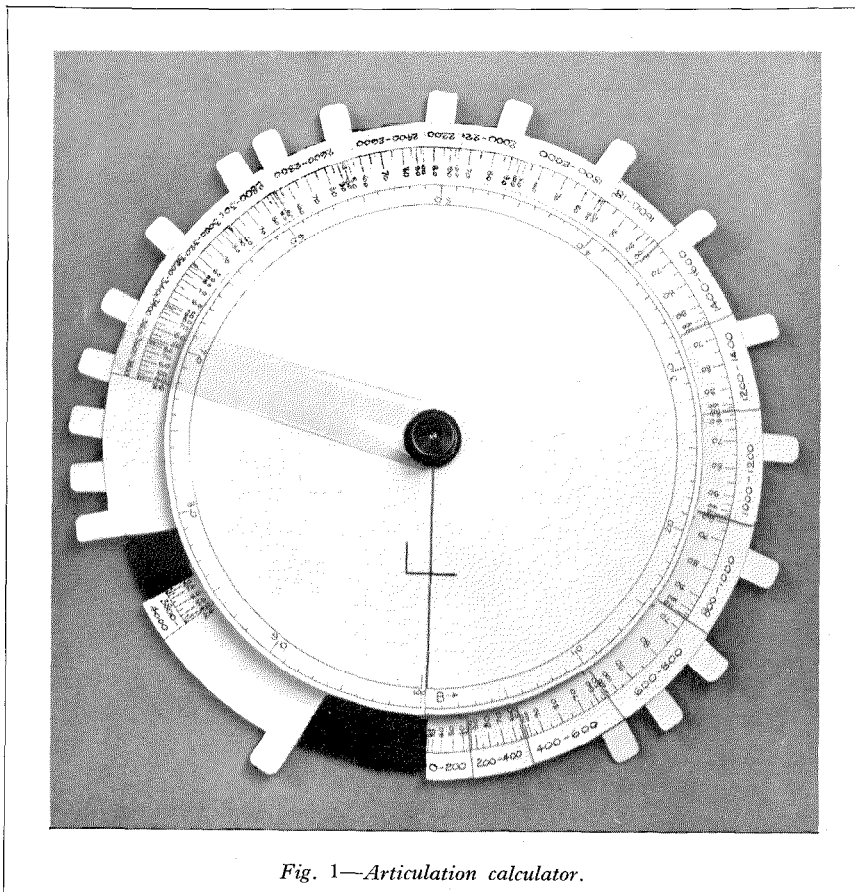
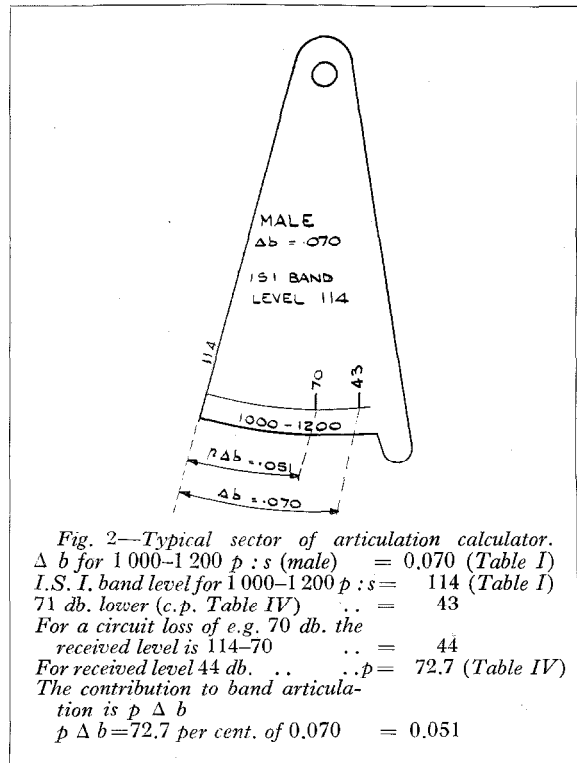

Fig. 1—Articulation calculator.

Fig. 2 shows how a typical sector is constructed. It is evident that the sectors required for male and female speakers are different.

SELF MASKING

The example that has been worked out in Table I is the simplest case occurring. In many commercial circuits, especially over long unloaded cables, the higher speech frequencies are



not only attenuated but are also partly masked by more intense lower frequency speech components. From the basic hypothesis that each speech sound is characterized by one, two or more frequency bands, it may be deduced that one-band sounds will not suffer from self masking, but sounds characterized by two or more bands may have the higher frequency bands more or less masked by bands occurring in the frequency region where the circuit loss is least. If, therefore, the syllable lists used for articulation contain $A\%$ of one-band sounds, then, for a list of 100 sounds, A sounds do not produce self masking, and it is only the remaining $100-A$ sounds that are subject to self masking; the calculated band articulation

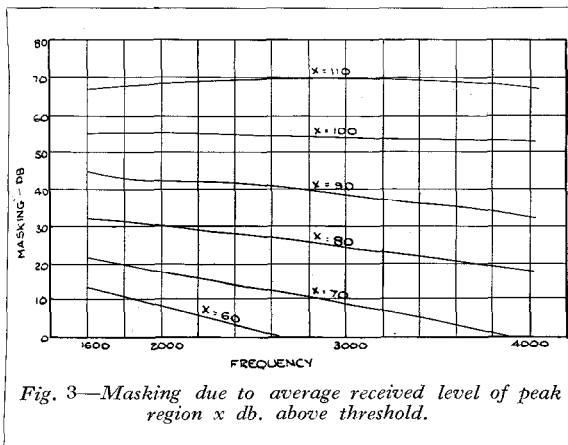

should therefore be derivable from a formula of the type :

$$b = \frac{A}{100} b_1 + \frac{(100-A)}{100} b_m$$

where b_1 is the band articulation calculated without any consideration of masking, and b_m is a result calculated with certain allowances made for masking effects.

In the English syllable lists used in the S.T. & C. laboratories, it is estimated that 72% of the sounds are characterized by a single fre-

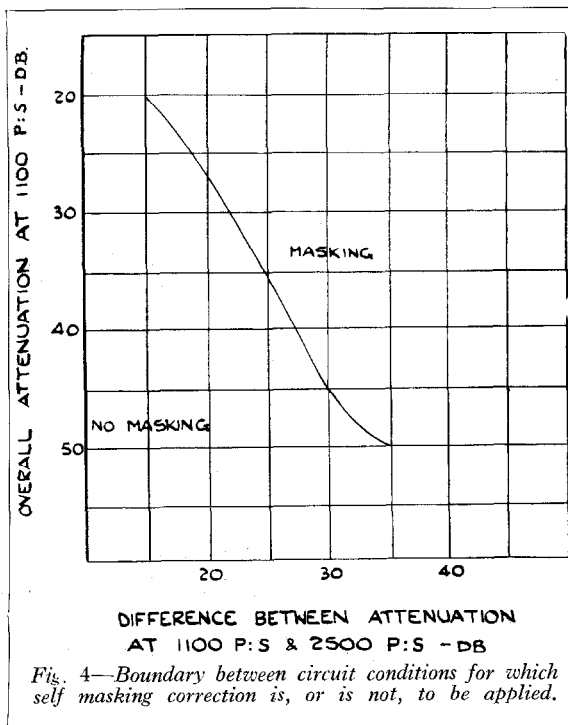

TABLE II

EXAMPLE OF ARTICULATION CALCULATION WITH MASKING BUT NO LINE NOISE OR ROOM NOISE

Circuit : 2 km No. 24 A.W.G. local lines ; 20 km No. 22 A.W.G. cable trunk

Frequency	I.S.I. db. above threshold	Air-to-air loss db.	Received level db. above threshold	p%	SPEAKER				Threshold shift due to masking	Received level above masked threshold	p%	SPEAKER		
					MALE		FEMALE					MALE	FEMALE	
					Δb	p Δb	Δb	p Δb						p Δb
0-200	88	84	4	1.0	0.047	0.0005	0.009	0.0001	—	—	—	0.0005	0.0001	
200-400	109	44	65	98.6	0.056	0.0551	0.023	0.0226	—	—	—	0.0551	0.0226	
400-600	112	39	73	100.0	0.095	0.0950	0.060	0.0600	—	—	—	0.0950	0.0600	
600-800	114	37	77	100.0	0.097	0.0970	0.074	0.0740	Average Masking Level 78.6	—	—	0.0970	0.0740	
800-1 000	114	34	80	100.0	0.083	0.0830	0.082	0.0820		—	—	—	0.0830	0.0820
1 000-1 200	114	28	86	100.0	0.070	0.0700	0.076	0.0760		—	—	—	0.0700	0.0760
1 200-1 400	113	31	82	100.0	0.060	0.0600	0.061	0.0610		—	—	—	0.0600	0.0610
1 400-1 600	113	45	68	99.5	0.053	0.0528	0.045	0.0448	—	—	—	0.0528	0.0448	
1 600-1 800	111	51	60	96.0	0.047	0.0451	0.042	0.0403	30	30	37.3	0.0175	0.0157	
1 800-2 000	109	58	51	86.3	0.043	0.0371	0.038	0.0328	29	22	18.6	0.0080	0.0071	
2 000-2 200	108	60	48	81.4	0.039	0.0317	0.030	0.0244	28	20	15.2	0.0059	0.0046	
2 200-2 400	107	57	50	84.8	0.036	0.0305	0.033	0.0280	27	23	20.5	0.0074	0.0068	
2 400-2 600	106	58	48	81.4	0.033	0.0268	0.033	0.0278	26	22	18.6	0.0061	0.0061	
2 600-2 800	105	63	42	67.7	0.030	0.0203	0.032	0.0216	24	18	12.3	0.0037	0.0039	
2 800-3 000	104	69	35	50.0	0.028	0.0140	0.028	0.0140	23	12	5.5	0.0015	0.0015	
3 000-3 200	102	74	28	32.3	0.026	0.0084	0.025	0.0081	22	6	1.8	0.0005	0.0005	
3 200-3 400	100	71	29	34.8	0.022	0.0077	0.026	0.0091	20	9	3.4	0.0007	0.0009	
3 400-3 600	99	74	25	24.9	0.018	0.0045	0.020	0.0050	19	6	1.8	0.0003	0.0004	
3 600-3 800	97	80	17	11.0	0.015	0.0016	0.019	0.0021	18	—	—	—	—	
3 800-4 000	95	84	11	4.7	0.012	0.0006	0.018	0.0008	16	—	—	—	—	
4 000-4 200	92	88	4	1.0	0.011	0.0001	0.017	0.0002	15	—	—	—	—	
4 200-4 400	90	92	—	—	0.010	—	0.016	—	—	—	—	—	—	
Total p $\Delta b \times 100$	74.18	63.47		Total p $\Delta b \times 100$ with					
Total 72% not masked +28% masked	69.2	58.7		masking 56.50 46.80					
Equivalent sound articulation	93.8	90.3							
Observed results (corrected)	93.5	90.5							

quency band; *A* is therefore given the value 72%.

Masking effects are equivalent to raising the threshold of hearing, and the amount of the threshold change increases with the intensity of the masking noise. In practice the loudest received sounds are in the region of receiver resonance at about 1 000-1 200 p : s and it is the received level in the neighbourhood of this frequency band that determines the amount of masking ; that is, the amount of threshold shift. The semi-empirical practice for calculating b_m is to determine the average air-to-air loss over the frequency range 600-1 600 p : s and select the appropriate masking curve* from Fig. 3 ;

the threshold shifts indicated by the curve are then added to the air-to-air loss for frequencies above 1 600 p : s.

When the overall frequency characteristic of a circuit is almost a constant loss at all frequencies, the conditions approach normal air borne speech in which no self masking occurs ; it is the steep fall in a circuit frequency characteristic that makes self masking possible ; hence a criterion is necessary to determine whether a masking correction is to be applied in any particular case. From a study of numerous results Fig. 4 has been prepared, establishing empirically a boundary between circuit conditions for which masking treatment is, or is not, necessary.

This empirical curve is based on results obtained with only one type of resonant subscribers' apparatus, and is therefore of doubtful

* These are smoothed out curves compiled from published data adjusted to suit the absolute threshold adopted in articulation calculations.

general application. On the other hand, the characteristics of the newer types of subscribers' telephone apparatus are such that self masking conditions are not likely to occur.

In Table II an example including self masking is worked out; the procedure is the same as before but, on account of the higher received level, the self masking of received sounds must be considered. The air-to-air loss at 1 000-1 200 p : s is 28 db., and the difference between this and the air-to-air loss at 2 400-2 600 is 30 db.; hence, consulting the empirical relationship of Fig. 4, masking must be taken into account. It will be seen that the band articulation is calculated as in the earlier example; the subsequent procedure is to determine the average received level in the region 600-1 600 p : s (-78.6 db.) and, in accordance with the curves of Fig. 3, to add losses representing a rise in threshold level to the air-to-air loss for

all frequencies above 1 600 p : s. The sum of $p \Delta b$ is then redetermined taking the additional losses into account. Finally, the band articulation is taken as 72% of the direct band articulation plus 28% of the masked articulation.

ROOM NOISE AND LINE NOISE

The effect of room noise and line noise is to raise the threshold of hearing by an amount which is generally called the masking of the noise. Recent publications† indicate that the masking curve can be calculated when the noise spectrum is known, but in the case of room noise the calculation is complicated by the existence of two noise paths, namely, the side tone path and the air path through the earcap leakage. At present the threshold shift caused by line noise and room noise is being measured

† See Bibliography.

TABLE III

EXAMPLE OF ARTICULATION CALCULATION WITH MASKING AND NOISE

Circuit : 2 km No. 24 A.W.G. local lines; 20 km No. 22 A.W.G. cable trunk
Line Noise : 0.23 mV Psophometric P.D. across 200 ohm receiver—thermal noise

Frequency	Received level from Table II	Threshold shift due to line noise	Received level above noise level	p%	SPEAKER				Received level with self masking from Table II	p% for self masking from Table IV	SPEAKER	
					MALE		FEMALE				MALE	FEMALE
					Δb	$p \Delta b$	Δb	$p \Delta b$			$p \Delta b$	$p \Delta b$
0-200	4	15	—	—	0.047	—	0.009	—	—	—	—	
200-400	65	18	47	79.5	0.056	0.0445	0.023	0.0183	—	—	0.0445	0.0183
400-600	73	30	43	70.2	0.095	0.0667	0.060	0.0421	—	—	0.0667	0.0421
600-800	77	31	46	77.4	0.097	0.0750	0.074	0.0571	—	—	0.0750	0.0571
800-1 000	80	35	45	75.1	0.083	0.0623	0.082	0.0615	—	—	0.0623	0.0615
1 000-1 200	86	29	57	93.5	0.070	0.0654	0.076	0.0710	—	—	0.0654	0.0710
1 200-1 400	82	31	51	86.3	0.060	0.0518	0.061	0.0526	—	—	0.0518	0.0526
1 400-1 600	68	23	45	75.1	0.053	0.0398	0.045	0.0338	—	—	0.0398	0.0338
1 600-1 800	60	22	38	57.7	0.047	0.0271	0.042	0.0242	30	37.3	0.0175	0.0157
1 800-2 000	51	13	38	57.7	0.043	0.0248	0.038	0.0220	22	18.6	0.0080	0.0071
2 000-2 200	48	10	38	57.7	0.039	0.0225	0.030	0.0173	20	15.2	0.0059	0.0046
2 200-2 400	50	8	42	67.7	0.036	0.0244	0.033	0.0226	23	20.5	0.0074	0.0068
2 400-2 600	48	12	36	52.6	0.033	0.0174	0.033	0.0174	22	18.6	0.0061	0.0061
2 600-2 800	42	11	31	39.8	0.030	0.0120	0.032	0.0127	18	12.3	0.0037	0.0039
2 800-3 000	35	9	26	27.3	0.028	0.0076	0.028	0.0076	12	5.5	0.0015	0.0015
3 000-3 200	28	9	19	13.7	0.026	0.0036	0.025	0.0034	6	1.8	0.0005	0.0005
3 200-3 400	29	5	24	22.6	0.022	0.0050	0.026	0.0059	9	3.4	0.0007	0.0009
3 400-3 600	25	2	23	20.5	0.018	0.0037	0.020	0.0041	6	1.8	0.0003	0.0004
3 600-3 800	17	—	17	11.0	0.015	0.0016	0.019	0.0021	—	—	—	—
3 800-4 000	11	—	11	4.7	0.012	0.0006	0.018	0.0008	—	—	—	—
4 000-4 200	4	—	4	1.0	0.011	0.0001	0.017	0.0002	—	—	—	—
Total $p \Delta b \times 100$					55.59		47.67				45.71	38.39
Total 72% not self masked + 28% self masked					53.0		45.0					
Equivalent sound articulation					88.1		84.2					
Observed results (corrected)					88.9		85.3					

by means of a variable exploring tone which is adjusted to be just audible, first, in the presence of the noise, and, second, when the noise is absent; the difference between the two adjustments is taken as the threshold shift due to the noise at the frequency of the exploring tone.

As this subjective measurement is relative to the average threshold of the crew, while the data used for calculating articulation is based on an extreme limiting threshold, it is to be expected that something must be added to the measured threshold shift to make it relative to the threshold used elsewhere in the calculations. For the crew used it was found that the observed threshold shifts should be increased by 4 db. to give the best agreement between observed and calculated articulation.

Table III gives a calculation for a circuit with line noise in which masking is also considered. The threshold shift due to noise is added to the air-to-air loss since the object is to determine the received level above the threshold in the presence of the noise. In considering the self masking, the threshold shifts due to self masking must be added directly to the air-to-air loss (without noise) because they are not due in any way to the presence of the noise. If, how-

TABLE IV
VALUES OF p%

Received Level	p%	Received Level	p%	Received Level	p%
71	100	47	79.5	23	20.5
70	99.9	46	77.4	22	18.6
69	99.7	45	75.1	21	16.8
68	99.5	44	72.7	20	15.2
67	99.3	43	70.2	19	13.7
66	99	42	67.7	18	12.3
65	98.6	41	65.2	17	11.0
64	98.2	40	62.7	16	9.8
63	97.7	39	60.2	15	8.6
62	97.2	38	57.7	14	7.5
61	96.6	37	55.2	13	6.5
60	96	36	52.6	12	5.5
59	95.3	35	50.0	11	4.7
58	94.5	34	47.4	10	4.0
57	93.5	33	44.8	9	3.4
56	92.5	32	42.3	8	2.8
55	91.4	31	39.8	7	2.3
54	90.2	30	37.3	6	1.8
53	89.0	29	34.8	5	1.4
52	87.7	28	32.3	4	1.0
51	86.3	27	29.8	3	0.7
50	84.8	26	27.3	2	0.4
49	83.2	25	24.9	1	0.2
48	81.4	24	22.6	0	0

TABLE V
RELATION BETWEEN BAND ARTICULATION AND SOUND ARTICULATION

b	d%	b	d%	b	d%	b	d%
0.00	0	0.25	67.6	0.50	86.8	0.75	95.4
0.01	8.0	0.26	68.7	0.51	87.3	0.76	95.6
0.02	13.5	0.27	69.8	0.52	87.7	0.77	95.8
0.03	18.5	0.28	70.9	0.53	88.1	0.78	96.0
0.04	23.5	0.29	72.0	0.54	88.5	0.79	96.2
0.05	28.0	0.30	73.0	0.55	88.9	0.80	96.4
0.06	31.3	0.31	74.0	0.56	89.3	0.81	96.6
0.07	34.7	0.32	75.0	0.57	89.7	0.82	96.8
0.08	37.2	0.33	75.9	0.58	90.1	0.83	97.0
0.09	39.7	0.34	76.7	0.59	90.5	0.84	97.2
0.10	42.2	0.35	77.5	0.60	90.9	0.85	97.3
0.11	44.7	0.36	78.3	0.61	91.3	0.86	97.4
0.12	47.0	0.37	79.1	0.62	91.6	0.87	97.5
0.13	49.0	0.38	79.8	0.63	91.9	0.88	97.7
0.14	51.0	0.39	80.5	0.64	92.2	0.89	97.9
0.15	53.0	0.40	81.2	0.65	92.5	0.90	98.1
0.16	54.6	0.41	81.8	0.66	92.8	0.91	98.3
0.17	56.3	0.42	82.4	0.67	93.1	0.92	98.5
0.18	58.0	0.43	83.0	0.68	93.4	0.93	98.7
0.19	59.6	0.44	83.6	0.69	93.7	0.94	98.9
0.20	61.0	0.45	84.2	0.70	94.0	0.95	99.1
0.21	62.4	0.46	84.8	0.71	94.3	0.96	99.3
0.22	63.8	0.47	85.3	0.72	94.6	0.97	99.5
0.23	65.1	0.48	85.8	0.73	94.9	0.98	99.7
0.24	66.4	0.49	86.3	0.74	95.2	0.99	99.9

ever, the air-to-air loss plus the threshold shift caused by self masking is in any band greater than the air-to-air loss plus noise shift, the received level with noise is to be taken as the masked received level, since the noise masking exceeds the self masking.

TRANSMITTER AND RECEIVER CHARACTERISTICS

The determination of the overall air-to-air loss of a circuit includes the measurement of the transmitter and receiver frequency characteristics, characteristics which, admittedly, have not as yet been determined entirely satisfactorily. It is not therefore proposed to discuss these measurements in great detail.

The receiver characteristics were measured on an artificial ear which included resistance in its acoustic impedance. Several forms of artificial ear were tried, and that one was selected which agreed best with various subjective and objective checks. Much work, however, remains to be done on this subject.

In measuring carbon transmitter characteristics consideration must be given, on account of non-linear behaviour, to the sound intensity at which the sensitivity is measured. Because

TABLE VI

Local Lines km Gauge	Trunk	Cut-off (if any)	No. of Tests	SOUND ARTICULATION					
				MALE SPEAKER			FEMALE SPEAKER		
				Cal- culated	Observed	Differ- ence	Cal- culated	Observed	Differ- ence
6/24	0	—	2	95.8	95.2	0.6	92.7	90.8	1.9
6/24	0	3 100	2	95.2	95.2	0	91.8	90.3	1.5
6/24	0	2 900	3	94.6	93.7	0.9	91.1	88.9	2.2
6/24	0	2 500	4	93.6	92.1	1.5	89.9	86.6	3.3
6/24	10 db.	—	2	95.2	96.0	-0.8	92.0	93.0	-1.0
6/24	10 db.	3 100	2	94.5	94.6	-0.1	91.3	90.2	1.1
6/24	10 db.	2 900	3	94.0	93.7	0.3	90.6	90.8	-0.2
6/24	10 db.	2 500	2	93.2	93.0	0.2	89.3	87.9	1.4
6/24	20 db.	—	2	94.1	94.3	-0.2	91.2	91.1	0.1
6/24	20 db.	3 100	2	93.7	94.7	-1.0	90.5	89.3	1.2
6/24	20 db.	2 900	2	93.4	93.5	-0.1	89.9	90.9	-1.0
6/24	20 db.	2 500	2	92.5	92.5	0	88.7	87.7	1.0
6/24	8/22	—	2	94.2	93.3	0.9	90.8	90.8	0
6/24	8/22	3 100	2	93.9	92.7	1.2	90.3	89.5	0.8
6/24	8/22	2 900	2	93.7	93.0	0.7	90.0	88.3	1.7
6/24	8/22	2 500	2	93.0	92.1	0.9	89.1	87.6	1.5
6/24	8/22+10 db.	—	2	92.5	92.5	0	89.0	89.8	-0.8
6/24	8/22+10 db.	3 100	3	92.5	92.2	0.3	88.7	89.3	-0.6
6/24	8/22+10 db.	2 900	2	92.4	93.0	-0.6	88.6	90.3	-1.7
6/24	8/22+10 db.	2 500	2	91.9	92.4	-0.5	87.9	88.2	-0.3
6/24	8/22+20 db.	—	2	89.7	89.8	-0.1	85.8	87.4	-1.6
6/24	8/22+20 db.	3 100	2	89.5	89.3	0.2	85.7	86.2	-0.5
6/24	8/22+20 db.	2 900	2	89.4	88.9	0.5	85.6	85.5	0.1
6/24	8/22+20 db.	2 500	2	89.6	89.7	-0.1	85.1	84.5	0.6
6/24	10 db.	—	1	96.3	96.4	-0.1	93.7	93.0	0.7
6/24	10 db.	3 100	1	95.9	94.4	1.5	93.1	91.2	1.9
6/24	10 db.	2 900	1	95.4	94.7	0.7	92.4	91.9	0.5
6/24	10 db.	2 500	1	94.3	94.4	-0.1	91.2	89.9	1.3
6/24	20 db.	—	1	94.8	95.3	-0.5	91.9	93.1	-1.2
6/24	20 db.	3 100	1	94.3	93.2	1.1	91.4	90.7	0.7
6/24	20 db.	2 900	1	94.0	93.7	0.3	90.9	91.7	-0.8
6/24	20 db.	2 500	1	93.0	93.6	-0.6	89.3	89.3	0
6/24	8/22+10 db.	—	2	94.2	95.0	-0.8	91.1	92.4	-1.3
6/24	8/22+10 db.	3 100	2	94.0	95.1	-1.1	90.6	92.6	-2.0
6/24	8/22+10 db.	2 900	2	93.7	92.8	0.9	90.3	90.5	-0.2
6/24	8/22+10 db.	2 500	2	92.9	92.8	0.1	89.1	91.6	-2.5
6/24	8/22+20 db.	—	2	91.0	89.3	1.7	87.3	87.3	0
6/24	8/22+20 db.	3 100	2	90.9	91.1	-0.2	87.0	85.4	1.6
6/24	8/22+20 db.	2 900	2	90.9	91.6	-0.7	86.8	88.3	-1.5
6/24	8/22+20 db.	2 500	2	90.2	87.1	3.1	86.0	87.5	-1.5
2/24	20/22	—	2	93.3	93.5	0.3	90.3	90.5	-0.2
2/24	20/22+10 db.	—	1	92.3	93.0	-0.7	88.0	88.7	-0.7
2/24	20/22+20 db.	—	1	89.3	89.5	0.2	85.7	85.0	0.7
2/24	20/22+30 db.	—	1	83.3	83.3	0	78.3	79.8	-1.5
2/24	20/22+35 db.	—	1	78.3	80.7	-2.4	74.9	76.2	1.3
2/24	24 db.	—	2	96.7	96.5	0.2	94.6	92.6	2.0
2/24	34 db.	—	2	95.2	94.7	0.5	92.3	91.1	1.2
2/24	44 db.	—	2	91.1	90.1	1.0	88.4	87.5	0.9
2/24	54 db.	—	1	82.9	79.3	3.6	81.2	78.7	2.5
4/24	20/22	—	2	92.2	91.9	0.3	88.0	88.2	-0.2
Average difference				0.7	1.1
Estimated average error in observed result				0.35	0.51

Improved quality transmitter and receiver

speech sounds at the higher frequencies have lower intensity than at, say, 1 000 p : s, it seemed reasonable to measure the sensitivity with different intensities at different frequencies; the following values were adopted for the free

field intensity at the modal point of the transmitter. ‡

‡ The high pressures required for measuring the sensitivity at the low frequencies were not actually obtainable with the apparatus used ("bars" = dynes per sq. cm.).

f	bars	f	bars	f	bars	f	bars
100	224	1100	56	2100	20	3100	9
300	200	1300	45	2300	16	3300	8
500	112	1500	40	2500	14	3500	7
700	89	1700	28	2700	13	3700	5.5
900	70	1900	22	2900	11	3900	5

These figures are consistent with the data used for initial speech intensity of bands in the calculation of articulation, with the assumption that the appropriate level for measuring the sensitivity is approximately 10 db. below the highest speech band intensity occurring at that frequency.

NON-LINEAR DISTORTION

This present article is concerned with articulation at constant volume and no attention is paid to non-linear distortion except by selecting, as already described, the conditions under which the frequency characteristic of the transmitter is measured. With changes of voice level, it would be reasonable to measure the transmitter sensitivity at correspondingly higher or lower levels; more thorough investigation of the

results obtained by this method are postponed until more is known of the conditions under which transmitter characteristics ought to be measured to correspond with service conditions.

EXPERIMENTAL MEASUREMENT OF ARTICULATION

The experimental measurement of the articulation results given in Tables VI, VII and VIII was carried out with a crew of 5 men and 5 women, the women being used all the time as listeners, but both men and women being employed as speakers.

Volume indicator observations of the talking level were made throughout the tests, and the speakers were allowed to use a natural speaking level. Modal gauges were fixed to the transmitters.

At the talking end, room noise and side tone effects were absent, but at the listening end, side tone was effective when room noise was present.

CREW CALIBRATION

For purposes of crew calibration frequent

TABLE VII

Local Lines km Gauge	Trunk	Cut-off (if any)	No. of Tests	SOUND ARTICULATION						
				MALE SPEAKER			FEMALE SPEAKER			
				Cal- culated	Observed	Differ- ence	Cal- culated	Observed	Differ- ence	
6/24 Transmitting End	40 db. and high quality Receiver	—	2	89.5	89.7	-0.2	86.6	85.2	1.4	
6/24 Transmitting End	„	LP.1550	2	76.3	77.3	-1.0	72.1	73.3	-1.2	
6/24 Receiving End	High quality Transmitter and 40 db.	—	3	95.2	95.5	-0.3	92.0	92.7	-0.7	
6/24 Receiving End	„	LP.1550	3	85.8	86.3	-0.5	80.7	84.9	-4.2	
High quality System	50 db.	—	1	95.6	97	-1.4	92.8	95.6	-2.8	
„	60 db.	—	1	90.5	89.3	1.2	88	88.9	-0.9	
„	40	2500	3	94.9	94.8	0.1	91.4	93.2	-1.8	
„	40	2900	3	95.8	95.8	0	92.6	94.3	-1.7	
„	40	3100	3	96.2	97	-0.8	93.3	94.4	-1.1	
Average difference				0.6	1.8
Estimated average error in observed result				0.35	0.40

TABLE VIII

Local Lines km Gauge	Trunk km Gauge	Noise	No. of Tests	SOUND ARTICULATION					
				MALE SPEAKER			FEMALE SPEAKER		
				Cal- culated	Observed	Differ- ence	Cal- culated	Observed	Differ- ence
		<i>Room Noise</i>							
2/24	30 db.	36 Ph. C	2	94.0	93.4	0.6	90.8	91.9	-1.1
"	"	48 Ph. T	3	94.9	94.4	0.5	91.6	92.0	-0.4
"	"	55 Ph. T	3	91.3	90.9	0.4	87.0	88.4	-1.4
"	"	63 Ph. T	3	79.9	79.8	0.1	77.3	76.5	0.8
"	"	66 Ph. F	3	83.6	83.4	0.2	—	—	—
		Average difference				0.4			0.9
		Estimated Average Error in observed result				0.34			0.42
		<i>Line Noise</i>							
2/24	30 db.	1.05 mV B	4	82.6	83.7	-1.1	80.0	80.3	-0.3
"	"	0.5 mV T	1	86.7	89.4	-2.7	83.8	83.9	-0.1
"	"	0.3 mV B	2	89.7	94.0	-4.3	86.5	89.0	-2.5
"	"	0.25 mV B	3	91.1	91.3	-0.2	87.9	89.3	-1.4
"	"	B	1	81.3	80.6	0.7	76.9	78.7	-1.8
"	"	B	1	65.1	66.4	-1.3	—	—	—
2/24	20/22 db.	0.65 mV R	1	78.5	78.6	-0.1	75.6	76.2	-0.6
"	"	0.65 mV R	1	81.8	78.1	3.7	78.7	72.3	6.4
"	"	0.24 mV R	1	87.7	86.3	1.4	84.1	83.1	1.0
"	"	0.24 mV R	1	88.1	88.1	0	84.9	83.5	1.4
"	"	0.25 mV C	3	93.3	93.3	0	91.2	90.4	0.8
"	"	0.23 mV C	2	88.1	88.9	-0.8	84.2	85.3	1.1
"	"	0.07 mV C	2	92.1	92.3	-0.2	88.7	89.1	-0.4
		Average difference				1.3			1.5
		Estimated Average Error in observed result				0.7			0.78
		LINE NOISE AND ROOM NOISE							
2/24	30 db.	48 Ph. T	3	89.7	91.3	-1.6	87.3	88.0	-0.7
		0.25 mV B							
"	"	48 Ph. T	1	86.3	88.1	-1.8	83.0	85.6	-2.6
		0.25 mV B							
"	"	48 Ph. T	1	80.1	80.5	-0.4	76.9	78.3	-1.4
		1.05 mV B							
"	"	56 Ph. T	2	83.1	81.5	1.6	80.7	76.5	4.2
		0.22 mV B							
"	"	52 Ph. T	2	84.8	84.2	0.6	83.3	81.9	1.4
		0.47 mV B							
"	"	52 Ph. T	2	78.6	76.7	1.9	75.4	74.7	0.7
		1.05 mV B							
		Average difference				1.2			1.8
		Estimated Average Error in observed result				0.7			0.78

- C = Carbon transmitter noise.
- T = Thermal noise.
- F = Fan noise.
- B = Buzzer noise (various arrangements used).
- R = Ringing current noise.

NOTE.—The mV are psophometric millivolts across 200-ohm receiver, but neither these figures nor the room noise figures are to be taken as more than an approximate indication of the noises used.

tests were made on a high quality circuit with an L.P.1550 p:s filter; this circuit was assigned the values $b = 0.510$ for male speakers and $b = 0.462$ for female speakers. The ratio of the observed b value for the calibration to the ideal value is the crew factor by which con-

temporarily observed b values on other circuits must be divided.

DISCUSSION OF RESULTS

In considering the agreement that may reasonably be expected between subjective

observations such as articulation percentages, and calculated values of the same quantity, it is necessary to bear in mind that the crew used for the experimental work is too small to make any claim to being really representative of a large number of telephone subscribers. Further, the fundamental data on which the calculations are based was determined entirely for male speakers, and partly for female speakers, from tests made with different crews. The crew members used in the present observations differed widely in their ability as listeners (see Appendix II); individual listeners gave articulation percentages differing over an average range of about 5%; the lowest and highest results were practically invariably given by listeners S and P respectively, the other three listeners' observations lying within a range of about 1%. The characteristic differences in listeners' ability are shown in Fig. 5; the abscissae are ratios of errors made by each listener to the average errors of the whole crew in each of 48 tests.

A second consideration is the accuracy of the observed data; here "accuracy" means closeness of the observed result to the result that would have been obtained if many more tests had been made. In Tables VI, VII and VIII there is a column for "number of tests," each "test" consisting of 1 600 syllables received; examination of the discrepancy between cal-

culated and observed results classified according to the number of tests shows that the figures draw closer together as the tests increase from one to three. As only two tests were used for the majority of cases, there are appreciable variations from "accuracy" in the observed results; this is further illustrated by failure, in some cases, to obtain a smooth plot from a series of related results.

In order to have a measure of accuracy for the observed data, the approximate value of the expected average error is given for each Table; this has been estimated taking into consideration the percentage articulation and the number of tests made for each result given. The average difference between calculated and observed articulation is generally about twice the estimated average error in the observed results; two exceptions are notable, the male speaker results in the first part of Table VIII where a much higher standard is reached coincident with a high average number of tests for each figure, and the female speaker results in Table VII where, on circuits involving high quality apparatus, the standard of agreement is very poor owing to the calculated result being consistently on the low side.

A study of the results on the lines indicated above leads to the conclusion that calculated results for male speakers will be accurate to an average error of about 0.5% if the noise data, when required, is very carefully determined. For female speakers an average error of about 1% in a calculated result seems a reasonable expectation. These conclusions are based on the tendency of the discrepancy between calculation and observation to decrease as the number of tests increases; the conclusions are moreover very general in character, as the error of both calculated and observed results varies with the articulation percentage concerned.

It is reasonable to expect that there is scope for improvement in calculated results as progress is made in the method of measuring transmitter and receiver characteristics. Meanwhile calculation of articulation is being applied in the effort to discover whether received loudness and articulation can be jointly related to observed values of repetition rate in service circuits.

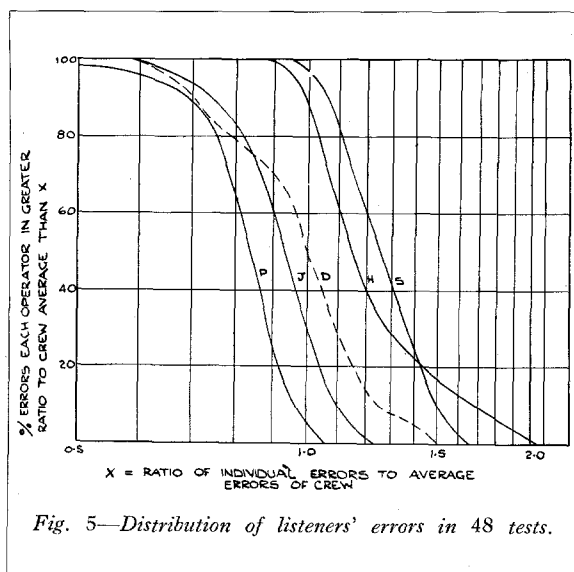

Fig. 5—Distribution of listeners' errors in 48 tests.

APPENDIX I

TABLE IX

% ERRORS IN REPEATED TESTS ON ONE CIRCUIT ANALYZED BY LISTENERS

Test	LISTENER				
	D	H	P	S	J
1	14.85	16.35	10.55	15.05	13.60
2	14.40	16.00	12.10	16.40	14.00
3	14.05	14.55	11.40	15.80	14.40
4	13.85	14.55	11.50	16.35	15.55
5	13.05	15.55	11.05	17.65	15.00
6	12.60	16.60	9.35	16.80	14.25
7	16.90	15.65	11.50	17.75	13.30
8	15.80	16.10	10.55	19.15	13.05
9	18.40	14.10	11.10	17.10	12.85
10	14.85	13.60	10.05	17.75	13.20
Average	14.87	15.30	10.91	16.98	13.92
M.V.	1.19	0.88	0.63	0.89	0.72

The data required for the calculation of articulation may be divided into two parts :—

- (1) The fundamental invariable data which remains the same whatever the circuit conditions considered.
- (2) The specific circuit data describing the conditions under consideration.

Tables I, II and III show in detail how these two sets of data are used in combination, but it may be useful to enumerate separately the items involved.

The invariable data consists of :—

- (a) Figures for the level above threshold of the loudest speech bands in each narrow frequency band of direct speech ; these are known as I.S.I. of bands (initial speech intensity of bands) and are quoted in column A of Table I.
- (b) Figures for the percentage of speech bands received when the received level is a given number of decibels above threshold ; this data is given in Table IV.
- (c) Values of the maximum possible contribution to band articulation in each frequency region ; these are the Δb values in columns E and G of Table I.
- (d) The criterion to determine whether self

masking must be considered, given in Fig. 4.

- (e) The threshold shift caused by self masking, given in Fig. 3.
- (f) The relation between band articulation and sound articulation given in Table V.

The variable circuit data are the overall or air-to-air attenuation of the circuit, and the threshold shift

due to the total noise at the receiving end.

The invariable data, *b*, *c* and *f* above depend on the composition of the syllable lists used for articulation and could not be expected to give calculated results in agreement with results observed when using syllable tests substantially different in make up from the English syllable lists with which they have been established.

APPENDIX II

Ideal Articulation and Crew Factor

In the foregoing article, ideal articulation has been defined as a result obtained by a very large crew free from incidental errors ; it is perfectly reasonable to suppose that under such conditions a stable maximum articulation would exist for any circuit tested, and it is evident that any method of calculating articulation must aim at establishing corresponding stable values. The real difficulty lies in establishing the relation

TABLE X

AVERAGE % ERRORS FOR EACH TALKER IN 10 TESTS WITH 4 LISTENERS

	TALKER									
	MALE					FEMALE				
	M	W	T	SK	B	D	H	P	S	J
Average	13.97	14.82	14.16	13.16	15.76	12.89	16.88	13.85	14.27	14.23
M.V.	1.55	0.80	1.72	1.12	3.17	1.64	1.13	1.14	1.43	1.62

between the results obtained by a small crew and the supposed result that would be obtained by a larger representative crew.

Individuals differ widely in the results they obtain in articulation tests, as is shown by the analysis in Tables IX and X of 10 tests on a high quality circuit with an L.P. 1 550 p : s filter (see also Fig. 5).

The results tabulated were obtained at intervals over a period of six months. Table IX shows the average result and mean variation obtained by each listener with four male and four female speakers. Table X shows the final averages and mean variations for a similar analysis of the same results arranged by talkers. Examination of these Tables shows that each listener has a certain capability of understanding the received sounds, and attains a high degree of constancy in the majority of the tests.

For practical reasons as well as co-ordination between test conditions and average service conditions, the ideal crew that would give an ideal result should not be supposed to consist of individuals all capable of giving the highest results (e.g., SK as talker and P as listener). It is probable that the ability of P as a listener is quite exceptional, for it should be noticed that the greatest number of errors made in any test by this listener is less than the best result obtained by any other observer in any test.

If the whole crew is supposed to be representative of a larger number (a supposition for which there is, of course, no evidence), it would be at least theoretically possible to set up a crew of individuals all equal in ability to P and so perhaps obtain results above the values regarded as ideal.

The conclusions drawn are that no very definite value can be assigned to "ideal articula-

tion" and that it is sufficient to correct observed results to some higher value which represents the ideal for a crew of a certain composition; in particular, for the crew or crews on whose results the data for calculating articulation is based.

As the calibration values are not in themselves precise, since the number of tests made for calibration is restricted by the necessity of making other tests on the same day, they cannot be expected to cover day to day variations. However, they do give some idea of the long period fluctuation of crew capacity, especially during training.

There can be little doubt that the best procedure is what is coming to be known as the interleaved method of testing, in which a fairly short test is made on the calibration circuit or some other comparison condition directly preceding or following the test on the circuits studied, without any of the crew members leaving their positions.

BIBLIOGRAPHY

1. "A Theoretical Study of the Articulation and Intelligibility of a Telephone Circuit," J. Collard, *Electrical Communication*, Vol. 7, January, 1929, p. 168.
2. "Calculation of the Articulation of a Telephone Circuit from the Circuit Constants," J. Collard, *Electrical Communication*, Vol. 8, January, 1930, p. 141.
3. "A New Criterion of Circuit Performance," J. Collard, *Electrical Communication*, Vol. 11, April, 1933, p. 226.
4. "The Practical Application of the New Unit of Circuit Performance," J. Collard, *Electrical Communication*, Vol. 12, April, 1934, p. 270.
5. "Telephone Transmission Testing by Subjective Methods," W. West, *P.O.E.E. Journal*, Vol. 31, Part 4, January, 1939, p. 286.
6. "Relation between Loudness and Masking," H. Fletcher and W. A. Munson, *Journal of the Acoustic Society of America*, Vol. 9, July, 1937, p. 1.

The Implosion of Cathode-Ray Tubes

By C. N. SMYTH, B.Sc. (Eng.), Mem. I.R.E.,

Kolster-Brandes, Limited, London, England

IT has been recognized for some time that the reception of television programmes is fraught with a certain element of risk, due to "implosion" or inward collapse of the large cathode-ray tubes, the front walls of which constitute the television screen. This possibility, while slight in practice, has been considered sufficiently important to warrant discussion amongst television receiver manufacturers. Implosion may be caused by a mechanical fault or by impact near the front of the tube.

The danger, while remote, arises from the fact that when a cathode-ray tube implodes, the fragments of the glass bulb are impelled towards the centre of the vacuum, and thus attain sufficient velocity to make them overshoot the mark and scatter in all directions with considerable force. Fortunately, the implosion of a cathode-ray tube is a very rare occurrence, and so far does not seem to have resulted in serious injury to

anyone. However, the risk of flying glass reaching the viewer and causing injury, particularly to the eyes, is always present. Television receiver manufacturers in consequence have come to realize the necessity of mounting cathode-ray tubes in such a way that no broken glass can emerge from the cabinet.

With a view to establishing the best means of guarding viewers from the danger of tube implosion without at the same time impairing their view of the television screen, the Television Receiver Laboratories of Kolster-Brandes Limited, London, recently made an experimental investigation of the implosion phenomenon. This investigation covered a series of tests in which several 12-inch cathode-ray tubes were mounted in a console receiver cabinet and

exploded by rifle fire through a hole in the side and in line with the edge of the television screen, i.e., the front wall of the tube where the diameter is maximum. In each test the neck of the tube was securely clamped at the back

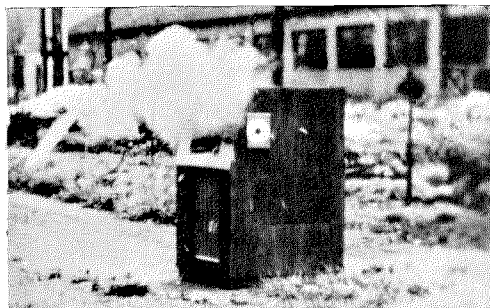
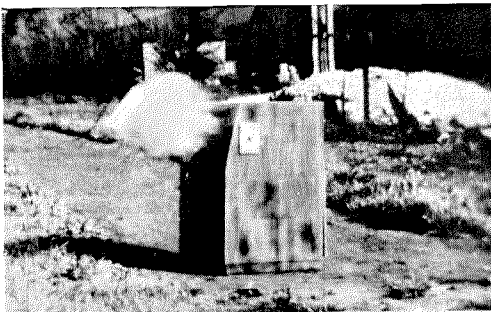

Successive stages in the shattering of an unsatisfactory television receiver protective assembly.

of the cabinet between wooden brackets lined with felt, whilst the front of the tube was supported by a rubber ring surrounding the screen opening and carrying a protecting sheet of plate glass.

The tests proved conclusively that adequate protection against tube implosion is only to be obtained if the protective cover is made of so-called "armour-plate" glass at least one-quarter of an inch thick, mounted behind and extending beyond the screen opening. Ordinary plate glass, as well as celluloid and other transparent synthetic materials (partly due to electrostatic effects), proved to be quite unsuitable.

The accompanying reproductions were made

from motion-picture photographs, and illustrate successive stages in the shattering of an unsatisfactory protective assembly in which the expulsion of the plate-glass cover from the cabinet opening is clearly visible. The magnitude of the forces brought into play by tube implosion may be judged from the fact that in such cases the glass cover and parts of the cathode-ray tube were thrown as much as 12 feet in front of the cabinet.

As the result of these investigations the Kolster-Brandes Television Receiver Laboratories were enabled to prepare specifications for the manufacture and assembly of television receivers effectively eliminating danger due to tube implosion.

Modern Business Management

MODERN business management should be, and I believe for the most part is, imbued with an interest in the public welfare. It provides the basis of satisfaction to educated men, for industry is the basis of the well-being of the nation and commerce, the chief hope of an economy in which the nations of the world can live in peace. Business is not a simple calling. It requires skill of a high order, capacity and a sense of responsibility. Business to-day is not based on the conception of a world of a limited amount of goods in which, if one man gets more, another man must get less. Its objective, whether conscious or not, is to create more for all. And in doing so it must reconcile the interests of the workers, the owners and the consumers. Especially to-day it must carry on with sympathetic understanding of the necessary restrictions to its complete freedom that grow out of what is called the "public interest"—the interest of the general public, whether or not workers, owners or customers of the particular industry.

From an address by Walter S. Gifford at the Commencement Exercises of Union College, June 12, 1939, reprinted from the "Bell Laboratories Record," July, 1939.

Radio Frequency High Voltage Phenomena*

By ANDREW ALFORD,

Mackay Radio and Telegraph Co., New York, N. Y.,

and

SIDNEY PICKLES, Associate A.I.E.E.,

Mackay Radio and Telegraph Co., Half Moon Bay, California

DURING the many years that large amounts of power have been transmitted over long power lines at high voltage, an enormous amount of work has been done on research and development in connection with the high voltage low frequency phenomena encountered. In the years that followed, the use of low radio frequencies for communication purposes brought about the need for knowledge of high voltage phenomena in the region of 100 kilocycles and up to about 200 kilowatts. The men associated with this equipment did a remarkably good job of design on their equipment, as may be seen in some of the apparatus still in use, especially in regard to the large antenna insulators used on the long wave antennae.

When vacuum tubes made the generation of much higher radio frequencies possible, and it was found that the shorter waves transmitted intelligence more efficiently over long distances, the use of large amounts of power for radio transmitters was discontinued, first, because there was no equipment available to produce so much power and, second, because the more efficient propagation of the shorter waves and the more efficient vacuum tube receiving equipment provided a satisfactory means of communication with lower power. This being the case, very high voltages at radio frequencies faded into the background.

With the progression of the art, equipment capable of handling larger and larger amounts

of power up to the ultra-high radio frequencies has been developed in order to provide an ever better means of communication between the remotest parts of the globe. With the increasing power has come the problem of voltage stress, but only in proportion to about the square root of the energy used; hence the high voltage difficulties have lagged the development considerably until recently. Voltages presently in use in high powered transmitters are sufficient to cause frequent dielectric breakdowns, but in most cases the problems have been side-stepped by over designing, or what was thought to be so, in order that concentrated effort could be put on other more pressing problems, and also because there were apparently no tools for accurate measurement of the quantities involved.

Since the advent of high power, high frequency transmitters, and of simultaneous operation of antennae on several frequencies, the issue of high voltage radio frequency phenomena has again come to the foreground. Voltages well over 50 000 R.M.S. volts have been developed in Coupled Sections¹ under test conditions, and in the near future probably several times these values will be common. With the issue of insulation coming to the foreground, a simple and accurate method of high voltage measurements seems to be a necessity. The basis of such a method has been with the electrical art ever since the development of accurate transmission line equations, the principle of the method lying in the relation between voltage and current separated by a quarter-wavelength of transmission line. The relation is simply that the voltage on the line at any point is equal

* Paper presented at the combined summer and Pacific coast convention of the A.I.E.E., San Francisco, California, June 26-30, 1939; together with related discussion that will be published in the 140 volume of *A.I.E.E. Transactions*. It is reprinted here with the permission of the A.I.E.E.

¹ See "Coupled Networks," by Andrew Alford, *I.R.E.*, 1938.

to the surge impedance times the current at a point exactly one quarter-wavelength distant, either toward the receiving or transmitting end, assuming no line losses. This relation holds regardless of the line terminations, the only requisite being that the surge impedance of the line over the quarter-wave region be constant.

The relation referred to was described by Steinmetz in 1908 in his *Transient Electric Phenomena and Oscillations*. Steinmetz's derivation follows:

Given the general transmission line equations:²

$$I = A_1 \epsilon^{+\alpha l} (\cos \beta l - J \sin \beta l) - A_2 \epsilon^{-\alpha l} (\cos \beta l + J \sin \beta l)$$

²Equation 17, page 287, *Transient Electric Phenomena and Oscillations*, by Steinmetz.

$$E = \sqrt{\frac{z}{y}} \left[A_1 \epsilon^{+\alpha l} (\cos \beta l - J \sin \beta l) + A_2 \epsilon^{-\alpha l} (\cos \beta l + J \sin \beta l) \right]$$

For simplification we can assume line losses to be zero and also let E_0 be the voltage at $l = 0$, the reference point on the line. The $\sqrt{\frac{z}{y}}$

becomes $\sqrt{\frac{L}{C}} = z_0$, commonly known as the surge impedance. At the reference point

$$I_0 = (A_1 - A_2)$$

$$E_0 = z_0 (A_1 + A_2)$$

At a point $\frac{\lambda}{4}$ distant, $\beta l = \frac{\pi}{2}$ at which point I_1 and

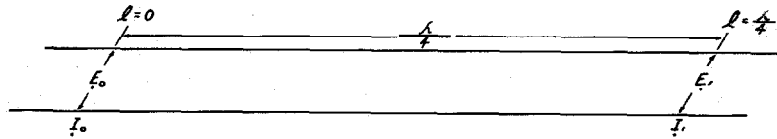

General Transmission Line Equations

$$I = A_1 \epsilon^{+\alpha l} (\cos \beta l - J \sin \beta l) - A_2 \epsilon^{-\alpha l} (\cos \beta l + J \sin \beta l)$$

$$E = \sqrt{\frac{z}{y}} \left[A_1 \epsilon^{+\alpha l} (\cos \beta l - J \sin \beta l) + A_2 \epsilon^{-\alpha l} (\cos \beta l + J \sin \beta l) \right]$$

See *Transient Electric Phenomena and Oscillations*, by Steinmetz.

Assume line losses = 0

$$\text{Then } \alpha = 0 \text{ and } \sqrt{\frac{z}{y}} = \sqrt{\frac{L}{C}} = z_0$$

At $l = 0$

$$I_0 = A_1 (\cos 0 - J \sin 0) - A_2 (\cos 0 + J \sin 0) = (A_1 - A_2)$$

$$E_0 = z_0 \left[A_1 (\cos 0 - J \sin 0) + A_2 (\cos 0 + J \sin 0) \right] = z_0 (A_1 + A_2)$$

$$\text{At } l = \frac{\lambda}{4}, \beta l = \frac{\pi}{2}$$

$$I_1 = A_1 \left(\cos \frac{\pi}{2} - J \sin \frac{\pi}{2} \right) - A_2 \left(\cos \frac{\pi}{2} + J \sin \frac{\pi}{2} \right) = -J (A_1 + A_2)$$

$$E_1 = z_0 A_1 \left(\cos \frac{\pi}{2} - J \sin \frac{\pi}{2} \right) + A_2 \left(\cos \frac{\pi}{2} + J \sin \frac{\pi}{2} \right) = -J z_0 (A_1 - A_2)$$

$\therefore E_1 = -J z_0 I_0$ and when only absolute magnitudes are concerned $E_1 = z_0 I_0$

Fig. A—General transmission line equations.

E_1 shall represent the current and voltage

$$I_1 = -J (A_1 + A_2)$$

$$E_1 = -J z_0 (A_1 + A_2)$$

From which it follows that $E_0 = -J z_0 I_1$

which reduces to $E_0 = Z_0 I_1$ when only absolute magnitudes are considered. This simple derivation turns the quarter-wave line into a radio frequency voltmeter.

Since Z_0 occurring in the above relation is usually of the order of 600 ohms, it follows that high voltages and high currents go together. Both may be produced very simply by means of the arrangement shown in Fig. 1, in which a quarter-wavelength of line is suspended below

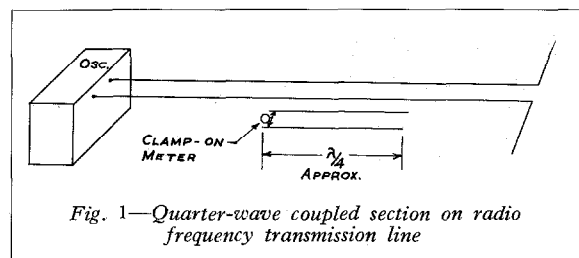

Fig. 1—Quarter-wave coupled section on radio frequency transmission line

an energized transmission line, one end of the quarter-wave line being closed by an adjustable short. If the section is very loosely coupled to the line, that is, hung a foot or two below the line, the current in the short will be found to be very large, since there is only a small amount of resistance present to stop the flow. As pointed out above, the voltage at the open end of the section, being one quarter-wavelength away from the large current, will also be large, and will be the absolute value of the product of the current by the surge impedance of the section.

Experience has shown that this particular arrangement led to trouble due to the difficulty of insulating the open end of the section. This was eliminated by a much more satisfactory arrangement, shown in Fig. 2A, in which a half-wave section of transmission line shorted at both ends and suspended in a plane not parallel to the plane of the energized transmission line is resonated to the frequency on the line by moving one or both of the shorts until maximum current flows in the section. An arrangement of this sort may be provided with supports near or beyond the short where the voltage is low,

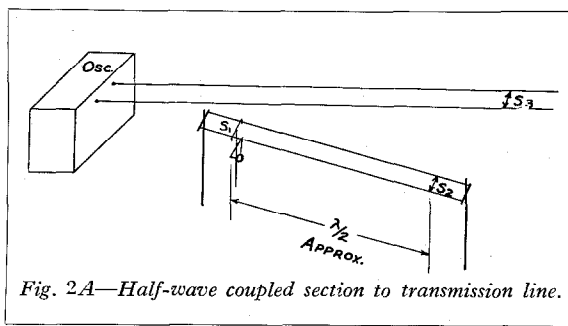

Fig. 2A—Half-wave coupled section to transmission line.

thus presenting no support insulation difficulties. Such a half-wave section may be made, for example, of Number 6 copper wire with the upper short fixed for current measurement and the lower one adjustable for tuning the section, seeing that the lower short is easily accessible. The current in the fixed short may be measured by a clamp-on meter, or, much more conveniently, by an inductively coupled meter which will be referred to as a shortometer, and is shown in Fig. 3. The calibration and theory of this instrument is described in Appendix A, but it is to be noted here that such a meter reads R.M.S. values; hence all currents or voltages referred to in the following will be R.M.S. or effective in magnitude.

The power which is required for producing high voltages up to 60 000 volts is very moderate, being of the order of 10 kilowatts. The loop resistance of the half-wave section at frequencies of the order of 13 megacycles is around one

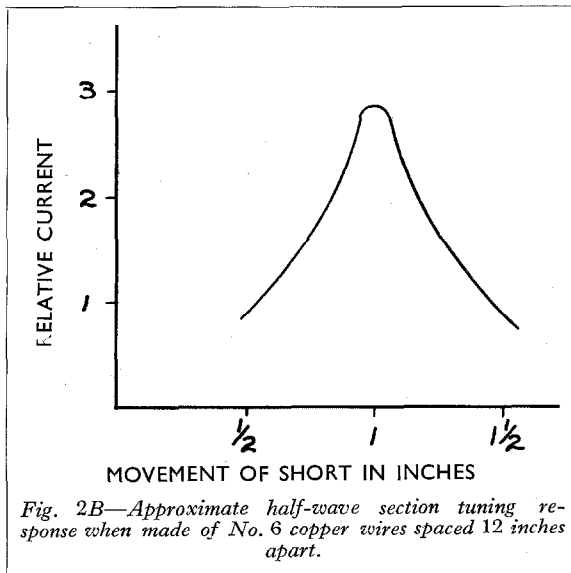
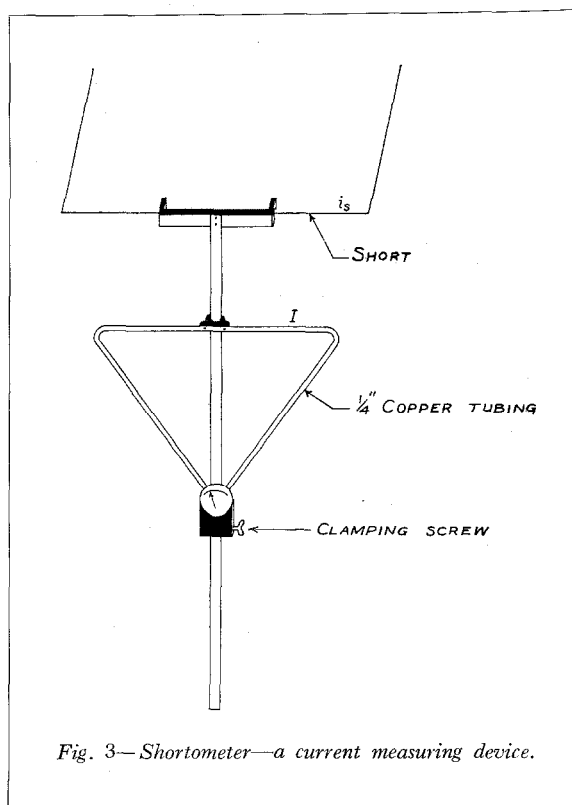
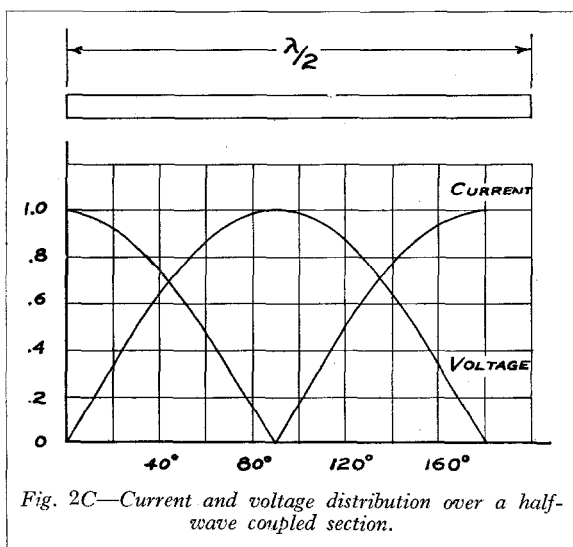

Fig. 2B—Approximate half-wave section tuning response when made of No. 6 copper wires spaced 12 inches apart.

ohm with Number 6 copper wire, so that, if all of the line power is diverted into the section, the current developed in the short is approximately equal to the square root of the power in watts; so when the section is dissipating 10 000 watts, the current in the short would be about 100 amperes. With wires of the section spaced twelve inches apart, the surge impedance is 600 ohms; thus the voltage in the centre of the half-wave section is about $600 \times 100 = 60\,000$ volts, which, as a matter of fact, is somewhat higher than the arcing voltage of the clean Number 6 wires spaced twelve inches apart. When higher voltages are desired, it is necessary to make the half-wave section of larger diameter wire or of tubing.

The best position of short S_3 in Fig. 2A depends on the geometrical configuration of the transmission line and the half-wave section. When the short S_1 of the section is about a foot below the line and the section is inclined at about 15 degrees, it is possible to find a position of short S_3 which, when the half-wave section is nearly in tune, reduces the standing waves along the transmission line to reasonable proportions so that the transmitter is able to deliver power. The best position of this short depends on how much additional resistance is introduced into the section by, say, a sample insulator under test placed across the section. Thus short S_3 is made readily adjustable. This short is then used as a kind of mutual coupling control or adjustable transformer ratio.



HIGH VOLTAGE PHENOMENA

The first phenomenon usually encountered with the half-wave section, as the movable short approaches the resonant point and the current increases to 25 or 30 amperes, is that a flame, somewhat similar to a bunsen burner flame, and about 6 to 8 inches long, shoots into space from some point near the middle of the section. Such flames are usually directed upward and blow very easily in the wind to a point of low voltage where they go out. Immediately another flame spurts out from near the centre of the section and repeats the process. If the section has considerable slant with respect to the ground, the flames will usually run up the wire even if there is no wind blowing, and will go to the low voltage point unless they strike a projection or sharp point, where they will stop moving and will maintain themselves until the power is dropped or the section is detuned. If the wire of the section has a coating of corrosion from the weather, the voltage which the section can stand may be as low as 15 000 or 20 000 volts. This voltage can be doubled or raised even higher before an arc is produced if the

wire is made clean and bright by sanding and wiping with a cloth. It is also interesting to note at this point that, if the shorts are taken off and a 60-cycle voltage is applied across the section, the region which has been cleaned shows no corona, while the parts remaining dirty glow with intense and spotty corona.

It is of particular importance to note the striking contrast that exists between 60 cycle phenomena and 13 000 kc phenomena in regard to the mechanics of the voltage breakdown of the wires. At 60 cycles, as the voltage is gradually increased, first a very faint corona glow develops. As the voltage rises and the corona becomes more intense, streamers shoot out from the wires, and finally they become long enough to bridge the gap between the wires terminating in complete breakdown or arc-over. This process is seen to progress in a more or less continuous manner from no indication of voltage through gradual steps to complete arc-over between wires. Such is not the case at 13 000 kc. When the voltage on the section is gradually raised, there is no indication of increasing voltage stress preceding the arc into space. As soon as the voltage gets up to a certain critical value, an arc occurs, not between wires, but suddenly shoots into space just as if the whole voltage had been instantly applied, there being no noise and no sign of corona accompanying the gradual rise in voltage.

The voltage that a given wire will take at 13 000 kc under the same clean surface conditions varies considerably from day to day, apparently depending on atmospheric conditions. Occasionally sections made of clean, smooth Number 6 wires spaced twelve inches apart will stand as much as 45 000 volts under the best of atmospheric conditions. One of the strangest phenomena of all is the action of smoke from rubbish or grass fires. Wherever the smoke strikes a high voltage region of the section, a

jagged, crackling spark shoots out, and, if the smoke distribution is uniform, the voltage rating of the section will sometimes drop to as low as 20 per cent. of the normal rating, depending on the concentration of smoke.

The electrostatic field near the midpoint of the half-wave section when a large current is flowing in the shorts is quite extensive and produces some curious effects; for example, considerable diathermy effect can be felt in one's legs when standing at least 4 or 5 feet away. The magnetic field about the short also produces some curious phenomena. If a piece of Number 6 wire is fastened on to a wooden handle with iron nails bent around the wire to provide an adjustable short, the nails get red hot, while the current in the wire is sufficient to raise the temperature of the latter only a little above atmospheric.

HIGH VOLTAGE MEASUREMENTS

The voltage which occurs between the conductors of the half-wave section may be applied across what may be termed "samples under test" such as needle gaps, sphere gaps, insulators, condensers, etc. These samples are fastened to sections at a distance of one quarter-wavelength from the fixed short in which the current is observed. Due to the capacity of the sample the movable short has to be translated

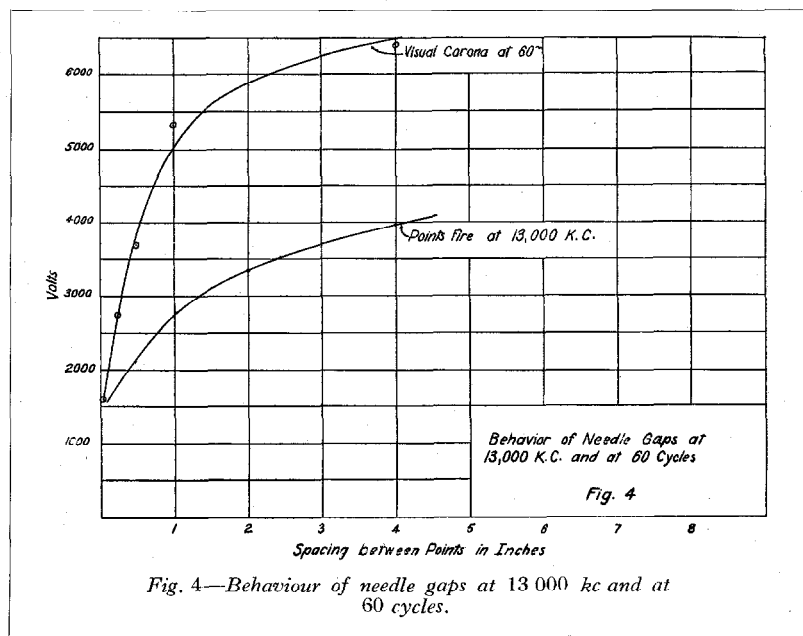

Fig. 4.—Behaviour of needle gaps at 13 000 kc and at 60 cycles.

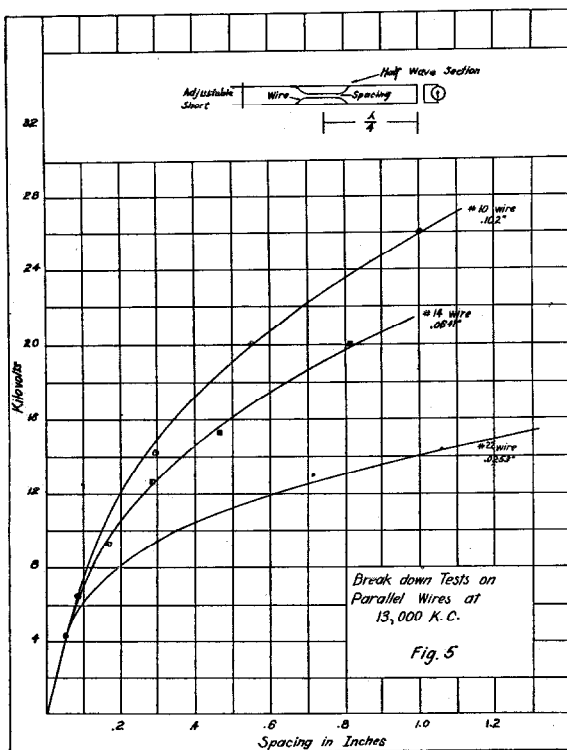

Fig. 5—Breakdown tests on parallel wires at 13 000 kc.

toward the fixed short in order that the section may be resonated. The distance through which this short is moved is a very accurate measure of the capacity of the sample, and may be used for ascertaining the capacity of the latter. See Appendix B.

In order to visualize the more fundamental features of the high frequency high voltage phenomena involved, the following arrangements well known to the sixty-cycle technique were investigated.

NEEDLE GAPS

In the case of needle gaps the action at 13 000 kc is quite different from that at 60 cycles. Fig. 4 shows a curve of the very faintest sign of corona glow with points at 60 cycles in a dark room. On the same sheet are also plotted

the voltages at which breakdown occurs at 13 000 kc. In the latter case there is no sign of corona before brilliant white spots, or what may be more descriptively named points fire, suddenly develop at the sharp tips as soon as the gradually rising voltage reaches a certain critical value. Considerable energy is immediately dissipated at the points, as indicated by the fact that tips are dulled each time a breakdown occurs and also by the fact that the section current drops immediately, showing that a loss or resistance has been introduced into the section. Due to the melting of the points, they can be used only once, after which they have to be sanded; and even then, with the most careful precautions, the results are far from being exactly reproducible, as shown by the dispersion of points.

WIRE CAPS OR PARALLEL WIRES

Fig. 5 shows the breakdown voltages between wires of various sizes at close spacings in a configuration as shown at the top of the curve sheet. Here again no corona is seen and also no agreement is found between the shape of these curves representing arcing voltage at 13 000 kc and the 60-cycle spark-over voltage as shown in Figs. 50, 51 and 93 in Peek, Jr.'s *Dielectric Phenomena in High Voltage Engineer-*

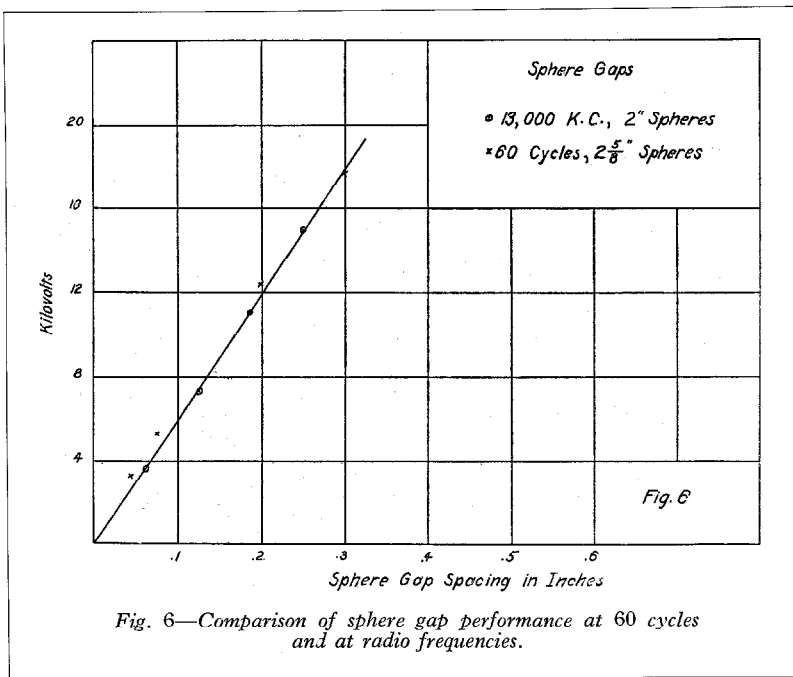

Fig. 6—Comparison of sphere gap performance at 60 cycles and at radio frequencies.

ing. However, it is of considerable interest to note that the shape of the 60-cycle corona curves in the same figures is somewhat similar to the curves of Fig. 5.

SPHERE GAPS

Fig. 6 shows a curve taken with two inch spheres set at various spacings. Here for the first time the agreement between 60 cycle spark-over data and 13 000 kc arc-over data is surprisingly good, showing that sphere gaps hold as standards for high voltage measurements at least up to 13 000 kc when the spacing between the spheres is considerably less than their diameter. As previously there is no sign of corona. In addition the results are surprisingly reproducible.

At 60 cycles, in the case of sphere gaps, when the spacing between the spheres is considerably less than their diameter, there is also no corona visible before spark-over. It is to be noted that the maximum gradient that exists between spheres under these conditions is almost uniform, and thus, when a disruptive gradient is reached, the whole region of maximum stress is simultaneously broken down, producing the spark-over. In the case of points and parallel wires at 60 cycles, the maximum gradient is not uniform at spacings larger than the diameter of the wire, but does reach a disruptive value producing corona near the conductors if the applied voltage is sufficiently high. At 13 000 kc such an enormous loss apparently occurs as soon as a disruptive gradient is reached that the ionization is not partial, causing corona as at 60 cycles, but is instead complete, causing an arc.

This view is further borne out if we consider what Peek, Jr. describes as "Disruptive Critical

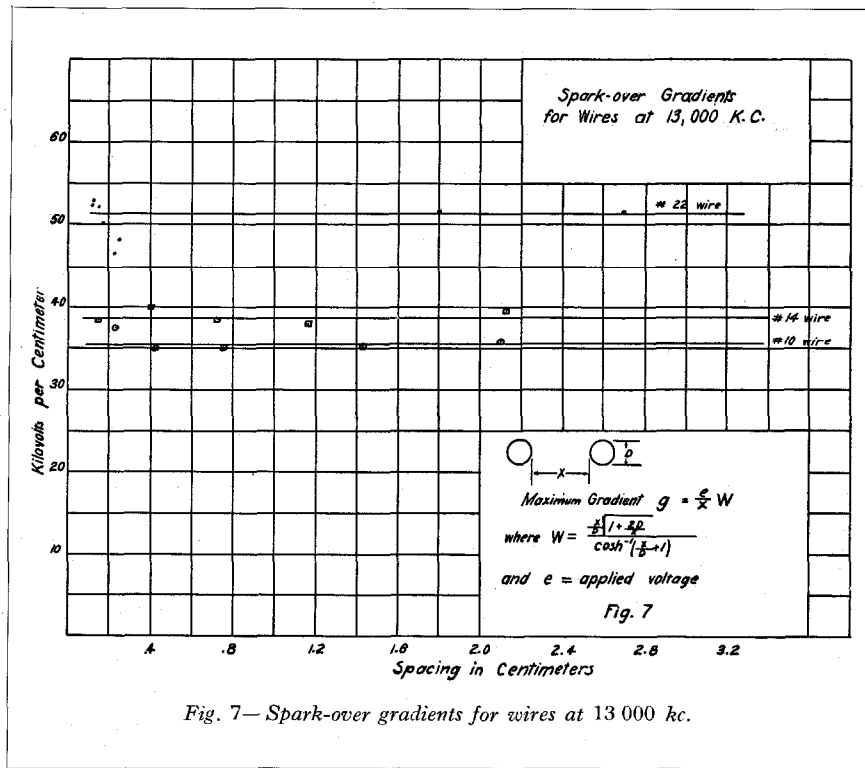

Fig. 7— Spark-over gradients for wires at 13 000 kc.

Voltage" and "Disruptive Critical Gradient" on page 188 of the previous citation. Here he shows that corona loss occurs below the voltage which produces visual corona, the voltage and gradient at which corona loss begins being named respectively, "Disruptive Critical Voltage" and "Disruptive Critical Gradient." If the gradients corresponding to voltage applied from the exact equation for maximum gradient and are plotted as shown in Fig. 7, a fairly good agreement is found to exist between the 13 000 kc breakdown gradients and the 60-cycle "Disruptive Gradient" values calculated from Peek, Jr.'s empirical formula for this gradient shown on Table III. Thus again we see that, apparently, as soon as a voltage is reached which would produce a corona loss at 60 cycles, an arc is produced at 13 megacycles.

The "Disruptive Critical Gradient" theory can also be used to explain the action of needle gaps at 13 megacycles. Apparently as soon as the magnitude of the 13-megacycle voltage is equal to the 60-cycle voltage which would cause the first bit of corona loss, the loss at 13 megacycles is so large that points fire is produced,

from which it follows that the curve for points fire shown in Fig. 4 should be below the curve for visible corona at 60 cycles, and this is the case.

It is of interest to note the ratio between the 60 cycle voltage which causes the first signs of visible corona and the 13 000 kc breakdown voltage for needle gaps. In Table I are given the ratios of the ordinates of the two curves in Fig. 4. In Table II, for comparison with Table I, are tabulated the ratios of 13 000 kc breakdown gradients and 60 cycle visual corona gradients for parallel wires. The 13 000 kc values were obtained from Fig. 7, while the 60-cycle gradients were computed from the empirical equations given by Peek, Jr. in *Dielectric Phenomena in High Voltage Engineering*.

In Table III are compared the arc-over gradients for parallel wires at 13 000 kc and the calculated "Disruptive Critical Gradient," as obtained from the empirical formula which was taken from page 192 of the previous citation. This tabulation shows the most striking correlation between 60-cycle and 13 000 kc high voltage phenomena because it seems to show that disruptive gradients are almost independent of frequency. It has been pointed out above that there is apparently no mild dielectric breakdown at 13 000 kc preceding arc-over. Furthermore, since losses are probably proportional to the second power of the frequency, it seems likely that corona cannot exist at such frequencies as 13 000 kc, but that complete breakdown of the region must take place as soon as the disruptive gradient is reached.

VARIABLE AIR CONDENSER VOLTAGE RATINGS

In the light of the fundamental facts presented above, it is now possible to begin to understand the high voltage high frequency performance of many of the various pieces of equipment presently in use in modern high powered radio transmitters, and further, since it is possible to give a reasonably correct diagnosis of the faults of the apparatus, it follows that a basis for a more correct design has also been established.

Variable air condensers in high power transmitters are one of the pieces of equipment

which are subjected to rather high radio frequency voltages, seldom much over 6 000 volts, but nevertheless sufficiently high to produce annoying and troublesome arc-overs at frequent intervals. Whenever such difficulties developed, the usual practice seems to have been to analyze the trouble in the light of 60-cycle phenomena. For example, it seems to be quite common for manufacturers to list the voltage ratings of variable air condensers as straight line functions of the plate spacings, both at 60 cycles and at high radio frequencies. The radio frequency ratings given are somewhat lower than the 60-cycle ratings. In addition, plate thickness is given some consideration, statements usually being made to the effect that thin plates reduce the maximum voltage ratings by a small amount. It is also sometimes mentioned that the plate shape at the edges has a somewhat marked effect on the rating, square edges tending to produce a lower spark-over voltage.

The 60-cycle ratings are usually correct. Even though the corona which develops during tests is not a straight line function of voltage, the spark-over voltages vary almost linearly with spacing practically regardless of plate thickness or edge shape. The above data have shown that sphere gap spark-over voltages agree almost to the point of coincidence, regardless of frequency, up to 13 megacycles as shown in Fig. 6. Fig. 4, the curve for 60-cycle corona glow and 13-megacycle points fire, tells an entirely different story. Herein lies the crux of the situation. The 13-megacycle points fire curve is not at all linear with voltage, but is quite similar to the 60-cycle visible corona curve for points, and, in addition, as Table I shows, is only about 60 per cent. of the corona glow voltage for points.

Naturally, during the life of most condensers, even though some attempt has been made in the better class of equipment to round off plate edges at least to a small degree, arc-overs occur, leaving small rough spots similar to points. This being the case, a condenser in service is comprised of smooth plates with varying numbers of little rough spots due to arc-overs on the plate edges. Under these conditions, it is only reasonable to expect that the high radio frequency voltage rating of such a piece of equipment might be similar to the voltage

rating of needle gaps at the same spacing and at the same frequency. When the condensers are new, and reasonably smooth surfaces prevail throughout, it is possible that the voltage rating might follow along the lines of parallel wires which have diameters equal to plate thicknesses, since the present common designs simulate a mesh of parallel wires at the plate edges, especially when the plates are in the position of maximum capacity.

Fig. 8 gives a rather complete picture of the performance of a number of commercial condensers after they had been in service for a considerable period of time. Here it is seen that the 60-cycle rating is linear with spacing, as claimed by the manufacturers, and that voltages well over what might be expected in the highest powered transmitters can be applied across the condenser terminals if the frequency of the voltage is in the 60-cycle region. The 13-megacycle high voltage tests show an entirely different relation between spark-over voltage and plate spacing, the spark-over voltages being much lower than the 60-cycle spark-over ratings, thus explaining the unsatisfactory operation of many supposedly well-designed condensers.

As is well known to the 60-cycle technique, and as has been pointed out above for 13 megacycles, needle gaps are rather unsatisfactory for voltage measurement compared with sphere gaps, since the spark-over voltages are not exactly reproducible, but are more or less dependent on the laws of probability. Since it was pointed out

that the condensers under test were spotted with arc-over marks, it follows that their voltage ratings both at 60 cycles and 13 megacycles should depend to a certain extent on probability, as do needle gaps; hence an exact rating cannot be given, the wide dispersion of points defining regions of limits within which spark-overs will probably occur at various spacings. It is further to be noted on Fig. 8 that the condensers tested apparently presented shapes more similar to points than to parallel wires since it is seen that the arc-over voltages for parallel wires having diameters about equal to the plate thicknesses

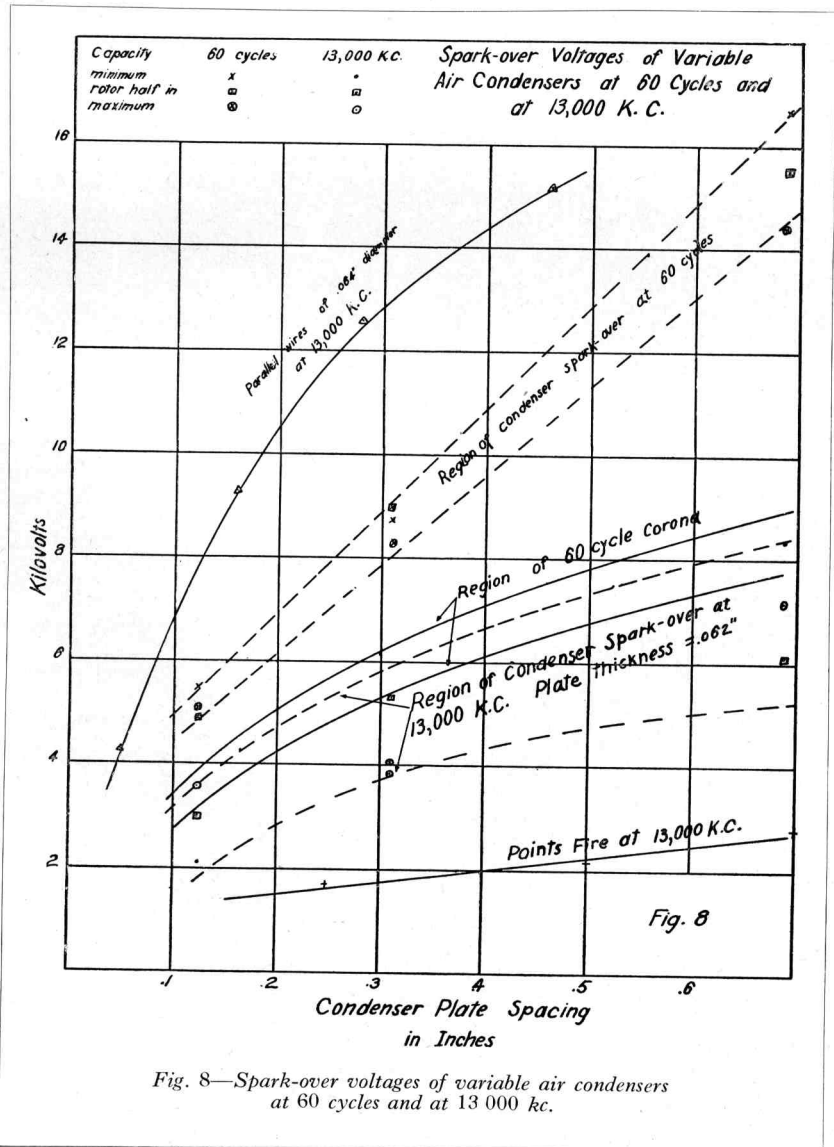

Fig. 8—Spark-over voltages of variable air condensers at 60 cycles and at 13 000 kc.

of the condensers tested were considerably higher.

At present, and at least until further investigation proves otherwise, it seems possible that the high radio frequency voltage ratings of a variable air condenser might be obtained from 60-cycle tests. Previously the 60-cycle spark-over ratings have apparently proved to be much in error at high radio frequencies, so an entirely different method will have to be used if the same errors are to be avoided. Tables I and II show that the points fire voltages and the arc-over voltages for needle gaps and wires are about 60 per cent. of the 60-cycle visual corona voltages for the same test specimens. Fig. 8 has shown that variable air condensers having a given spacing between plates have ratings in the region between such test specimens as needle points and parallel wires, so it is reasonable to believe that a similar fraction of the 60-cycle corona voltage might be taken as the maximum radio frequency rating of a condenser. Fig. 8 also shows a region for the first signs of 60-cycle visual corona on the group of condensers used in the tests. However, probably due to the irreproducibility of such things as corona glow and needle gap spark-over voltages, the 13-megacycle spark-over voltages are seen to be a little more than 60 per cent. of the corona glow voltages. Where corona first appears on the plates at 60 cycles is not necessarily the point where the 13-megacycle spark-over will occur; nevertheless, the points of 60-cycle and 13-megacycle spark-overs usually coincide, thus substantiating at least a part of the older test methods.

The insulating material used to separate one set of plates from the other in a variable air condenser provides one point of difference between an exact similarity of condensers to needle gaps and parallel wires, and therein lies a possible source of error to be carefully avoided. At 60 cycles, corona usually develops at the point of contact of the metal plates with this insulating material, the voltage at which this occurs usually having little bearing on the radio frequency voltage rating. The corona to be observed to obtain the radio frequency voltage rating is that from the edges of the plates into air.

In the above discussion and presentation of

curves it has been pointed out that the radio frequency voltage ratings for sphere gaps and needle points at the same spacing are quite different, the latter being very much lower; the difference being due to the field configurations produced by each set of electrodes. In the case of spheres, when the spacing between them is small compared to their diameters, the maximum field or gradient has been shown to be almost uniform, requiring a high voltage with respect to sphere separation to bring the region of maximum stress to the breakdown value. In the case of needle gaps there is no region of uniform stress at reasonable spacings, hence high breakdown gradients are produced at low voltages. It is clear that the radius of curvature of the sphere has all to do with the production of the desired uniform field; hence it is evident that the ultimate goal in condenser design is the production of uniform fields at regions of maximum stress, which simply means maximum radii of curvature of plate edges rather than increased spacings.

Fig. 8 shows that a large improvement could have been made in the condensers under test if all gradients had been kept as good as that between wires having diameters equal to plate thicknesses. However, it is requisite to use radii of curvatures on the plate edges which are at least one order of magnitude higher than the dimensions of the spots produced by arc-overs, with the hope that the comparatively gradually curving surfaces will partially shield the rough spots produced. The reproducibility of sphere gap spark-over voltages after repeated spark-overs has proved the validity of such a shielding effect. Not only do the plate edges need larger radii of curvature to reduce high gradients, but also all parts of the apparatus including such things as framework which are at a high potential with respect to ground or with respect to any object in the near vicinity, if the ultimate in performance is to be achieved.

INSULATOR TESTS

It seems to be common practice at present, when manufacturing stand off and strain insulators, to make an abrupt joint between the metal collars and the insulating material as shown in Fig. 9. If 60-cycle voltages were applied across such insulators, the spark-over

voltages would increase almost in proportion to the length of the insulating material. At high radio frequency this is not at all the case, and, in fact, the length has only a small bearing on the matter, the actual rating of the insulator being dependent on such things as the radius of curvature of the cap at the place where it meets the insulating material. As a rule, with insulators of this construction, the material of which the insulator is made is many times better than it need be because it is not the material but the air which breaks down. The damage which occurs is usually not due to the failure of the material under stress, but merely due to local heat produced by the arc which starts from one of the caps. In order to develop the full strength of the insulating material in practice as well as in test, it is necessary to provide the insulator with some sort of corona shields very familiar to the 60-cycle practice, but at high radio frequencies these corona shields have to be considerably better than they need be at 60 cycles. What is necessary at these frequencies is a corona shield which at 60 cycles would produce spark-over before corona, that is, an almost uniform gradient. Anything short of that results in lower R.F. spark-over than at 60 cycles. This point is difficult to over emphasize. If, for the sake of illustration, we assume an insulator has been provided with shields,

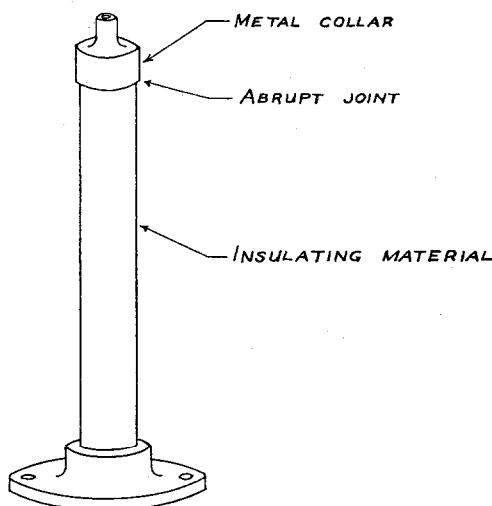

Fig. 9—Radio frequency pedestal insulator.

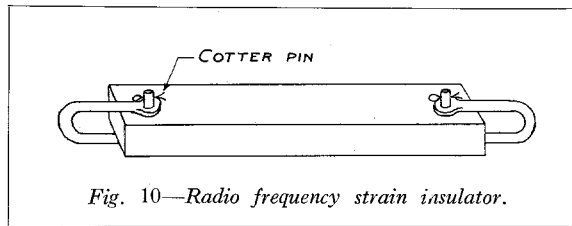

Fig. 10—Radio frequency strain insulator.

and that during a 60-cycle test there developed corona at a sharp point along the wires leading to the insulator, perhaps three feet away from opposite terminals, it is safe to predict that at high radio frequencies a breakdown will take place at the previous corona point, and this may happen in spite of the fact that the spacing between the corona shields may be only one half-inch. In order to emphasize this point still further, it might be well to point out the effect of a sharp point in some apparatus of a common type. Quite frequently rectangular strain insulators similar to the one shown in Fig. 10 are used as part of antenna equipment. These insulators have shackles and pins as fastening members, the pins being provided with cotter pins to ensure the permanency of the arrangement. When used in the normal way, the voltage rating at 13 megacycles is only about 18 000 volts because the sharp points of the cotter pins produce arcs into space. If the cotter pins are removed the voltage can be increased to over 40 000 volts, and still nothing happens.

In testing insulators it is well to keep in mind that so-called insulator failures occur for two entirely different reasons: (1) breakdown of the air around the metal fittings where the metal comes in contact with the insulating material; (2) breakdown of the insulating material itself. Most of the insulators in use at the present time fail for the first reason. Only a few equipped with carefully designed corona shields or means for distributing the gradient equally over the length of the insulator, break down for the second reason. The only exception to the latter case consists of insulators of the stand-off type which are provided with metal screws that go a long way into the insulating material, thus producing an enormous concentration of flux in the material.

Insulating materials such as synthetic resins prove to be unsatisfactory at high radio fre-

quency high voltages. When 1 000 or 2 000 volts at 13 megacycles are applied across a strip of such material about two inches long, charring streamers start over the surface of the specimen, accompanied by considerable smoke, and, as soon as the streamers from opposite sides meet, a short is produced and the test is over.

CONCLUSION

The results of the above measurements seem to indicate rather definitely that there exists a striking correlation between high voltage phenomena at high radio frequencies and at 60 cycles. The 60-cycle phenomenon which parallels the high frequency breakdown most closely seems to be the 60-cycle corona. The gradients at which high frequency breakdowns occur, appear to follow the same laws which are followed by the 60-cycle corona. The values of the gradients at which high frequency breakdown takes place appear to be systematically equal to about 60 per cent. of the gradients at which the 60-cycle visual corona begins and, moreover, appear to be equal at least approximately, to the 60-cycle so-called "Disruptive Gradient," that is those gradients at which corona losses begin to occur at 60 cycles. Our measurements are too meagre to establish the extent and the degree of this correspondence between the 60-cycle disruptive gradient and the high frequency breakdown gradients. These measurements, however, appear to be sufficiently consistent and appear to cover a sufficient variety of electrode configurations to make it seem very probable that such a one-to-one correspondence does exist. If this is the case, and we believe it is, it is not unreasonable to suppose that, in the not too distant future, it will be possible to derive useful 60-cycle information from high frequency measurements. It is only a matter of minutes to determine the breakdown voltage, and hence, the breakdown gradient between two wires or cables at a high radio frequency. If this breakdown gradient so determined is also the disruptive gradient at 60 cycles and will vary with temperature, humidity, smoke, dust and other conditions in exactly the same way that the 60-cycle disruptive gradient does, then it would be possible, with a relatively simple high frequency set-up, to find out what a proposed 60-cycle arrangement will do under given

conditions. If the 60-cycle disruptive gradient is really equal to the high frequency breakdown gradient, it is difficult to see why the two gradients would behave differently under varied conditions.

In conclusion, it should be added that our experiments were made with frequencies all lying in a relatively narrow band around 13 000 kc. Somewhere below this band there lies a transition region in which corona ceases to exist. Our experiments were made primarily for the purpose of answering certain concrete questions in regard to a particular insulation problem, and proper facilities were not readily available for extending this investigation into other frequency regions to make it more inclusive.

APPENDIX A

Upon the first impression it might be thought that the shortometer, the much-used current measuring instrument in all of these tests, would not be independent of frequency, but such is not the case, as has been found by experience and may be easily proved as follows:—

The current I , in the shortometer, as shown in Fig. 3, is dependent upon the voltage, E , induced in the loop of the instrument and inversely proportional to the reactance, ωL , of the loop. At the high radio frequencies at which the instrument is used, the impedance is of a higher order of magnitude than the resistance; hence the latter may be neglected. The voltage induced in the instrument loop is equal to the product of the mutual impedance between the loop and the short, times the current, i_s , in

the short.
$$I = \frac{\omega M i_s}{\omega L} = \frac{M i_s}{L}$$

to $2 \pi f$, and M is the mutual inductance between the shortometer and the short. Thus, it would seem that the shortometer current is independent of frequency so long as the above quantities predominate.

The accuracy of this whole method is seen to depend entirely upon how accurately the currents involved can be measured. At such high frequencies there is always considerable doubt as to the accuracy of the ammeters used, and, in fact, many of the instrument companies furnish a correction chart for their instruments

when used at frequencies above one megacycle. In view of this fact, a calorimetric method was used to standardize two clamp-on meters as shown in Fig. 11.

The theory of the standardization is as follows:—

The line from the transmitter to the dissipating resistor immersed in the water was very carefully balanced so that all of the energy on the line was series current, which simply means that the ammeters would read the same regardless of the side of the line on which they were placed. This eliminated any possibility of using the transmission line as a single conductor and the resistor as a capacitive by-pass to the line image in the ground. The resistor did not match the surge impedance of the line; hence, a building out section was installed in order to make possible a good balance on the line at the transmitter.

The conversion of electrical energy into heat at a known rate in the calorimeter is an accurate and fundamental measure of the power being transmitted by the line. The product of the readings of the clamp-on meters, spaced one quarter-wave apart, when multiplied by the surge impedance of the line, is a measure of power also, and this quantity equated to the power delivered to the calorimeter gives a standardization of the meters.

In this particular case the calorimeter and its contents had a heat capacity of 12 700 calories per degree centigrade as measured by weighing the various constituents which absorbed heat, and also taking into account their specific heats. The temperature rise as noted over a ten minute period by a very accurate thermometer was 19° C. or 1.9° C. in one minute. This gave a value of $\frac{1.9 \times 12\,700}{60} = 403$ calories per second which is equal to 1690 watts when multiplied by 4.185, the conversion factor for heat into work. The line ammeters read 0.77 and 1.00, hence $600 \times 0.77 K \times 1.00 K = 1\,690$
 $K = 1.915$

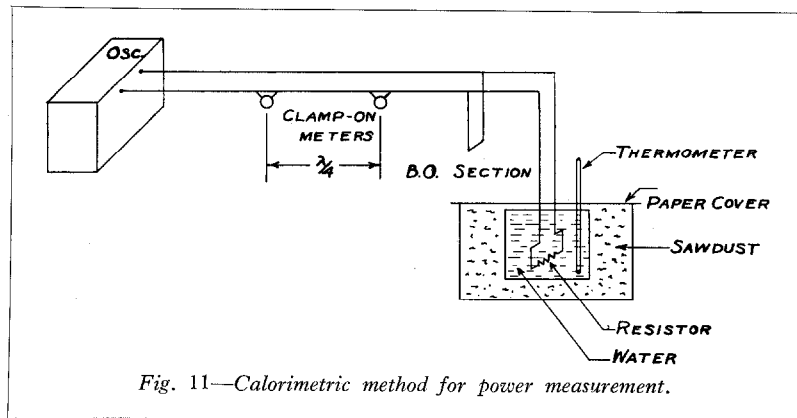

Fig. 11—Calorimetric method for power measurement.

where K is the multiplying factor for the meter in order to convert its readings into amperes.

When the standardized ammeter and the shortometer are put on a short at the same time, and current is caused to flow in the section, the reading of the shortometer may be adjusted to any desired value simply by moving the instrument up or down the staff after loosening the clamping screw. In this way positions of the instrument on the staff may be marked so that the dial of the shortometer will read directly in amperes as shown by the clamp-on meter, taking its correction factor, K , into consideration. From the above shortometer equation it is seen that if the mutual inductance, M , between the shortometer coil and the short is decreased, the shortometer current, I , will be proportionately less for the same short current, i_s . Seeing that short currents in the order of 100 amperes or more have to be measured, the shortometer can be given a convenient multiplying factor by decreasing M , which simply means moving the instrument down its staff.

When dealing with currents too large to be measured by the clamp-on meters at hand, the shortometer may be further calibrated against itself. For instance, the section current may be adjusted to near full scale reading for the shortometer by adjusting the transmitter output. At this time the shortometer may be moved down its staff until the original reading is cut in half or any other desired value, thus giving a multiplying factor of two or the inverse of that to which the reading was reduced. In order to make sure that the shortometer reading change is due only to the movement of the instrument on its staff, a meter may be clamped

on the transmission line which usually carries a very small current compared to the section short. By means of this meter and a remote control on the transmitter, the power on the transmission line may be kept constant during the shortometer calibration.

The shortometer may be similarly calibrated to read line currents by comparing it with a standardized ammeter clamped on to the line. Seeing that the field configuration in this latter case is different from that around a short, the calibrations for measuring short current will be different from those for line currents. Also, since field configuration and dimensions determine the mutual inductance, M , between the shortometer coil and the circuit in question, the shortometer must always be used in the position in which it was calibrated and in conjunction with a short of the same length as the calibrating short. In other words, the shortometer staff must be provided with a calibration for each field configuration in which the instrument is going to be used.

APPENDIX B

When any piece of equipment is put across the mid point of a half wave section, the capacity which it introduces at that point detunes the section so that it is no longer resonant to the frequency on the transmission lines. The section can again be made resonant by moving the adjustable short from the point of original and fundamental section resonant point such as R' in Fig. 12 to a new location, R . From the length of line RR' the exact capacity of the test specimen can be obtained in the following way: It can be assumed that the capacitive reactance of the test specimen was equal to the capacitive

reactance of a short section of open line at the centre of the coupled section. Instead of cutting this equivalent length out of the centre of the half-wave section, in order to decrease the capacity to the original value and thus restore resonance, it is much more convenient to move the adjustable short to the new position, R , the distance RR' being equal to the length of section which had to be cut from the centre point.

The reactance of an open section is equal to $z = -jz_0 \cot 360^\circ \frac{RR'}{\lambda}$ or $\frac{1}{\omega C} = z_0 \cot 360^\circ \frac{RR'}{\lambda}$ when only absolute magnitudes are considered, and which further reduces to

$$C = \frac{1}{z_0 2\pi f \cot 360^\circ \frac{RR'}{\lambda}}$$

APPENDIX C

Additional Precautions

During high voltage measurements it is very important to make certain that the radio frequency is not modulated. This is particularly true when the power of the transmitter is varied by remote control, and when most of the power tubes are operated below the point of saturation. In our investigations we found it very convenient to connect the vertical plates of a cathode-ray oscillograph across a few inches of the movable short of the half-wave section, while the horizontal plates were connected, as usual, to the sweep circuit. This, or an equivalent arrangement, should always be employed during such measurements to avoid possible errors which may, under some conditions, amount to some 40 per cent.

Harmonics

When a half-wave section is used in making the high voltage measurements, the second harmonic may contribute to the current but not to the voltage. The third harmonic and other odd harmonics may contribute to both. If harmonics are suspected it is

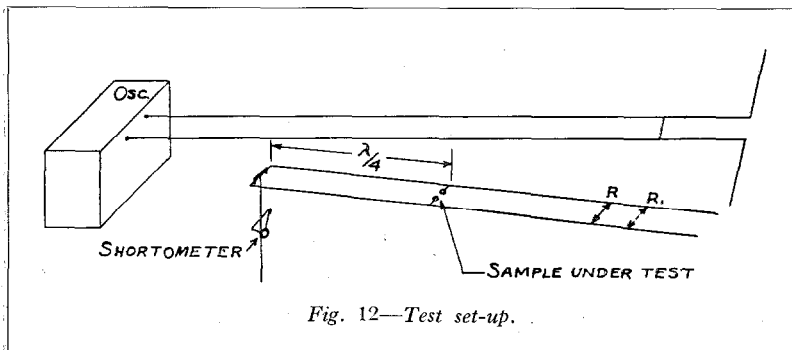

quite easy to make certain whether they are actually present. This may be done by moving the adjustable short to the half-wave positions for the various harmonics, and by measuring the current in the short with a sensitive instrument.

In our measurements the harmonic voltages were negligible, but it is quite likely that under some conditions these voltages may affect the results, and for this reason this simple check for harmonics is strongly recommended.

TABLE I

Spacing between points	13 000 kc points fire voltages taken from Fig. 4	60-cycle corona voltages from Fig. 4	Ratio
0.5"	2.1 kV	3.7 kV	0.57
1.0"	2.8 kV	5.3 kV	0.53
4.0"	4.0 kV	6.4 kV	0.62

TABLE II

Wire size	13 000 kc arc-over gradient from Fig. 7	Calculated 60-cycle visual corona gradient	Ratio
No. 22	51.3 kV/cm	g_v 80.0 kV/cm	0.64
No. 14	38.7 kV/cm	61.0 kV/cm	0.63
No. 10	35.3 kV/cm	54.7 kV/cm	0.65

$$g_v = 29.8 \left[1 + \frac{0.30}{\sqrt{\frac{D}{2}}} \right]$$

From Peek, Jr., *Dielectric Phenomena in High Voltage Engineering*, page 56.

TABLE III

Wire size	13 000 kc arc-over gradients from Fig. 7	Calculated 60-cycle "Disruptive Critical Gradient"	Ratio
No. 22	51.3 kV/cm	g_d 70.7 kV/cm	1.38
No. 41	38.7 kV/cm	41.0 kV/cm	1.06
No. 10	35.8 kV/cm	34.8 kV/cm	0.99

$$g_d = 29.8 \left[1 + \frac{0.30}{\sqrt{\frac{D}{2}}} \frac{1}{\left(1 + 230 \left(\frac{D}{2} \right)^2 \right)} \right]$$

From Peek, Jr., *Dielectric Phenomena in High Voltage Engineering*, page 192.

The Toll Board Installation, City of Rio de Janeiro, Federal District, Brazil

By W. HIRSCH,

Chief Engineer, Brazilian Telephone Company,

and

E. A. BRANDER,

Standard Electrica, S.A., Brazil

This article describes the long distance telephone plant in the central part of Brazil, owned and operated by the Brazilian Telephone Company, with special reference to the toll board in Rio de Janeiro, furnished by the Bell Telephone Manufacturing Company. The system of the Rio de Janeiro automatic network was described in the January 1938 issue of "Electrical Communication."

TOLL NETWORK

THE interurban telephone network of central Brazil, including the prosperous States of São Paulo, Minas Geraes and Rio de Janeiro, as well as the Federal District, has been expanded greatly in recent years. Simultaneously with the construction of new lines to the interior of these States, new toll boards have been installed in the cities, and transmission improved by the introduction of repeater stations.

A glance at the map (Fig. 1) gives a fair picture of the vastness of the Brazilian territory and the comparatively low telephone development, now only in its initial stage. During recent years, however, progress has been important; long-distance calls handled by the Brazilian Telephone Company increased from 3 355 000 in 1930 to 6 898 000 in 1938, and expansion of toll plant during the same period has been spectacular (Fig. 2).

North American methods have mostly been followed in the lay-out and construction of the plant. Open-wire construction with No. 12 metallic (copper) circuits predominates. In future, some cable development is expected on the heavy traffic routes, but the climatic conditions, with complete absence of snow and sleet, favour the open-wire type of plant. The newer carrier developments with 15 channels on each open-wire pair also seem to extend the usefulness of exposed lines; and, in anticipa-

tion of these new facilities, pole lines have recently been built with the narrow 8-in. spacing between wires.

The map (Fig. 1) shows the main toll centres of the system. At the end of 1938 a total of 914 distinct localities was connected. Telephone connections with the rest of the world are made exclusively over radio by mutual arrangement between two companies, one of which, the Companhia Radio Internacional do Brasil, is owned by the International Telephone and Telegraph Corporation.

Problems involving the handling of international calls are only of secondary importance in the design of the interurban network. The ramifications of the network in Brazil, however, are such that transmission and standardization problems must be most carefully considered.

The maximum distance between toll centres in Brazil is at present approximately 1 500 km; in general, current American practices have been applied. A fundamental transmission plan which ultimately aims at a maximum of 32 db. overall equivalent for any connection within the toll network has been established.

The controlling transmission factor is the toll terminal losses in the Federal District. The investment in interoffice trunks for toll switching within the City of Rio de Janeiro is raised due to the elongated shape of the city along the coast line. The situation is further complicated by the fact that the whole Federal District—of

which the City of Rio de Janeiro forms a part—is comprised in one toll centre. The Federal District covers an area of 1 167 square km. The toll terminal losses permitted to the outlying rural zones run to 14 db., whereas the city exchanges are kept below 10 db. To obtain these results, the toll switching trunks are 19-gauge, and H-135 loading is extensively used.

In order to keep the overall toll circuit losses within limits, the main routes such as Rio de Janeiro—Bello Horizonte and São Paulo—Rio de Janeiro, must be adjusted to a net equivalent of 4 db. from toll board to toll board. As cord circuit repeaters are not used—they have been removed from all but two localities—terminal repeaters are used extensively on medium haul lines. The toll network is laid out on the “pad switching” principle, although up to the present there has been no necessity for equipping pads. The wiring lay-out at toll boards has generally been made for pads.

The city of São Paulo is, commercially, the most important toll centre ; Rio de Janeiro

follows as a close second. The traffic between these two centres, approximately 500 km apart, is handled over 29 direct lines, which form the backbone of the toll network ; 14 are physical and phantom, and 15 are carrier circuits of the C-3 type. In addition, long-distance dialling facilities permit the outward operators, both in Rio de Janeiro and São Paulo, to reach directly automatic subscribers in the distant cities without assistance from inward operators.

**TOLL BOARD INSTALLATION—
FEDERAL DISTRICT**

The rapid growth of the toll network has necessitated efficient toll board operating methods and continuous expansion of the traffic handling facilities. The existing No. 1 Western Electric toll board was replaced in 1930 by a Bell Telephone Manufacturing Company No. 2003 board, similar to the Western Electric No. 3 board.

The improved switching methods of the new equipment in turn stimulated the use of the long-

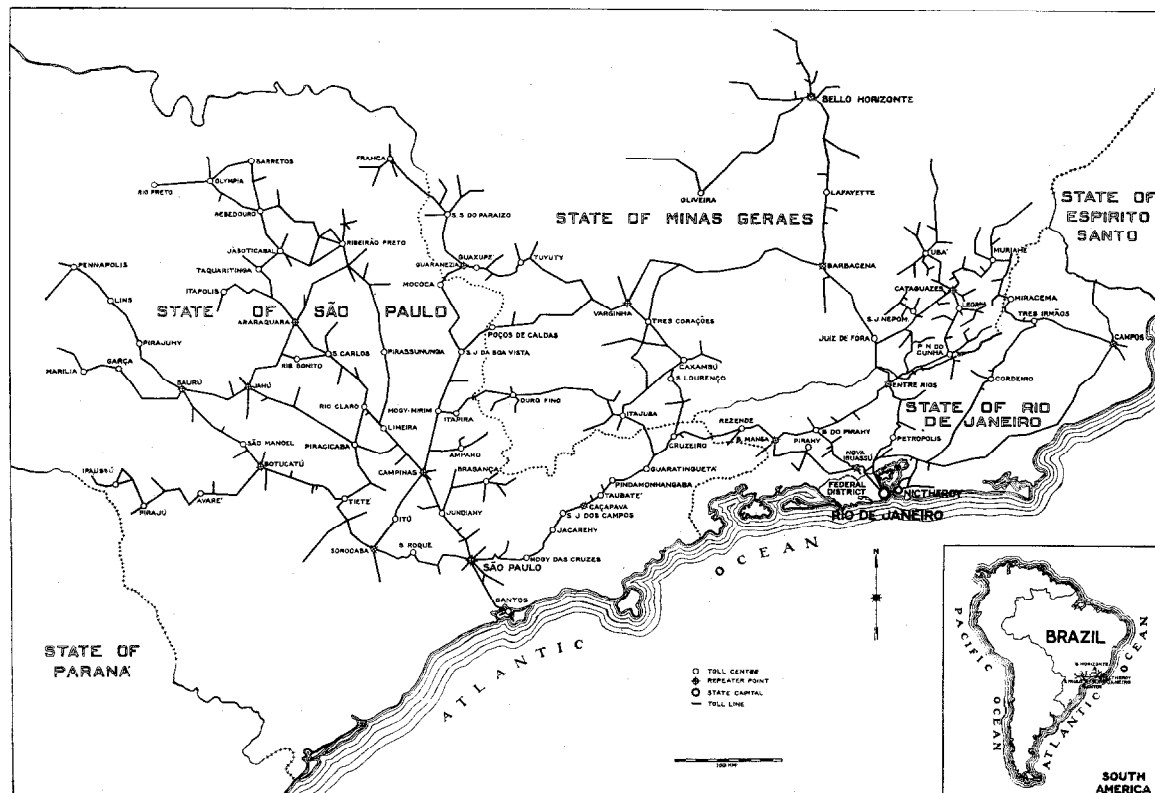

Fig. 1—Map indicating Brazilian telephone development.

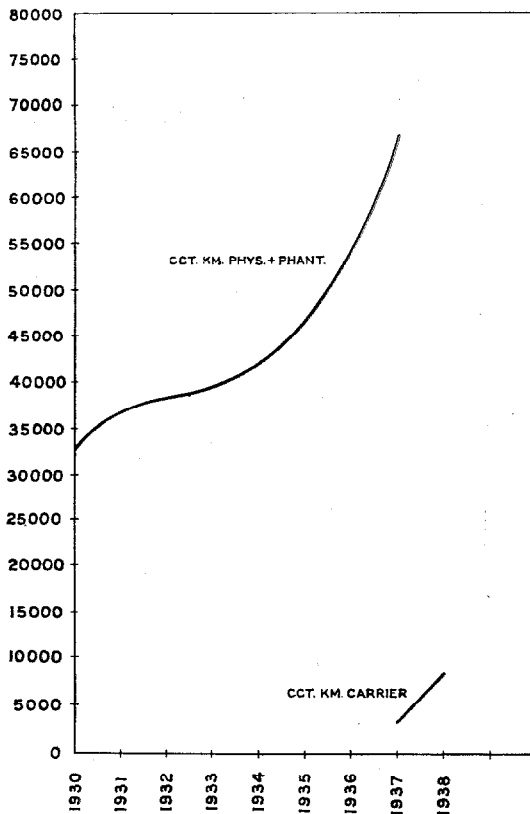

Fig. 2—Expansion of Brazilian Telephone Company toll plant.

distance service. At present, 47 per cent. of all calls in Rio de Janeiro are handled on the CLR method of operation, and 64 per cent. of all calls recorded are completed within 5 minutes. The number of calls not completed on CLR due to “no-circuit” conditions is negligible.

Toll Exchange Extensions

The 30-position No. 2003 type toll board, installed in 1930, soon proved insufficient to carry the ever-growing toll traffic, and, in 1934, it was increased from 30 to 48 positions.

As the number of subscribers and the extent of telephone service increased, the Brazilian Telephone Company found it desirable (early in 1937) either to replace the existing toll board by an entirely new cordless toll board or to extend the existing one. In order to keep the investment at a minimum consistent with good service, and in consideration of the relatively short time the existing positions had been in

service, the Company decided to:—

- (a) Add a new line-up of 32 No. 2003 positions;
- (b) Introduce a pneumatic tube distribution system;
- (c) Introduce an automatic recording distribution system;
- (d) Extend the toll switching equipment;
- (e) Extend the toll test board;
- (f) Modify existing toll and service observation positions.

The above equipment, manufactured by the Bell Telephone Manufacturing Company, Antwerp, was installed in 1938 and opened to traffic early in 1939.

Equipment Lay-out

The toll office is laid out for an ultimate of six lines of toll board, totalling 220 positions on one floor. The ground floors are occupied by the machine and battery rooms, the various distribution frames, the toll test boards, the 7-D House P.A.B.X., the recreation rooms and the kitchens. The first floor accommodates the toll board, the 50-position local information board, and the House P.A.B.X. Attendant's Board; an adjoining wing contains the toll switching rotary equipment, the 10 000-line 7-A.1 office “23,” and the 10 000-line 7-A.2 office “43.” The pneumatic system machinery, and the local as well as centralized observation boards, are located on the mezzanine floors.

The floor plan of the toll operating room and the toll switching equipment is shown in Fig. 3.

Type of Sections

The 16 additional sections are of the all-welded type; they have the same outside dimensions as the older ones, and can be aligned without difficulty.

The welding process made it possible to simplify the iron framework inasmuch as rivets, bolts and nuts have practically disappeared, the framework thereby becoming lighter and less likely to suffer distortion during shipment and installation. The new construction also gives greater accessibility to the equipment when the rear doors are removed. These doors are interchangeable, and can be slid along the whole length of a line-up of sections.

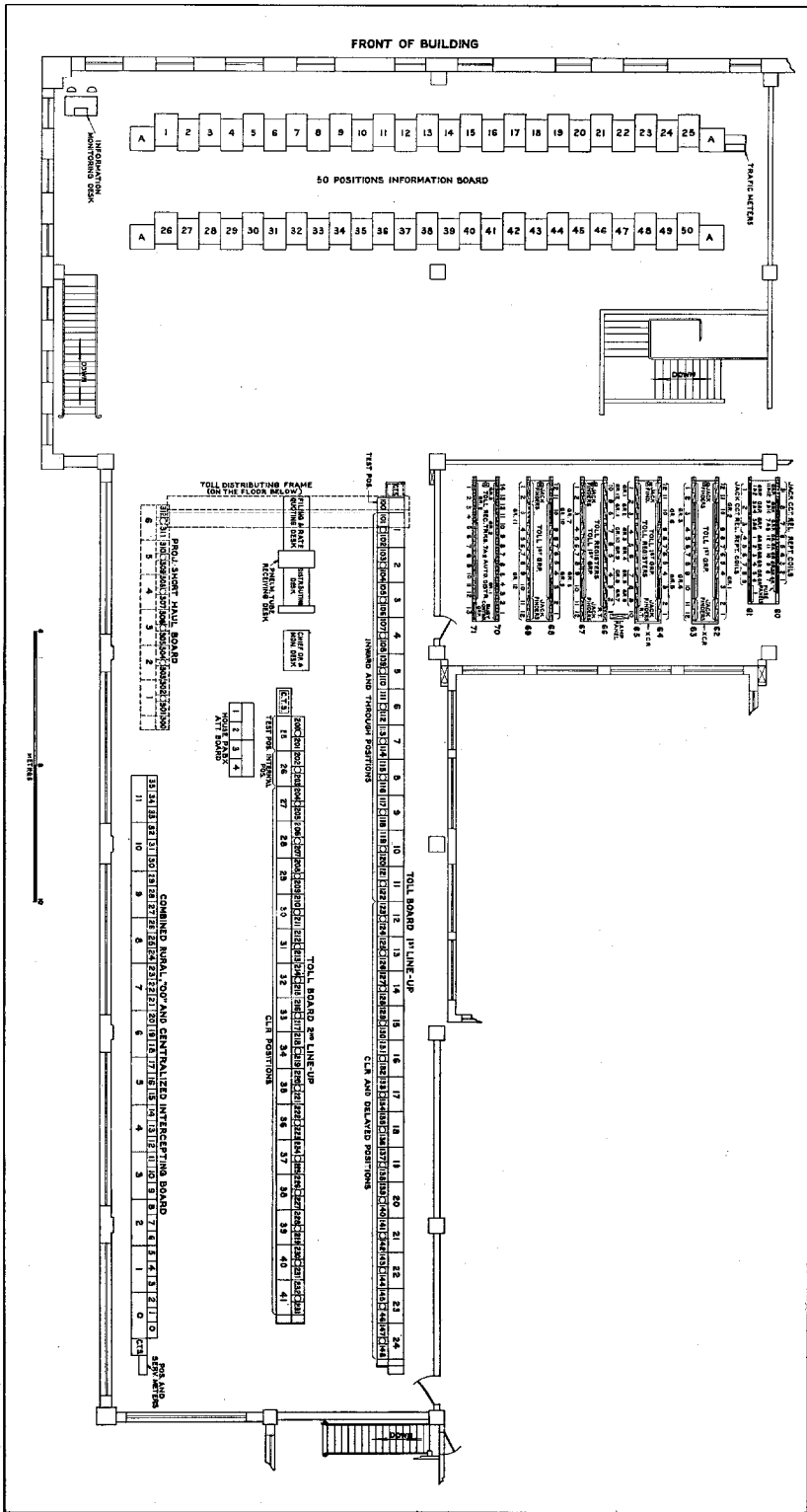

Fig. 3—Floor plan of toll operating room.

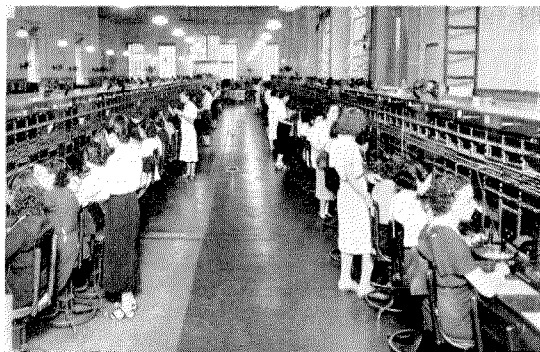

Fig. 4—"Norte" toll sections.

The complete absence of uprights in the upper rear part of the sections renders the multiple cables perfectly and equally accessible at any point of a line-up, a feature which is appreciated both by installers and maintenance men. Fire protection panels were omitted, since their usefulness is doubtful.

Fig. 4 illustrates the line-up of the toll sections.

Automatic Toll Recording Distribution System

The congestion of the recording trunk multiple, which reacted on the speed and quality of the service, made desirable the introduction of an automatic call distribution system, with individual jacks and lamps on the toll positions.

The well-known 7-A.2 type system consists of an incoming trunk relay circuit with an associated distributing finder. The jack circuits associated with the various toll positions terminate on arcs of the distributing finders, according to the group of incoming recording trunks to which the circuit belongs. The recording trunks are split into two main groups, namely, 7-A.1 and 7-A.2 offices, in order to obtain discrimination on the jack circuits of the toll positions by means of which the operator can determine at once whether a call originates from a 7-A.1 or 7-A.2 subscriber. This is necessary because the 7-A.1 trunks, older in design than the 7-A.2, do not permit re-call of the originating subscriber without disconnect. The more recent 7-A.2 system has all facilities for complete CLR service, including ring-back on recording trunks. Each of the main groups is divided into sub-groups but interconnected by means of overflow finders.

At normal hours (day-time), a recording call reaches an idle CLR position. During slack hours or at night, through the operation of a key, inward and concentration positions have access to the recording distribution system.

The recording jacks in the operator's positions are associated with a "position busy" control circuit, which is operated by the positional talking circuit, and is under the control of an extra contact on the operator's telephone jack. This positional circuit controls the testing of the jack circuit. Consequently, the recording jacks of a position are only available for incoming calls when the position is free and staffed. A staffed position is blocked: (a) when a recording call has not yet been attended to; and (b) when any talking key is off normal. The blocking condition is indicated to the traffic supervisor by two pilot lamps at the top of the positions.

If no position is available in the associated group of jack circuits at the moment a call arrives, a test potential is applied to the corresponding terminals in the distributing finder arcs, and the overflow finder belonging to the other groups of jack circuits starts hunting for a free jack in the corresponding groups. The completion and supervision of a connection over an overflow finder are performed in exactly the same manner as for a regular finder.

When all operators' positions in the various groups test busy, or all overflow finders associated with a given group of trunk circuits are engaged, an indication is given to the group busy circuit and to the waiting call circuit associated with the busy sub-group, the result being that the incoming calls then test on the corresponding terminals of the waiting call circuit and are parked in the sequence in which they arrive. When a position becomes free, a signal is given to the waiting call circuit, which causes the first waiting call finder to start hunting for this particular position. (In order to prevent the full traffic from being routed over them the overflow finders are accessible during parking periods; they are assigned exclusively to carry overflow traffic.) As soon as the jack circuit has been tested, the remaining waiting calls are advanced one step. In the event of more than one operator's position becoming free, the indication received by the waiting call circuit causes the hunting of all waiting finders in the

sequence in which they were standing on the waiting terminals. It is to be noted that, during hunting of waiting calls, all fresh incoming calls are blocked, and hunting in their case is prevented; thus, during busy hours, waiting calls have full preference over fresh incoming calls. On premature release of a parked call, all the preceding waiting finders make a step forward to occupy the position which is becoming free. Control lamps on the chief operator's position facilitate observation of the switching conditions and of the presence of traffic overloads.

Each CLR position is equipped with a 10-jack strip for recording, cabled to the TDF, where they can be cross-connected to any incoming recording circuit from a 7-A.1 or 7-A.2 exchange. In practice, only 6 jacks per position are assigned. Experience has shown

that this number may be further reduced and still provide full load for the long-distance operator.

This call distributing system serves only the regular "01" toll recording calls from 7-A.1 and 7-A.2 exchanges, whilst the direct toll subscriber service is handled on a regular multiple answering basis on the CLR positions. In addition, a dial system A-board is arranged for multiple answering for the following services:—

- Toll restricted 7-A.2 subscribers calling "07";
- Toll restricted 7-A.2 subscribers calling "01";
- Coin boxes calling "07";
- Coin boxes calling "01."

The routing of these calls for toll restricted subscribers is controlled by the registers in the automatic exchanges.

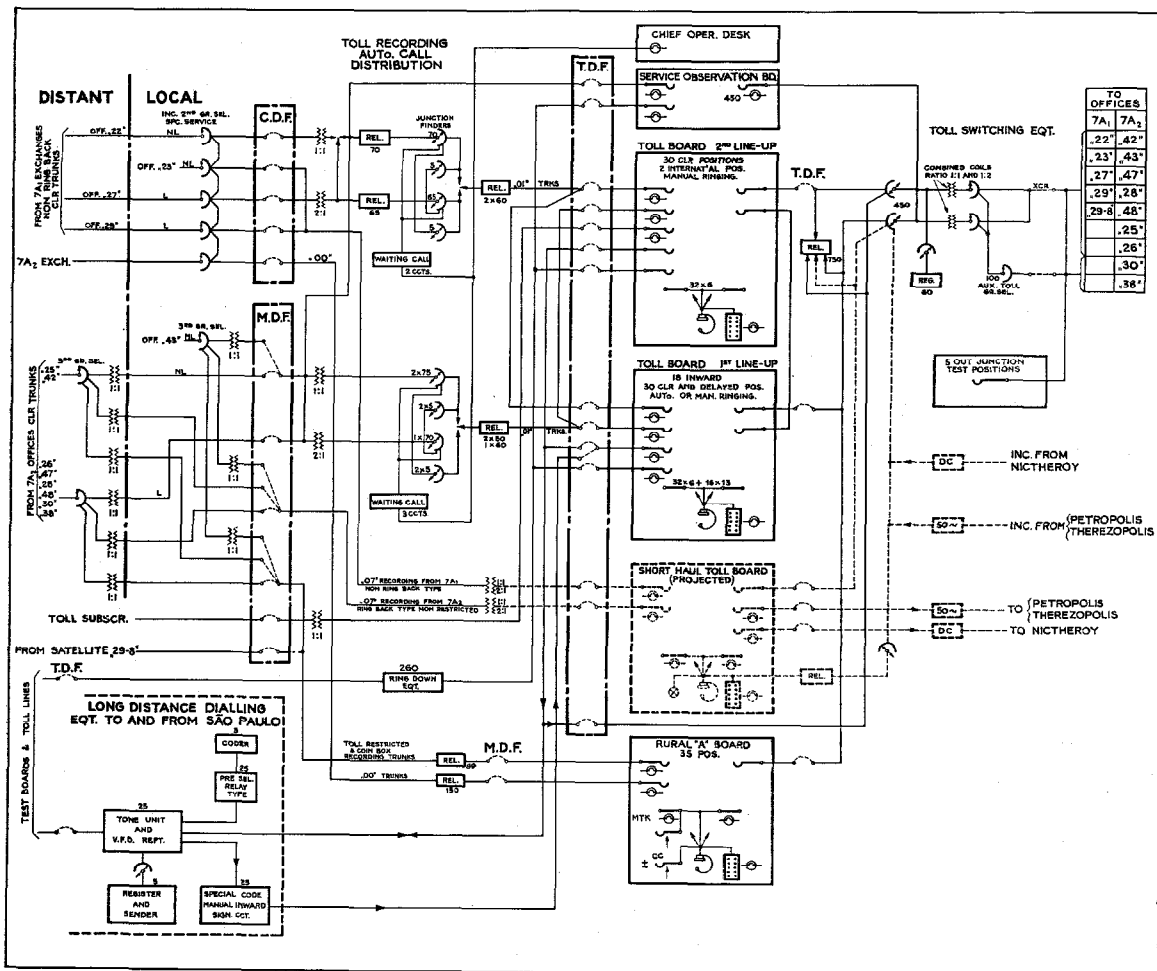

Fig. 5—Rio de Janeiro toll office junction diagram including rural service.

The skeleton junction diagram for the Rio de Janeiro toll office is shown in Fig. 5.

AUTOMATIC TOLL SWITCHING SYSTEM

Toll connections are extended towards the called subscribers of the Rio de Janeiro area by means of the automatic toll switching train, utilizing the 7-A.1 Rotary System.

To build up a connection, inward and CLR operators use a 10-button high speed key-set. Ten groups, each of 75 jack relay circuits, are connected to the arcs of 10×45 100 point jack finders, with which are associated the toll first group selectors and the toll register circuits giving the toll operator access to local or distant group selectors of the next selecting stage.

To the 7-A.1 local Exchange "23" calls are routed over local 2nd group selectors, local 3rd group selectors and the final selectors, while towards the 7-A.2 local Exchange "43" calls are directed via local 3rd group selectors, penultimate and final selectors.

Towards distant 7-A.1 and 7-A.2 offices the toll switching calls are routed, in the first case over incoming toll 2nd group selectors, 3rd group and final selectors, and in the second case, over incoming toll 3rd group selectors, penultimate and final selectors. Auxiliary toll 1st group selectors are connected to the 7th level of the regular 1st group selectors giving access to ten other 20 000 line units, two of which (offices "30" and "38") are being installed and will be opened to traffic towards the end of this year.

The toll registers, which receive the operator's key-set impulses and control the setting of the selectors to establish the toll connections, have recently been converted from 5- to 6-digit sending. During selection, an outstepping relay responds to reverive impulses from the commutator of a group or final selector. The routing of calls is independent of the numbering scheme since the digit sent by the operator's key-set and the outstepping are associated as required. Tandem trunking may, therefore, be introduced at a future stage.

A call is originated by the toll operator plugging her toll cord in an outgoing jack, which starts the hunting of all free jack finders; and, when one of the finders has picked up the calling

trunk, a number of finders, each with a register circuit attached, hunts for the toll 1st group selector. The register of the successful finder is connected through, transmitting a visual (impulse ready) signal to the toll operator. During selection, the register controls itself and the cord circuit for premature releases. If the operator should depress a non-existing prefix, the register is arranged to send back a flashing ground to the key-set lamp. She will then withdraw her plug, causing the release of the connection.

7-A.1 final selectors and 7-A.2 penultimate group selectors are arranged either for automatic or manual ringing; the 7-A.1 toll group selector, however, has not been designed to discriminate between these two methods and, since the toll 1st group selectors are common to all operators, whether inward or outward, manual ringing is applied to toll switching calls. With the introduction of long-distance dialling, the manual ringing method results in considerable delay in establishing a connection and, therefore, the possibilities of introducing automatic ringing on certain calls and suppressing it on others were studied, as indicated below.

The toll 1st group selectors and toll switching jacks will be divided into two sub-groups to provide means either for automatic or manual ringing on the toll boards, where separate positions exist for inward and outward service. Incoming calls originated at distant areas are handled on inward toll positions. The distant operator controls the connection and the inward operator only extends the call, by means of her key-set, from the toll line to the local subscriber. It is, therefore, time-saving to ring the subscriber automatically and without any waiting time.

On the outward positions, which deal with calls originated by subscribers in the Federal District, the operator, in case of delay, must be able to set up a connection to the calling subscriber without ringing the subscriber immediately, as this must happen only at the moment the toll connection is completed. Therefore, inward operators will have at their disposal jacks providing automatic ringing, and outward operators will have jacks suppressing automatic ringing.

Incoming LDD lines will be connected

straight to toll switching groups providing automatic ringing.

It is to be noted that 7-A.2 toll group selectors are designed either for automatic or manual ringing without being split into two groups.

With the rapid development of the Rio area, another important problem arose when the loading principle was applied to the trunk cables between the automatic exchanges located in remote districts of the city, where distances reach almost 15 km, and loop resistances are as high as 800 ohms.

The problem consisted in balancing properly the impedance of loaded and non-loaded junctions with the 600-ohm toll office impedance, i.e., connecting a 1:1 ratio repeating coil between the toll office and a non-loaded junction, and a 1:2 ratio coil between the toll office and a loaded junction, in order to avoid excessive reflection losses. Furthermore, provision has been made for switching in a transmission pad at the toll line when it is terminated via a short local junction, and to cut out the pad when connection is made via a long or loaded local junction.

The solution of the problem, shortly to be applied, consists in a scheme whereby the toll 1st group selector (1) recognizes whether the connection is extended to a long or a short junction (so that it can connect the pad switching resistance accordingly), and (2) utilizes the indication to change the ratio of the repeating coil.

This discrimination can be accomplished by providing repeating coils in the toll 1st group selectors with taps on the secondary windings, and a relay which inserts either the whole or part of the secondary winding, depending on whether the call is extended to a long or a short junction. This relay will be arranged to operate from the toll register. The prefixes for the various offices, which are key-sent into the register, will make it easy to discriminate between offices having long or short junctions, and to control the operation or non-operation of the relay in the toll 1st group selector.

The above solution will also make it possible for LDD toll lines to enter on the toll 1st group selectors which provide automatic ringing and which, in addition, permit proper impedance matching depending on the direction of the call

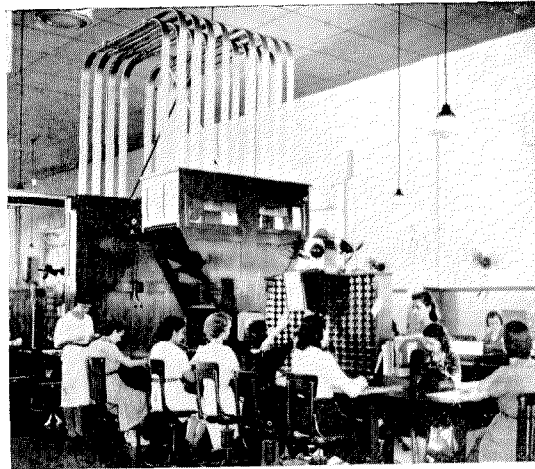

Fig. 6—Combined rate quoting, ticket filing and distributing desk.

in the local area. The toll 1st group selectors will also be split into two groups for inward and outward traffic, depending on whether or not automatic ringing should be given. The scheme is illustrated by the junction diagram of Fig. 5.

PNEUMATIC TICKET DISTRIBUTING SYSTEM

The pneumatic ticket distributing system, manufactured by the Bell Telephone Manufacturing Company, functions in principle as follows:—

- (1) Collects the finished tickets from the CLR and delay positions, as well as tickets which cannot be completed on the CLR positions, and conveys them to a receiving table. (For this purpose the tube is operated by means of the rarified air or vacuum system);
- (2) Despatches the tickets from the distributing table to the delay positions. (In this case air under pressure is used.)

The receiving and distributing tables are located adjacently in the operating room.

The essential difference between the vacuum and the pressure system is that, in the vacuum system, an open end of the tube, or a simple valve, is used to insert the ticket into the tube, the discharge of the ticket being effected through a terminal with an air flow diverting device. In the pressure system, the sending valve is constructed with an air lock.

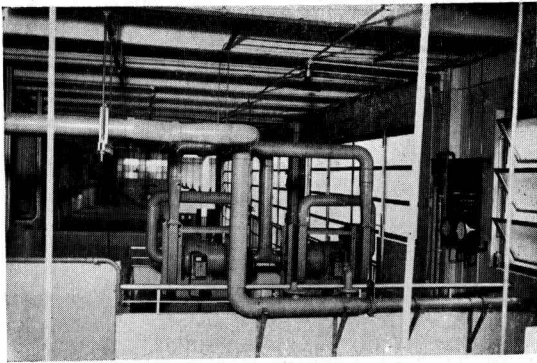

Fig. 7—Pneumatic system machinery.

The vacuum system tubes are continuously connected; the pressure tubes are only in service when a ticket is introduced. The air pressure against the tickets projects them through the tube, including bends and twists, at approximately 20 feet per second.

The application of single vacuum sending valves in all the toll positions makes possible the use of one combined ticket filing, rate quoting and distributing desk. It is illustrated in Fig. 6.

Two centrifugal fans or turbo blowers maintain a practically constant pressure or vacuum over a wide range of output. A pressure regulating valve is introduced in the main pressure tube, thus keeping the pressure in the tubes constant without affecting the machine output. This is essential, since the intermittent operation of the pressure-worked tubes would otherwise result in a wide variation of load on the blower.

The two turbo blowers operate alternatively; the individual capacity is 550 cubic metres per hour with a total static pressure between vacuum and pressure of 1 200 mm W.G. at 2 900 r.p.m.; they are directly coupled to 8 h.p. 50-cycle, 220-volt, centrifugal starting motors. Operation is silent and minimum floor space is required.

The ticket tubes are of the rectangular brass type with internal dimensions 70 mm by 10 mm. The inner surface of the tube is slightly corrugated, thus minimizing friction due to possible surface scaling.

The system includes the latest improvements and utilizes the No. 4003-A McGregor vacuum receiving valve developed in the British Post Office laboratories. To assist the proper des-

patch of tickets, the usual signals are associated with the sending tubes.

Fig. 7 shows the pneumatic machinery located on a special platform in the toll terminal room below the combined ticket receiving, filing and distributing desk.

SHORT HAUL TOLL SERVICE

Calls within the limits of the Federal District are not regarded as toll service, although they extend 50 km maximum from the toll centre. They are handled over the "Rural A-Board," which is in the same room as the toll board. Subscribers dial "00," and their calls are automatically extended to the Rural A-Board. The "A"-operator completes the calls without delay to the zones outside the city network.

For the future, a short haul toll board is planned. The automatic equipment for recording trunks has already been laid out; "07" will be dialled for short haul toll calls. This service will be adopted for nearby cities, such as Nictheroy, the Capital of the State of Rio de Janeiro, Petropolis, Therezopolis and Nova Iguassu; its operation will be simpler, more direct and speedier than the long haul service. The maximum distance planned is about 100 km; the equipment will be arranged for

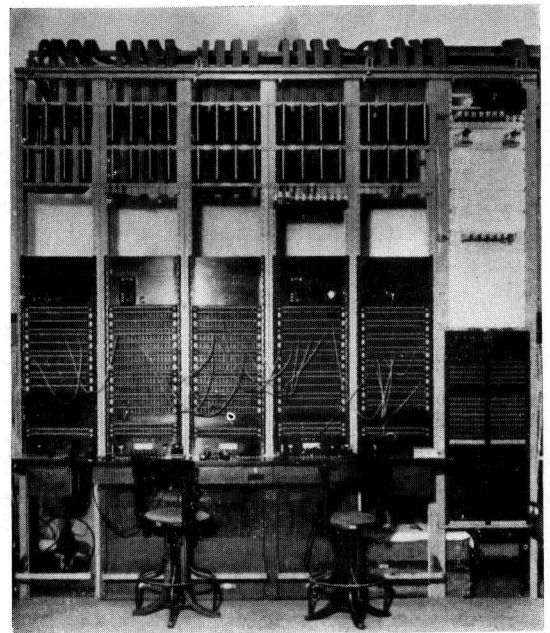

Fig. 8—Toll test board.

D.C. or 50-cycle dialling, according to the distances covered.

Toll Test Board

The toll test board consists of 5 positions and a separate panel for reporting defective lines from the toll board in the operating room. As will be noted from Fig. 8, this panel is adjacent to the test board on the right-hand side.

The test board is of the conventional type, similar to Western Electric No. 5, and is equipped with two voltmeters and one Wheatstone bridge.

The actual jack field equipment is for 300 lines. The space requirements have been reduced by the use of double spring jacks, instead of the single mounted jacks generally used where telegraph lines are superimposed on the telephone facilities. The usual 10-jack circuit per line is thus reduced to 5 jacks.

The defective line panel has a key and 2 lamps per toll line, and is wired to a similar panel on toll position No. 200. The chief operator reports a defective line by pulling the key on the toll position corresponding to this line. A lamp signal then lights on the panel near the test board and the tester immediately checks the defective line. When the trouble is cleared, he signals the fact, by means of a push-button key, to the operator on position No. 200.

Besides saving time in reporting and clearing trouble on toll lines, this arrangement marks the toll line busy in the multiple of both line-ups, from the moment of reporting the trouble until again accepted as cleared by the Traffic Department, without further attention on the part of the operator.

CALCULAGRAPHS

Toll positions are equipped with No. 30 type calculagraphs, which provide means for timing telephone calls by recording the elapsed time on paper tickets. These calculagraphs are equipped with self-starting synchronous motors operating on 20-volt, 50-cycle, alternating current.

The power supply for the synchronous motors is obtained from a commercial source of 127-volt, 50-cycle, alternating current. The mains supply is connected to one 500 VA transformer to reduce the pressure to 20 volts in view of the decreased fire hazard in 20-volt wiring and the possibility of using wiring of smaller diameter. This type of transformer can serve a maximum of 60 calculagraphs.

A Diesel emergency set has been installed to provide power for operating the calculagraphs and the toll office in general in the event of interruption of the commercial power supply.

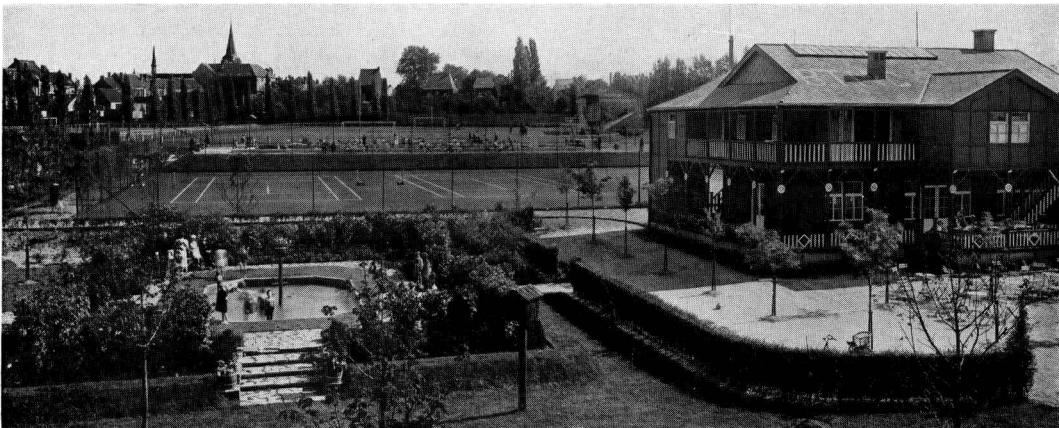

The sports and recreation grounds of the Bell Telephone Manufacturing Company, Antwerp, cover nearly 10 acres. They include a roomy club house, a playground for children with a children's swimming pool (visible in left foreground), an Olympic-size swimming pool, football grounds, basket-ball field and tennis courts.

The International Telecommunication Convention

Summary of Organization, Provisions and Operation

By Commander F. G. LORING, O.B.E., R.N. (Rtd.), M.I.E.E.,

Vice-Chairman, International Marine Radio Company Limited, London, England

1. INTRODUCTION

THE International Telecommunication Convention (see Fig. 1) is the document which was drawn up and agreed to by the members of the International Telecommunication Union at a Plenipotentiary Conference which assembled in Madrid in 1932.

The Convention is completed by Regulations which are revised as necessary by Administrative Telecommunication Conferences which are held at intervals of about five years. The last of these Administrative Conferences was held in Cairo in 1938 and the next one is scheduled for Rome in 1942.

A Telecommunication Conference is attended by:—

- (1) *Delegates*, who are persons sent by Governments.
- (2) *Representatives*, who are persons sent by private enterprises operating a public telecommunication service, and recognized by Contracting Governments.
- (3) *Observer-Experts*, who are persons sent by other radiocommunication enterprises and international organizations interested in radio communication services.

The right to vote at plenary assemblies is confined to the Delegates of Contracting Governments.

Telecommunication is defined as "Any telegraphic or telephonic communication of signs, signals, writing, facsimiles and sounds of any kind, by wire, radio or other systems, or processes of electric signalling or visual signalling (Semaphores)."

2. THE INTERNATIONAL TELECOMMUNICATION CONVENTION

The International Telecommunication Convention was drawn up by a Conference of

Plenipotentiaries of the Contracting Governments and it can only be revised by a similar Conference. It lays down the general principles governing international telecommunication, and the participating parties must accept at least one of the sets of Service Regulations which are annexed to the Convention. The Convention itself deals in particular with such questions as arbitration, language, secrecy, the monetary unit, the establishment of consultative committees, and matters pertaining to the Bureau of the International Telecommunication Union (see section 5). It also imposes the observation of certain principles relating to and peculiar to Radiocommunication, such as compulsory intercommunication in the mobile services, avoidance of interference, acceptance of Distress Calls, and questions connected with installations for National Defence.

A Conference of Plenipotentiaries only meets when specially convened.

3. THE INTERNATIONAL TELECOMMUNICATION UNION

Article 1 of the International Telecommunication Convention states that the countries which are parties to the Telecommunication Convention form the International Telecommunication Union, which replaces the Telegraph Union. Article 2 states that the Convention is completed by the following sets of Regulations:—

Telegraph Regulations
Telephone Regulations
Radiocommunication Regulations.

4. THE ADMINISTRATIVE CONFERENCES

These Regulations may be revised by "Administrative Conferences" attended by delegates of the Contracting Governments. A

THE INTERNATIONAL TELECOMMUNICATION UNION
 at a Plenipotentiary Conference (Madrid, 1932)
 drew up a document entitled
 THE INTERNATIONAL TELECOMMUNICATION CONVENTION
 which authorizes the calling, from time to time, of
 INTERNATIONAL TELECOMMUNICATION ADMINISTRATIVE
 CONFERENCES
 for the revision of the Regulations attached to the Convention

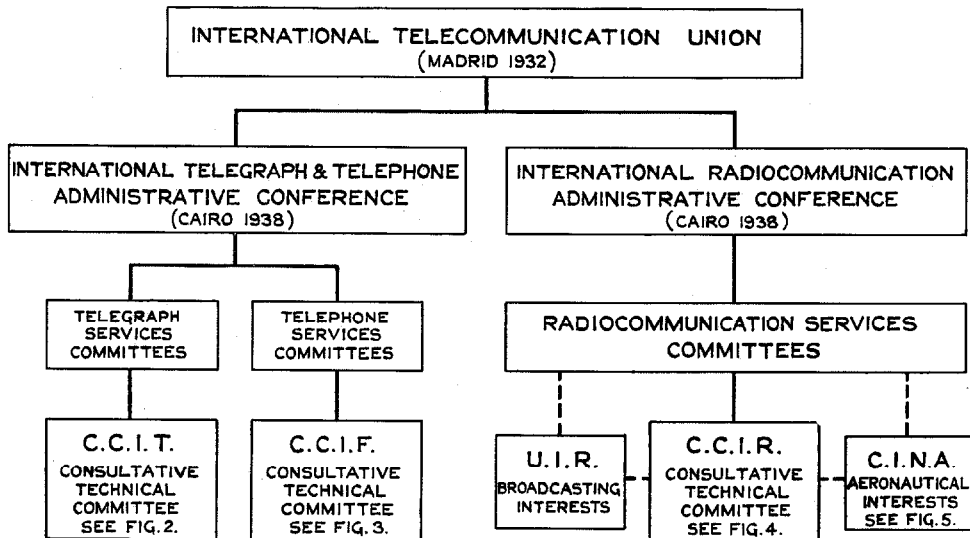

Fig. 1—General organization under the Convention.

Conference may admit the participation in a consultative capacity of Representatives and Observer-Experts, whose interests may be affected by the decisions of the Conference.

Each Conference fixes the place and date of the next meeting.

Until the Madrid Conference in 1932 the Telegraph and Radiotelegraph Conventions were separate entities, and the Telegraph and Radiotelegraph Conferences were held at different times and different places. A decision was made at the time of the Washington Radiotelegraph Conference in 1927 to merge

the Telegraph and Radiotelegraph Conventions in a single Telecommunication Convention which, as already stated, was subsequently completed at Madrid in 1932.

A Telecommunication Administrative Conference, accordingly, is composed in practice of two separate Conferences concerned with the regulations for (a) Telegraphy and Telephony and (b) Radiocommunications, respectively. The delegates and others attending the Telecommunication Conferences in many cases represent both telegraph and radiocommunication interests.

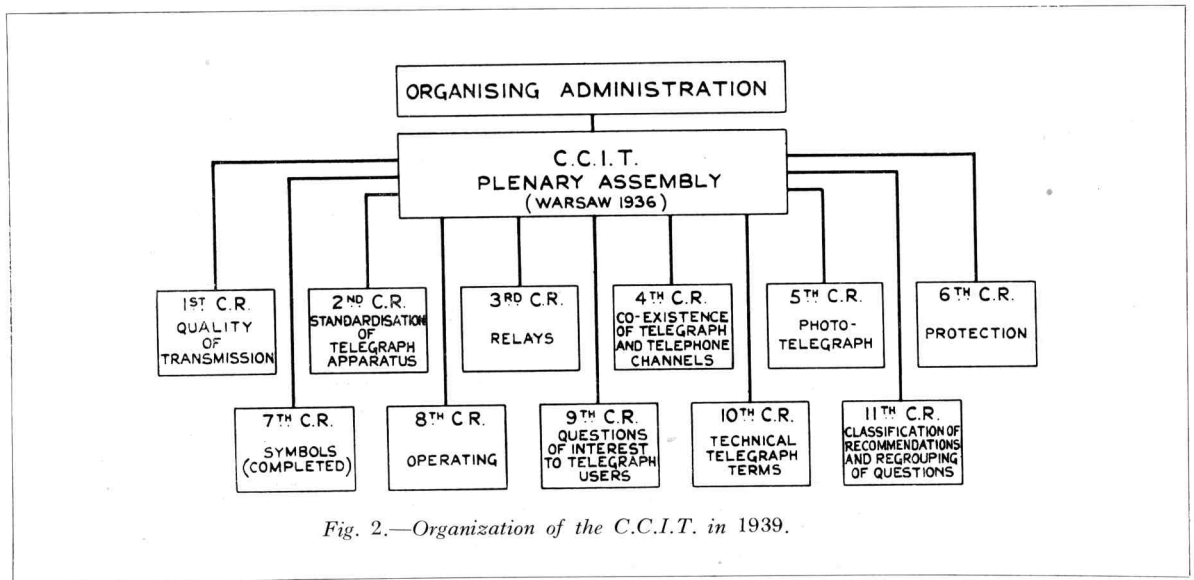

Fig. 2.—Organization of the C.C.I.T. in 1939.

5. THE BUREAU OF THE INTERNATIONAL TELECOMMUNICATION UNION

Article 17 of the Convention authorizes the establishment of a central office called the Bureau of the International Telecommunication Union. The Bureau is located at Berne, Switzerland, and consists of a Director and a staff. It forms, in fact, the Secretariat of the Union in a very comprehensive sense, and is placed under the supervision of the Government of the Swiss Confederation. The cost of the Bureau is borne by the Contracting Governments and other interested parties in accordance with provisions made in the regulations annexed to the Convention.

6. THE TECHNICAL CONSULTATIVE COMMITTEES

The Convention makes provision for, and the Administrative Conferences have set up, consultative committees for the study of questions—particularly technical questions—relating to the telecommunication services. On such questions these committees draw up “Avis” (recommendations) which are in due course submitted for the consideration and approval of an Administrative Conference. These “Avis” have no executive authority until approved by such a conference although, in practice, they are not infrequently applied by those concerned in advance of formal approval.

These committees are :—

- (1) Comité Consultatif International Téléphonique (C.C.I.F.).
(International Telegraph Regulations, Art. 56 and Annexe thereto).
- (2) Comité Consultatif International Télégraphique (C.C.I.T.).
(International Telegraph Regulations, Art. 103 and Annexe No. 2 thereto).
- (3) Comité Consultatif International des Radiocommunications (C.C.I.R.).
(International Radiocommunication Regulations, Art. 33 and Appendix 16).

Following the assembly of a preliminary committee in 1923, the C.C.I.F. was formed in 1924 as a telephone consultative body under the name of Comité Consultatif International (C.C.I.). At its inception it was independent of the International Telegraph Convention. The C.C.I.T. was set up at the International Telegraph Conference (Paris 1925), and the C.C.I.R. at the International Radiotelegraph Conference (Washington 1927). All three bodies are now covered by Art. 16 of the International Telecommunication Convention (Madrid 1932), and their functions and working arrangements are defined in the several Regulations which complete the Convention. At the same time the C.C.I. became the C.C.I.F.

7. THE C.C.I.F.

The C.C.I.F. is charged with the study of

technical questions and questions of operation and tariffication involved in international telephony. It controls its own finances and has a Secretariat which is independent of the Bureau of the Union. Its expenses are shared by the participating Administrations and private operating telephone companies.

The constitution of the C.C.I.F. comprises four organizations :—

- (a) The Plenary Assembly (A.P.)
- (b) The Committees of Rapporteurs (C.R.)
- (c) The Laboratory of the European Fundamental System of Reference for Telephone Transmission (S.F.E.R.T.)
- (d) The General Secretariat.

The Plenary Assembly controls the general activities and studies of the C.C.I.F. and fixes the date of the next meeting. It sets up the Committees of Rapporteurs, allocates their

duties and chooses the Secretary General ; it also approves the budget submitted by him, appoints auditors and examines their reports.

The Committees of Rapporteurs study new questions and submit reports and "Avis" (recommendations) for the consideration of the plenary session.

The S.F.E.R.T. serves as a centre for the measurements of transmission and co-ordination of transmission data relating to the telephone systems of European countries, carries out tests for, and at the expense of, Administrations and operating companies and, at the request of the Plenary Assembly or Committees of Rapporteurs, conducts experiments and tests relating to new questions. The cost of the S.F.E.R.T. is borne by the C.C.I.F.

The Secretary General keeps all correspondence, drafts the annual budget, prepares

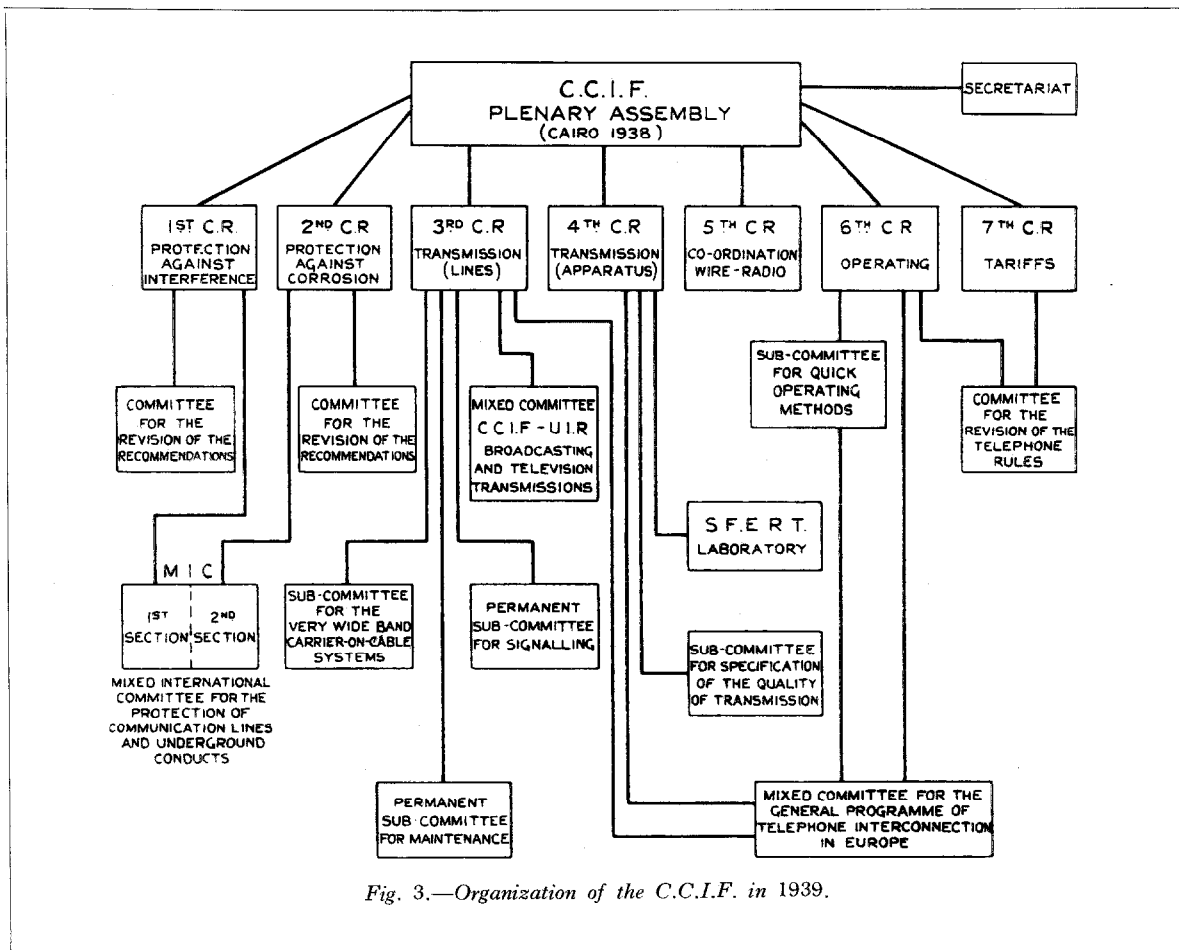
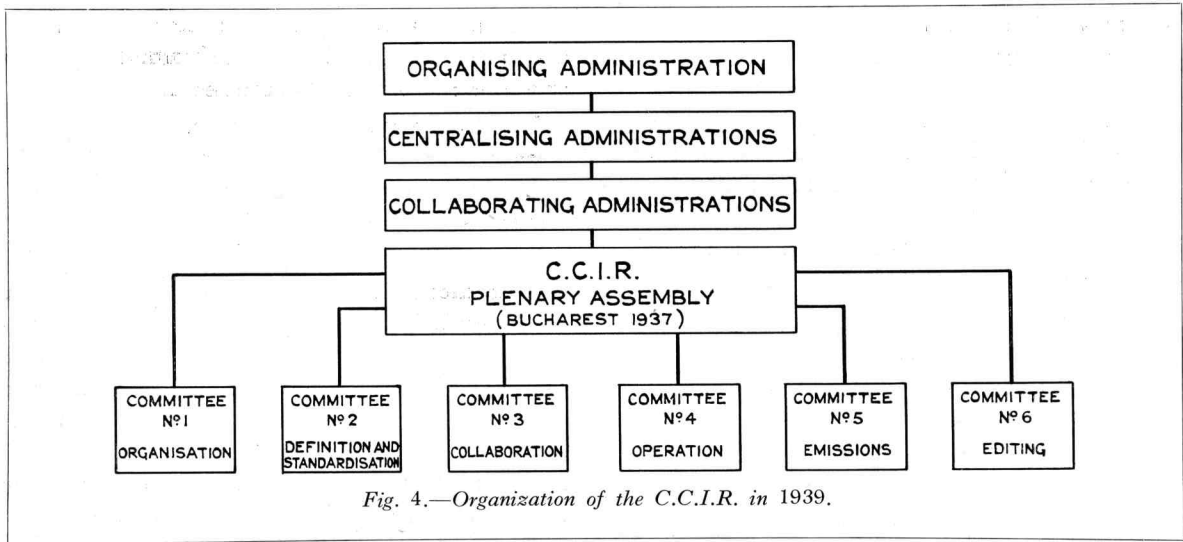

Fig. 3.—Organization of the C.C.I.F. in 1939.



the accounts, attends all meetings in a consultative capacity, draws up reports, etc. His address is :—

M. le Secrétaire Général du C.C.I.F.,
23 Avenue de Messine,
PARIS, 8.

The cost of the General Secretariat is chargeable against the C.C.I.F. budget.

8. THE C.C.I.T.

The C.C.I.T. is charged with the study of technical and operating questions relating to

telegraphy, submitted to it by Administrations and private enterprises—also with the study of tariff questions submitted to it by a plenipotentiary or administrative conference, or by at least twelve Administrations.

The secretarial work of the C.C.I.T., both at its meetings and during the interim periods, is performed by the Bureau of the International Telecommunication Union. There are no financial charges against the C.C.I.T. other than those of the Bureau; they are shared by the Administrations, Representatives and Observer-Experts who attend the meetings.

INTERNATIONAL ORGANIZATIONS

USUALLY REPRESENTED AT TELECOMMUNICATION CONFERENCES

A.I.I.R.M.—Association internationale des intérêts radio-maritimes.
 C.C.I.F.—Comité consultatif international téléphonique.
 C.C.I.R.—Comité consultatif international des radiocommunications.
 C.C.I.T.—Comité consultatif international télégraphique.
 C.I.N.A.—Commission internationale de navigation aérienne.
 C.I.R.—Comité international de la radio-électricité.
 C.I.R.M.—Comité international radio-maritime.

C.M.I.—Comité météorologique international.
 I.A.R.U.—International Amateur Radio Union.
 S. de N.—Société des Nations.
 U.I.R.—Union internationale de radiodiffusion.
 U.R.S.I.—Union radio-scientifique internationale.
 Chambre de commerce internationale.
 Conférence internationale des grands réseaux électriques à haute tension.
 International Federation of Radiotelegraphists.
 International Shipping Conference.
 International Shipping Federation.

The executive control of the C.C.I.T. between two consecutive meetings is vested in an Administration which volunteers for the duty of organizing the next meeting ; this Administration is called the Organizing Administration. The Organizing Administration convenes the meeting for which it has accepted responsibility, and its representative takes the Chair at the opening Plenary Assembly. At the opening session the assembly sets up the various committees necessary to deal with the questions submitted to the C.C.I.T. These committees in due course draft the "Avis" (recommendations) to be submitted for the approval of the closing Plenary Assembly. This assembly also reviews the general situation and draws up the new list of questions to be considered at the next meeting of the C.C.I.T. It sets up "Committees of Rapporteurs," each under the charge of a principal rapporteur who is a member of some particular Administration, and whose committee will, during this interval, study those questions allocated to it and draft "Avis" in reply to them. Although as far as practicable during this interval questions must be settled by correspondence, a principal rapporteur has the power (with the authority of his Administration) to call together the members of his committee for discussion. The closing Plenary Assembly finally appoints the Administration which is to organize the next meeting and fixes its approximate date and place.

9. THE C.C.I.R.

The C.C.I.R. is charged with the study of technical radio-electric questions and operating questions depending for their settlement principally on considerations of a technical nature. The procedure of the C.C.I.R., as far as the actual meetings are concerned, is similar to that of the C.C.I.T., but the interim organization between two successive meetings is somewhat different and consists of three voluntary bodies, viz. :—

- (a) The Organizing Administration ;
- (b) The several Centralizing Administrations ;
- (c) A number of Collaborating Administrations, private enterprises, and international organizations.

The Organizing Administration (as in the case

of the C.C.I.T.) undertakes to organize the next meeting and fixes the place and date.

The Centralizing Administrations each undertake to centralize, pursue the study of, report on and draft an "Avis" (recommendation) for some particular question.

The Collaborating Administrations, private enterprises and international organizations undertake to assist some particular Centralizing Administration in completing its report.

The Administrative Conference itself, or an Administration or private enterprise which has obtained sufficient support, may submit a question on which advice is desired to the C.C.I.R. The examination of this question is then undertaken during the period between the two Administrative Conferences by a Centralizing Administration assisted by its Collaborating Administrations, private enterprises, and international organizations. The conclusions arrived at by a Centralizing Administration, together with a draft "Avis" (recommendation), are sent to the Bureau of the International Telecommunication Union for general distribution. These reports then form the chief documents for study by the C.C.I.R. at the forthcoming meeting. Each is finally examined during the meeting by a special committee of the C.C.I.R., which agrees on an "Avis" (recommendation) on the subject. This "Avis" is submitted for approval at the closing Plenary Assembly of the C.C.I.R. and forms a part of the report of the C.C.I.R. Conference at the succeeding Administrative Conference.

10. CIRCULATION OF INFORMATION, ETC.

Administrations and private enterprises desirous of participating in, and undertaking to share the cost of, a meeting of the C.C.I.F., C.C.I.T., or C.C.I.R. address their notifications to the Bureau of the International Telecommunication Union, which communicates them to all Administrations and, in the case of the C.C.I.F., to that body also.

The Bureau of the Union is employed by the C.C.I.T. and C.C.I.R. for the general circulation of "Avis" (recommendations) and other matters relating to their procedure.

The C.C.I.F. issues its own information and documents through its own Secretariat. The

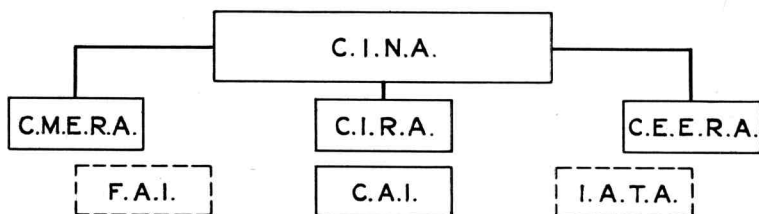

Fig. 5.—Organization of the aeronautical services in 1939.

Though operating under the Regulations of the Convention, the aeronautical services have been permitted a certain latitude in respect of services which are purely aeronautic. The organizing bodies are the C.I.N.A. and the C.A.I.

The chief aeronautical organizations are :—

C.I.N.A.—Commission internationale de navigation aérienne.

C.I.N.A. is affiliated to the League of Nations. Its members are Government representatives. Its representative attends the Telecommunication Conferences in the capacity of Observer-Expert.

C.I.R.A.—Comité international radioaéronautique.

C.I.R.A. is a permanent consultative committee set up by C.I.N.A.

C.M.E.R.A.—Conférence mondiale des experts radiotélégraphistes de l'aéronautique.

C.M.E.R.A. is convened by C.I.N.A.

C.E.E.R.A.—Conférence européenne des experts radiotélégraphistes de l'aéronautique.

C.E.E.R.A. is convened by C.I.N.A.

C.A.I.—Conférence aéronautique internationale (Central and Western Europe).

C.A.I. is convened by countries in turn. Its members are Government representatives. It is not officially associated with C.I.N.A. It is not represented at Telecommunication Conferences.

I.A.T.A.—International Air Traffic Association.

I.A.T.A. is a commercial association of air transport companies.

F.A.I.—Fédération aéronautique internationale.

F.A.I. is chiefly concerned with the interests of private flyers.

Aeronautical Publications

I.S.I.T.N.A.—Instructions sur le service international des télécommunications de la navigation aérienne.

I.S.I.T.N.A. is drafted and published by C.I.N.A.

R.S.I.T.A.—Règlements du service international des télécommunications de l'aéronautique.

R.S.I.T.A. is drafted and published by C.A.I.

Vol. I.—General communication instructions.

Vol. II.—Codes, stations, area boundaries, etc.

Bureau of the Union, however, advised by the C.C.I.F., undertakes the publication of :—

- General Telephone Statistics ;
- List of International Telephone Circuits ;
- Official Maps of the International Telephone System.

It also publishes the "Avis" (recommendations) of the C.C.I.F. in its Journal (*Journal des Télécommunications*, published by le Bureau de l'Union Internationale des Télécommunications).

II. ORGANIZATION OF THE AERONAUTICAL SERVICES

At the time of the Madrid Conference in 1932, the general Radiocommunication Regulations governed the operation of the Aeronautical services. As the latter expanded, however, it became evident that many of these Regulations were not suitable to a service which is so different in many respects from the mobile service of ships for which the International Regulations are mainly designed.

At Cairo, therefore, while the general observance by the Aeronautical services of the International Regulations was a specific requirement, provision was made for the introduction by the Aeronautical services of special regional Regulations applicable only to services which are exclusively aeronautical.

The organization of the Aeronautical radio services (July 1939) is still in a state of flux, and is under rapid development and consequent rearrangement at frequent intervals. The relation of the organization to the Telecommunication Convention is also unusual, since the organizing authority (the C.I.N.A.) only attends a Telecommunication Conference in the capacity of Observer-Expert, although its members are Government representatives.

At a meeting held in June 1939, the C.I.N.A. set up a permanent consultative committee for the study of radio-aeronautical technical and operating questions with the title of Comité International Radioaéronautique (C.I.R.A.). This committee follows the lines of the other consultative committees. It has its own Secretariat and its cost is shared by the C.I.N.A. with Administrations and others who are not

represented on the C.I.N.A. but who notify their adhesion to the Committee.

In addition to the C.I.N.A., there are at present (July 1939) three other bodies associated with the conduct of the Aeronautical services whose members are Government representatives :—

C.A.I.—International Aeronautical Conference (Central and Western Europe) ;

C.A.M.—Mediterranean Air Conference ;

C.A.E.B.B.—Aeronautical Conference of the Balkan and Baltic States.

Representatives of these bodies generally attend the meetings of the C.I.N.A. but do not attend the Telecommunication Conferences.

This same remark also applies to two commercial organizations, viz. :—

F.A.I.—International Aeronautical Federation, which is chiefly concerned with the interests of private flyers ; and,

I.A.T.A.—International Air Traffic Association, which is a commercial association of air transport companies.

Telephone Long Distance Efficiency

AN excellent illustration of telephone service was given to officials of the National Press Club in Washington recently when they sought to invite Lord Beaverbrook, the British publisher, to speak before it. First New York was telephoned, but the operator said he had gone to Montreal ; then a check of Montreal hotels ascertained that he had left for Ottawa ; at Ottawa it was discovered he was then flying to Toronto. The Toronto operator told the National Press Club officials that Lord Beaverbrook was over the airport, and she would call when he landed. She did and the invitation was extended. The telephone search at New York and the three Canadian cities only lasted around twenty minutes.

Extract from "Telecommunication Reports," Vol. 6, No. 9, October 5, 1939

Modern Broadcast Repeater Equipments

By R. A. MEERS and F. G. FILBY,

Standard Telephones and Cables, Limited, London

INTRODUCTION

THE use of broadcast repeaters in modern programme distribution systems involves the solution of a number of special problems. These problems have been the subject of considerable study in recent months, and have resulted in the design and production by Standard Telephones and Cables, Ltd., of an entirely new range of broadcast repeaters, together with the associated equalization, switching and remote control circuits.

At an early stage in this study it became clear that four main cases could be distinguished, these being based upon the output requirements of the repeaters. A special type of broadcast repeater has been designed to suit each case. The four repeaters, and the conditions for which they have been designed to cater, are as follows:—

Type 1.—The Type 1 broadcast repeater is designed to meet the conditions which arise at large switching centres. At such centres, the repeater is required to be capable of accepting a programme from any one of a number of circuits and of feeding the amplified signals simultaneously to all or part of a large group of lines. The group of lines concerned may include one or more lines to the local radio transmitter, a number of long distance circuits to other switching centres, and a large group of feeders to local rediffusion centres. The total number of output lines involved may be as high as 60 or even 100, but this number will be liable to variation from time to time. This latter condition introduces the necessary requirement that the level transmitted by the broadcast repeater to each line shall be substantially independent of the number of output lines involved at any given time.

Type 2.—The Type 2 broadcast repeater is designed to meet the conditions which arise at

switching centres where the number of output lines involved is considerably smaller than in the above case. Such conditions will, in general, occur where no rediffusion circuits are required. The repeater is again required to be capable of accepting a programme from any one of a number of circuits and feeding the amplified signals simultaneously to all or part of the group of output circuits; but the total number of circuits to be connected at any given time will, in this case, not exceed about eight, and may be as low as two. Here again, however, the level transmitted by the broadcast repeater to each line must be sensibly independent of the number of lines involved at any given time.

Type 3.—The Type 3 broadcast repeater is designed to meet the conditions which arise at switching centres where only one output circuit is required to be connected at any given time. The repeater should be capable of accepting a programme from any one of a group of circuits and feeding the amplified signals to any other line of the group. Which line is actually connected at any given time will, of course, depend upon the distribution required at that time, but the repeater should be so designed that the level transmitted to the output circuit is sensibly independent of which line is in use. This repeater may, in some cases, be used with advantage as an intermediate repeater.

Type 4.—The Type 4 broadcast repeater is intended solely for use at intermediate repeater stations in which it is used always in the same line. It should, however, be capable of reversal in order that the line may be available for transmission in either direction as required. It has the advantage, as compared with Type 3, that the maximum output level obtainable is higher, but it lacks those advantages which accrue from the use of a low impedance output.

GENERAL REQUIREMENTS

In addition to the above special conditions, all broadcast repeaters must have certain common features in order to meet the stringent requirements of modern programme distribution systems.

The repeaters should be capable of handling a wide frequency range, the gain of the repeaters being substantially constant over this frequency range when no equalizers are in circuit; while the shape of the gain-frequency characteristic should be independent of the gain setting. Further, the shape of the gain-frequency characteristic and the gain should be adjustable so that all the repeaters in a given station, or in a group within the station, may be given identical characteristics. The last feature is of importance firstly, in order that during switching operations any repeater may be immediately utilized without adjustment, and secondly, so that in the case of a failure of one repeater occurring during service, a second may be substituted with a minimum of delay.

In addition to the above, the repeaters must be stable and unaffected by normal battery variations, and the harmonic distortion introduced by the repeater must be very small, even at maximum output level and at the extremes of the frequency range.

DESIGN FEATURES

In considering the design of a range of repeaters to meet the above conditions, one of the first points to settle is the method whereby a variable number of lines may be connected to the output of the repeater.

In the past, the method has been to divide the repeater into main and auxiliary amplifiers. The input of the main amplifier was connected to the incoming line, and the output of a separate auxiliary amplifier was associated with each outgoing line. The output impedance of the main amplifier was made as low as was consistent with the use of small valves without overloading, and in general was between 3 000 and 6 000 ohms. Each auxiliary amplifier consisted of two valves in push-pull whose grid circuits were connected directly to the output in the main amplifier. With this arrangement each output line was segregated from the other

circuits, and a reasonable number of auxiliary amplifiers could be fed from a single main amplifier. In practice, a station might have a small number of main amplifiers and a large number of auxiliary amplifiers with provision for connecting any of the auxiliary amplifiers to any of the main amplifiers. The wiring and switchgear necessary for these connections caused considerable capacity shunt across the output of the main amplifier and a corresponding loss of gain at the high frequencies. Owing to this limitation, it was not possible to connect more than 10 or 15 auxiliary amplifiers to any main amplifier, and this in many cases is not sufficient. Further, when large numbers of auxiliary amplifiers are used, the method becomes impracticable on the grounds of excessive cost, power consumption and space requirements. The repeaters also proved to be incapable of meeting the modern requirements of output power and non-linear distortion.

An alternative is to design a repeater having a high output power and low output impedance so that the voltage produced at the output is practically independent of the impedance to which it is connected over a wide range of impedance values. With such an arrangement, lines could be connected directly in parallel at the output of the repeater, the only limitations being that the combined impedance of the lines should be large compared with the panel output impedance, and that retransmission of noise or other disturbances from any one line to any other with which it is in parallel should be negligible. Such an arrangement was not possible when the above type of equipment was designed, without using either high anode voltages or an excessive number of valves in parallel. Recent developments in valve design and the introduction of the negative feedback principle have, however, brought such a design within practical limits, and this principle has been employed in each of the repeaters, Types 1, 2 and 3, described in this article.

The negative feedback principle has been so applied in these repeaters that the effective output impedance is reduced to a value considerably below the nominal output impedance and, since adequate power is available in the last stage, the latter has itself been made small.

Further, the application of negative feedback has resulted in the reduction of the non-linear distortion to a very low value.

A second general point affecting the design of these repeaters concerns the method of equalization. The modern practice in this respect is that the equalization associated with a repeater shall correct the characteristic of the line connected to the input of that repeater. The equalizer may be in the form of a separate line equalizer which is electrically independent of the repeater, or, alternatively, may be effectively part of the repeater circuit in that it controls the shape of the gain-frequency characteristic.

If the latter form is employed, it is necessary so to design the equalizer that it can be rapidly changed when the input circuit is changed. Study of a number of typical circuits led to the adoption of a scheme which combines both of the above methods. The arrangement is shown in Fig. 1. A constant impedance equalizer in the line provides the major portion of the equalization, while an equalizer which is effectively in the feedback path of the repeater provides normally for residual adjustments. Such an arrangement avoids undue complication in the constant impedance equalizer, while a simple tuned circuit usually suffices in the feedback equalizer. The latter is mechanically separate from the repeater, and is switched to suit the particular input circuit in use.

The attenuator pads shown in Fig. 1 are included so that the loss of all lines which may be associated with a given repeater can be built out to a definite value, the pads being included only when the line is used for input purposes.

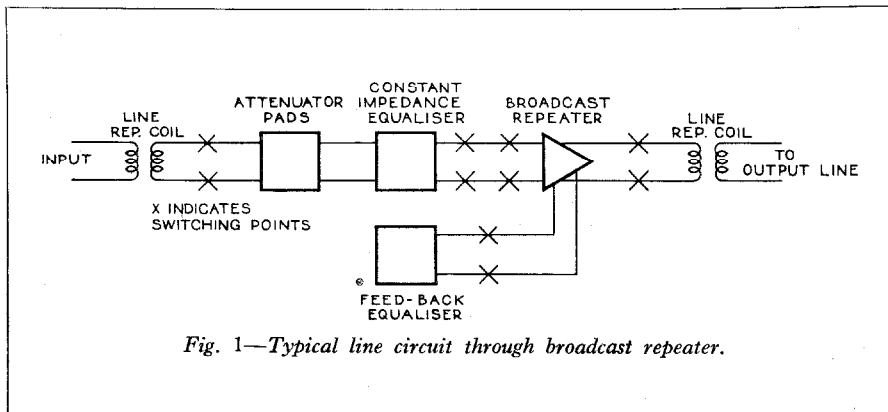

Fig. 1—Typical line circuit through broadcast repeater.

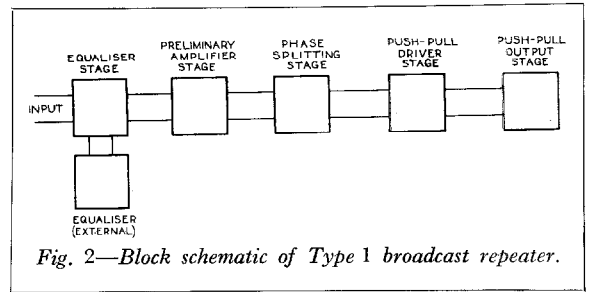

Fig. 2—Block schematic of Type 1 broadcast repeater.

Thus the necessity for gain adjustments during switching is avoided.

GENERAL DESCRIPTION OF REPEATERS

Type 1.—This, the largest repeater in the range, consists of five stages of amplification, as shown in the block schematic in Fig. 2. As will be seen, the first stage is employed as an equalization stage. The equalizer is inserted in the feedback circuit associated only with this stage. The advantage of equalizing in this low level part of the circuit is that the harmonic production is so small that any increase due to the reduction of feedback will not affect the overall distortion of the complete amplifier. The output from this stage passes to a preliminary amplifier stage, and then through a phase-splitting valve to a push-pull driver stage which feeds the push-pull output stage. There is a total of nine valves in the repeater, one in each of the first three stages, two in the driver stage and four (in parallel push-pull) in the output stage. With the exception of an input and an output transformer, resistance capacity coupling is used throughout to keep phase change low, and thus maintain circuit stability. The output transformer is tapped so that

nominal values of output impedance of either 16 ohms or 8 ohms can be obtained. The use of negative feedback, as mentioned above, reduces the effective impedance to a value considerably below these figures. When the lower impedance output winding is used, better load reg-

ulation is obtained than when the higher winding is used but, on the other hand, with the higher impedance winding, a higher maximum output level is obtainable into each line.

Gain control is provided in 5 decibel steps by means of soldered tappings on the coupling between the equalization stage and the preliminary amplifier stage; it is inserted at this point so that noise originating mainly in the first stage may be reduced as the gain is reduced. In addition, fine gain control in 20 steps of 0.5 decibel is provided by a knob-controlled attenuator in the input.

An idea of the mechanical construction of the

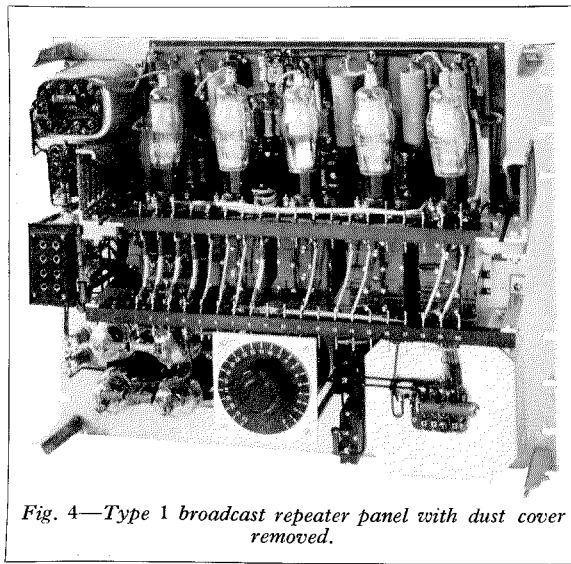

Fig. 4—Type 1 broadcast repeater panel with dust cover removed.

the output of the second stage to the input circuit of the first stage. In order to obtain the required output three valves are used in parallel in the output stage. The nominal impedance of the output winding is 75 ohms, but the application of negative feedback brings the effective output impedance considerably below this figure. Equalization is obtained by connection of suitable tuned circuits in the feedback path, but mechanically external to the panel. Gain control is by fine and coarse attenuation adjustments in the input of the repeater.

Figs. 5 and 6 show this repeater with and without the dust cover. Except for the input,

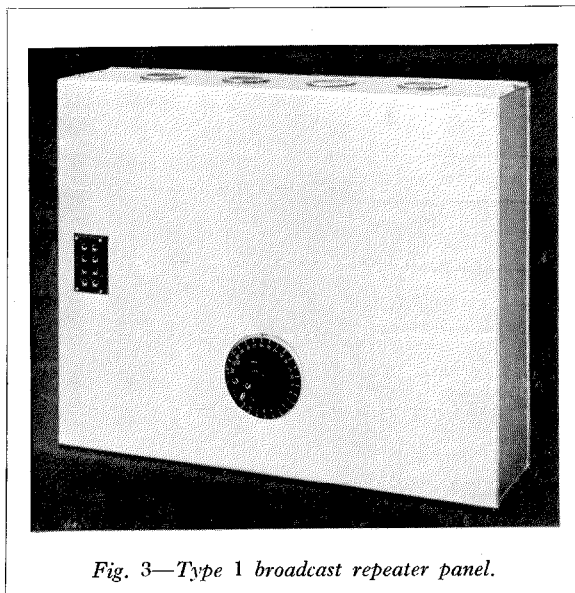

Fig. 3—Type 1 broadcast repeater panel.

repeater is obtainable from Figs. 3 and 4, which show the panel with and without the dust cover respectively. It will be seen from Fig. 3 that the panel is totally enclosed except for the gain control potentiometer and the input and output U-links. A special anti-vibration mounting used for all valves, except in the push-pull output stage, reduces microphonic noise in the repeater to a very low value; this mounting is shown in Fig. 4. Table I gives details of size, weight, etc., as compared with the other repeaters of the range.

Type 2.—This repeater is intended for feeding a medium number of lines, and consists of two stages of amplification. Apart from input and output transformers the circuit is choke capacity coupled, negative feedback being taken from

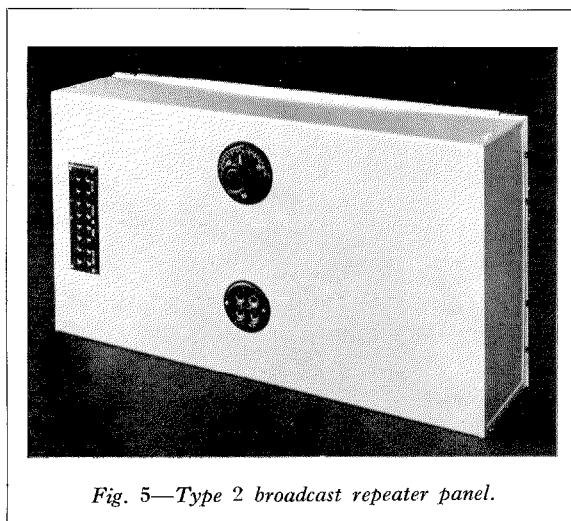

Fig. 5—Type 2 broadcast repeater panel.

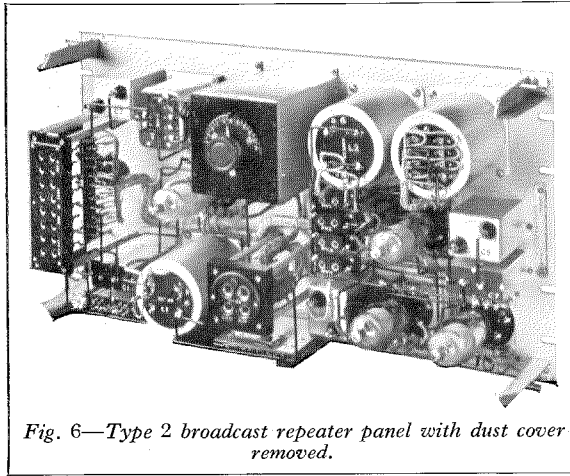

Fig. 6—Type 2 broadcast repeater panel with dust cover removed.

output and equalizer U-links, the gain control potentiometer and the filament control jacks and

Type 4.—This repeater is also intended for feeding a single line, but has a 500-ohm output impedance. The circuit is electrically similar to the two previous types, with the difference that, since a low output impedance is no longer required, the negative feedback arrangement is in series with the output transformer, and not in parallel, as in the previous two cases. In this panel the fine gain control, as well as the equalization, is obtained from the feedback circuit.

From the mechanical standpoint this panel is very similar to the Type 3 panel. Figs. 10 and 11 show views of this repeater with and without dust cover.

PERFORMANCE

The performance which has been obtained

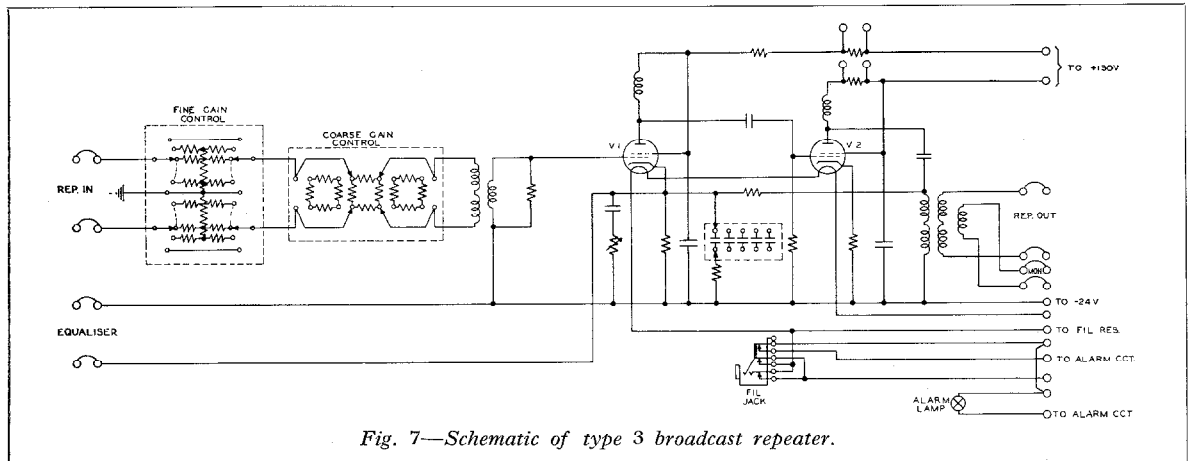

Fig. 7—Schematic of type 3 broadcast repeater.

alarm lamp, the apparatus comprising the panel is totally enclosed. Details of the size, weight, etc., are given in Table I.

Type 3.—This repeater is intended for feeding a single line from a low impedance output source, and is electrically similar to the Type 2 repeater; but as considerably less output power is required, a single valve is used in the output stage, and both the nominal and effective output impedances are higher. A schematic of this repeater is shown in Fig. 7.

Mechanically the panel is similar to, but smaller than, the Type 2 repeater, as will be seen from the comparison in Table I. Figs. 8 and 9 show this repeater with and without the dust cover.

with the various repeaters in the range may be judged from the following summary.

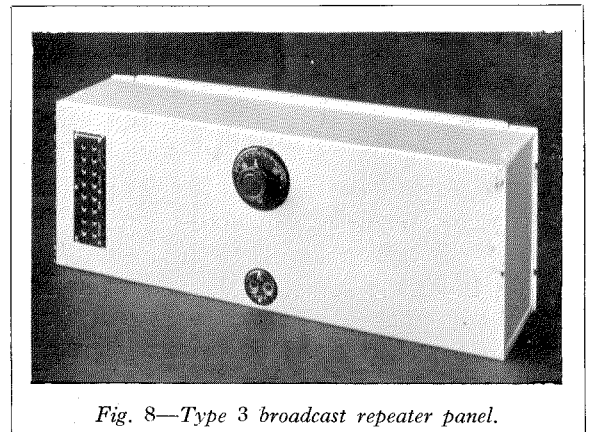

Fig. 8—Type 3 broadcast repeater panel.

Gain

The maximum unequalized gain of the repeaters is approximately 45 db. The gain of any of the panels may be adjusted, either in steps of 5 or 10 db. by means of soldered connections, or by steps of 0.5 db. by means of a knob-controlled attenuator, except in the Type 4 panel, in which fine control is by means of a slide wire potentiometer. The range of control provided by these means is such that the gain can be adjusted to within 0.25 db. of any required value from 0 to 45 db.

In the case of Types 1, 2 and 3 repeaters which are liable to wide variations of output load, the gain is to a small extent dependent upon the output load. The change of gain

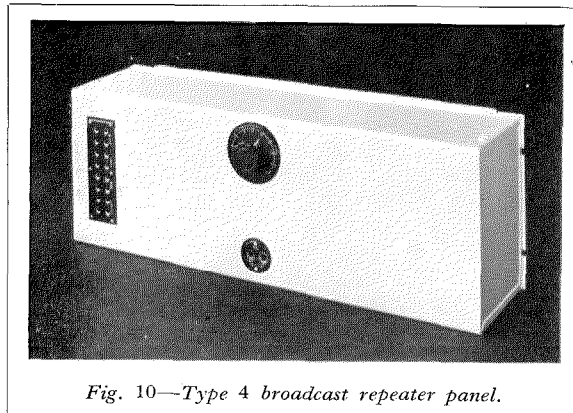

Fig. 10—Type 4 broadcast repeater panel.

example, are typical curves showing the extremes of the adjustment range on the Type 3 repeater.

TABLE I

Type of Repeater	1	2	3	4
Maximum number of output lines ..	60-100	8	1	1
Height	15 3/4 in.	8 3/4 in.	7 in.	7 in.
Width	19 in.	19 in.	19 in.	19 in.
Depth, including Dust Cover..	4 3/4 in.	4 3/4 in.	4 3/4 in.	4 3/4 in.
Weight	45 lb.	30 lb.	26 lb.	22 lb.

from maximum to minimum value of the latter does not, however, exceed 1-2 db.

Gain-Frequency Characteristic

The unequalized gain-frequency characteristic of any of the repeaters is flat to within 0.5 db. over the frequency range from 30 to 8 000 p : s. In order that the characteristics of various panels may be closely matched, provision is made on the Types 1, 2 and 3 repeaters for slight adjustment of the shape of this characteristic at high and low frequencies by means of tapings on a condenser and a resistance respectively. Figs. 12 and 13, for

In each case several intermediate curves are obtainable.

Input Impedance

The input impedance of each of the repeaters is nominally 500/0° ohms. In practice the impedance obtained may have a modulus of 500 ± 30 ohms with an angle not exceeding 5°. These limits are only approached at the extremes of the frequency range, the major portion of which will meet much closer limits.

Output Impedance

As mentioned above, negative feedback is applied in repeaters Types 1, 2 and 3 in such a way that the effective output impedances are reduced to values considerably below the nominal output impedances, which are themselves low in comparison with 500 ohms. The nominal values of the output impedances, together with approximate figures for the effective impedances obtained, are given in Table II.

The Type 4 repeater is designed to have an output impedance of 500/0° ohms and the value obtained in practice will have a modulus within 30 ohms of this value and an angle not exceeding 5° over the whole frequency range.

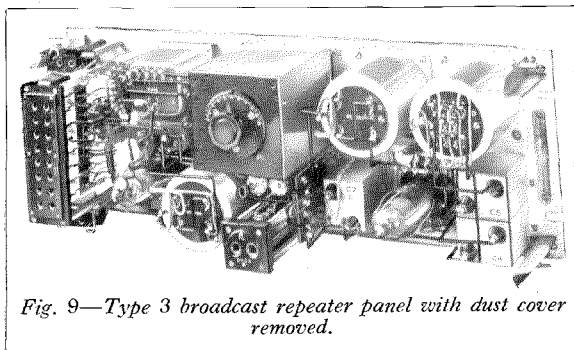

Fig. 9—Type 3 broadcast repeater panel with dust cover removed.

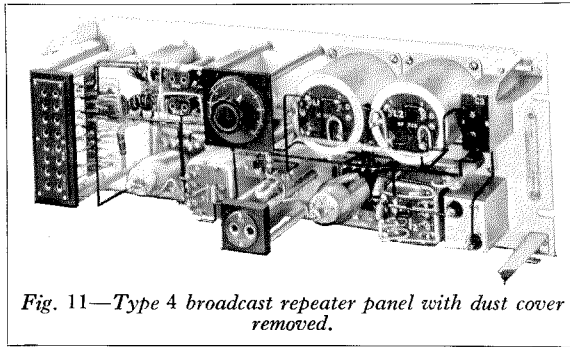

Fig. 11—Type 4 broadcast repeater panel with dust cover removed.

Non-Linear Distortion

The use of negative feedback in these repeaters has reduced non-linear distortion to an extremely low value at all output levels which are more than about three decibels below

Noise

The use of special anti-vibration mountings and valve sockets has resulted in the reduction of noise at the output of the repeaters to a low value, and in a marked freedom from microphonicity due to extraneous disturbances.

POWER REQUIREMENTS

The repeaters are designed to operate from normal 24-volt and 130-volt repeater station batteries. Since indirectly heated valves (Types 4328A and 5A/102A) are used throughout, it has been possible to utilize the two batteries in series to obtain a 154-volt anode supply.

Since the heater voltage required by these valves is 7.5 volts, it has been possible to operate the valves in a number of parallel circuits, each of which has a pair of valves in series. The

TABLE II
COMPARISON OF THE OUTPUT IMPEDANCES OF THE VARIOUS TYPES OF REPEATER

Type of Repeater	1		2	3	4
Maximum number of output lines	60	100	8	1	1
Nominal Output Impedance	16 Ω	8 Ω	75 Ω	150 Ω	500 Ω
Effective Output Impedance (approx.)	2 Ω	1.5 Ω	20 Ω	50 Ω	500 Ω

the maximum obtainable. This maximum depends upon the value of the output load and also, in the case of the Type 1 repeater, upon which of the two output windings is used.

Table III gives, for the various types of repeater, a typical series of figures for the output levels at which the total harmonic content is 40 db. (1% harmonics) and 52 db. (0.25% harmonics) below the output level, these figures being based on a fundamental frequency of 1 000 p : s, and taken at various values of output load.

When other fundamental frequencies are considered, variations in these figures are small, but are greatest at the lowest frequencies. If harmonics are measured using a 30 p : s fundamental, the corresponding figures for output level will be 1-2 decibels lower than those given in the table.

total battery drains required by the various repeaters are set out in Table IV.

As the circuits are fully decoupled, it is possible to use rectified and smoothed A.C. supplies, but the stringent requirements have made it impracticable to operate the heaters directly from alternating current.

As a result of the use of negative feedback, the gain of the repeaters will not vary with any normal variations in supply voltages.

EQUALIZATION

The general principle which has been adopted

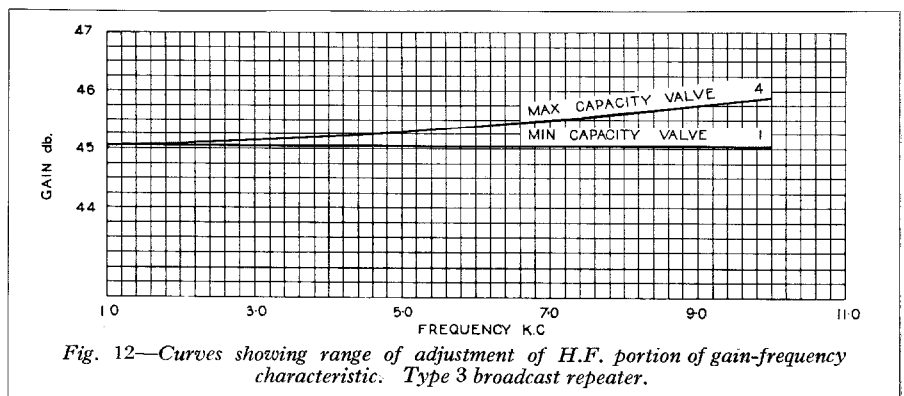

Fig. 12—Curves showing range of adjustment of H.F. portion of gain-frequency characteristic. Type 3 broadcast repeater.

for equalization in connection with these repeaters is outlined above. The input circuit is equalized by means of a combination of a constant impedance network in the line and a tuned circuit which, while being mechanically separate, effectively shunts the feedback resistance in the repeater.

One equalizer is provided for each line which may be used as an input circuit, and comprises the components for both the constant impedance network and the tuned circuit, which may be so strapped on installation as to produce the required characteristic. Switching is so arranged that, when a given circuit is connected to the input of a repeater, the appropriate equalizer is also connected. Each equalizer is in the form of a panel suitable for mounting on a standard 19-inch rack, is equipped with a 4 $\frac{3}{4}$ -inch dust

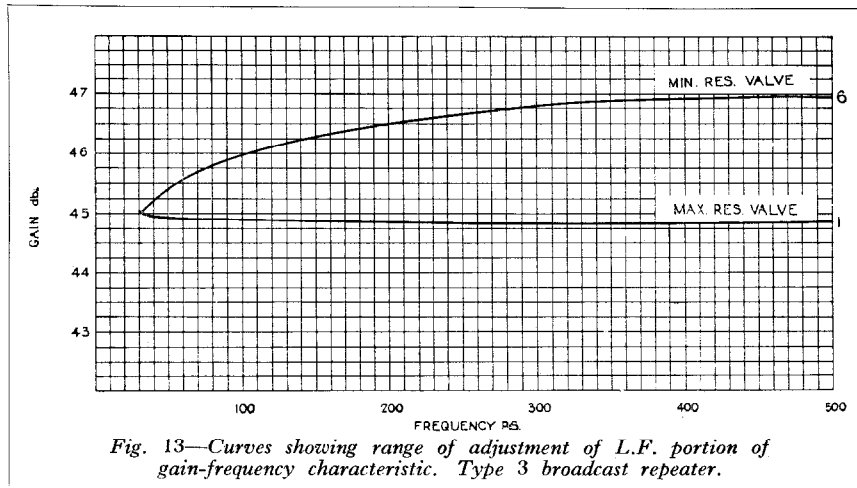

Fig. 13—Curves showing range of adjustment of L.F. portion of gain-frequency characteristic. Type 3 broadcast repeater.

is usual to employ the constant impedance line equalizer to provide low frequency correction while the feedback equalizer corrects the high frequencies. The equalization of circuits of this type may be carried out in a straightforward manner to a high degree of accuracy. When, however, the case of non-loaded cable or open-wire line is considered, it is usually necessary to obtain the major part of the required equalization over the whole frequency

TABLE III

TYPICAL FIGURES FOR THE MAXIMUM OUTPUT LEVEL WHICH CAN BE TRANSMITTED TO EACH LINE FOR VARIOUS OUTPUT LOADS AND FOR VARIOUS DEGREES OF HARMONIC CONTENT IN THE OUTPUT, BASED ON A 1 000 P : S FUNDAMENTAL.

OUTPUT LOAD (ohms)	EQUIVALENT NUMBER OF LINES	OUTPUT LEVEL (db. ref. 1 mW into 600 ohms)					HARMONICS
		REPEATER TYPE					
		1 (a)*	1 (b)†	2	3	4	
500	1	+22.6	+19.1	+23.0	+19.0	+20.0	} 1% i.e. 40 db's below fundamental
250	2	+22.5	+19.0	+22.5	—	—	
62.5	8	+21.5	+18.0	+17.0	—	—	
20	25	+19.0	+15.5	—	—	—	
10	50	+16.0	+13.0	—	—	—	
500	1	+20.6	+17.1	+20.8	+17.0	+19.0	} 0.25% i.e. 52 db's below fundamental
250	2	+20.5	+17.0	+20.2	—	—	
62.5	8	+19.0	+16.0	+16.5	—	—	
20	25	+16.0	+14.0	—	—	—	
10	50	+11.0	+11.5	—	—	—	

* Using 16-ohm output winding.

† Using 8-ohm output winding.

cover, and may require up to 5 $\frac{1}{4}$ inches of vertical rack space.

The values of components required in the equalizer will vary widely with different types of line. In the case of loaded cable circuits it

range by means of the constant impedance line equalizer, while the feedback equalizer is employed to obtain the residual correction.

Fig. 14 shows a case in which the equalizers are used to compensate for the attenuation of

TABLE IV
COMPARISON OF THE VALVES AND BATTERY DRAINS OF THE VARIOUS REPEATERS.

Type of Repeater	1	2	3	4
Maximum number of output lines ..	60-100	8	1	1
Total number of valves	9	4	2	2
Number of 4328A valves	5	4	2	2
Number of 5A/102A valves	4	—	—	—
Drain on 24V battery _v	3.1 amps.	0.88 amp.	0.44 amp.	0.44 amp.
Drain on 130V batter _v	165 mA	32 mA	16 mA	16 mA

a particular section of a non-loaded broadcast circuit. Curve A is the attenuation characteristic of a 36-kilometre length of 1.1 millimetre non-loaded cable, while curve B is the unequalized gain characteristic of the repeater. Curve C, indicated by crosses, shows the combined gain characteristic of the repeater and a constant impedance network which is designed to equalize approximately the given line. The feedback equalizer is then adjusted to produce a slight resonance at approximately 200 p : s, with the result that a final gain characteristic for the combination of the complete equalizer together with the repeater is obtained as indicated by the circles, and which, as will be seen, approximates very closely to the line attenuation curve.

SWITCHING

An important component of any programme distribution scheme is the system which is used to switch the various lines to the repeaters as

required at any given time. It will be appreciated that widely diverse conditions arise with the large variations in the numbers of lines and repeaters which occur at different stations, and these will inevitably lead to wide variations in the switching equipments.

Referring again to Fig. 1, it will be seen that the points at which switching is required are those marked with a cross, it being remembered that a number of lines may be connected in parallel at the output of the repeater. It will be appreciated that if suitable jacks or U-link sockets are equipped at these points, the necessary switching may be carried out by means of patching with cords and plugs. This method, in fact, proves to be satisfactory and most economical at stations where the amount of switching is small, but is quite impracticable at larger centres, since it becomes cumbersome, slow and extremely liable to wrong connections. An improvement may be obtained by the use of

groups of telephone-type keys in place of the jacks and cords, but even this method does not fulfil the requirements at main switching centres; for such cases, it has been necessary to design schemes which, while being far more complicated mechanically, provide fast, straight-forward and fool-proof operating conditions.

In one such arrangement the switching is carried out automatically by means of relays and selectors operated

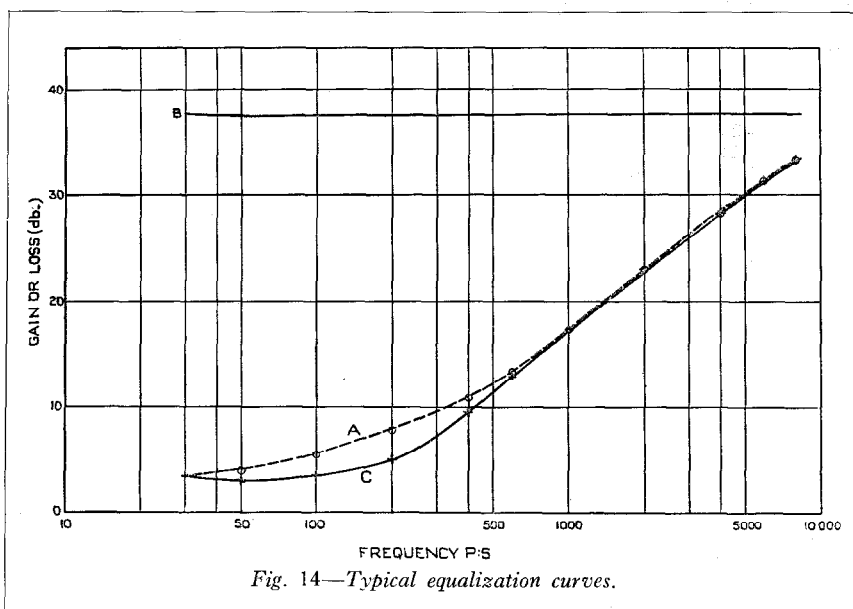
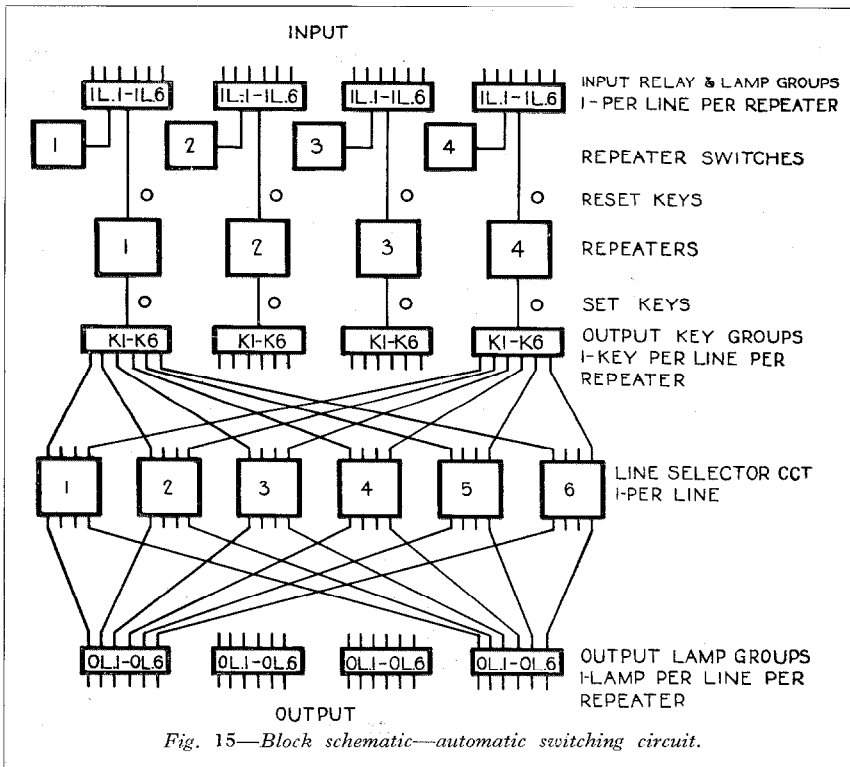

Fig. 14—Typical equalization curves.

indirectly from a control panel on which the required connections are preset. The system provides complete flexibility independent of the number of repeaters and lines involved, and covers the two cases, firstly where the circuits are two-wire, i.e., the same pair is used for transmission in either direction, and secondly, where the circuits are four-wire, i.e., different pairs are available for transmission in the two directions.

In a "preset" switching method, the necessary switches, keys, etc., are set to correspond with the circuit connections required for the next programme while one programme is running, the changeover being instantaneously effected at the required moment by the operation of two push-button keys only. The general arrangement of the switching gear is shown in block schematic form in Fig. 15, while Fig. 16 shows the control panel in diagrammatic form, the method of operation being as follows :—

The operator sets the switch for any given repeater to the input line from which he requires to take the programme, and then presses the relevant push-button keys at the bottom of the panel corresponding to the lines to which the programme is to be passed. These operations merely prepare the circuit and nothing happens until he presses, first the "reset," and then the "set" keys. On operation of these keys the programme circuits last used are cleared down, and the new programme circuits are then connected up automatically in accordance with the arrangement preset on the control panel. At the same time, lamps mounted behind the circuit designation strips of this panel are lit, giving an illuminated record of the conditions existing at the time. Immediately these lights appear, the equipment on the control panel is thrown out



of service, and the operator is then free at any time while that programme is running to reset the circuit for the next programme. Such an arrangement has the following advantages as compared with direct switching methods :—

- (a) The routing of programmes can be seen at a glance, and any faulty connections located immediately.
- (b) Since it is a preset method, the operator, instead of having to change the routing in a short space of time between programmes, can do it any time while the existing programme is running. This reduces very considerably the possibility of error.
- (c) Where means for the remote control of intermediate repeaters is provided at the switching station, this control can be effected automatically by the programme switching equipment. The operation is thus simplified and the equipment is made more nearly fool-proof.
- (d) Full automatic operation enables the equipment to be completely interlocked so that cross connection of programmes is impossible.

The only faulty connection which can occur with this system is an incorrect routing of programmes. Since the very essence of the equipment is to provide complete flexibility, the choice of routing must obviously be left with the operator, and it is fundamentally impossible to prevent wrong routing due to the operator setting up the control panel incorrectly.

The particular arrangement shown on Fig. 15 covers four repeaters and six lines, any one of which may be used either as an outgoing or incoming line. The repeater switches, which are those on the control panels already described, provide for the preselection of the required input line. Similarly, the keys K1-K6 are those at the bottom of these panels, and provide for the preselection of the required output lines.

IL.1-IL.6, etc., indicate both the indicator lamps which are used to illuminate the circuit designations on the control panel and the relays which are associated with the incoming lines, while Line Selector 1, Line Selector 2, etc., represent the selector circuits associated with the outgoing lines.

The desired connections are set up on the

switches (Repeater Switch 1, etc.) and keys K1-K6 on the control panel.

The "reset" key corresponding to the repeater whose programme it is required to change is operated. This causes the existing input connection to be broken down, and prepares the circuit for the new connection by the operation of the "set" key. Further, it causes the selectors corresponding to all lines used as output circuits in the existing connection, and also those corresponding to all lines required as output lines in the new connection, to be driven to their home position.

The "set" key of the repeater under consideration is then operated, causing the appropriate relays in the groups IL.1-IL.6 to operate, thus connecting the required input line, together with its associated equalizer and attenuator pads, disconnecting the line from the output groups and lighting the input indicator lamp. At the same time the selectors corresponding to the required output lines are all stepped round to the contact corresponding to the given repeater. The output indicator lamps are illuminated from subsidiary levels on the selectors. The preset switch and keys may then be restored and a new set-up prepared.

REMOTE CONTROL OF REPEATERS

In addition to the control of line connections at a switching centre, it is frequently desirable for the operator to control the intermediate broadcast repeaters in the repeatered circuits terminating at that switching centre. These intermediate repeaters, being unidirectional devices, are required to be reversible to allow the circuit to be used for transmission in either direction. Further, in order to avoid delays and confusion

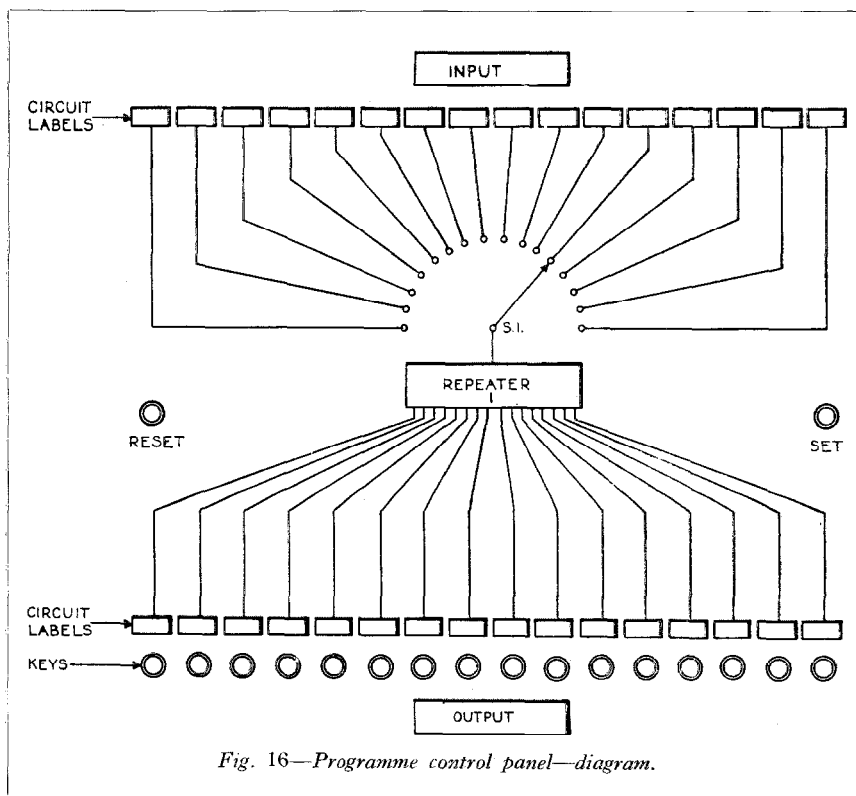

Fig. 16—Programme control panel—diagram.

it is desirable that the operator at the switching centre shall have the facility of switching the repeaters on or off as required.

Three conditions of the programme transmission circuit are envisaged:—

(a) *Manual Operation*

In which the operator at each repeater station has control of his own, and *only* his own, equipment.

(b) *Semi-Automatic Operation*

In which the operator at the control terminal controls not only his own repeaters, but also, by the operation of a key, all intermediate repeaters in the transmission circuit.

(c) *Automatic Operation*

In which control of the intermediate repeaters in the transmission circuit is effected automatically by the programme switching equipment at the control terminal.

Methods have been devised whereby remote control may be carried out either by A.C. or D.C. signalling. For the majority of cases a D.C. method appears to provide the most economical solution. In this method two specific types of signal are used, the first for controlling the filament circuits of the repeaters, and the second for controlling the direction of transmission.

Briefly the general method of operation is as follows:—

When the repeater filaments are to be switched on, a signal is sent from the control terminal, either semi-automatically, i.e., under control of the operator at that station, or automatically, under control of the automatic broadcast switching circuit. On reaching the first repeater station down the line, this signal causes the filament circuit to be completed, and when the repeater at that station reaches its operation condition, i.e., when anode current commences to flow, a check signal is sent back from the repeater station to the control terminal, this check signal being registered by the circuit at the control terminal. Also from the first repeater station, the filament signal is repeated down the line towards the second repeater station. At this second station a similar series of operations takes place, the check signal sent back in this case being repeated

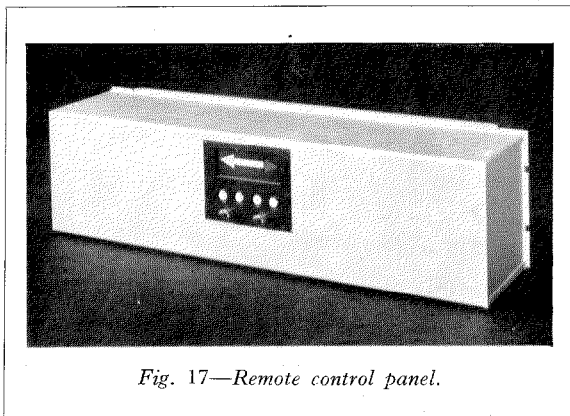

Fig. 17—Remote control panel.

directly by the first repeater station, so that it finally arrives at the control terminal and is similarly registered. This sequence of operations is repeated as many times as there are repeaters in the line, so that a number of check signals equal to the number of repeaters in the line will be received at the control terminal; these are counted by a suitable circuit, and a visual indication is given when the correct number of check signals has been received.

When, at any subsequent time, it is desired to switch off the repeaters in the line, an exactly similar series of operations will take place; but in this case the check signal is sent back to the control station and the forward signal to the next repeater station, upon cessation of anode current. At the end of them a further visual indication will be given at the control terminal.

When the repeaters in the line are to be reversed, a reversing signal may be sent from the control terminal either manually, by the operator of that station, or automatically, under control of the broadcast switching circuit. In a similar manner to the arrangements described for the filament control signal, this signal, having been operative at the first repeater station, sends a check signal back to the control terminal, and repeats the reversing signal in the direction of the second repeater station. Similarly, the second repeater station sends a check signal which is repeated at the first repeater and finally arrives at the control terminal, and at the same time repeats the signal again down the line. Thus the check signals arrive at the control terminal and are registered; when the required number has been received a visual indication is given at that terminal.

It should be noted that in this arrangement all the repeaters in the line are, when the filaments are first switched on, in a predetermined direction. Whatever the direction of the line immediately before the filament circuits are switched off, this normal direction is restored by that operation. Further, it should be noted that the check signals throughout are exactly similar to the outgoing signals for corresponding operations.

The equipment which provides these facilities comprises a combined relay and control panel at the control station and at each intermediate station. It is designed to mount on the standard type of rack, and the control equipment includes a visual direction indicator and lamps showing the state of the filament circuit etc., together with the necessary control keys. An example of the panel is shown in Fig. 17.

Where remote control of intermediate repeaters is provided, a comprehensive alarm system should be provided so that an immediate warning is given at the control station in the event of the failure of any intermediate repeater in the transmission line. The system described above provides this facility in addition to the normal local alarms, together with means

whereby the control station operator may rapidly determine the location of the failure.

CONCLUSION

The repeaters and associated apparatus described above provide a new solution to some of the problems involved in the engineering of broadcast networks. The value of the new features has already been demonstrated in cases where large numbers of output circuits are involved to provide for rediffusion services in addition to the normal broadcast network. In such cases it would have been difficult and expensive to provide the required facilities with the older type of repeater, and even if it had been possible, it is doubtful whether the final results would have been as good as those obtained with the new method. On the other hand, in cases where only a few lines are involved, the smaller repeaters of the range provide an economical solution, giving improved electrical characteristics as compared with the earlier types of repeater, while the centralization of control by means of automatic switching and remote control results in fast operating, together with low fault liability.