

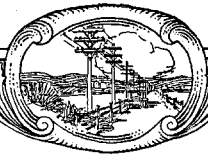

ELECTRICAL COMMUNICATION

OCTOBER 1938

Vol. 17, No. 2



ELECTRICAL COMMUNICATION

A Journal of Progress in the
Telephone, Telegraph and Radio Art

H. T. KOHLHAAS, EDITOR

EDITORIAL BOARD

E. A. Brofos G. Deakin E. M. Deloraine P. E. Erikson F. Gill
W. Hatton R. A. Mack H. M. Pease Kenneth E. Stockton C. E. Strong

Issued Quarterly by the

International Standard Electric Corporation

67 BROAD STREET, NEW YORK, N.Y., U.S.A.

Volume XVII

October, 1938

Number 2

	PAGE
C.C.I.F. MEETING OF TECHNICAL COMMISSIONS (1st to 5th incl.), OSLO, June 20-July 2, 1938	101
THE REMOTE CONTROL OVER POWER MAINS OF STREET LIGHTING, WATER HEATING, AND OTHER SERVICES	107
By E. M. S. McWhirter	
AN IMPROVED QUALITY COMMERCIAL TELEPHONE RECEIVER	116
By J. S. P. Robertson	
THE USE OF THE HIGH-VACUUM CATHODE-RAY TUBE FOR RECORDING HIGH-SPEED TRANSIENT PHENOMENA	124
By D. I. McGillewie	
A MUSEUM OF ELECTRONIC APPARATUS	133
By R. McV. Weston	
7-D ROTARY EXCHANGES IN RUMANIA	143
By Jacque ter Sarkisoff and L. B. Tucker	
TAKESABURO AKIYAMA	152
FUMIO SHIDA	153
A SIMPLE DIAL-OPERATED TELEPRINTER SWITCHBOARD	154
By Leslie B. Haigh	
APPLICATION OF SINGLE CHANNEL CARRIER TO EXISTING LOADED CABLES IN SWITZERLAND	157
By H. Jacot	
IRREGULARITIES IN TELEPHONE AND TELEVISION COAXIAL CABLES	164
By Leon Brillouin	
NOTES ON THE EFFECTS OF IRREGULARITIES IN COAXIAL CABLES ON TELE- VISION TRANSMISSION	188
By J. Saphores and P. Gloess	
1937 PARIS EXHIBITION AWARDS	194
TELEPHONE AND TELEGRAPH STATISTICS OF THE WORLD	195
RECENT TELECOMMUNICATION DEVELOPMENTS OF INTEREST	200



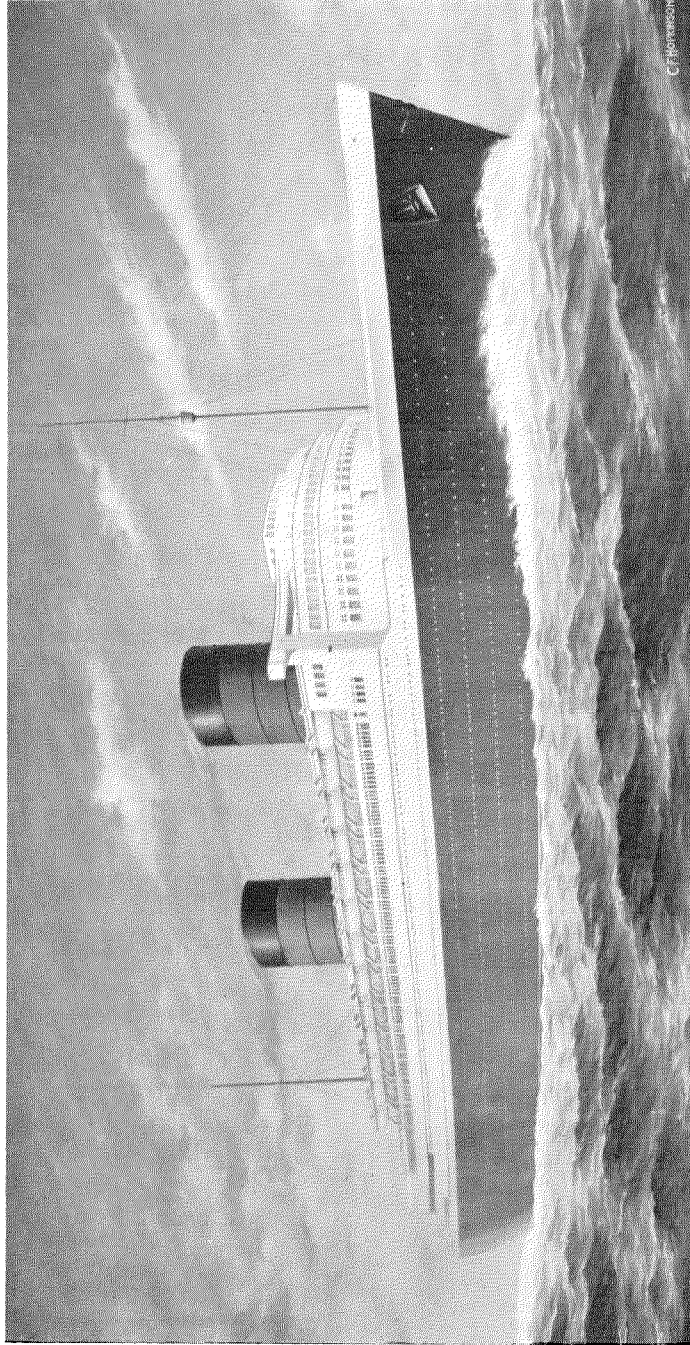

O.S.T.S. "Queen Elizabeth." On completion she will be the world's largest ship. As in the case of the "Queen Mary," her radio telegraph, radio telephone and associated equipments will be supplied and operated by the International Marine Radio Company, Ltd., London.

C.C.I.F. Meeting of Technical Commissions (1st to 5th incl.)

Oslo, June 20—July 2, 1938

THE five technical commissions of the C.C.I.F. met at Oslo from June 20th to July 2nd, 1938, to discuss and make recommendations concerning questions of Transmission and of Protection, placed in their hands by the XIth Plenary Assembly at Copenhagen in 1936.

Numerous questions of vital importance to the future development of international telephony came before the commission for discussion and decision, and this year's meeting may be said to have been particularly successful, especially in connection with the new carrier on cable technique and long distance toll dialling. Both of these phases of telephony are essentially international; great care in their development and application is therefore necessary to guard as far as possible against divergent trends in national systems. It was brought out in the discussions on these subjects that, whenever it is possible to arrive at an agreement on general methods and technique in the early development stage of such systems as are inherently international in scope, the C.C.I.F. should endeavour to do so, particularly since there are many features in the design of any new system where the choice of general method is more or less arbitrary. The very fact, too, that there may be no strong technical reasons dictating a specific course of action, on the one hand, increases the possibility of following divergent methods which would result in difficulties when international inter-connection becomes necessary; and, on the other hand, makes a universal agreement through the C.C.I.F. a comparatively easy matter *provided* the decision is taken early, i.e., before systems having divergent character-

istics have been established in the national systems of a number of countries. This function of the C.C.I.F. has always been more or less recognised, but the problems faced by the Oslo meeting brought it forcibly into the foreground.

A feature of the Oslo meeting which appears worthy of note was the tendency to turn over to smaller sub-committees of experts the discussion of technical details. This procedure not only facilitates a much more exhaustive study of technical details but also tends to speed up the formal work of the commissions. In certain cases these sub-committees were made semi-permanent and asked to continue their work by holding further meetings in the interval between commission meetings and the next Plenary Assembly, in order that recommendations on matters which could not be fully decided at the Oslo meeting but which were of vital interest in the general development of telephony, could be made to the next Plenary Meeting.

The work of the Oslo meeting and the major decisions arrived at are summarised below.

PROTECTION

The important matters discussed at the Oslo meeting concerned:

- (a) Revision of the "Directives" concerning the protection of telecommunication lines against the interfering effects of electric power systems;
- (b) Revision of the Recommendations concerning the measures to be taken for the protection of cables against electrolytic corrosion.

The new edition of the "Directives," which will be in force from January 1st, 1939, and

which will replace the present issue, dated 1930, was discussed and approved. This issue contains the latest recommendations concerning the protection of both telephone and telegraph lines, and outlines the precautions to be taken where telecommunication lines are exposed to high tension power or electric traction systems.

It also includes methods of calculating the interference under the various conditions encountered in practice and gives a specification for a psophometer which is recommended by the C.C.I.F. for the measurement of circuit noise and interfering effects from power equipment and high tension systems.

The "Recommendations" concerning protection of cables against electrolysis, approved by the 1st and 2nd C.R.'s, modify and amplify the previous recommendations appearing in Vol. II, bis, 1936. The new edition, which will be in force from January 1st, 1939, will be considered as guiding principles recommended to be followed by both electric traction and telephone interests in order to prevent damage to cable by electrolysis.

It contains details of protective measures applicable to both traction networks and underground cables for preventing electrolysis and recommendations for reducing stray electric currents in the earth. It also includes information on tests to be made on traction networks and cables in connection with electrolytic corrosion.

TRANSMISSION

a. Carrier on Cable

Carrier on Loaded Cables. Further advance was made in recommending essential characteristics of carrier systems on loaded cables; notably the following:

- (1) The frequency distortion for such circuits should be the same as that for 4-wire circuits and as given in diagram 2, page 153, Vol. I, bis, of the White Book.
- (2) The limit for the variation of equivalent with time of such circuits should be the same as that already established for international 4-wire circuits.
- (3) The relative level of any channel at the output of any repeater should not be greater than 9.5 db. or 1.1 neper. The

relative level at a frontier station (nominal value) should be 4.34 db. or 0.5 neper.

- (4) The overall crosstalk on such systems should meet the general values established for voice frequency international circuits.

Numerous other characteristics, both for the overall systems and the individual components (repeaters, loading coils, etc.), were generally agreed upon and, in certain cases, provisional limits were recommended.

Carrier on Non-loaded Cable Pairs. As a result of the decision arrived at during the first two days of the conference, relative to the desirable frequency band to be transmitted in international service, it was decided to recommend a frequency spacing of 4 000 p : s for new carrier systems on non-loaded cables, each channel to transmit a frequency band of 300 to 3 400 p : s. A group of 12 channels utilising the frequency band from 12 000 p : s to 60 000 cycles was recommended with virtual carrier frequencies of 12, 16, 20 . . . 56 kc, the *upper* side band to be transmitted. The carrier frequency must be stable to within ± 2 p : s.

Variation of equivalent with time for circuits obtained in this way should meet the general requirements already established for 4-wire circuits.

The "crosstalk difference" ("ecart diaphonique") for a repeater section terminated in its characteristic impedance should not be less than 69.5 db. or 8.0 nepers.

The method of measuring the harmonic distortion of an intermediate repeater was specified and a limit of 69.5 db. or 8.0 nepers recommended.

Unless otherwise specified, circuits obtained by carrier over non-loaded cables should meet the general requirements set down in the "Guiding Principles for the General European Switching Plan."

Coaxial Cables. It was not possible at the Oslo meeting to arrive at any general agreement on essential characteristics for systems utilising coaxial structures. In view of the pressing importance of avoiding as far as possible the divergent development of coaxial systems throughout Europe, a sub-committee was set up to study this question. It will meet in

London toward the end of 1938 in an attempt to arrive at an agreement on at least the general principles to be followed on such systems. This same sub-committee also will consider the basic principles of television transmission over coaxial structures.

b. Frequency Band to be Transmitted in International Service

One of the basic questions studied at the Oslo meeting was the question of the frequency band desirable in the future in international service. This subject has been under study for a number of years both as a question in itself, and as a part of the study of evaluating telephone performance (effective rating).

The decision of the Oslo meeting is expressed in the following recommendation :—

“The 3rd and 4th C.R.’s recommend :

that it is desirable to enlarge in the future the band of frequencies effectively transmitted in long distance communications ;

that this enlargement of frequency band be extended progressively to all types of circuits ;

that as a first step in meeting this general objective each channel obtained by carrier on non-loaded pairs in international cables transmit effectively the band of frequencies between 300 and 3400 p : s, corresponding to a spacing of carrier frequencies of 4 000 p : s.”

Methods to be employed to effect a widening of the band transmitted by other types of circuits was made the subject of a new question.

c. Long Distance Dialling

(1) For the purpose of the standardisation of ringing and busy tones, an agreement was reached on a recommendation covering the limits within which these tones should be constituted. The first step comprised the adoption of 400–450 p : s for all tones. To standardise on universal periods of interruption would have involved serious changes for many administrations ; however, a recommendation was made on the following lines :

- (i) The silent period of busy tone must not have a duration of less than 400 milliseconds. The duration of the tone and silent periods together must lie between 500 and 1 500 milliseconds.
- (ii) The tone period of the ringback tone may

be either continuous or interrupted, but it should have a duration of one second. The silent period must be equal to, or greater than, two seconds.

- (iii) It was recommended that the transmission of dialling tone should be abandoned on international circuits in the near future. Number unobtainable tone and a special toll busy tone were considered unnecessary for international circuits.

(2) A recommendation was made for the protection of national voice frequency signalling systems from interference from extraneous currents which might pass into the national system over international circuits. Owing to the difficulty of preventing short duration currents of these frequencies passing over the international circuits, and the fact that the duration of the signals, in part, is determined by the possibility of signal frequencies occurring in speech, it was recommended that provision should be made to prevent currents exceeding 400 milliseconds of either of the frequencies 600 or 750 p : s passing out to the international circuit. Similarly, currents exceeding 150 milliseconds of both frequencies in combination should be prevented. Currents of these frequencies of shorter duration should not result in incorrect signals.

(3) For signalling on international circuits, a directive was issued recommending the use of a prefix to all signals after selection has taken place. The prefix can be used to open the line in order to prevent voice frequency signals passing from end to end of a built-up connection when this is undesirable. The constitution of the fundamental signals recommended was :

Seizing signal	750 p : s suffix.
Dialled impulses	750 p : s pulses.
Answer signal	Prefix and 750 p : s suffix.
Clear back signal	Prefix and 600 p : s suffix.
	<i>Note: This signal is repeated as long as the condition persists.</i>
Forward release signal ..	Prefix and long 600 p : s suffix.
Backward release signal comprising :	
Clear forward signal	Prefix and 600 p : s suffix repeated until receipt of :
Release signal	Prefix and long 600 p : s suffix.
Duration of short suffix signal	60-100 milliseconds.
Duration of long suffix signal	300-400 milliseconds.

Duration of prefix ..	250-350 milliseconds of the two frequencies 600 and 750 p : s simultaneously.
Pause between prefix and suffix	30-50 milliseconds.
Pause between repeated signals	550 milliseconds minimum.

The limits of power, level and frequency to which the voice frequency receiver should respond were also specified.

A permanent sub-committee was appointed for the further study of long distance dialling. The specific questions placed before this sub-committee include :

- (1) Compound prefixes are considered probably more immune from speech interference than a single frequency prefix. Does the use of such compound prefixes complicate the receiver design ?
- (2) What precautions should be taken to prevent echo-suppressors disturbing voice frequency signalling ?
- (3) What measures are recommended to assure the receipt of signals such as the release signal on built-up circuits, especially those using intermediate and terminal echo-suppressors ?
- (4) What precautions are necessary to avoid interference to international voice frequency circuits from currents transmitted for national purposes only ?

d. Rating of Telephone Performance

Previous studies regarding methods of measuring and evaluating telephone performance of subsets, lines and the overall connection were continued. The studies come under three main headings :

- (1) Methods of comparing the performance and characteristics of subsets ;
- (2) Evaluating overall performance and the contribution made by each part of the connection (including the subset) to the performance of an overall connection under actual service conditions (effective rating) ;
- (3) The effect of line noise, room noise, cut-off, etc., on the overall connection under working conditions and the method of applying the data to actual design.

Considerable data have been gathered by various Administrations and are in the hands of the 4th Commission for study and analysis.

With regard to the question of evaluating performance, "effective rating" : the evaluating of performance by the amount of some observed quantity that includes all factors in actual service has been generally accepted, and there seems little doubt that "repetition rate" finds general approval as the best basic criterion for measuring effective performance. Due, however, to the difficulties and the almost prohibitive amount of work involved in obtaining repetition data on all possible combinations, studies are being made as to the possibility of utilising an articulation-volume relationship which will at least allow interpolation between various basic points obtained by the repetition method and which in itself may possibly lead to a workable method of evaluating effective performance.

A permanent sub-committee was established to keep in touch with this problem, in the interval between C.R. and Plenary meetings, to co-ordinate the work being done in the various Administrations, and to examine and analyse the various data obtained.

In connection with the study of subset characteristics, a study of loop impedances had been called for. After an examination of the data, the 4th C.R. concluded that the range of impedances encountered in practice was too wide to permit specifying a typical condition for tests of side tone. In the future, Administrations requiring measurements of side tone in the SFERT laboratory must specify the various line impedances with which they wish the measurements made.

e. Other Miscellaneous Studies

Crosstalk. The Oslo meeting proposed changing the present recommendation regarding crosstalk to read as follows :—

" The 3rd Commission recommends :

- (1) *that the limit for both the near-end and far-end crosstalk between two complete circuits in the same cable in the terminal condition (overall equivalent equal to 0.8 neper for 4-wire circuits and 1.0 neper for 2-wire circuits) shall, provisionally, be not less than 7.5 nepers or 65.1 db. for 90 per cent. of the possible combinations, and 6.8 nepers or 59 db. for 100 per cent. of the possible combinations ;*

(2) *that this question be maintained for further study.*"

Certain suggestions were made regarding apparatus to be used for the objective measurement of crosstalk.

Noise. A certain amount of data was presented relative to noise on international circuits, and these data and the variable nature of the line noise were discussed. A recommendation was then made to recognise a steady component having a limit determined by a formula expressing noise voltage as a function of line lengths and a permissible occasional maximum value governed by a similar formula. It was recommended that, if the European Toll Plan Committee need to take noise into account in their studies, the table on page 93 of Volume I, bis, of the White Book be used provisionally. This table gives the noise transmission impairment resulting from various values of line noise.

Impedance of International Circuits. The normal impedance of international circuits was formerly fixed at 800 ohms with upper and lower limits of 600 ohms and 950 ohms, respectively. The Oslo meeting, although maintaining the upper and lower values of 600 ohms and 950 ohms, recommended that, in future, attempts should be made to maintain, as far as possible, the value of 600 ohms for the impedance of an international circuit as measured from its terminals (including the terminal transformer).

Radio-Broadcast Programme Transmission. Numerous problems involved in the transmission of radio-broadcast programmes were discussed with representatives of the U.I.R. The 3rd, 4th and 5th C.R.'s proposed a modification of the present recommendation concerning the coefficient of harmonic distortion. The new proposals fix the coefficient of harmonic distortion for broadcast repeaters at not greater than 1 per cent. within the frequency band from 100 p : s to 8 000 p : s ; in the frequency band from 100 p : s to 30 p : s, it may be allowed to reach 4 per cent. For an overall circuit of 1 000 km, the corresponding limits are 5 per cent. and 15 per cent., respectively, but attempts should be made to keep them, wherever possible, within 4 per cent. and 10 per cent. maximum, respectively. The gain of a broadcast repeater should not vary more than 0.05 neper in the frequency band between 30 p : s and 600 p : s,

or more than 0.1 neper for the higher frequencies when the output voltage varies from 0.775 volts to 4.0 volts. The corresponding limits for an overall circuit of 1 000 km are 1.0 neper for the low frequencies and 0.2 neper for the higher frequencies.

Numerous questions concerning the maintenance of radio-broadcast circuits, methods of making routine tests, frequencies to be used in testing, etc., were discussed and recommendations made by the Permanent Sub-committee for Maintenance.

f. The General European Toll Switching Plan

Considerable work has been done by the Mixed Commission charged with the study of a General European Toll Switching Plan, notably at its 1937 Paris meeting. During the Oslo meeting the technical members of this commission met to review the recommendations of the previous Paris meeting. These recommendations were then presented to the 3rd and 4th C.R.'s in a document entitled, "Guiding Principles for the Establishment of a General Toll Switching Plan for Europe." These guiding principles reflect the decisions arrived at in the 3rd and 4th C.R.'s on specific characteristics which overall circuits and connections should meet in actual operation in the European international network. These guiding principles, as approved by the 3rd and 4th C.R.'s, propose a "typical limiting international connection" and give a classification of switching centres and of circuits in accordance with the part such circuits play in such an overall connection.

The following values were recommended for the working equivalents of the European long distance network :

(1) Maximum allowable working equivalent for the limiting international connection	4.6 nepers
(2) Limiting equivalent for the national transmitting system	2.35 nepers
(3) Limiting equivalent for the national receiving system	1.85 neper
(4) Maximum allowable working equivalent for the chain of international circuits interconnecting the two terminal international switching centres	0.4 neper

The nominal value of an international circuit in the transit condition is zero. The above value of 0.4 neper takes into account the

possible variation of ± 0.1 neper in the working equivalent of the international circuit from the nominal value of 0.0 neper, and also the variation of the equivalent of the overall chain of international circuits with time. A new question was proposed for further study to determine whether the 2.35 neper and the 1.85 neper limits for the national transmitting and receiving systems should include similar variations.

A tentative echo curve for circuits equipped with echo suppressors was adopted for the use of the mixed commission in its investigations, and a new question was placed on the agenda covering the adoption of a final echo curve to be used as a future design limit. The "directives" give details of the method of calculating the minimum net working loss of circuits from the standpoint of echo effects and stability. A new question also was proposed regarding the possible effect of crosstalk in determining the minimum working equivalent of long distance circuits.

Definitions regarding characteristics and functioning of echo suppressors were enlarged and made more specific, and additional questions regarding such equipment were placed on the agenda for further study.

In considering limits for national transmitting

and receiving losses, the question of bringing all data regarding the performance contribution of the subsets to the overall limit was discussed. Further data was asked for from all Administrations.

The "Guiding Principles" finally adopted provide a general guide for long-distance network design and for determining whether a given routing meets present transmission performance requirements. The work of the Mixed Commission is to be continued; and, as new data becomes available and new recommendations on specific questions are made by the 3rd and 4th C.R.'s, the "Guiding Principles" will be revised and enlarged.

APPLICATION OF NEW RECOMMENDATIONS ON URGENT QUESTIONS

In accordance with the decision taken at the XIth Plenary Assembly at Cairo (1938), the recommendations made by the Oslo meeting on questions relating to Protection, Carrier-on-cable, the General European Toll Switching Plan and Long Distance Toll Dialling will be circulated to all Administrations adherent to the C.C.I.F. and, if generally acceptable without major changes, will be considered as being in force without waiting for approval by the next Plenary Assembly.

Bruce H. McCurdy.

The Remote Control over Power Mains of Street Lighting, Water Heating and other Services

By E. M. S. McWHIRTER, A.C.G.I., A.M.I.E.E.,

Standard Telephones and Cables, Limited, London, England

PUBLIC lighting is a fairly modern service which has grown up largely as a result of increasing road traffic. In olden times it was considered that the public authority had met its obligation when it permitted link boys to be hired by people who could afford it and wanted the protection of light whilst they traversed the dark streets. Oil lamps in the more busy thoroughfares, to be succeeded by gas lamps, provided the first true public lighting.

Electricity for public lighting was probably first used in the form of arc lamps, but because of the necessity of replacing carbons and readjusting them, they were both expensive and somewhat unreliable in the early days. Vacuum filament lamps, succeeded by gas filled lamps, and in recent years, by discharge lamps, have improved and reduced the cost of street lighting to such a point that, on a well lighted, modern road, there is now little reason for driving a motor vehicle at a slower speed during the night than in daylight.

It may be interesting to note, incidentally, that modern discharge lighting is approximately twenty-five times more efficient than the lighting of forty years ago as regards the amount of electricity consumed to provide the same amount of light. If this be considered along with an average reduction of 50 per cent. in the

price of electricity for lighting purposes, the astonishing fact becomes apparent that the equivalent of modern electric lighting would have cost fifty times as much at the beginning of this century.

Concurrently with the development of street lighting, means for controlling this service have been devised. From the early days when the lamp lighter made his round twice in twenty-four hours, progress has been made through stages of time switch control, first of all by ordinary clock mechanisms which had to be wound every few days, and then by electrically driven time switches to the latest development of centralised control by means of signals transmitted over the power

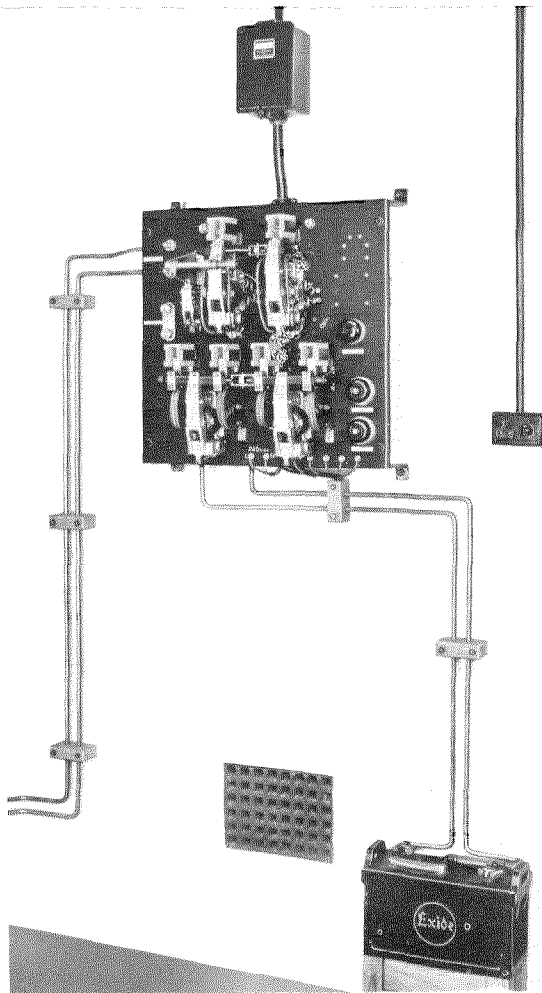

Fig. 1—Substation Biasing Panel and Battery.

network supplying the electrical energy to the community generally.

In the past, power for street lighting was supplied largely by means of cables separate from those which served the ordinary consumers. Thus, it was possible to utilise separate switches in the substation, and control the street lighting from one point in each district. This method, although very successful in operation, is obviously expensive in cable cost, particularly when it is considered that street lighting is most commonly carried out by means of posts set alternately on each side of a street.

As early as 1913, endeavours were made to provide a means for signalling by a high frequency alternating current introduced into a network at the supply point. The earliest attempts were unfortunate in that they occurred just before the Great War, but recently similar systems have again found their way into the market. Again, they are handicapped by high initial expenditure since, with the growth in size of the electricity undertaking, the size of the high frequency generator must be correspondingly increased.

Standard Telephones and Cables, Limited, London, considered the problems of remotely controlling street lighting some six or seven years ago and, like so many others, turned their attention first to ways and means for using a high frequency system of A.C. signalling. Many ingenious schemes were proposed, but, in almost every case, upon examination of costs, it was evident that the right solution, which

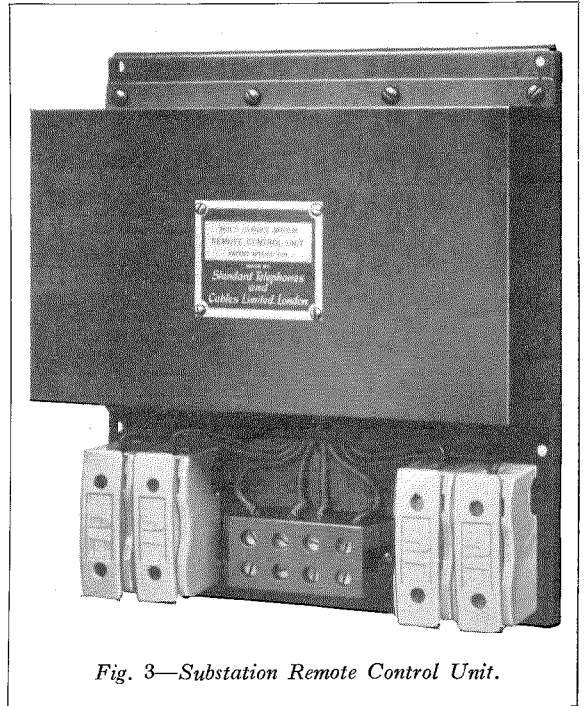

Fig. 3—Substation Remote Control Unit.

would compare favourably in cost with the synchronously wound time switch, had not yet been found. Furthermore, it did not appear reasonable that prospective users would be interested in a system which would necessitate discarding all existing time switches or other means of street lighting control.

This consideration prompted the suggestion that a considerably cheaper method, involving the application of a low voltage D.C. bias to the network, might be adopted rather than

a prohibitively expensive scheme depending on the utilisation of a high frequency alternating current. With the development of a ready means of separating the A.C. from the D.C. at the receiving lamp post points, the S.T.C.-D.C. Bias System of Street Lighting Control came into being.

This D.C. bias

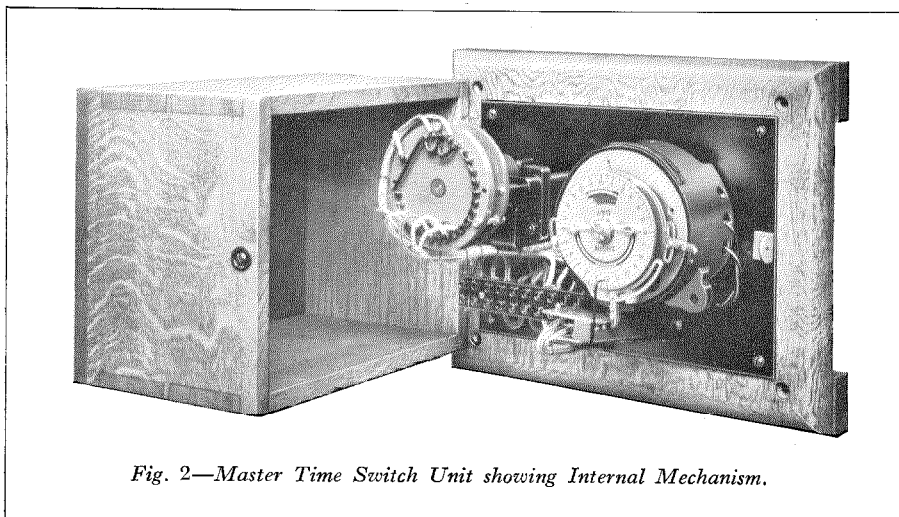

Fig. 2—Master Time Switch Unit showing Internal Mechanism.

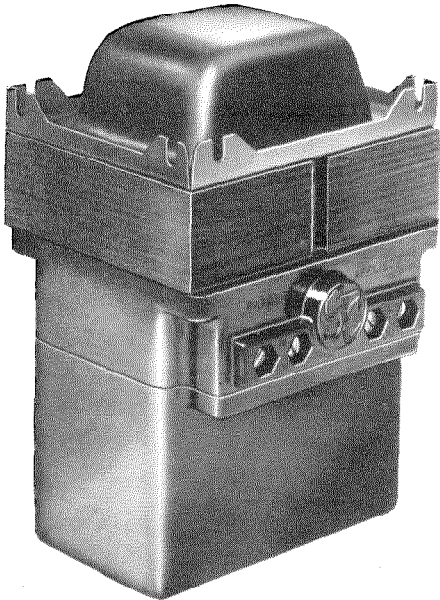

Fig. 4—Lighting Unit in Moulded Case.

Inductive or any heavy machine loads are almost entirely 3-phase delta connected and, therefore, do not connect between phase line and neutral. Consequently, D.C. applied between the phase lines and neutral will not be shunted by such loads.

Almost every modern A.C. network conforms to this general condition. It has thus been possible to design a system whereby the application of a 6-volt heavy capacity battery between the star point and neutral of the low tension side of a distribution transformer will transmit 6 volts with approximately the above percentage drop to the remotest part of the feeder cables connected to the transformer bus-bars.

With this fundamental principle, it is evident that a ready method of transmitting signals from each substation to any part of the network is obtainable—a method that is at once low in

system has the very great advantage that it can be applied in the first instance locally to particular districts of a network and, as other methods or equipment in use elsewhere become due for replacement, it can be extended until the whole of the street lighting of a town is controlled from one point.

PRINCIPLE OF OPERATION OF D.C. BIAS SYSTEM

If a D.C. bias be superimposed on an A.C. circuit, this bias will extend to all parts of the circuit directly connected to the point at which the D.C. bias is applied, but will not affect those parts of the circuit which are magnetically coupled, e.g., the transformers. It is also a fact that the network can be treated separately for the application of D.C., just as though the A.C. energy were not present; moreover, for purely non-inductive loads, the percentage voltage drop obtainable with A.C. and D.C. will be substantially the same. This means that if a network has a load which is almost entirely domestic with a percentage drop not exceeding 4 per cent., then, with a 6-volt D.C. source of energy applied to the same network, the voltage drop will not be greater than 4 per cent. of 6 volts or .24 of a volt.

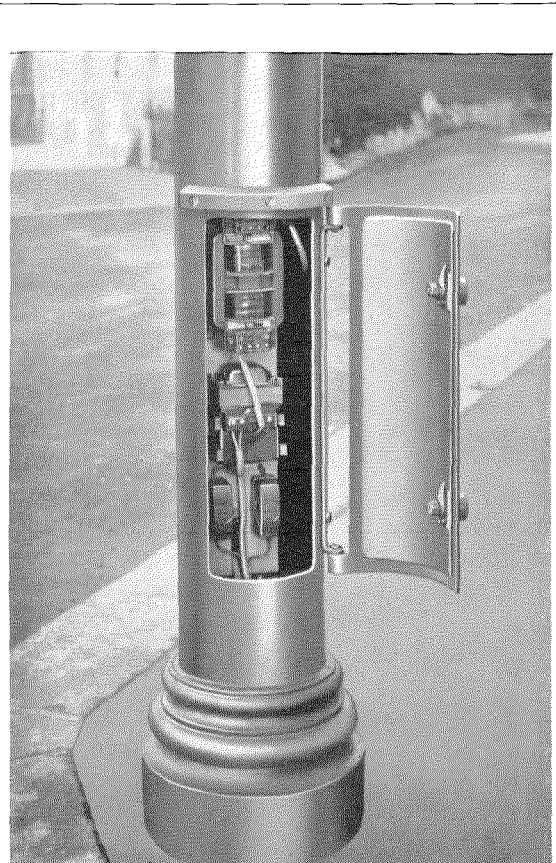

Fig. 5—Lighting Unit mounted in Base of Street Post.



Fig. 6—Multi-service Unit.

initial cost, thoroughly reliable, simple and robust in its application, and free from interference to any sensitive apparatus, such as radio sets, etc., connected to the network.

Reception of the Impulses

With a D.C. bias of 6 volts applied between the phase lines and neutral it is possible by means of a specially designed transformer type of choke, arranged so that the voltage induced in the secondary is exactly equal and opposite to the mains A.C. voltage applied to it, for a relay to respond only to this D.C. bias and to remain unaffected by the alternating current. This applies even when the voltage employed for the D.C. bias is one volt or less, while the A.C. voltages are of the order of 200–240 phase to neutral. By using 6 volts as the energising bias and relays that will operate at 4 volts, ample margin of safety for positive operation is assured. The A.C. current consumption of such an arrangement is a minimum, the current value through the relay being less than one milliamperes A.C., and about twenty milliamperes D.C. when a bias impulse is applied.

Half-Night Lighting Control

Two distinct and separate signals can easily be obtained by single impulses from such an arrangement, depending on whether the 6-volt battery is connected with its positive terminal to the star point and its negative terminal to the neutral, or vice versa. Thus, by using polarised receiving relays, a simple method of sending an “on” and an “off” signal is available for the control of half-night lighting.

All-Night Lighting Control

A simple “on” and “off” service, however, is not all that is required for street lighting control. Some lights must be left on all night, while others are required to be switched off at midnight. Thus, although one short positive pulse can be used to switch on all the lights, two different pulses are necessary for switching off, in order to differentiate between the half-night and all-night lights. This has been achieved by using a short negative pulse (2 seconds’ duration) for the half-night switching off service, while a longer negative pulse (20 seconds’ duration) switches off the all-night lights, the relays controlling the latter being fitted with a delay action. By using this delay action relay, three distinctly separate signals are obtained with the simplest arrangement of polarised receiving relays.

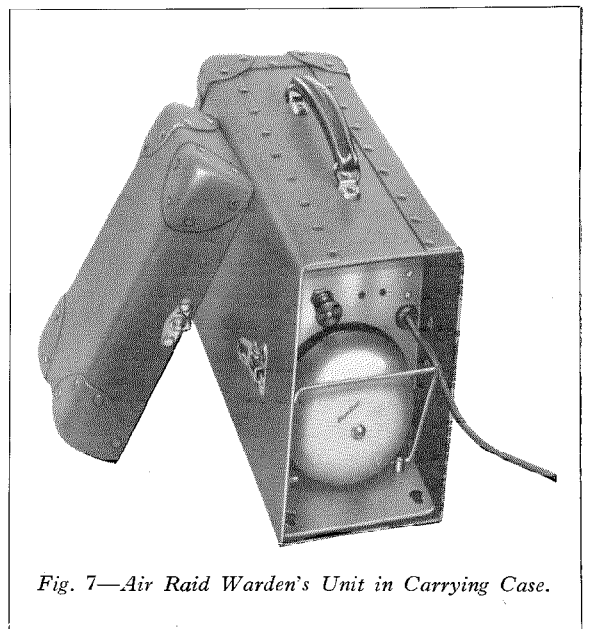

Fig. 7—Air Raid Warden's Unit in Carrying Case.

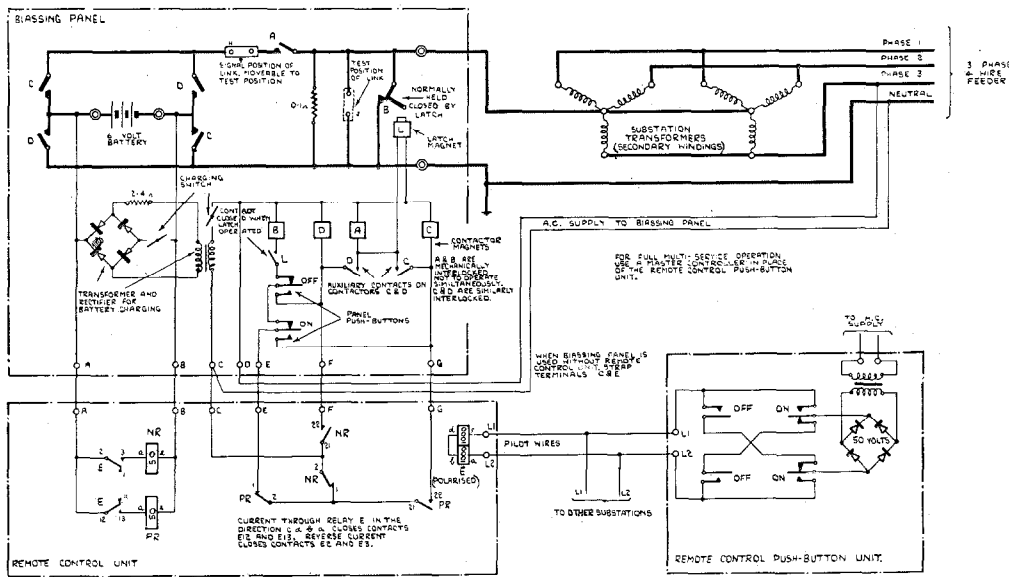

Fig. 8—Schematic Circuit of Substation Biasing Panel with Remote Control.

Additional Services

Equally with the growth of public lighting, the past decade has seen an almost phenomenal increase in the general consumption of electricity. Unfortunately for those who control the generation and distribution of electrical energy, much of the consumers' load occurs within limited periods of the twenty-four hours with the result that the problem arises of supplying plant and cables which are capable of carrying heavy peak loads for a few hours and which are only lightly loaded for the remainder of the twenty-four hours. Consequently, many distribution authorities have considered the problem of supplying energy at cheaper rates during the periods of light load, and one type of load which could readily be catered for is heating water for domestic and industrial purposes. Provided these water heaters could be cut off during the peak load of the rest of the system, they would provide an extremely useful function in filling up the valleys in the load curve.

With air raid precaution schemes, other uses for a means of signalling over the mains became apparent, involving the control of air

raid sirens, and the calling out of volunteer firemen and of volunteer wardens.

An extension of the D.C. bias impulse system to cover these services was, therefore, designed with the following underlying requirement: it should be possible to install a street lighting equipment initially and to add these additional services if and when they were considered necessary without in any way affecting the street lighting control equipment.

TYPE OF EQUIPMENT

The Biasing Unit

Since a D.C. impulse cannot be transmitted through transformers, it is necessary for each substation to be equipped with a biasing unit, the essentials of which comprise a contactor panel and a 6-volt heavy duty battery. It is the function of the contactor panel:

- (a) To maintain normally a continuous connection between the star point of the transformer or transformers in the substation and the neutral conductor;
- (b) To introduce the 6-volt battery, in one direction or the other, into this circuit for the time of sending an impulse.

Fig. 1 illustrates a biasing panel mounted on the wall and connected to the 6-volt battery.

Each panel is complete with a very heavy duty resistance of 0.1 ohms which, connected solidly across the latched-in contactor normally connecting star point to neutral, serves to prevent this circuit from being opened for the brief interval of about one cycle (approximately twenty milliseconds), whilst the latched-in contactor opens and the battery contactor closes the circuit.

Each panel is equipped with push buttons labelled "on" and "off." With these push buttons and an ordinary watch with a seconds hand, any signal either for street lighting control or for multi-service can be transmitted over the network supplied by the substation.

This important feature is always available for emergency use.

Each panel is equipped with a link which, when placed in the "test" position, renders the panel inoperative for transmitting signals over the network. The link itself, however, serves to maintain the closed circuit between star point and neutral whilst the contactors are tested and maintained. When the link is returned to the "signal" position, the panel is again in service and ready to transmit signals.

Master Time Switch Unit

Equipments that are only required in the first instance for the control of street lighting, can be supplied with a Master Time Switch Unit suitable for connecting directly to the biasing panel and arranged so that the correct impulses (short positive for "lamps on," short negative for "half night lamps off," and long negative for "all night lamps off"), are automatically transmitted at the correct times under the control of a solar dial master time switch.

A wall mounting case houses the master time switch, which is specially arranged to give short make contacts for each of the three switching times, and also a second synchronously driven timing switch which is connected to control the right type of pulse for the required length of time. The master time switch, therefore, controls the timing switch which, in turn, directly controls the biasing panel without the introduction of any other relays.

Both the master switch and the timing switch are synchronously driven and require no maintenance other than that normally given to the more usual type of time switch.

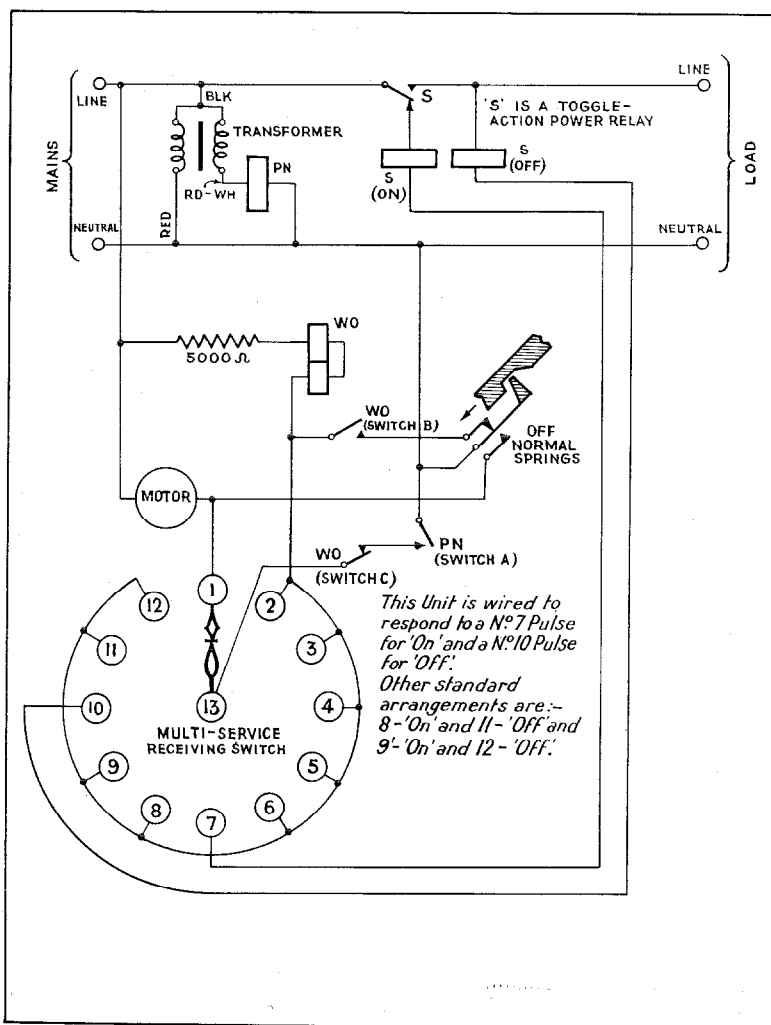

Fig. 9—Schematic Circuit of Multi-service Control Receiving Unit.

Fig. 2 illustrates the Master Time Switch Unit mounted in a case ready for mounting on the substation wall.

One Master Time Switch Unit Controlling a Number of Substations

In those cases where a number of substations are to be controlled from one point, the Master Time Switch can be used in conjunction with a Substation Remote Control Unit to control any number of substations connected to the master station by an ordinary pilot wire or telephone circuit.

Substation Remote Control Unit

This unit is designed to receive two different pulses, over a pair of telephone wires, transmitted from the central control station and thereby causes the biasing panel in the substation to send out either a positive or a negative bias impulse.

A simple arrangement of steel panel and cover, enclosing the relays for receiving the impulses over the pilot wires and for operating the bias panel, constitutes the unit which is complete with fuses and terminals and suitable for wall mounting. Fig. 3 illustrates this unit.

System for a Typical A.C. Network

A typical A.C. network would probably comprise a number of transformer substations interconnected by means of high tension cables fed from the generating station or bulk supply point. Each substation might be equipped with one, two or more transformers stepping down from the H.T. to the L.T. distribution voltage and feeding out by means of the street mains to the consumers a supply of electricity on a three-phase four-wire distribution system.

At each of these substations and connected to the L.T. supply of the transformers, a biasing unit would be required in order to

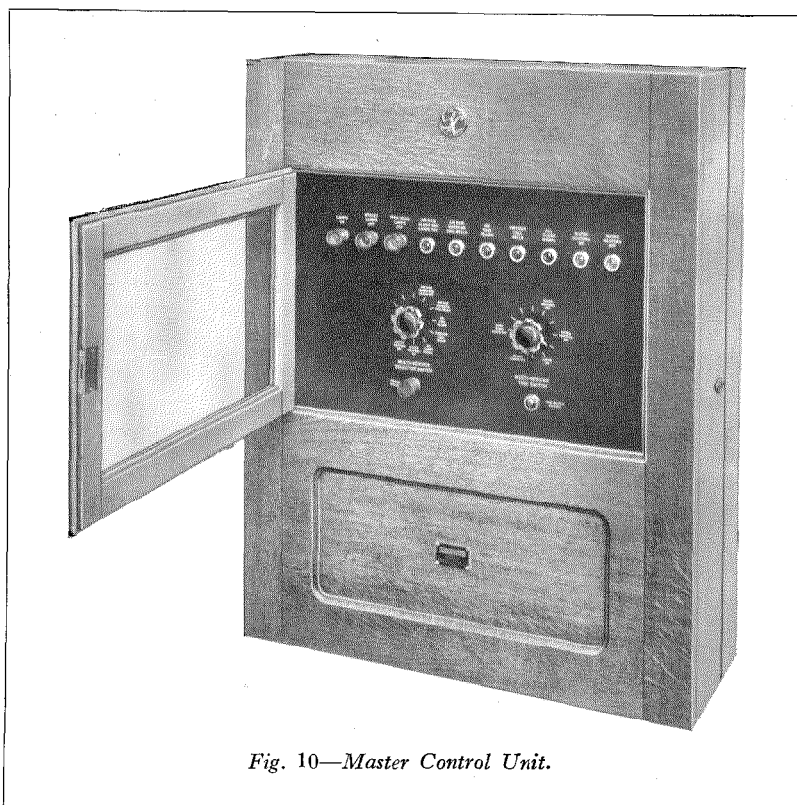

Fig. 10—Master Control Unit.

apply the 6-volt D.C. bias to the cables supplied from the substation. The bulk supply or generating station, which might well be the control point, would be equipped with a master control unit or, where street lighting only is involved at first, with a master time switch and push button unit. By means of a pair of pilot wires from this station to each of the supply substations, impulses are transmitted to a small relay remote control unit, thereby causing the biasing unit in the substation to be operated from the control of the central station.

At each point in the area at which the biasing signals are to be received, a unit is fitted suitable for the service required: for street lighting, a simple unit consisting of the transformer and relay in a case of moulded plastic material would be mounted on each lamp post as shown in Figs. 4 and 5; whilst, for each water heating consumer, a multi-service unit would be fitted as shown in Fig. 6. For the calling of volunteers, a unit is available for wall mounting or for carrying in a portable case. Such a unit is illustrated in Fig. 7.

The circuit arrangement of this equipment

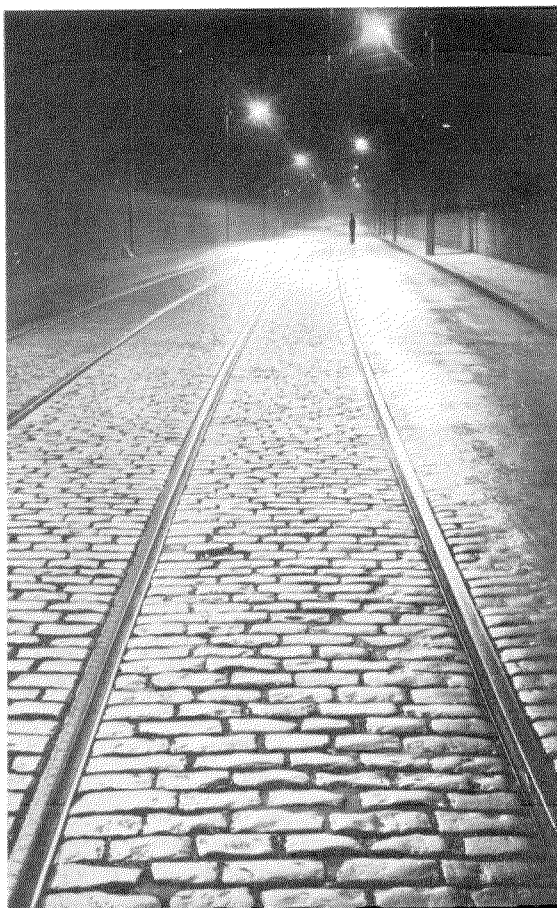

Fig. 11—Section of New Lighting at Bingley—reproduced from photograph taken August 15th, 1938.

is shown in its simplest form in Fig. 8, whilst Fig. 9 illustrates that of the multi-service receiving unit.

The biasing unit, consisting of an arrangement of contactors as shown diagrammatically in Fig. 8 and illustrated in Fig. 1, is a simple wall mounting contactor panel with a 6-volt heavy duty car battery. The panel is complete with a trickle charger and is also equipped with emergency push buttons for sending either a positive or negative signal.

Should a network comprise only one sub-station, which is to be left unattended, this biasing panel can be controlled directly from a master time switch unit (Fig. 2), which can be mounted on the wall beside the biasing panel.

Alternatively, where remote control of the biasing unit from a central point is required,

a substation remote control unit, illustrated in Fig. 3, is supplied. At the control station, the master control unit (Fig. 10) then supplies the necessary impulses over the pilot wires to all sub-stations for the operation of the remote control units.

APPLICATIONS

Electricity supply authorities have shown very considerable interest in the D.C. bias system. Many authorities have decided either to adopt it or are giving it a trial in order to determine its suitability for their purposes.

The City of Lichfield was the first to adopt it for the control of its lighting and other services; and the City Engineer, with the co-operation of the authorities, gave a demonstration of the use of the system for the control of street lighting, the operation of air raid alarms, and the calling out of volunteer firemen and air raid wardens, on the night of March 8th, to some two hundred engineers from other authorities from all parts of Great Britain. Lack of space makes it impracticable to describe fully in this article the complete success of the demonstration, but the programme of the demonstration (Table I) illustrates the great value of the system in connection with these services.

One of the other earliest authorities to introduce the system into its network was the Borough of Hornsey, which has now decided to control the whole of its three thousand lights by means of this system.

At the Convention of the Incorporated Municipal Electrical Association held at Torquay in May, 1938, the system was demonstrated by means of a large display panel thirty feet in length. It included forty street lamps, firemen's houses and air raid wardens' houses as well as two water heating control points, represented by ordinary tubular heaters arranged in a painted lay-out of a typical town. Demonstrations of the firemen's and wardens' calling units were given by ringing the bells of the houses in the panel. The whole effect created very considerable interest amongst the visiting engineers, inasmuch as it gave an excellent pictorial representation of the possibilities of the system.

In conclusion, it is of interest to mention

that the town of Bingley, which has recently adopted the system, is utilising it to control three and a half miles of main road lighting, consisting of the very latest type of discharge lamp corrected for colour. The inauguration of the equipment took place on August 15th,

when it was first switched on from a remote point by the chairman of the Council. One hundred and forty 400-watt discharge lamps are included in this lighting scheme; the effect of the lighting is well illustrated in Fig. 11, which is reproduced from a photograph taken at 2 a.m.

TABLE I

10.00 p.m.	Visitors assemble in the Guildhall.	11.15 p.m.	SECOND RAID WARNING RECEIVED.
10.30	NORMAL STREET LIGHTING IS REDUCED TO WAR TIME CONDITIONS. Since the permissible lighting has not yet been determined, the all-night lighting is being used in this demonstration as representing these conditions.	11.15	Planes estimated to be 50 miles away and travelling towards Lichfield.
10.35	ADDRESS BY HIS WORSHIP THE MAYOR OF LICHFIELD.	11.15	AIR RAID ALARM PUSH BUTTONS OPERATED. Fifteen sirens, controlled at six points, are sounded simultaneously for 45 seconds.
10.45	BRIEF DESCRIPTION OF THE SIGNALLING SYSTEM. The following facilities will be controlled from the Guildhall by Push Buttons transmitting signals over all the low tension service mains of the City :	11.18	ALL LIGHTING EXTINGUISHED. Signal is transmitted over the service mains to operate relays at each lamp switching point.
	<ol style="list-style-type: none"> 1. Switching Emergency Lighting "off" and "on." 2. Calling Volunteer Firemen from their homes. 3. Calling Volunteer Wardens from their homes. 4. Sounding Sirens at six points in the City for Alarm and All Clear Signals. 	11.19	BLACK - OUT .
11.00	FIRST WARNING OF ATTACK RECEIVED. Planes estimated to be 100 miles away.	11.25	FIRE BRIGADE TURN OUT. Vehicle lights are shrouded to minimum.
11.00	VOLUNTEER FIREMEN CALLED OUT. An Alarm Bell, connected to the ordinary service mains in each man's house, is operated by a signal transmitted over the mains.	11.30	AMBULANCE TURN OUT. Vehicle lights are shrouded to minimum.
11.01	VOLUNTEER WARDENS CALLED OUT. Each Warden is equipped with a portable Call Bell Receiver which he plugs into the mains wherever he is located.	11.35	ALL CLEAR SIGNAL RECEIVED.
11.02 to 11.10	Reports received from Wardens and Firemen reporting for duty at their various stations.	11.35	ALL CLEAR PUSH BUTTONS OPERATED. Fifteen pairs of sirens, controlled at six points, operate to give a two-note signal repeated eight times.
		11.40	Fire Brigade and Ambulance Return.
		11.45	Attackers Reported Returning.
		11.45	LIGHTS OUT AND ALARM SIREN OPERATED FROM ONE PUSH BUTTON. BLACK - OUT IN 30 SECONDS.
		11.50	Fire Brigade Turn Out.
		11.59	Final All Clear Sounded.
		12.00	All-night Lighting Restored.

An Improved Quality Commercial Telephone Receiver

By J. S. P. ROBERTON, B.Sc.,

Standard Telephones and Cables, Limited, London, England

INTRODUCTION

SUBSCRIBERS' telephone instruments have changed remarkably little since the early days of telephony, particularly in the case of the receiver, the essential construction of which, until quite recently, has substantially resembled that of the first electromagnetic receiver invented by Alexander Graham Bell. From time to time improvements in efficiency were effected but, because receivers have been judged by their volume efficiency as determined by voice-ear tests, the tendency in receiver design has been towards one giving maximum output under such testing methods. Voice-ear tests employ a transmission system of which the overall efficiency depends on the output of the voice and the sensitivity of the ear; the maximum efficiency of such a system occurs at a frequency of about 800 p.s. Consequently, the fundamental diaphragm resonance of receivers has usually been at or near this frequency. Attempts to obtain a more uniform receiver response have invariably been made at the expense of volume efficiency; moreover, such improvements could, in the past, be judged only by personal impressions. For these reasons, little improvement in receiver quality has hitherto been achieved.

Three factors, in the past few years, have resulted in considerable improvement in the performance of the ordinary commercial telephone receiver. First, replacement of voice-ear methods of testing receivers by new methods which take account of their frequency response, namely, articulation tests⁽¹⁾ and repetition rate tests⁽²⁾ for judging the effectiveness of a circuit or a piece of apparatus. Secondly, the introduction of the artificial ear coupler,⁽³⁾ replacing the human ear for testing purposes, has made possible more exact and more rapid analyses

of receiver frequency response characteristics. Thirdly, new magnetic materials⁽⁴⁾ with considerably improved properties have recently become available. It has thus become possible to maintain the general response level of the receiver whilst introducing damping in order to secure a more uniform frequency response characteristic.

Improvements in the quality and efficiency of receivers have recently been introduced in the United States,⁽⁵⁾ (14) Germany⁽⁶⁾ and Japan.⁽⁷⁾ Studies aiming at the same result were commenced some years ago by the International Telephone and Telegraph Laboratories, Incorporated, and continued by Standard Telephones and Cables, Limited. The British Post Office has kept well abreast of such developments, and West and McMillan of the British Post Office Research Station carried out preliminary work aiming at improving both the operators' and the hand-set receiver.⁽⁸⁾ The present article describes a new hand-set receiver, and also a new head receiver following similar principles; they were developed for the British Post Office by Standard Telephones and Cables, Limited, in conjunction with the British Post Office Research Station.*

The new receivers have been coded as follows:—

	<i>S.T. & C. Code.</i>	<i>B.P.O. Code.</i>
Hand-set Receiver	4027 Receiver	Receiver Inset 2-P
Single Unit Head-set	4028 Receiver	Receiver Headgear 10-A Mark 2
Double Unit Head-set	4029 Receiver	—
Watch Type Receiver	4030 Receiver	—

* A paper entitled "Some Recent Developments in Subscribers' Telephone Apparatus," which included reference to Receiver Inset 2-P, was read before the Institution of Post Office Electrical Engineers by C. A. R. Pearce of the Post Office Engineering Department on 8th March, 1938.

⁽¹⁾ For numbered references see end of article.

PERFORMANCE OF THE NEW RECEIVER

Fig. 1 (curves A and B, respectively), shows the frequency response characteristic of the new hand-set receiver and of the new head receiver, whilst Fig. 1 (curve C) represents the characteristic—typical of the older type of receivers—of the British Post Office hand-set receiver No. 1-L. The latter will gradually be replaced by the new type of receiver. All these curves were measured with the receivers coupled to the measuring apparatus through the medium of an artificial ear,⁽³⁾ the acoustical properties of which approximate those of a typical human ear. It will be noted that curves A and B are not only very much flatter than curve C, but the output over the region of 1 500–3 000 p:s has been raised some 10-15 db. above that of the old receiver. This increased efficiency over the upper part of the commercial voice frequency range is one factor which is responsible for the improved performance of the new receiver. Another factor, which is also important, is related to the phenomenon known as "masking." It has been shown by R. L. Wegel and C. E. Lane⁽⁹⁾ that, when sound waves consisting of more than one frequency are impinging on the ear, strong tones of one frequency will mask or

render inaudible tones of other frequencies, more especially frequencies higher than that of the masking tone, provided that the intensity difference between the masking and the masked tones is sufficiently great. Thus, in the older receivers, the frequencies around the diaphragm resonance are so powerfully reinforced as to cause some masking of other frequencies which are reproduced relatively weakly. In the new receiver, however, the absence of any pronounced resonance largely eliminates this masking effect, with a corresponding gain in intelligibility.

The volume efficiency of the new receivers, as judged by voice-ear tests, is approximately equal to that of Receiver Inset No. 1-L, or approximately 2.5 db. better than the No. 144 Receiver Standard measured in the Standard Test Circuit. However, as judged by various subjective tests, including articulation tests, carried out in the laboratory, the new receivers are from 0 to 10 db. better in effective rating than the old receivers, the amount of the improvement depending on the type of circuit and the conditions of room noise, circuit noise, amount of side-tone, etc.*

* These tests were carried out by W. West of the Post Office Engineering Department Research Section.

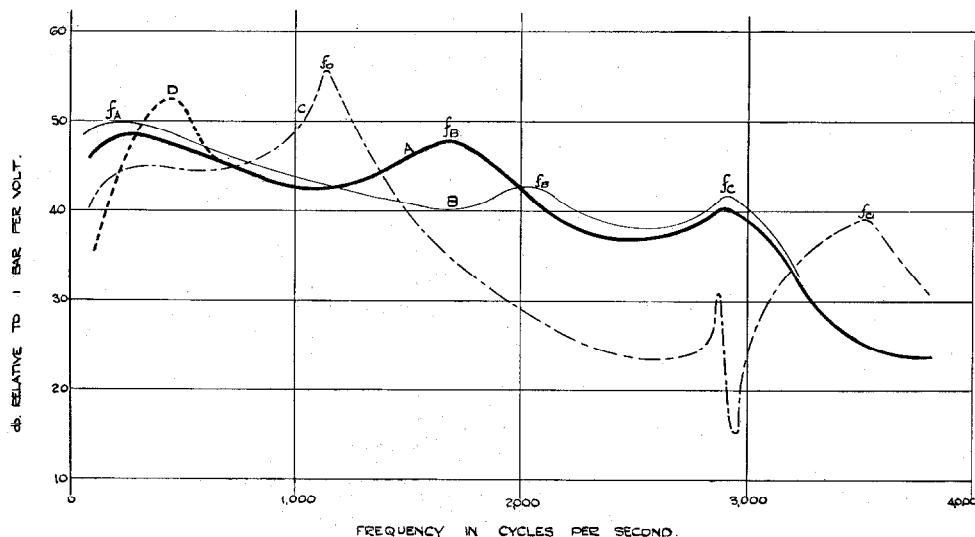

A - RECEIVER INSET 2-P. B - HEAD RECEIVER 10A/2. C - RECEIVER INSET 1-L. D - SHOWING EFFECT OF A LEAK BETWEEN EARCAP AND EAR.

Fig. 1—Frequency Response Characteristic of the New Receivers (Curves A & B) and of the B.P.O. Hand-set Receiver No. 1-L (Curve C).

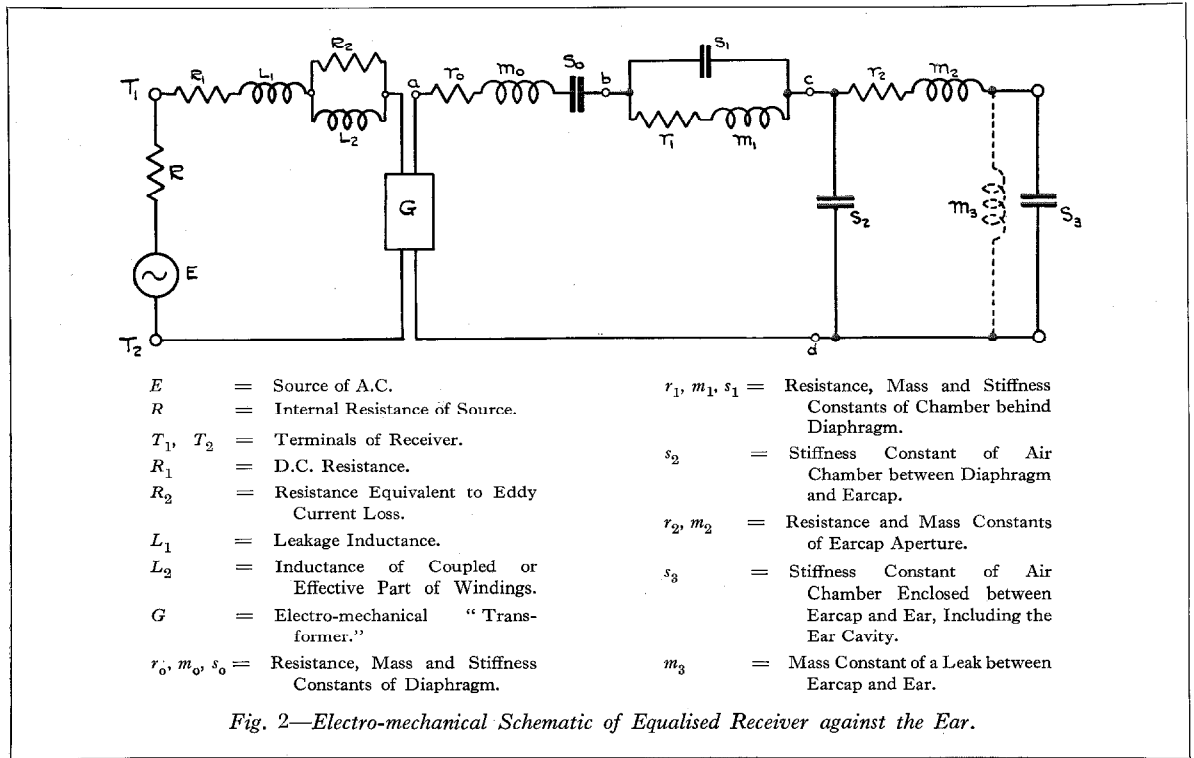

An advantage of the new receiver, due to its damped characteristic, is that the effect on the ear of surges or any abrupt interfering noises in the listener's circuit is much reduced. The energy of a surge tends to set the diaphragm in motion and, when the latter is freely resonant as in the old receiver, the motion persists for several cycles; in a well damped diaphragm system, however, the surge energy is dissipated too rapidly to be fully appreciated by the ear.

The improvement in articulation, and the reduced sensitivity to interfering noises are fully confirmed by an extensive field trial which was made by the British Post Office on a preliminary design of an improved operators' receiver. An overwhelming majority of the operators who used the new receivers remarked on their superior articulation and their lower sensitivity to line noises and clicks, in comparison with the older receivers in service.

There are certain special applications where the new receiver offers a marked advantage over the older type. These occur where the auditory range of level is abnormally reduced, as for example with deaf persons, or where listening is done under conditions of extremely

high external noise, such as those encountered in aircraft or in confined spaces with loud machine noise. Under such circumstances, it is necessary to use amplifiers to increase the receiver output to an audible level; the limit of amplification is reached when the receiver output at any frequency reaches the level of the threshold of feeling. Thus, with the older receivers, amplification may raise the narrow frequency band around the peak of the diaphragm resonance to this limiting level before any other frequencies have been rendered audible, and the resulting sounds emitted by the receiver may be scarcely intelligible. With the new receiver, however, the flatter characteristic enables practically the whole frequency band up to 3 000 p : s to be rendered audible, a marked gain in intelligibility resulting.

METHOD OF OBTAINING IMPROVED CHARACTERISTIC

The old receivers have at least two pronounced diaphragm resonances. These are indicated, for the case of Receiver 1-L, in Fig. 1, curve C; they are the fundamental resonance f_0 at about 1 100 p : s and resonance

in the single circle mode of vibration f_{c1} at about 3 500 p : s. The latter resonance occurs at too high a frequency to be of value on circuits with a cut-off frequency in the neighbourhood of 3 000 p : s. An irregularity also often occurs in the frequency response curve at about 3 000 p : s; various explanations can be advanced as to the cause of this irregularity, but they have not been experimentally checked. Its effect in the old receiver is negligible; in the new receiver, it disappears from the characteristic.

In the new receiver, equalisation of the characteristic has been carried out over the frequency range from 200 to 3 200 p : s, on the assumption that this range is the most likely to be adopted internationally for commercial telephony. In general, the method of equalisation consists in replacing the fundamental diaphragm resonance of the older receiver by three well damped resonances suitably spaced within the above mentioned frequency range; these are shown in Fig. 1, curves A and B, at f_A , f_B and f_C on the frequency response curves of the equalised receivers. The method of obtaining the three resonances will be apparent from consideration of the schematic of Fig. 2 in conjunction with Fig. 3 showing the essential features of Receiver Inset 2-P. In Fig. 2, the mechanical and acoustical constants of the receiver, when closely coupled to a human ear, are indicated in the form of an analogous electrical circuit, in which mass, stiffness, and mechanical resistance are shown, respectively, as inductance, electrical stiffness (reciprocal of capacitance), and resistance. The electrical constants of the receiver are shown in the same schematic and coupled to the mechanical side of the receiver by means of the force factor G .⁽¹⁰⁾

In order to obtain an approximate idea of the

working of the receiver, the mechanical system of the receiver may be considered as divided into three main sections, indicated on the schematic as ab , bc and cd . For the old receivers the schematic would be approximately represented by the part ab only, thus explaining the fundamental diaphragm resonance which

appears at a frequency $f_0 = \frac{1}{2\pi} \sqrt{\frac{s_0}{m_0}}$. In the

equalised receiver a shallow chamber has been added behind the diaphragm; the wall of this chamber contains a small hole which opens into the back space of the receiver and which is covered with silk of fine mesh. The air in the chamber has a stiffness s_1 , the plug of air in the "leak" hole has a mass m_1 , and the silk covering to the hole provides resistance r_1 ; the complete system s_1 , m_1 , r_1 , constitutes the anti-resonant circuit bc in series with the part ab . These two coupled circuits give rise to the two peaks at f_A and f_B , separated by a trough in the frequency response curve of the receiver. In the case of Receiver Inset 2-P the positions of the two peaks have been arranged at about 300 p : s and 1 700 p : s by choice of the constants m_0 , s_0 , m_1 , s_1 . In the case of the head receiver it has been possible to arrange

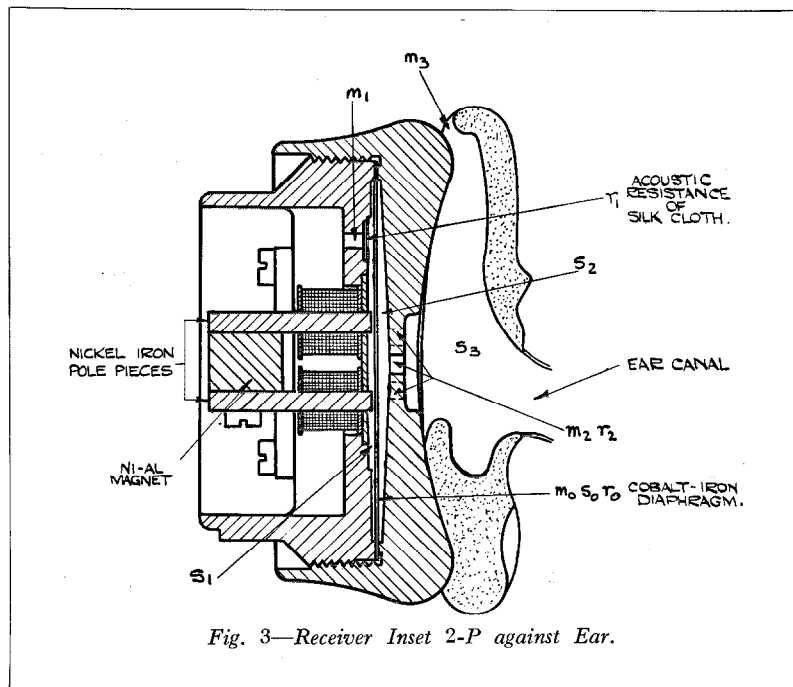

Fig. 3—Receiver Inset 2-P against Ear.

the two peaks at about 300 p : s and 2 000 p : s, giving a still flatter curve, as a result of greater freedom of choice of the constants m_0 , s_0 , m_1 , s_1 . In both forms of the new receiver the function of the resistance r_1 is to smooth out the peaks and the trough; its effect is more pronounced at the lower frequency f_A where the resonance has, in fact, nearly disappeared. The correct value of resistance has been obtained by choosing a silk of suitable specific acoustic resistance to cover the hole in the acoustic chamber.

The part *cd* of the schematic is constituted as follows: The acoustic chamber between the diaphragm and the earcap has a stiffness s_2 ; the volume of air enclosed by the outside of the earpiece and the ear, including the ear cavity, has a stiffness s_3 ; and the plug of air in the holes of the earcap has a mass m_2 . This part of the circuit gives rise to the so-called "earcap resonance" at f_c ; it may be considered approximately as a series resonator of the well-known Helmholtz type, in which m_2 and $(s_2 + s_3)$ provide the reactive constants; the resonance

frequency $f_c = \frac{1}{2\pi} \sqrt{\frac{(s_2 + s_3)}{m_2}}$ approxi-

mately. The resonance frequency f_c has been designed for a value of about 2 900 p : s by choice of the constants m_2 and s_2 ; the value for the stiffness s_3 has been assumed to be that of an air volume of 4.5 cubic centimetres. In Receiver 1-L and similar receivers, the values of s_2 and m_2 are such that this resonance occurs above the working frequency range of the receiver; moreover, it is imperceptible because of heavy damping, the flatness of the resonance being due both to the distributed mass at the several holes of an ordinary earpiece and to the small ratio of reactance to resistance.⁽¹¹⁾ In the new receiver the values of both m_2 and s_2 have been increased above those of the old receivers, m_2 considerably, and s_2 to a lesser degree; the mass m_2 has been concentrated at four small holes near the centre of the earpieces, these changes resulting in the appearance of a moderately sharp resonance in the region of 2 900 p : s. The space between the diaphragm and the earcap has been reduced in volume in order to increase s_2 . As commonly used on the older receivers, this chamber has the shape of a

flat cylinder between the diaphragm and the earcap; and, owing to the diaphragm amplitude varying from zero at the clamped edge to a maximum near the centre, pressure differences exist between edge and centre with consequent radial air flow to the periphery as well as to the central outlet provided by the earcap holes. If, in the new receiver, the same cylindrical shape had been adopted, and the separation had been reduced sufficiently to give the required volume reduction, the resistance to radial movements of air in the resulting narrow space (0.015") would have been considerable, so that the receiver response over the working frequency range would have been excessively damped. In the new receiver, however, loss of energy from this cause has been almost entirely avoided by making the shape of the air space correspond to the diaphragm displacement; a practical approximation to this condition has been obtained by making the interior surface of the earcap conical, the height of the cone being 0.050". This arrangement not only gives a uniform pressure distribution from periphery to centre so that all air flow occurs towards the central outlet, but also provides an increasing sectional area corresponding to the increasing air flow from periphery to centre.⁽¹²⁾

When a receiver is held to the ear, there is often a small leakage to the outer air owing to imperfect contact between the earcap and the ear. For normally occurring leaks, the effect on the receiver characteristic is apparent only at frequencies below about 600 p : s. The presence of such a leak is indicated in the schematic (Fig. 2) by the mass m_3 shown in dotted lines; the effect on the frequency response curve of the receiver is shown by the dotted curve D in Fig. 1.

THE MAGNETIC CIRCUIT

Where damping is employed in order to assist the equalisation of the receiver, as in the new receivers described, a reduction in volume efficiency necessarily tends to occur. To avoid such reduction, means have been employed to raise the volume efficiency of the receivers by redesigning the magnetic circuit.

In electro-magnetic receivers the diaphragm performs a double function. Firstly, it is the medium of transformation of electrical into

mechanical energy; and, secondly, it is the radiator of acoustical energy. Thus both the magnetic and the mechanical properties of the diaphragm are involved in the working of the receiver. A criterion, taking account of this dual function of the diaphragm as well as of other factors, has recently been developed by the Bell Telephone Labs. for judging the performance of equalised receivers.⁽⁵⁾ It is embodied in the following expression:

$$\frac{\text{force factor} \times \text{effective area of diaphragm}}{\text{turns} \times \text{effective mass of diaphragm}}$$

Since there are under consideration a diaphragm of uniform thickness and only one type of diaphragm flexure (which in the case of the new receiver is that of a flat clamped diaphragm of conventional type) and since, moreover, the density of available diaphragm materials is approximately constant, the above criterion can be reduced to the following expression:

$$\frac{\text{force factor}}{\text{turns} \times \text{thickness of diaphragm}}$$

The various parameters which are involved in this simplified figure of merit are as follows:

- (1) the magnetic material of the pole pieces,
- (2) the magnetic material of the diaphragm,
- (3) sectional area of pole pieces,
- (4) separation of diaphragm and pole pieces,
- (5) turns on the receiver winding,
- (6) the polarising flux,
- (7) thickness of diaphragm.

The manner in which these various parameters have been chosen will now be described.

For the material of the pole pieces a nickel-iron alloy containing 36 per cent. nickel⁽⁴⁾ has been chosen. This alloy, under the condition of a superimposed polarising field, has the advantage of high A.C. permeability, the maximum value being about twice that for magnetic iron. It also has a specific resistance about six times that of magnetic iron with consequent smaller eddy current losses. For the diaphragm material, high permeability under conditions of high flux density is essential since the additional need for small diaphragm mass demands the thinnest permissible diaphragm. The material which has been chosen consists of an alloy containing approximately equal proportions of iron and cobalt.^{(4), (13)} It is

somewhat difficult to roll into the thin strip required for receiver diaphragms, but this handicap has been successfully overcome in the material manufactured by Standard Telephones and Cables, Limited, under the trade name "Permendur" for which trade mark protection has been applied. This material has the valuable property of retaining a high permeability at high values of flux density; the maximum A.C. permeability with a superimposed D.C. field is about three or four times that for stalloy.

The pole piece sectional area is the maximum practicable, taking into account spatial and manufacturing limitations. The separation between pole pieces and diaphragm has been chosen at the minimum value consistent with security against pulling-in of the diaphragm to the pole pieces; this factor is, of course, also related to the diaphragm thickness, the polarising flux, and indirectly to all the other parameters. The number of turns on the winding has been chosen in conjunction with the other factors so as to give correct impedance matching of the receiver to the standard British Post Office sub-station circuit.

With these parameters decided, only the polarising flux and the thickness of diaphragm required determination. These two parameters react mutually in a complex manner and they were, therefore, selected as a result of experiments covering a range of variation of polarising flux and diaphragm thickness. It can be shown that the force factor G , which is defined as the ratio of the mechanical force produced to the magnitude of the current producing it, may be expressed in terms of the magnetic flux and the number of turns in the receiver winding by the equation: $G = n \frac{d\phi}{da}$, where n is the number

of turns and $\frac{d\phi}{da}$ is the rate at which the flux interlinking the diaphragm and the pole pieces varies with diaphragm displacement. In carrying out the range of experiments with different polarising flux and diaphragm thickness, the rate of change of the magnetic flux was measured directly by giving the diaphragm a sudden small displacement of accurately measured magnitude and observing the resulting deflection of a

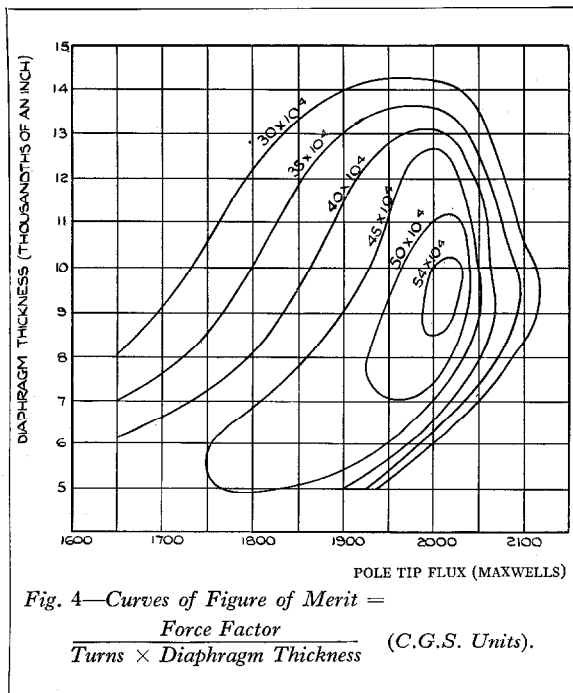

calibrated ballistic galvanometer connected to the receiver coil terminals. In this experimental work an electro-magnet was used in order to give a ready variation of the polarising flux. Using the value of force factor so measured, the

figure of merit,
$$\frac{\text{force factor}}{\text{turns} \times \text{diaphragm thickness}},$$

was plotted against the two parameters, polarising flux and diaphragm thickness. The curves are shown in Fig. 4, from which it will be seen that the optimum value of the figure of merit occurs for a diaphragm 0.0095" thick, and a polarising flux of 2010 maxwells. The values of polarising flux are those measured by a magnetic iron yoke placed across the pole faces of the receiver. A magnet of nickel-aluminium-iron has been found suitable for providing the required value of polarising flux. In Fig. 5 the variation of force factor with airgap is shown for a diaphragm 0.0097" thick, which is near the nominal thickness value. It will be noted that the rate of change of force factor with airgap in the neighbourhood of the nominal working airgap of 0.009" is not very rapid, so that variations of airgap due to diaphragm distortions will not greatly affect the receiver efficiency.

CONSTRUCTIONAL DETAILS OF THE NEW RECEIVERS

The construction of Receiver 2-P is shown in schematic form in Fig. 3. It will be seen that, in general arrangement, the receiver is of the inset type similar to Receiver 1-L and can be secured to the microtelephone handle by two fixing screws which also serve to make the electrical connections. The frame of the receiver is of die-cast aluminium and, besides mounting the pole pieces and magnet assembly, terminals, etc., it incorporates the shallow chamber behind the diaphragm with the small silk covered hole forming the system shown in the schematic of Fig. 2 as m_1, s_1, r_1 . The small silk disc, which provides the acoustic resistance r_1 , is placed in the counter bore of a hole in the frame, and is held in place by a metal washer which is secured by staking the metal of the frame in three places. The assembly, consisting of pole-pieces, coils, and magnet, is secured by four fixing screws to the frame; the pole tips project through slots in a plate insulator which is suitably sealed to the frame and to the pole tips, to make an airtight joint. During manufacture the receiver is tested with earcap and diaphragm assembled, by applying air pressure via one of the screw fixing holes of the receiver, the other screw fixing hole being temporarily blocked. The air flow under these conditions is required to be within certain limits; thus the acoustic resistance of the silk disc and the sealing of the receiver are both tested at the same time.

In general construction the new head receiver resembles Receiver Inset 2-P. It has the same

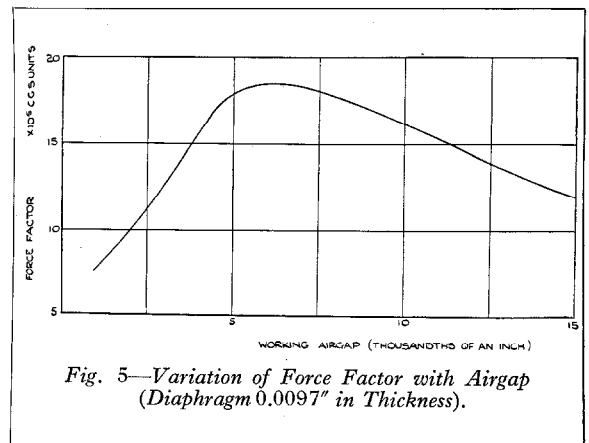

magnet and pole-pieces assembly, but the unit has been reduced in weight somewhat by the substitution of a bakelite frame or case for the die-cast case of Receiver Inset 2-P. The cord connections are made to moulded-in metal inserts in the bakelite frame. A pressed sheet aluminium cover is fixed to the rear of the unit by two screws which, in the case of Receiver Headgear 10-A, mark 2, also serve to attach the spring clip which holds the ball-ended headband. The unit can also readily be arranged to suit a stirrup type of headband.

The earcaps of the new receivers are of moulded bakelite and, in the case of Receiver 2-P, the external dimensions are very nearly the same as those of the earcap used on Receiver Inset 1-L. There is, however, one important difference in the outside shape of the new receiver earcaps. Since the four holes in the earcap are involved in determining the frequency of the earcap resonance, it is essential that they be not obscured by the ear cartilage when the receiver is in use. For this reason the holes are arranged in the bottom of a small recess about 0.5" diameter \times 0.1" deep in the front of the earcap.

CONCLUSION

The new telephone receivers represent a marked step forward in receiver design. While the improvement is primarily one of quality, it has been accomplished without sacrifice of receiver efficiency. The need for and economy resulting from improved overall quality are now generally recognised throughout the telephone world and are reflected in the recent C.C.I.F. decision to increase to 300-3 400 p : s the band to be effectively transmitted from subscriber to subscriber. These limits are considerably wider than those heretofore accepted. Nevertheless, they still necessitate the fullest economy in the utilization of the band effectively transmitted. To this end all apparatus involved in the transmission path should have a uniform frequency response over the transmitted frequency band. In these respects the new receivers show an outstanding advance over the older commercial receivers.

In conclusion, the author desires to acknow-

ledge the co-operation and advice given by Messrs. West and Pearce, of the British Post Office, during the progress of the development of the new receiver, in particular, for advice regarding the spacing of the resonances in the receiver characteristic and certain features in the earcap design.

BIBLIOGRAPHY

- (1) H. Fletcher and J. C. Steinberg : "Articulation Testing Methods," *Bell System Technical Journal*, Vol. VIII, 1929, p. 806.
- (2) W. H. Martin : "Rating the Transmission Performance of Telephone Circuits," *Bell System Technical Journal*, Vol. X, 1931, p. 116.
- (3) A. H. Inglis, C. H. G. Gray and R. T. Jenkins : "A Voice and Ear for Telephone Measurements," *Bell System Technical Journal*, Vol. XI, 1932, p. 293. W. West, "An Artificial Ear," *P.O.E.E. Journal*, Vol. 22, 1929, p. 260.
- (4) G. W. Elmen : "Magnetic Alloys of Iron, Nickel and Cobalt," *Bell System Technical Journal*, Vol. XV, 1936, p. 113.
- (5) H. A. Frederick. U.S. Pat. 1 273 351.
A. E. Swickard. U.S. Pat. 1 964 604 and 2 022 060.
L. A. Morrison and E. E. Mott. B.P. 481 351.
- (6) H. Jacoby and H. Panzerbieter : "Uber Moderne Mikrophone und Telephone," *Elektrische Nachrichten Technik*, Vol. 13, 1936, p. 75.
- (7) K. Kobayasi : "A Measure and the Limit of the Quality of Telephone Receivers," *Nippon Electrical Communication Eng. Jnl.*, No. 6, pp. 114-118. H. Ikeda : "A High Quality Telephone Receiver," *loc. cit.*, pp. 119-121.
- (8) W. West and D. McMillan : "Characteristics of Telephone Receivers," *I.E.E. Journal*, Vol. 75, Sept. 1934, p. 317 ; also W. West : *British Post Office Engineering Dept., Research Reports* Nos. 8358 and 9542 (unpublished).
- (9) R. L. Wegel and C. E. Lane : "The Auditory Masking of One Pure Tone by Another and its Probable Relation to the Dynamics of the Inner Ear," *Physical Review*, 2nd series, Vol. 23, No. 2, 1924, p. 266.
- (10) A. E. Kennelly : "Electrical Vibration Instruments," 1923, Macmillan, New York, Chapter VIII, p. 88.
- (11) A. E. Kennelly : *Loc. cit.*, Chapter XVII.
- (12) H. C. Harrison, P. B. Flanders, A. L. Thuras and E. B. Craft : "Sound Passage in Acoustical Instruments," B.P. 266 395.
L. C. Pocock and J. S. P. Robertson. B.P. 481 740.
- (13) J. H. White and C. V. Wahl : "Improved Magnetic Compositions including principally Iron and Cobalt," B.P. 404 011.
- (14) W. C. Jones : "Instruments for the New Telephone Sets," *Bell System Technical Journal*, Vol. XVII, 1938, pp. 338-357.

The Use of the High-Vacuum Cathode-Ray Tube for Recording High-Speed Transient Phenomena¹

By Captain D. I. McGILLEWIE, R.N., A.M.I.E.E.

SUMMARY

The paper describes a portable apparatus operated from the 50-cycle A.C. mains and devised for the visual examination and/or photographic recording of controlled or uncontrolled high-speed transient phenomena.

A high-vacuum glass-bulb type of cathode-ray tube is employed, with external photography. The maximum working voltage is 5 000 volts, and the beam is normally shut off by means of a negative voltage on the modulating grid. A 3-electrode spark-gap is incorporated and is so arranged that when broken down by an incoming transient, or artificially-applied impulse, it brings the cathode-ray spot to full brilliance almost instantaneously for a controllable length of time, and, at the same time, sweeps it across the screen at a speed which can be varied from 1 or 2 microseconds to 1 millisecond for a single horizontal sweep. A simple oscillatory circuit operated by the spark-gap is arranged to provide a time-marking wave when desired.

Introduction

THE development of the hot-cathode, high-vacuum, electrostatically-focused, sealed-off glass-bulb type of cathode-ray tube was primarily due to the demand for a tube suitable for television in which the intensity of the beam could be modulated from maximum brilliance to complete shut-off without loss of focus, by a small controlling voltage, and in which no origin distortion existed.

The employment of this type of tube for television purposes has to some extent obscured its potentialities in other directions, more particularly those connected with the investigation of high-speed transient phenomena. Recent proposals² for the standardisation of impulse-voltage testing provide but one indication of the demand which must shortly arise for apparatus for recording these and similar high-speed transients, but of a more portable and less expensive nature than the high-voltage continuously-evacuated tube, as developed by Dufour, Rogowski, Burch, Whelpton, and others.

The high-vacuum tube is essentially suitable for this purpose, as its focus is not impaired at the highest of writing speeds, while the limits of high-frequency response are only reached when the Holman³ sensitivity effect becomes

apparent, i.e., when the time of transit of an electron from one edge of a deflecting plate to the other edge in the direction of motion of the stream is an appreciable fraction of the time-interval between successive waves. (With the tube employed, working at 5 000 volts, this effect only begins to operate when approaching 200 Mc.)

Further, great improvements have recently been effected in the powders⁴ which are used to coat the interior surface of the large end of the glass bulb, i.e., the screen of the tube, so that it is now possible to obtain with the high-vacuum tube operated at about 5 000 volts visual records of single traces of almost the highest-speed transients which have as yet been explored; while the photographic results obtainable, although not of course equal to those achieved with the high-voltage tube, are nevertheless sufficiently fast for a great deal of work which at present is only possible with the latter type of apparatus.

The author has long been convinced of the possibilities for high-speed work of the glass-bulb type of cathode-ray tube, and in December, 1934,⁵ he was able to obtain photographic records of writing speeds of the order of 30 km. per sec. using a gas-focused type of tube at 3 000 volts. These tubes, however, were unsatisfactory at such a voltage and suffered from other defects, mainly connected with variation

¹ Paper read on 4th March, 1938, before the Meter and Instrument Section of the Institution of Electrical Engineers, London.

² *Journal I.E.E.*, 1936, vol. 78, p. 257.

³ *Wireless Engineer*, 1933, vol. 10, p. 430.

⁴ *Journal I.E.E.*, 1936, vol. 79, p. 11.

⁵ *Journal I.E.E.*, 1935, vol. 76, p. 670.

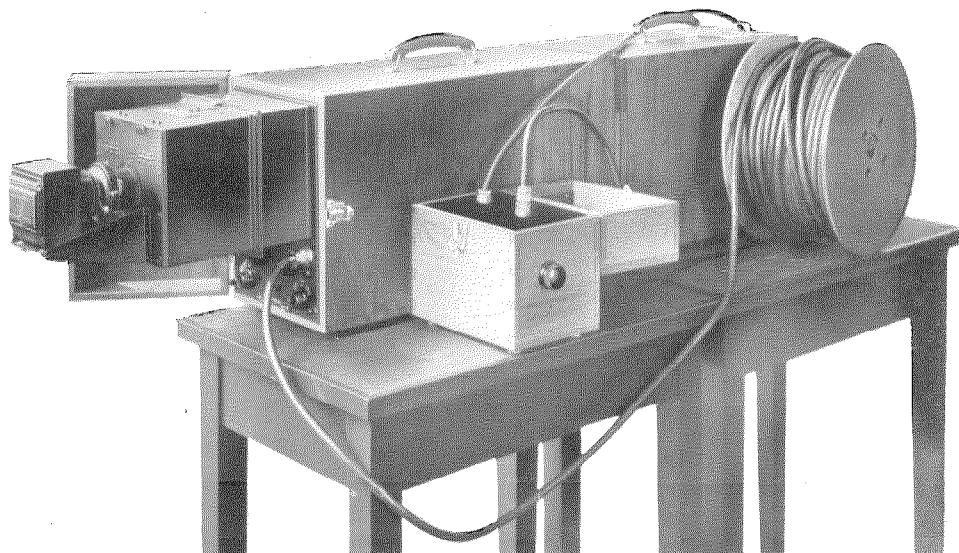

Transient Recorder Equipment, with Delay Cable in Circuit, connected up for recording Surge Generator Wave.

of focus with writing speed, and high plate-conductivity with large values of positive deflecting voltage. With the advent of the high-vacuum tube it became possible to produce a much more stable and reliable apparatus, capable of recording at considerably higher writing speeds.

Initiation of Beam

The main problem which had to be solved in order to make practical use of the high-vacuum tube for transient work was, as in the case of the high-voltage type of tube, to initiate the beam as nearly as possible simultaneously with the arrival of the transient to be recorded, and to shut it off again immediately the record was completed. The method⁶ whereby this has been achieved can be explained by reference to Fig. 1. S is a 3-electrode spark-gap in which the outer electrodes are charged to about 1 800 volts positive and negative respectively with regard to earth, the centre electrode being connected to earth through a resistance of the order of 1 megohm.

The negatively charged electrode is connected through the condenser C_1 and the resistance R_1

to the modulating grid G, which is supplied from the potentiometer P with a variable voltage, negative with respect to the cathode K. This negative voltage is fed to the grid through the decoupling resistance R_3 with its associated condenser C_2 , and through the resistance R_2 . The intensity of the beam can be varied by altering the potential supplied to the grid, a voltage negative with respect to the cathode of about 30 volts having the effect of completely shutting off the beam. This is the condition under which the apparatus is operated.

The gaps between the electrodes are adjusted to the minimum distances sufficient to prevent sparkover, and in this state can be broken down with a very short time-lag by the application to the centre electrode of a pulse of about 500 volts of either polarity. When breakdown takes place, the negatively charged electrode rises suddenly to earth potential and a positive pulse is applied through C_1 , R_1 , R_2 , and C_2 to the cathode, and so via the decoupling condenser C_3 to earth.

By suitable proportioning of R_1 and R_2 the voltage generated between grid and cathode is arranged to be just sufficient to annul the negative shut-off voltage supplied by the potentiometer P, and the beam is brought to

⁶ Patent No. 475903.

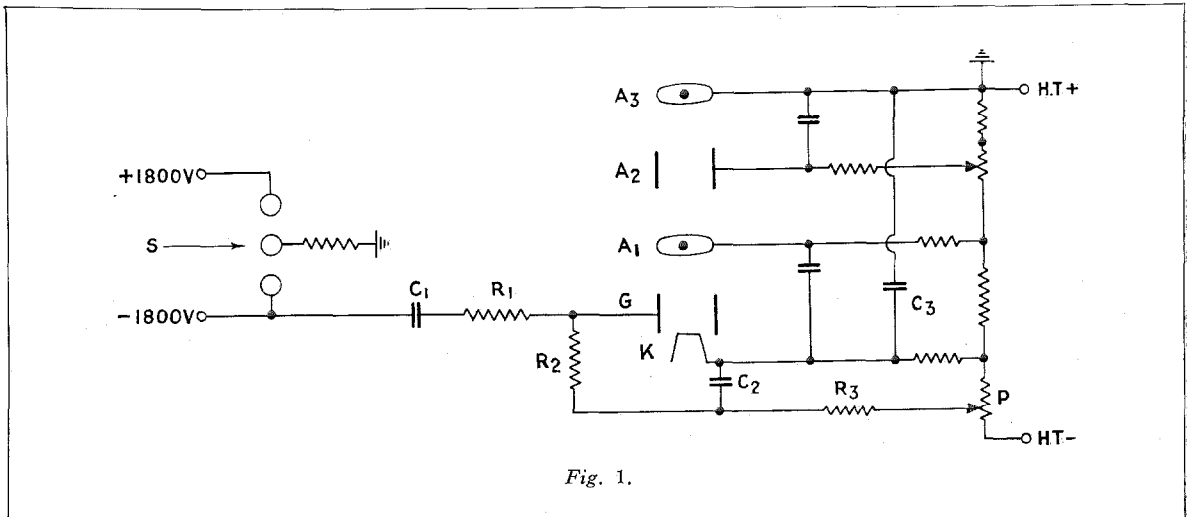

Fig. 1.

full brilliance in a fraction of a microsecond. The actual time depends on the grid-cathode capacitance (which is of the order of $15 \mu\mu\text{F}$) and the value of the resistance R_1 . The time during which the beam remains "modulated in" depends upon the time-constant C_1R_1 . It is advisable to shut off the beam when it has completely traversed the screen, to prevent a slight general fluorescence which occurs if it is deflected on to the walls of the tube. A "duration" control is therefore arranged such that, by variation of C_1 and/or the combination R_1R_2 , keeping the ratio R_1/R_2 constant, it is possible to vary the duration of the sweep from about 1 or 2 microseconds to more than 1 000 microseconds. At the position of shortest duration, i.e., for the fastest sweep, the time taken to charge up the grid-cathode capacitance is arranged to be of the order of 0.02 microsecond. For the lowest speeds of sweep, since it is not very convenient to have large values of C_1 , a compromise is arranged and R_1 and R_2 are also increased; but even then the time

taken to charge up the grid-cathode capacitance is only of the order of 0.2 microsecond, which, for a sweep lasting 1 000 microseconds, is negligible.

Before a detailed description is given of the apparatus, it will be convenient to indicate the method adopted for obtaining a variable-speed sweep and a time-marking device integral with the apparatus.

Time Sweep

The spark-gap is used to operate a balanced variable-speed sweep, the circuit of which is shown diagrammatically in Fig. 2.

The two sweep condensers C_s are arranged in series with the two "ganged" variable resistances R_s , and with the spark-gap. When the latter breaks down, the condensers C_s discharge through the resistances and the sweep voltage is applied to the horizontal deflecting plates DX_1 and DX_2 through the coupling condensers C_c and damping resistances R_D .

Time-Marking Device

The spark-gap has a third function to perform, namely to operate, when required, a timing wave. The diagrammatic circuit of the time-marking device is shown in Fig. 3.

T is a small transformer, the secondary consisting of a large number of turns wound on a small toroidal permalloy dust core, while the primary is formed with a few turns of wire wound outside the secondary, and is in series with condenser C_1 and resistance R. If the

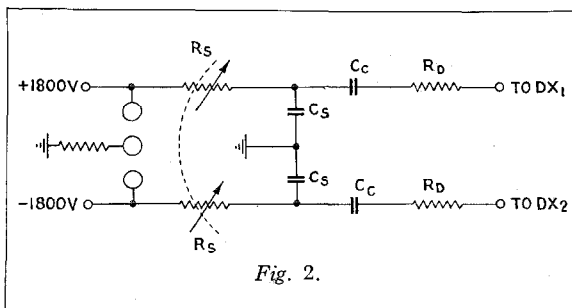

Fig. 2.

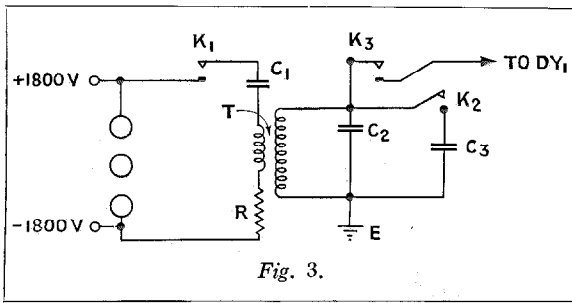

Fig. 3.

recorded before the amplitude is too much reduced to be effective.

Description of Apparatus

The apparatus is constructed in two units, the mains unit and the tube unit, each being housed in a teak box. The various connections between the units are made by a number of plugs in the back of the tube unit, which fit into corresponding sockets in the mains unit when the two are placed back to back. Two of the plugs are connected by a strap which is introduced into the mains circuit, thus providing a simple and effective safety arrangement. The spark-gap is arranged at the end of the mains unit farthest from the tube unit, and has a viewing window above it permitting visual observation or, if desired, quartz-lamp excitation of the gap. On the end panel of the mains unit are the controls for No. 3 anode voltage, timing wave, speed of sweep, duration of sweep, and adjustment of spark-gap; also the mains plug, mains tapping, on-off switch, and

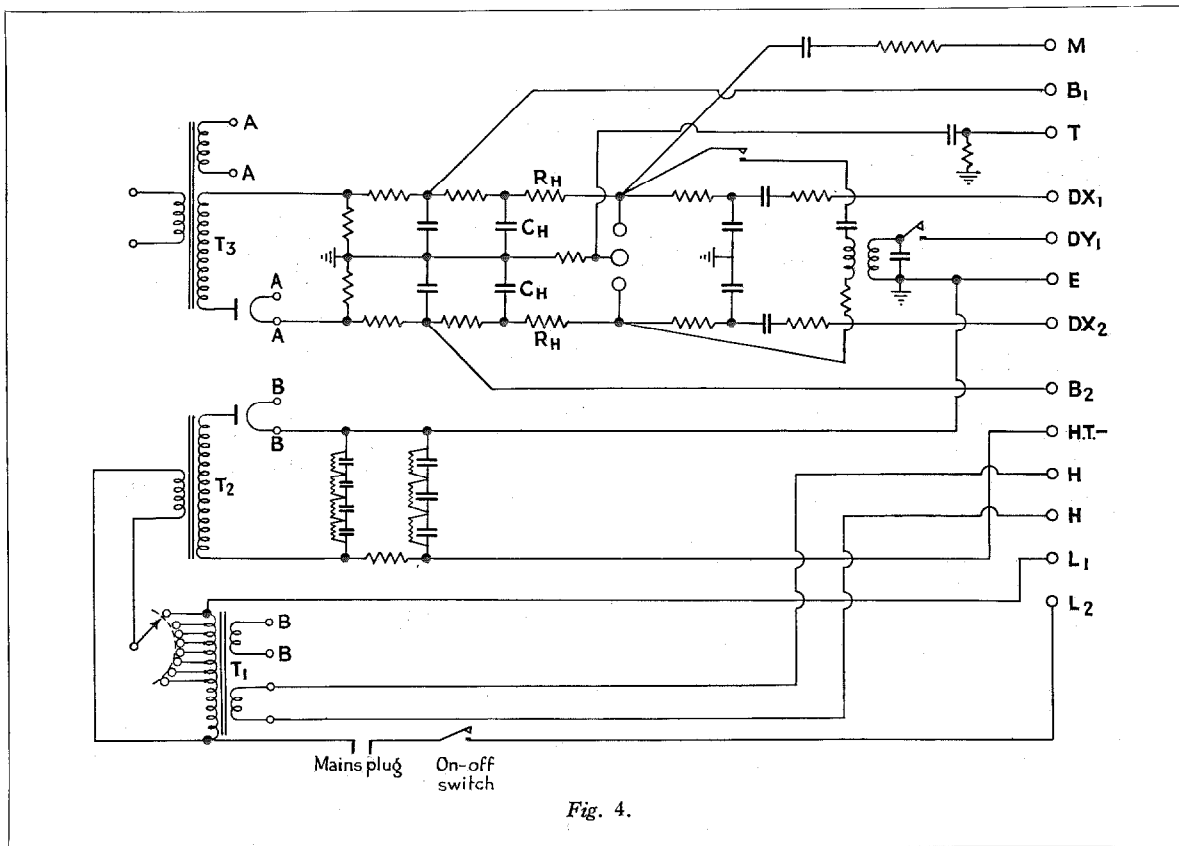
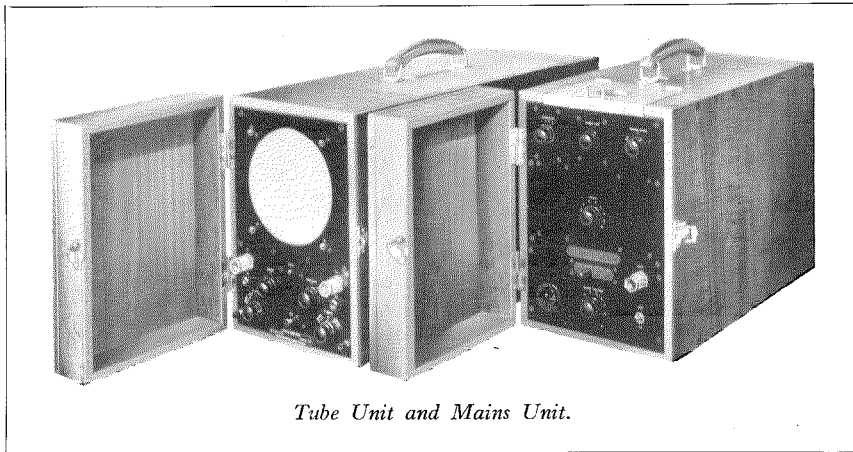

Fig. 4.

switch K_1 is closed, breakdown of the gap causes C_1 to discharge through the primary winding and resistance R , giving a shock excitation of the secondary and causing it to oscillate at a frequency tuned by C_2 to 1 Mc. and by C_2 and C_3 in parallel (if K_2 is closed) to 250 kc. (These values can be altered if necessary.) The value of R for optimum results was found by trial. The timing wave is applied between DY_1 and No. 3 anode through the switch K_3 and the earthing connection E . The decrement of the circuit is sufficiently low to enable a considerable number of waves to be



Tube Unit and Mains Unit.

providing not only the usual mains tapping-points (not shown on the diagram) but also a convenient method of varying No. 3 anode voltage by variation of the primary voltage on T_2 .

The maximum voltage for which the mains unit is designed is 6 000 volts, but so far only 5 000 volts have been used, this being the

maximum for which the tubes are designed. The smoothing condensers are arranged in series with 10-megohm grid leaks across each, in order to make it possible to use a 2 000-volt type of condenser of relatively small size.

In the spark-gap supply the condensers C_H in conjunction with resistances R_H provide the necessary spark-heating circuit.

The tube unit is shown in diagrammatic form in Fig. 5. P is the push button for tripping the spark-gap, the decoupled condenser C_P providing the voltage required without upsetting the biasing or spark circuits. The

The transformer T_1 is tapped at a number of points on its primary, thus

The tube unit is shown in diagrammatic form in Fig. 5. P is the push button for tripping the spark-gap, the decoupled condenser C_P providing the voltage required without upsetting the biasing or spark circuits. The

The transformer T_1 is tapped at a number of points on its primary, thus

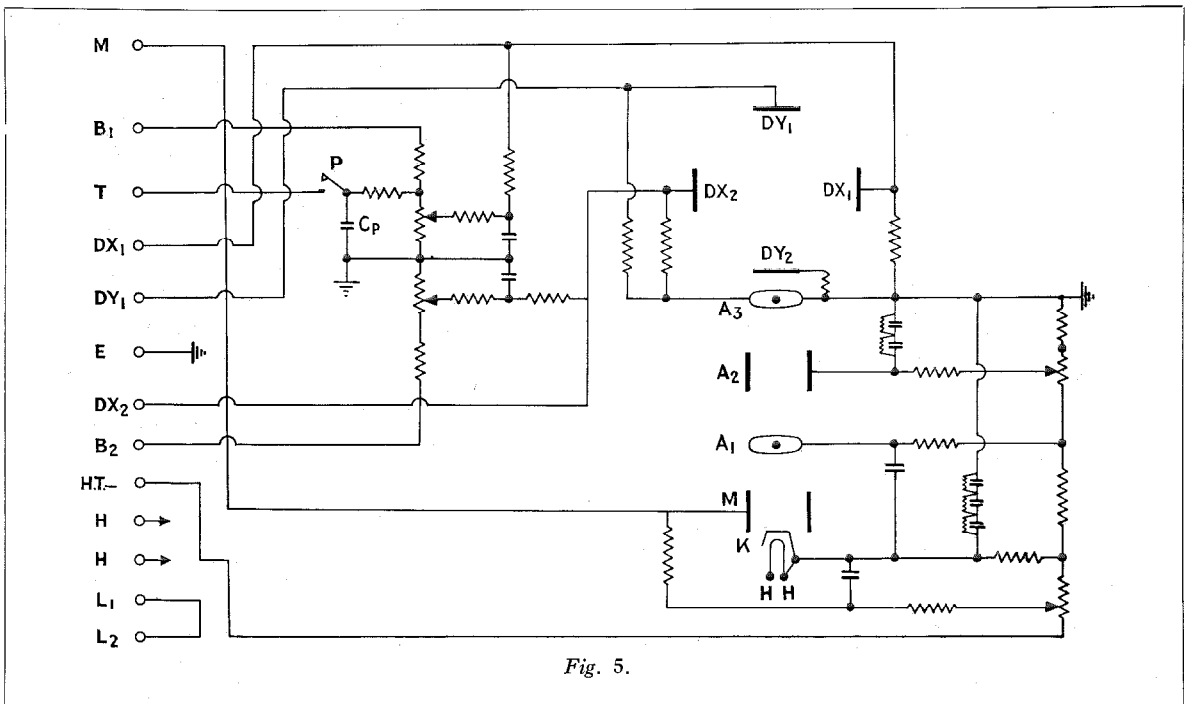

Fig. 5.

decoupling condensers for the cathode and for No. 2 anode are of the same type and are used for the same reason as those already referred to in connection with the mains unit. The rest of the circuit is self-explanatory.

Characteristics of Tube

The high-vacuum tube standardised at present for this apparatus is the 4063-AB tube manufactured by Standard Telephones and Cables, Ltd. Its characteristics are as follows: Screen diameter, $5\frac{1}{2}$ in.; colour of trace, blue; sensitivity (mm. per volt), $650/V$ for X -plates and $750/V$ for Y -plates, where V is the accelerating voltage; maximum anode voltage, 5 000 volts. Capacitances:⁷ Grid to all other electrodes strapped, $15\ \mu\mu\text{F}$; DX_1 to DX_2 , $1.5\ \mu\mu\text{F}$; DY_1 to DY_2 , $1.2\ \mu\mu\text{F}$; DX_1 or DX_2 to all other electrodes strapped, $12\ \mu\mu\text{F}$; DY_1 or DY_2 to all other electrodes strapped, $10\ \mu\mu\text{F}$; DX_1 and DX_2 strapped to DY_1 and DY_2 strapped, $6\ \mu\mu\text{F}$.

Conductivity curves for the DX and DY plates are shown as continuous lines in Fig. 6, the DX plates being those nearest the screen. It will be noted that the DY plates have an extremely high impedance. The slightly lower impedance of the DX plates is of no importance since they are used for the sweep. The sensitivity curves of the DX and DY plates are shown as broken lines in Fig. 6.

Operation

The apparatus is extremely simple to operate. The two units are placed back to back and are pushed together. A good earth connection is made to the earth terminal on the front of the tube unit, and the controls on the tube unit are set as follows: Intensity control to "Off"; focus control and X and Y shift controls in their central positions. The spark-gap is then inspected through the viewing window and the central electrode withdrawn to a distance sufficient to prevent sparkover. With the mains tap in the correct position and

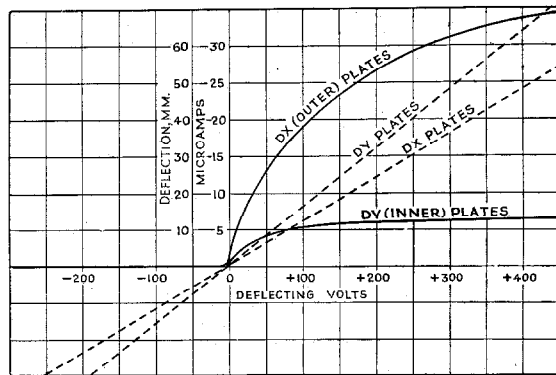

Fig. 6.

--- Sensitivity curves at 5 000 volts.
— Conductivity curves at 5 000 volts.

the required accelerating voltage selected by the voltage control, the mains supply is then switched on. After a pause of a minute or two to allow the heater to warm up, the intensity control is turned clockwise until the spot is seen. The focusing control is then adjusted until a fine spot is obtained, after which the intensity control is readjusted until the spot is just faded out. Next the spark-gap control is adjusted until sparkover just fails to occur, and the controls on the mains unit are set as follows: Timing-wave control to "Off"; sweep control to lowest speed; duration control to position No. 4. If the push button on the front of the tube unit is now pressed, the spot will appear about the centre of the screen and traverse to the right. The X and Y shifts, and the speed

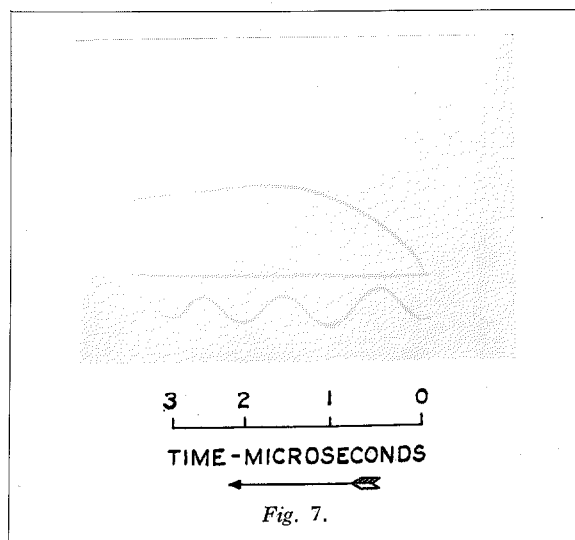
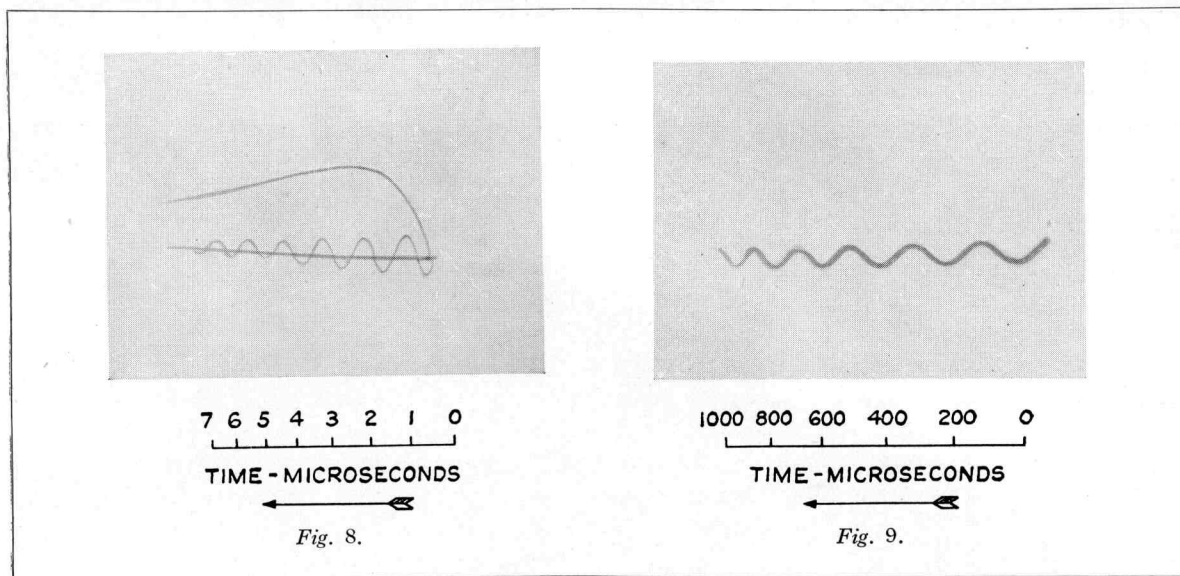

Fig. 7.

⁷ The capacitances between the two plates of each pair are given above for purposes of comparison with other makes of tubes. Actually, however, they do not appear to have any real value, since in practice some part of the circuit must have a metallic connection to No. 3 anode.



and duration controls, are then adjusted as required.

When possible, the transient to be recorded should be applied in push-pull to the Y-plates, as this obviates the defocusing effect which occurs when a large unbalanced voltage is applied between one plate and anode.

This latter condition is unfortunately the most usual in practice, but the defocusing effect can be reduced to a negligible quantity in the case of a unidirectional transient, when the polarity is known, by applying the transient to the DY-plate through a condenser and biasing the same plate with an unbalanced voltage of about half the value of the peak of the transient and of the opposite polarity. Alternatively, it is necessary to restrict the excursion of the spot to about three-quarters of the maximum working vertical displacement possible with balanced input.

The tripping impulse is applied to the terminal T on the front of the mains unit.

To obtain a zero line the push button is pressed with the timing-wave control at "Off." The timing wave is obtained by pressing the button with the timing-wave control at position No. 1 or No. 2, the first giving a 1-microsecond wave and the second a 4-microsecond wave.

The problems connected with irregularity of time-lag of spark-gap, the improvements which can be effected by ultra-violet radiation, and the theory and practice of delay cables, are

identical with those encountered in high-voltage oscillograph technique. It is therefore not proposed to discuss them here.

Photographic Records

Figs. 7 to 9 are reproduced from photographs actually taken with the apparatus. Fig. 7 shows a surge generator wave with zero line and 1-Megacycle timing wave superimposed. Fig. 8 shows the same wave with a slower time-sweep. Fig. 9 shows a 5-kc. wave and is included to prove that the apparatus will record transients of more than 1 millisecond's duration.⁸

All these records are of single traces, and Figs. 7 and 8 were automatically recorded, i.e., the surge generator itself was used to trip the spark-gap, a delay cable being used to enable the start of the wave to be recorded.

Fig. 10 is reproduced from a slightly touched-up photographic record which was made to establish the various time-delays involved in the apparatus. For this record the same surge generator was used as for Figs. 7 and 8, but the speed of sweep was increased to twice that of Fig. 7. Curves A and B (Fig. 10) show the results obtained with and without the delay cable respectively. Curve B has been extended

⁸ Since the reading of this paper the author has found it possible to extend the range to obtain records lasting up to 5 milliseconds.

backwards, as shown in broken lines, to meet the baseline at the point R.

P is the position of the spot before being shut off prior to recording, and Q is the starting point of curve A. The distance PR, corresponding to approximately 0.2 microsecond, represents the time-lag of the spark-gap, and PQ (approximately 0.04 microsecond) represents the time taken to initiate the beam. Owing to the very high recording speed the points Q and R could not be very accurately located on the record, but it was possible by visual examination of a number of surges to make certain that their positions as shown in Fig. 10 were approximately correct.

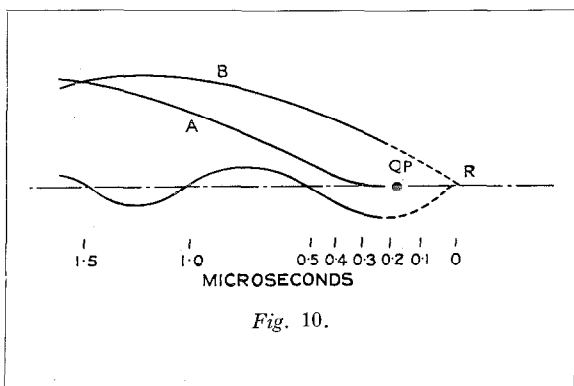

Fig. 10.

The camera used is fitted with an $f/1.9$ Dallmeyer lens. All the photographic records were taken on 6 cm. \times 4 $\frac{1}{2}$ cm. sensitized paper coated with Ilford F type emulsion, as this has been found the most effective medium for obtaining the highest-speed records. This accounts for the time axis moving from right to left.

When vacuum tubes are available to operate at higher voltages, still faster records will be possible with the same general arrangement. In cases when extremely low deflector-plate capacitance (to anode) is a necessity, the author is advised that no difficulty would be experienced in constructing special tubes with the vertical deflecting plates brought out through the walls of the tube. It would also be possible to reduce the size of the deflector plates if required, or, alternatively, to reduce the length of the tube in order to reduce sensitivity.

Trapezium Distortion

As has already been stated, most work connected with transient phenomena necessitates an unbalanced input to the tube, and it is well known that an unbalanced deflection on one plate of a pair, the other plate being earthed, causes a variation in sensitivity of the other pair of plates, giving rise to what is generally termed "trapezium distortion." It has been found, however, that as long as a balanced sweep is arranged on the plates nearest the screen, an unbalanced deflection on one of the other plates has practically no distorting effect. This is shown by Fig. 11, which is reproduced from a tracing taken of the envelope of a figure obtained by applying a balanced 50-cycle deflection on the DX plates (horizontal) with an unbalanced deflection on one or other of the DY plates. Fig. 12 shows the result obtained with the connections reversed, i.e., with the balanced sweep on the DY plates and an unbalanced deflection on one of the DX plates. The former arrangement is, of course, used in the apparatus. It will be apparent, therefore, that the apparatus can be calibrated statically with the greatest possible accuracy.

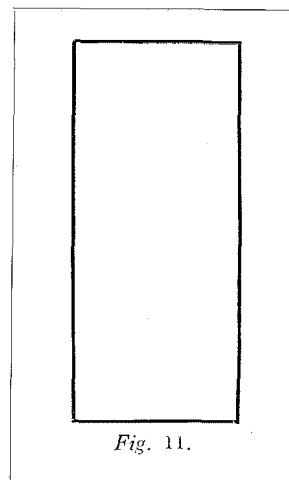

Fig. 11.

Conclusion

In conclusion, it should perhaps be emphasised that no appreciable shortening of the life of the tube is involved in leaving the apparatus ready for operation for long periods,

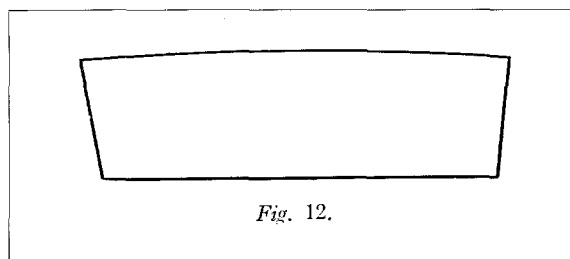

Fig. 12.

as the beam remains shut off except when the equipment is actually recording. This feature renders it especially suitable for the investigation of the effects of lightning surges on power transmission lines.

Acknowledgments

The author is indebted to Standard Telephones and Cables, Ltd., in whose labora-

tories at North Woolwich the whole of the development of the apparatus has been carried out, for permission to publish this paper. He has also to acknowledge his indebtedness to a number of colleagues in the Company's transmission laboratories for assistance on many occasions, and, in particular, to Mr. S. Hill and Mr. B. Newsam for assistance in the design and testing of the final model.



Assembling a centimetre-wave tube having an anode with a radius of eight-thousandths of an inch. Because of its small size, this type of tube is assembled under a binocular magnifier. (Les Laboratoires, L.M.T., Paris.)

A Museum of Electronic Apparatus

By R. McV. WESTON

ELECTRICAL communication to-day is very largely dependent on the thermionic valve, and this piece of apparatus, in its many forms, has been developed to its present degree of efficiency and reliability in the space of about thirty-three years. During the first ten years, progress was extremely slow; but, during the last twenty-three years, it has been so rapid that it is difficult to appreciate the number of improvements that have been made.

With a view to preserving as many actual examples as possible of the various stages in the evolution of electronic apparatus, the writer has been engaged since 1920 in forming a private museum of thermionic valves, cathode-ray tubes and photo-electric cells. The museum is now of considerable size, as it contains some two thousand exhibits and illustrates almost

every important step in development up to the present day.

The collection is kept in the writer's private house in a large attic which has been specially adapted for the purpose. Owing to a sloping roof, the amount of wall space suitable for the display of specimens is limited, and in order to increase it the room is divided up into a series of bays by means of partitions. Roughly speaking, each bay accommodates only one type of specimen, such as diodes, triodes, tetrodes, etc., but it has not been possible to adhere strictly to this arrangement. The presence of the dividing partitions makes it impossible to photograph the collection as a whole, but Figs. 1 and 2 show as much as is possible from two points.

It would be quite impossible, in a limited

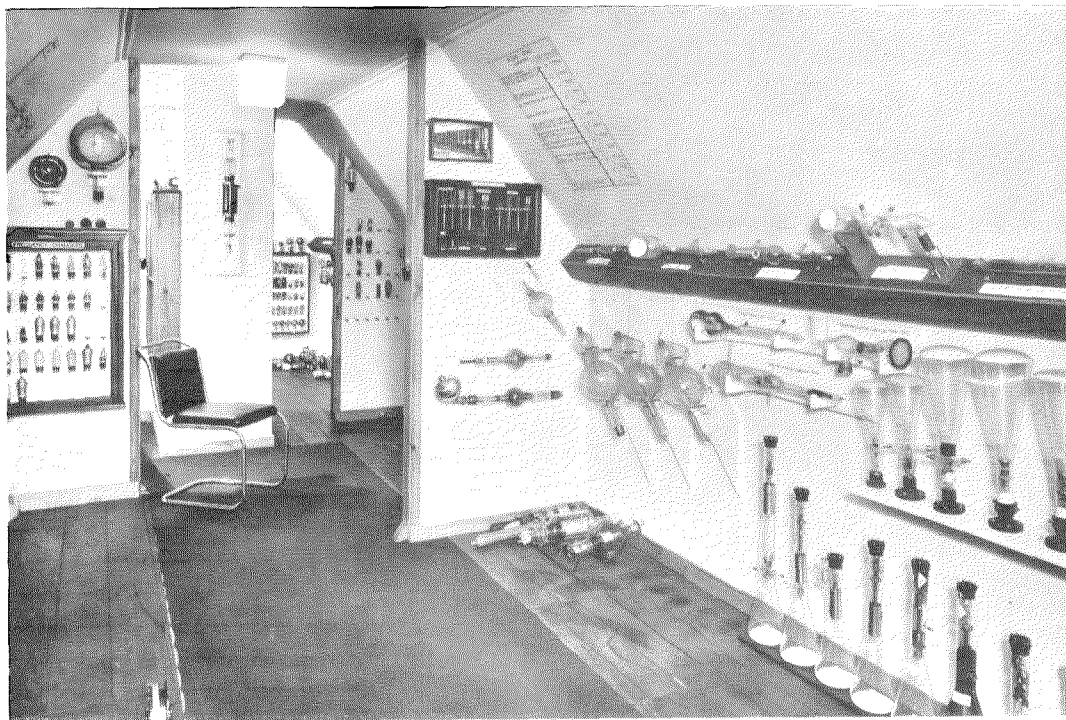

Fig. 1—View of Part of the Museum.

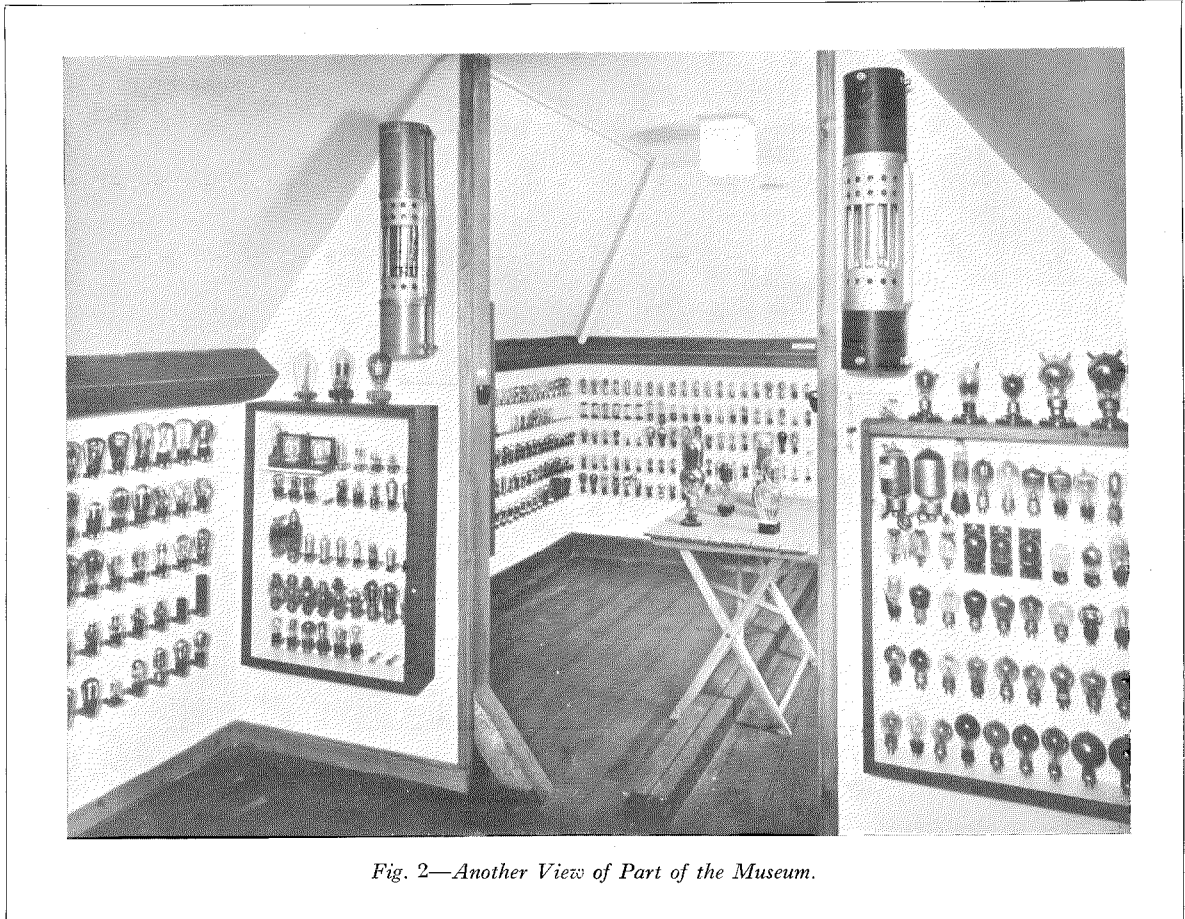

Fig. 2—Another View of Part of the Museum.

space, to deal with many exhibits in detail and accordingly only some of the more important types can be referred to. A brief look around the collection will serve, however, to recall to mind not only the fundamental inventions upon which all modern valves are based, but also to indicate the general trend of development from the early examples to those of the present time.

Thermionic Valves

The oldest exhibits, in the valve section, are the Fleming valves dating back to 1904, such as are shown in Fig. 3. These valves all have carbon filaments, and it is interesting to recall that they went out of favour soon after the introduction of the more sensitive crystal detector in 1906.

Turning now to the three electrode valve: although patented by De Forest in 1907, it does not appear to have been used commercially until

a considerably later date. It is understood that the British patent was allowed to expire in 1911. At that date von Lieben and Reisz produced their three electrode valve or relay, illustrated in Fig. 4. This valve had an oxide-coated platinum strip filament about one metre in length and contained mercury vapour. Meissner, in 1913, using one of these valves, generated continuous oscillations and transmitted speech over a distance of 36 kilometres. Circuit diagrams published at the time show that for the amplification of speech currents, the tube was operated from D.C. supply mains, and that such refinements as grid bias and input, as well as output, transformers were used.

Fig. 5 shows some other early soft vacuum receiving triodes dating from about 1914 to 1916, all of these having oxide-coated filaments. The "Round" receiving valve illustrated, as well as the "Round" transmitting valve shown in

Fig. 9, have pellets of asbestos sealed into extension tubes which could be heated in order to expel gas if the vacuum became too hard during use. This method of vacuum regulation was also used in the Lieben-Reisz relay, except that in this case the asbestos was replaced by an amalgam of mercury.

The year 1913 marked the introduction of the first high vacuum triodes, and a Langmuir "Pliotron" of that date is illustrated in Fig. 4. As can be seen from the illustration, the anode consists of a continuous wire suspended from glass supports on small hooks; it was heated to incandescence during evacuation. This feature can also be seen in the early Post Office repeater shown in Fig. 6. With the introduction of commercial valves of the high vacuum type, the old oxide-coated filaments were almost entirely superseded by the pure tungsten filament and by the combined oxide-coated filament, introduced about 1914 by the Western Electric Company for telephone repeater work. The development of this type of filament started with a platinum-iridium alloy and was followed by various platinum-nickel and platinum-cobalt alloys which give increased emission combined with longer life. A range of valves employing oxide-coated alloy filaments made by Standard Telephones and Cables, Limited, is shown in Fig. 7.

A parallel development of later date was the introduction of the thoriated tungsten filament which, as is well known, yields a much higher emission than pure tungsten and also has the advantage that it can be operated at a lower temperature with a consequent saving in cathode power. Valves with this type of filament are represented by many examples, some of which are quite early in date.

Fig. 6 shows some small high vacuum receiving valves, all with tungsten filaments, and note should be taken of the French "R" valve and also the French "horned" valve. The "R" valve was the first high vacuum receiving valve to be made in quantity in Europe and was used in enormous numbers during the War. It is of simple construction, having a spiral grid, the individual turns of which are not supported by any stiffening member. The undesirable effects, due to the capacity between the electrodes and between the wires in the "pinch," were observed by the French as early as 1918 when constructing amplifiers using the "R" valve for operation on the then very short wavelength of 200 metres; and the "horned" valve was probably the first attempt to overcome the difficulty. This construction went out of use for a number of years, but recent types of valve show a striking resemblance to their prototype and many valves are now produced with grid

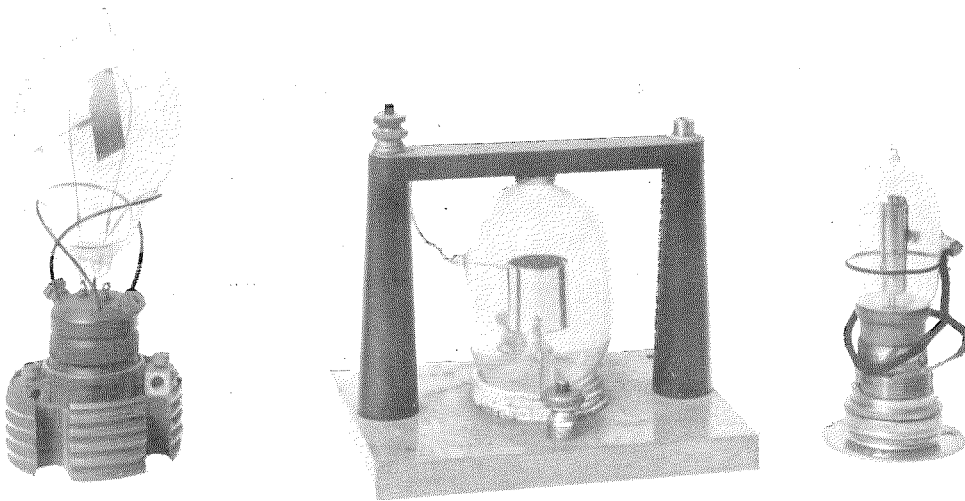

Fig. 3—Fleming Valves, 1904-1908.

and anode connections so arranged as to reduce the residual capacity.

The Telefunken valve, illustrated in Fig. 6, is a typical example of the beautiful glasswork often met with in early German valves. It will be seen that this valve has been sealed off at the top without the formation of the usual pip and closely follows the design of the French "R" valve. Earlier German valves all had flat grids and anodes placed on one side of a very small filament rather similar to the original "Audion." These valves were used in audio frequency amplifiers for earth current or power buzzer signalling and were not suitable for radio reception.

The collection includes several other early German valves, dating from about 1917, with interesting features. The employment of iron for the construction of bases, and the use of copper for anodes and grids, indicate the shortage of suitable raw materials experienced at that time. The transmitting valve shown in Fig. 9 has an iron base and part of the insulating material for the grid and filament pins is hard wood.

German valves frequently exhibit a complicated construction, with elaborate internal glasswork. The Loewe multiple valves, introduced in 1925, are worthy of mention in this respect.

Originally two types of valve were available, one comprising two radio frequency stages within one envelope, and the other a detector and two audio frequency stages, also in one envelope. The radio frequency stages were resistance-capacity coupled for aperiodic amplification, and the necessary condenser and resistances were placed inside the envelope, enabling the shortest possible connections to be used. The reduction of stray capacities thus achieved enabled valves of this type to operate satisfactorily down to about 200 metres. Very high values of anode resistance were used, of the order of one megohm, and in order to compensate for the drop in anode voltage, the valves were fitted with space charge neutralising grids.

The detector and audio frequency stages were also resistance-capacity coupled, but triodes were used in this case. Provision was made for electrostatic reaction, if required, and negative grid bias for the second electrode system was provided without the necessity of an additional battery. Using a pair of such multiple valves a

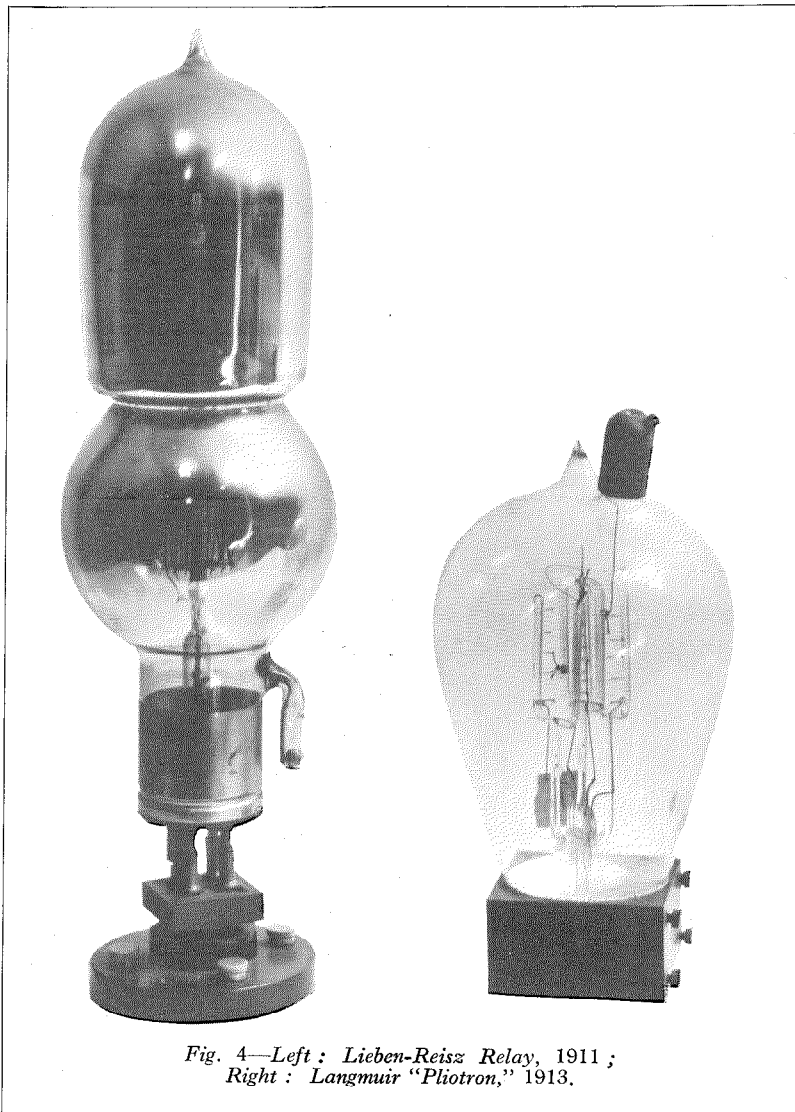

Fig. 4—Left : Lieben-Reisz Relay, 1911 ;
Right : Langmuir "Plotron," 1913.

five stage receiver could be constructed simply by the addition of tuning coils, batteries and telephones. A complete Loewe valve and two electrode assemblies are shown in Fig. 8.

Another very interesting German valve is the Schottky tetrode, also illustrated in Fig. 8. It will be noticed that the grids are of the longitudinal slat type and that all the electrodes are

securely anchored to a glass framework which is itself attached to the top of the glass bulb by means of an S-shaped glass support.

Tremendous strides have been made since those days, beginning with attempts to raise the amplification factor and mutual conductance from the then common values of about 4 to 7, and 0.5 milliampere per volt, respectively. The improved filaments referred to above, also the indirectly heated cathode, have made possible great improvements in valve performance; and the additional benefits derived from accurate

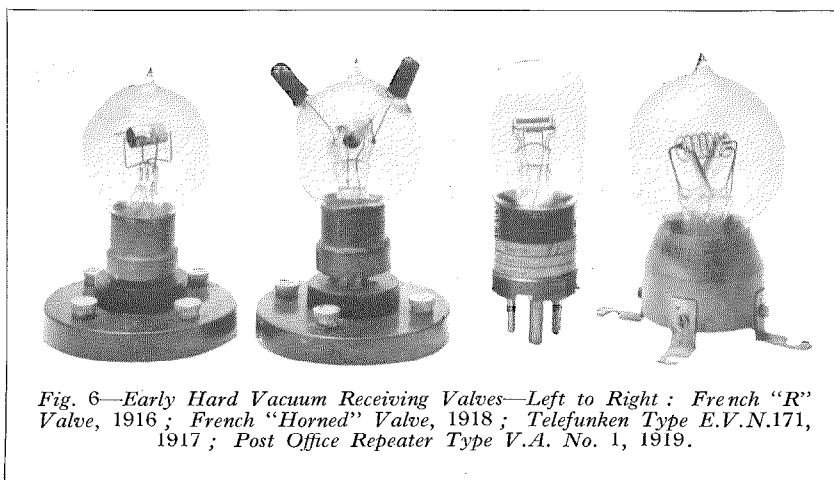

Fig. 6—Early Hard Vacuum Receiving Valves—Left to Right: French "R" Valve, 1916; French "Horned" Valve, 1918; Telefunken Type E.V.N.171, 1917; Post Office Repeater Type V.A. No. 1, 1919.

spacing of the electrodes with smaller inter-electrode distances are well illustrated in the "Micro-mesh" type of construction. Small receiving triodes are now available with amplification factors up to 100; and, in other types, mutual conductances as high as 12 milliamperes per volt are obtainable. Such constants would have seemed quite impossible of achievement fifteen, or even fewer, years ago.

Turning now to transmitting valves, three early types are shown in Fig. 9. The "Round" valve shown has no less than three separate

oxide-coated filaments and, since it is of the soft vacuum type, it can be assumed that filament life was not very long. The Telefunken valve illustrated has a grid wound with very fine wire on a glass framework which was a fairly common feature of many of the early types such as the "Plotron," "Oscillion," etc. Perhaps the chief trend in design has been in connection with the production of valves suitable for higher and higher power, and a number of examples in the collection make it easy to trace the gradual evolution of the present-day types. An early attempt

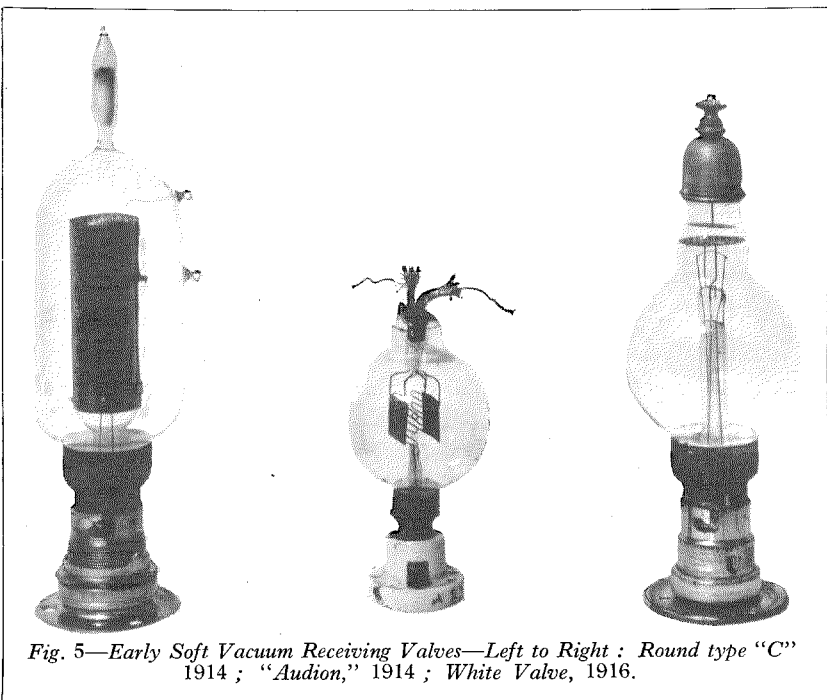

Fig. 5—Early Soft Vacuum Receiving Valves—Left to Right: Round type "C" 1914; "Audion," 1914; White Valve, 1916.

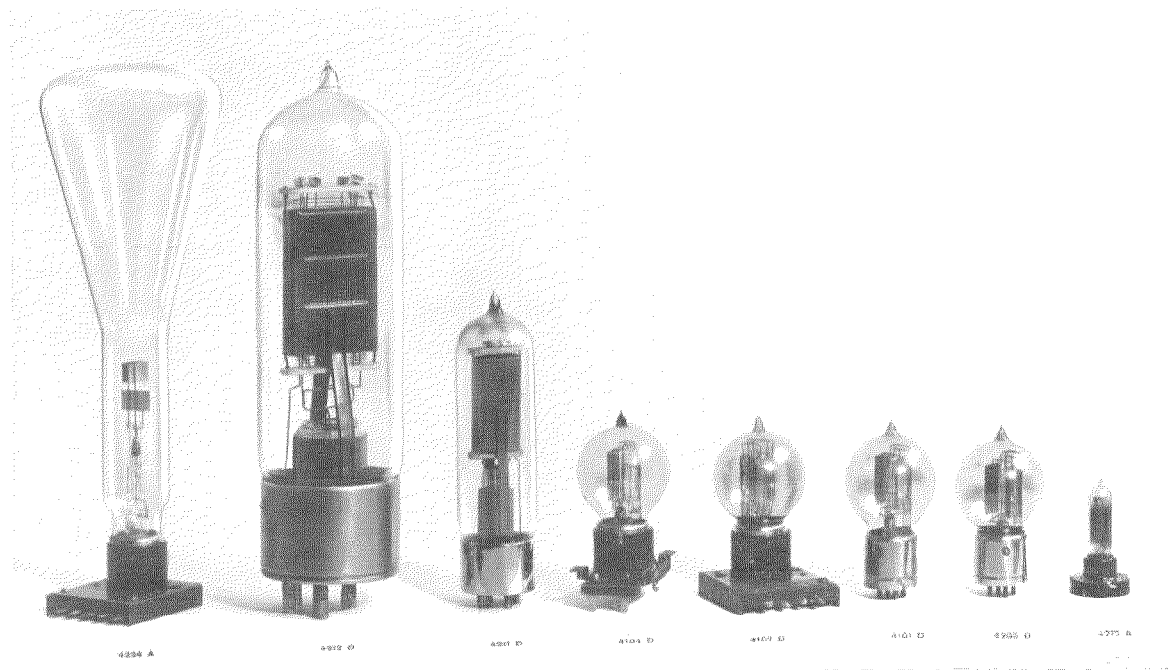

Fig. 7—A Range of Oxide-coated Alloy Filament Valves made by Standard Telephones and Cables, Limited.

to increase heat radiation from the anode is clearly visible in a Marconi-Osram type T-2-A of 1917 which has a corrugated cylindrical anode, the projections being the forerunners of the modern radiating fins.

Subsequent development indicates the use of black or rough finishes to the anode, such as oxidised or carbonised nickel, sandblasted surfaces and also the use of materials such as molybdenum and graphite which are suitable for operation at higher temperatures.

At the same time, the gradual introduction of hard glasses can be noticed and also the use of tungsten and molybdenum leads instead of the early platinum and alloy wires, enabling the dimensions of the envelope to be considerably reduced. The limit of size for ordinary glass valves was quite early found to be of the order of 2 kilowatts anode dissipation, but anode dissipations up to 10 kilowatts were found to be possible with valves having fused silica envelopes, which were produced, after some initial manufacturing difficulties, in 1919. A small valve of this type is shown in Fig. 10, and it will be seen that the anode is woven from

narrow strip on account of the difficulty of working molybdenum sheet.

The design of the seals for the silica valves, which must be capable of carrying relatively large currents, is somewhat unusual. The actual sealing material is lead and, since valves are heated in an oven to a temperature of 1 000°C. during manufacture, it is necessary to provide the long sealing tubes shown, as well as an extension tube containing the filament spring, so that these may project from the oven during the baking process and be cooled by blasts of air. Silica valves are accordingly provided with forced ventilation during use. Two large valves, a diode and a triode, can be seen in their special cages in Fig. 2. These cages serve not only to support and protect the valve, but also to confine and direct the airblast from the blowers.

One of the most important steps in the evolution of the high power valve was the House-keeper copper-glass seal, which made the construction of large, sealed-off, water-cooled valves with copper anodes a commercial proposition.

Previously, it was customary in high power

transmitters to connect in parallel large numbers of glass valves, as many as 500 valves having been used in some instances.

With the water-cooled valve, powers up to 100 kilowatts were soon found to be practicable with only a single valve. An interesting outcome of the copper-glass seal was the production in England, in 1933, of the "Catkin" type of receiving valve. These valves have air-cooled copper anodes, only a small proportion of glass being used in their construction. The conventional type of flat glass "pinch" is done away with, the leads being brought out through a circular seal.

Another development of great interest in connec-

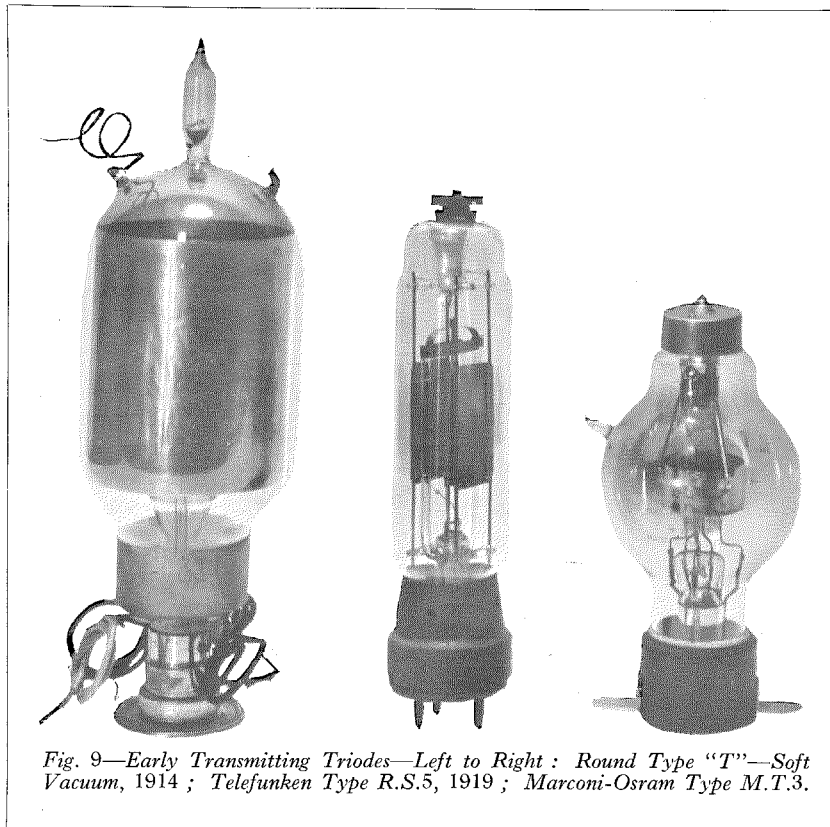

Fig. 9—Early Transmitting Triodes—Left to Right : Round Type "T"—Soft Vacuum, 1914 ; Telefunken Type R.S.5, 1919 ; Marconi-Osram Type M.T.3.

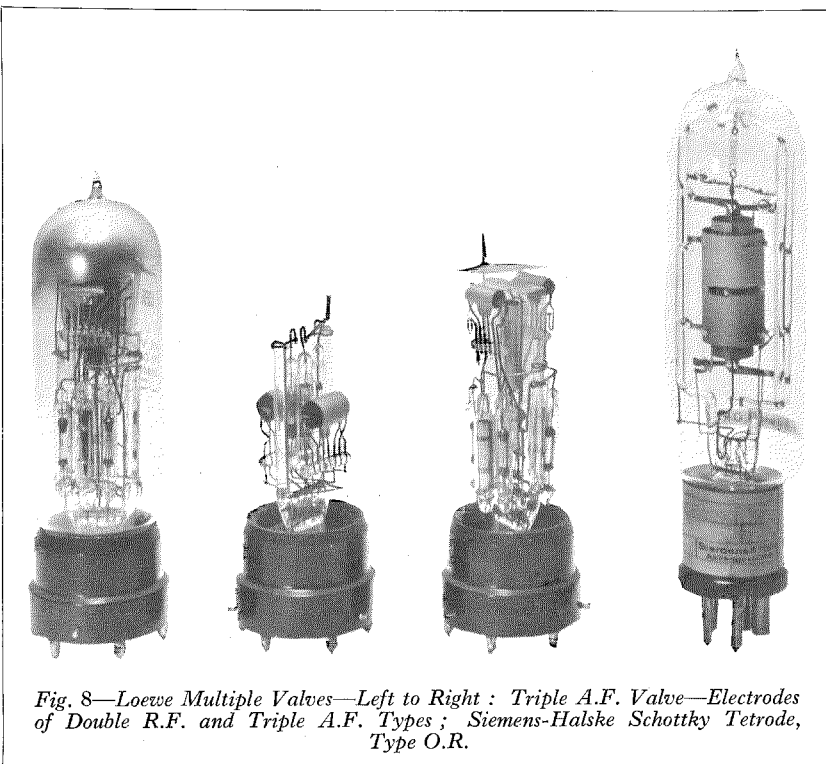

Fig. 8—Loewe Multiple Valves—Left to Right : Triple A.F. Valve—Electrodes of Double R.F. and Triple A.F. Types ; Siemens-Halske Schottky Tetrode, Type O.R.

tion with receiving valves is the "All Metal" valve introduced by the Radio Corporation of America in 1935. The design is a radical departure from orthodox methods inasmuch as the glass envelope is replaced by a steel shell with large spot-welded vacuum-tight joints. The valves are evacuated by means of a copper tube, also sealed by welding, and the only glass used in the entire construction is in the form of small beads, one bead being employed to seal each lead.

The tendency towards the abolition of the glass envelope would make an interesting historical survey in itself, and it is

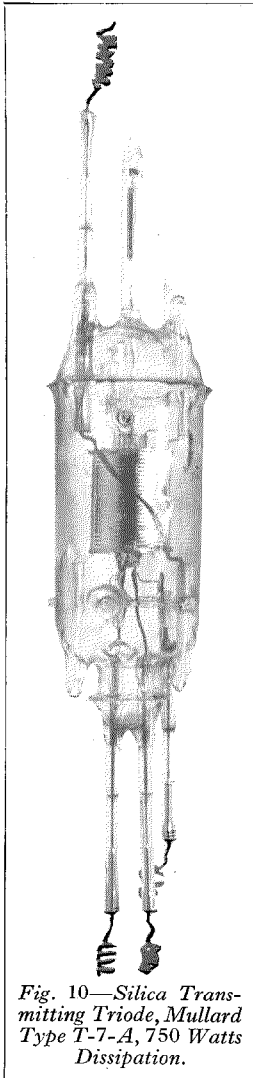

Fig. 10—Silica Transmitting Triode, Mullard Type T-7-A, 750 Watts Dissipation.

worthy of note, in passing, that Lodge took the first step by constructing and using an "all metal" X-ray tube so long ago as 1896.

Having produced valves capable of handling high powers, the designer next turned his attention to valves for use on high frequencies, the resultant valves being, in some cases, very similar to the old French horned valve. A few valves of this type are shown in Fig. 12. The stage has now been reached that makes a reduction in physical dimensions imperative, the Western Electric 316-A and Standard Telephones & Cables type 4316-A (Fig. 11) being examples of this modern trend. Reduction in size has also been found advantageous in valves designed for reception at very high frequencies, the well-known "Acorn" type being an example

of such technique. That specially small receiving valves are not entirely new can be appreciated from an Ediswan type D-2-X, made in 1918, believed to have been used as a detector in receivers designed for the then extremely short wave-length of 50 metres. This valve, which is only $1\frac{1}{4}$ inches in length, $\frac{5}{8}$ inch in diameter and of double-ended construction, clearly indicates that the designer was familiar with the problems which still remain to be considered to-day. The electrodes consist of three fine parallel wires located in one plane.

For the very highest frequencies, normal tubes and conventional methods of operation fail entirely and the problem of the generation of

micro-rays, as they are frequently called, must be tackled by other methods.

Three types of these special tubes are included in the collection, namely, the split anode magnetron, the Marconi-Mathieu tube and the micro-ray tube of Standard Telephones & Cables.

Split anode magnetrons, though they have received a great deal of attention in the laboratory, do not appear to have been used commercially for the purpose of communication as they cannot be modulated conveniently.

The Marconi-Mathieu tubes are triodes of the positive grid type and are used in a special symmetrical circuit necessitating a pair of valves, each of which is constructed as the mirror image of the other. An output of about 3.5 watts can be obtained from a pair of tubes on the normal wavelength of 60 cm.

The Standard Telephones & Cables micro-ray tube (Fig. 13) also operates with a positive grid and negative plate but is entirely different in principle. Both ends of the grid are brought out to the top of the tube and these leads alone are connected to the transmission line. The wavelength generated is primarily dependent upon the geometry of the tube and is usually of the order of 16 cm.

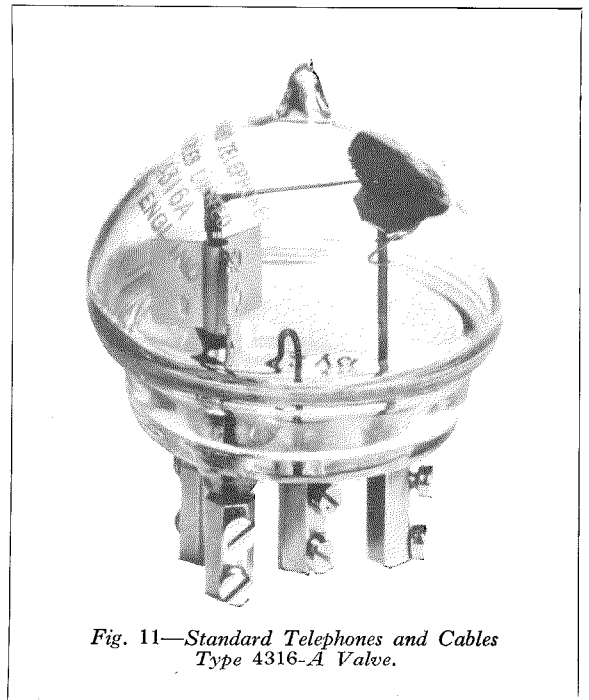

Fig. 11—Standard Telephones and Cables Type 4316-A Valve.

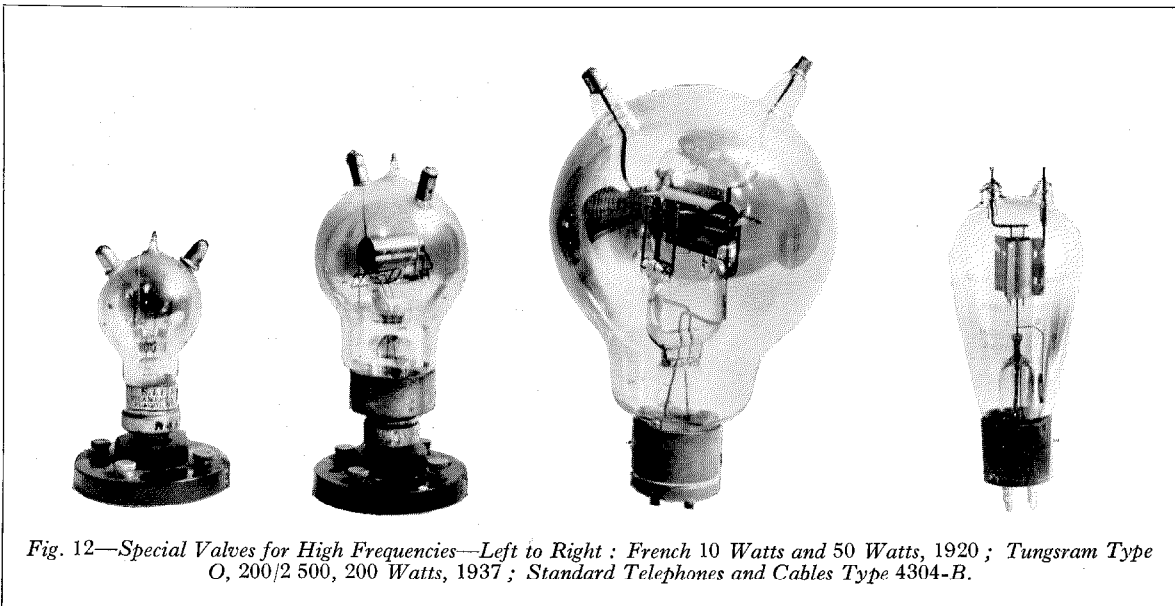

Fig. 12—Special Valves for High Frequencies—Left to Right : French 10 Watts and 50 Watts, 1920 ; Tungram Type O, 200/2 500, 200 Watts, 1937 ; Standard Telephones and Cables Type 4304-B.

These extremely short waves, being quasi-optical in behaviour, are usually concentrated in narrow and highly directional beams by means of parabolic reflectors. Such methods enable reliable commercial links to be established over distances up to about 30 miles.

Photo-Electric Cells

Photo-electric cells in the museum, including a modern electrolytic cell, comprise a small group, taking one back almost a century to the discovery of the Becquerel effect ; selenium cells depending on May's discovery in 1873 ; and the later thick film cells with cathodes of sodium, potassium, rubidium and caesium. Several of these cells have points of special interest, in particular one rubidium cell which is one of the first two cells of this type constructed in England. Two particularly large cells can be seen in Fig. 1, that on the right being a potassium cell measuring about 12 inches in diameter. Both of these cells were used in early systems of low definition television. A number of examples of the modern thin film cells are also included, together with the so-called barrier layer cell and the selenium-iron self-generating cell.

Cathode-Ray Tubes

A section of the collection is devoted to the cathode-ray tube and its development ; and,

although the number of specimens is not great, the most important types of low voltage tubes are all shown.

The Braun tube of 1897 is represented by a reproduction, as genuine tubes of such an age are almost non-existent. A very interesting tube of the same period is the Perrin tube. This is not an oscillograph tube, but is of the type used by Perrin in 1895 in his experiments which showed for the first time that a beam of cathode-rays carries a negative charge.

Another interesting cold cathode tube is one made by Cossor in 1903 with silver deposited on the interior of the bulb, exactly as a conducting layer of graphite is used in tubes of the present day. An early tube of about 1908 has a Wehnelt oxide-coated cathode consisting of a spot of lime on a platinum ribbon ; and another tube of 1918 has a Coolidge type cathode with adjustable hood to assist the focussing of the electron beam. All the above examples have the fluorescent material on a flat mica plate within the glass bulb and not actually on the surface of the glass envelope as is now universal.

These old tubes were very unreliable in operation and the hot cathode types all had very short lives as the vacuum was always poor. The remains of a very interesting tube of 1910 are worthy of note in this connection, inasmuch as this tube had the unusual feature of being demountable for ready renewal of the cathode

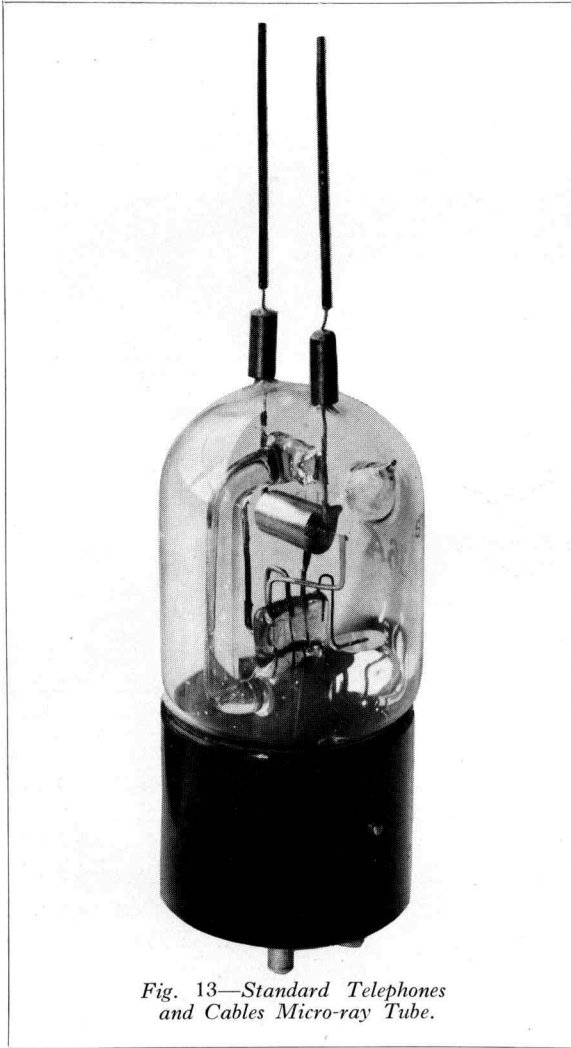

Fig. 13—Standard Telephones
and Cables Micro-ray Tube.

and fluorescent screen. The latter was formed on a flat glass plate cemented to the body of the tube, and the Wehnelt type cathode was supported by an adjustable mount to facilitate correct alignment of the lime spot with the aperture in the anode. The tube was continuously evacuated and was fitted with an osmosis vacuum regulator; unfortunately, the adjustable cathode assembly is now missing.

It needs no great stretch of imagination to appreciate that all these early tubes were very difficult to manage satisfactorily, and considerable skill was required to coax them into operation. When they were working, the size of the trace frequently left much to be desired and their behaviour during use was anything but stable. The subsidiary apparatus usually consisted of a motor-driven Wimshurst machine for the high tension supply and bulky focussing coils consuming a considerable amount of power.

The first satisfactory tube from a commercial standpoint was the Western Electric type 224-A of 1921 operating on low voltages and without the need of magnetic focussing. A further range of tubes shows some of the stages in the development of the hard vacuum oscillograph as it is known to-day, concluding with the modern large screen tubes for the reception of television and also experimental high voltage projection tubes. Some of these tubes can be seen in Fig. 1.

Conclusion

The preceding short description is the merest outline of the field covered by the entire collection. To deal with the very numerous minor improvements and developments, which have all played some part in perfecting the older types of apparatus, would be impossible. The museum serves to bring to mind the fact that the evolution of electronic apparatus has been in progress longer than is usually appreciated and that the latest and most complicated developments, such as television, are based upon fundamental discoveries made many years ago.

In conclusion, the writer would like to add that the collection, though private, is available for inspection by appointment and that visitors are always welcome.

Editor's Note : Mr. Weston's address is : "Oakwood,"
The Chase, Reigate, Surrey.

7-D Rotary Exchanges in Rumania

By JACQUE TER SARKISSOFF, A.I.A.M.,

Switching Systems Operating Superintendent,

and

L. B. TUCKER,

Plant Manager,

Societatea Anonimă Română de Telefoane, Bucharest, Rumania

INTRODUCTION

IT was in the year 1935 that the engineers of the Bell Telephone Manufacturing Company produced their first designs for automatic equipment for small communities. Compared with the facilities required to-day, these early designs were relatively simple and, in the intervening years, the equipment has gradually developed from small single office exchanges suitable for isolated villages to the present conception of complete networks including 60 or more exchanges and even extending to complete national systems.

At the end of the year 1937, 167 000 lines of the 7-D Rotary System were installed or on order, spread over 535 different exchanges in all parts of the world.

The system has been described in previous issues of *Electrical Communication*.^{*} The present article describes the most recent developments and also shows how the system is ideally constituted to meet the requirements of the provincial towns of Rumania.

PRESENT INSTALLATION PROGRAMME

When the present installation programme of the Societatea Anonimă Română de Telefoane is completed, Rumania will have eighteen automatic offices in the seventeen cities indicated in Fig. 1. The greater number will be of the latest 7-D Rotary type, incorporating several new and highly advantageous features.

The first of the new type of 7-D exchange, with 1 000 lines, was cut into service in Iasi in December, 1936. An extension of 400 lines was added in 1937.

Exchanges in five more cities, Arad with

1 800 lines, Cluj with 2 800 lines, Galați with 1 800 lines, Brăila with 1 200 lines and Craiova with 1 000 lines, were placed in service in 1937.

This year (1938) installations of the new 7-D type equipment have been successfully placed in operation in Constanța (2 000 lines), Oradea (2 600 lines), and Timișoara (3 600 lines). Work on Chișinău (1 200 lines) and Cernăuți (2 800 lines) is nearing completion.

A 3 000 line 7-D installation at Brașov is scheduled for completion in 1939. Conversion to 7-D in Satu Mare and Sibiu will follow in 1940 or shortly thereafter (see table, page 150).

Installation is handled by the Plant Department of the Societatea Anonimă Română de Telefoane in close co-operation with the engineers of the Bell Telephone Company, Antwerp, manufacturers of the equipment.

CHOICE OF SYSTEM

The new type 7-D (Urban) Rotary Switching System was chosen for the Rumanian programme inasmuch as the improvements and added facilities incorporated therein made it the most suitable for meeting the local conditions.

Primarily, the 7-D system was developed to meet the telephone switching requirements of a small or medium sized, but complete, urban area.

The great flexibility of this system permits operation as a single and separate unit or (without modification of the equipment) as an integral part of a multi-office scheme, either with or without satellite exchanges.

The design of the 7-D system as installed in Rumania basically follows the general principles of the 7-A Rotary system. The chief innovations are the use of single motion switches

^{*} See in particular, "The 7-D Rotary Automatic Telephone System," by W. Hatton and J. Kruithof, *Electrical Communication*, April, 1935.

throughout (no two-motion switches are included) and the introduction of partial combined line finder and finals.

Distinctive and interesting features may be summarised as follows :

- (1) Reduced floor space requirements ;
- (2) Uniformity of equipment due to the single motion switch (the same type of mechanism is used for finders as for selectors) ;
- (3) Increased flexibility of outlets for selection ;
- (4) Increased facilities for miscellaneous services ;
- (5) Automatic routine testing scheme ;
- (6) Introduction of overflow arrangements :
 - (a) on penultimate group selectors,
 - (b) partial combined 1st line finders and final selectors, and
 - (c) team switched register groups ;
- (7) Simplified alarm scheme ;
- (8) Extended service observing facilities ;
- (9) Direct reading traffic recording ;
- (10) Universal register ;
- (11) Reduced current consumption ;
- (12) Simplicity of installation ;
- (13) Completely unattended night service ;
- (14) Low maintenance ;
- (15) High operating efficiency.

Each one of these points will be considered in detail.

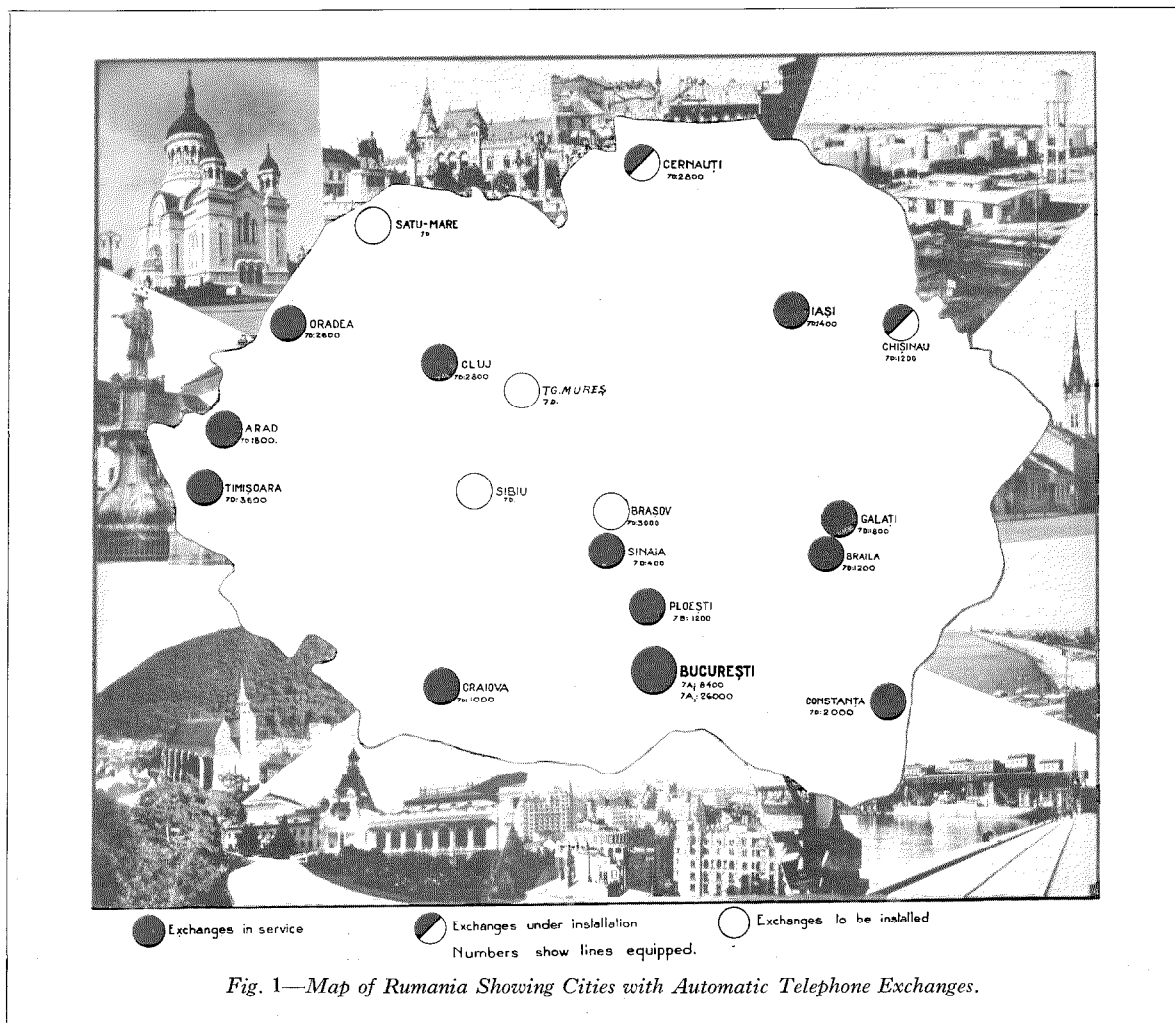

Fig. 1—Map of Rumania Showing Cities with Automatic Telephone Exchanges.

REDUCED FLOOR SPACE REQUIREMENTS

Ideal floor-plan lay-outs have been achieved due to the fact that in each city new buildings were erected for housing the equipment (Figs. 2 and 3). With the exception of the Timișoara and Cernăuți exchanges, where separate floors are provided for automatic and toll equipment, all the buildings are laid out on practically the same plan for an ultimate of 5 000 to 6 000 lines of automatic and accessory equipment. Each building consists of a basement, ground floor and first floor. Commercial and public offices (Fig. 4), together with the toll board, occupy the ground floor. All automatic equipment, together with main frames, toll, carrier and repeater equipment, local and toll test desks are located on the first floor. In most of the offices, power boards and charging machines, ringing generators, etc., are also on the first floor, batteries being placed in the basement.

The units and bays mounted on the switch-racks, as illustrated by Figs. 5 and 6, are of a remarkably simple, clear-cut, uniform and compact design. As a result, the floor space occupied by the automatic equipment of the 7-D Urban exchange has been reduced to about 0.02 m² per line, for a traffic rate of 1.7 EBHC (equated busy hour call).

SINGLE MOTION SWITCH

This switch is of simple construction and its adoption as a finder and a selector made practicable the introduction of the partial combined line finder and finals. These innovations, taken together, resulted in the above mentioned greatly improved equipment.

Since the mechanical construction of the selector is exactly the same as the finder, the number of different piece parts is reduced considerably. Smaller stocks of replacement

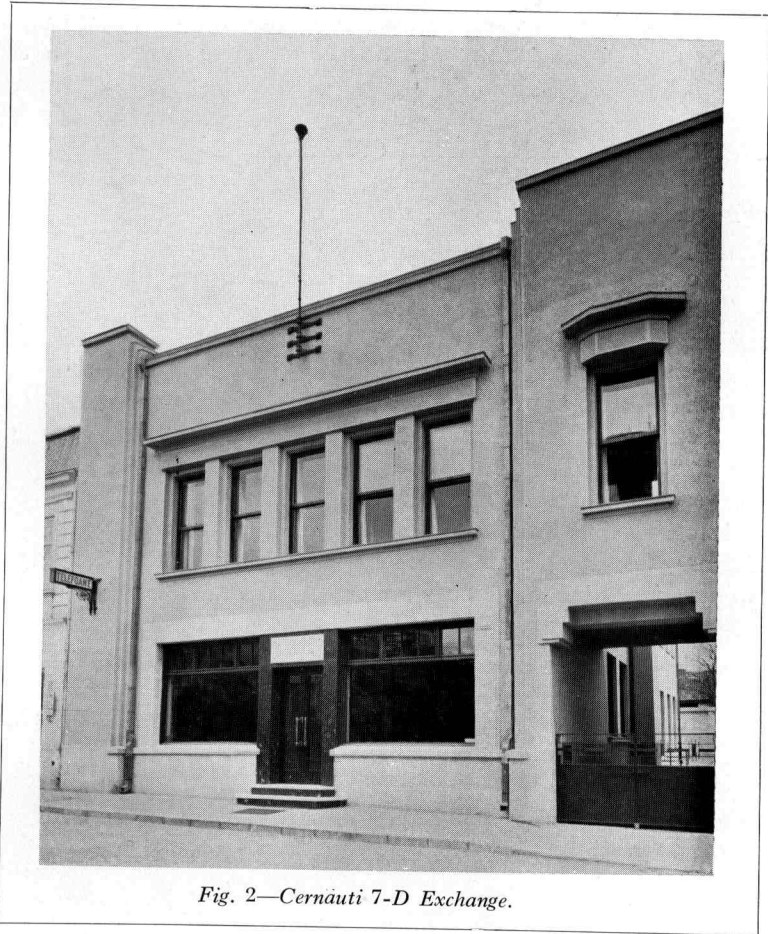

Fig. 2—Cernăuți 7-D Exchange.

parts are thus required, and the maintenance staff has one less type of switch to deal with.

INCREASED FLEXIBILITY OF OUTLETS FOR SELECTION

All selection is accomplished by the single motion finder type switches. They are designated as first group selector, penultimate group selector and final selector, respectively.

Operation at each stage is the same in principle, and the flexibility of outlets ensures an optimum trunk efficiency for each direction. For example, the 100 points of the arc can be sub-divided into 10 directions of 10 outlets each; 5 directions of 20 outlets each; 2 directions of 50 outlets each; or 3 directions of 20 outlets each, plus 4 directions of 10 outlets each. The ratio of outlets to directions can be changed as traffic conditions may dictate. Full advantage of this feature is taken in the latest type of 7-D exchange.

Group selectors continue hunting when all outlets are busy, a feature which is common to all rotary systems.

INCREASED FACILITIES ON MISCELLANEOUS SERVICE

Miscellaneous services have been highly developed in this new 7-D exchange.

Two party line service with revertive calling facilities may be given on any line in the exchange, without any special additional apparatus, by making a simple change in the wiring. Common revertive call circuits are connected to the special service 2nd group selectors.

A special changed number circuit may be connected to any line. If a subscriber's number is changed, his old number is jumpered to this circuit and all incoming calls are directed to the information operators.

An adapter circuit makes it possible to convert any line to automatic pay station service.

Merely a single wire strap is required to convert any regular line into a P.B.X. line or a dead line.

A new tone distributing scheme has been introduced. Tone is given from the penultimate group selectors and requires less equipment than when given from the final selector circuits.

False calls are automatically indicated on the local test desk. They can be taken care of immediately by the attendant who, if necessary, can connect his howler circuit.

Delayed back release, after a predetermined period, frees a called subscriber who has hung up, even if the calling subscriber does not do so. The calling subscriber's connected line subsequently is signalled as a false call.

A simple malicious call circuit was developed in Rumania, in collaboration with the Bell Telephone Manufacturing Company's engineers, to meet the demand from subscribers for this service. If a subscriber receives malicious calls, he requests the Telephone Company to connect him to the malicious call circuit. When he thereafter receives a call which he finds to be malicious, he depresses his switch hook or cradle momentarily, whereupon the line originating the malicious call is blocked and a signal is given to the exchange attendant, who can proceed to identify the calling subscriber.

In the larger offices, manual testing of subscribers' lines by the Wire Chief is performed over a test train. To test on a line, he plugs up one of the special trunks provided for the purpose and dials the subscriber's number. Connection is established through a special register and test group selector to a predetermined final selector. Although this selector is available to the Wire Chief, it functions as a normal final selector when not occupied for testing purposes, and is suitable for ordinary subscriber-to-subscriber calls.

AUTOMATIC ROUTINE TEST SCHEME

For each type of main circuit, an automatic routine test circuit is provided. Each main



Fig. 3—Galati 7-D Exchange.

circuit can be tested individually, by connecting it to this test circuit, or all main circuits can be tested automatically in a definite sequence (progressive test). To start the test, a key is depressed. When attended, an alarm is rung on a fault encountered. Unattended operation with a printer is possible, in which case indication of a faulty circuit is given on the printer tape, whereupon the following circuit is tested.

Before leaving at night, the attendant can throw the keys of the routine test circuits associated with the circuits to be tested. In the morning, he can note from the printer tape any circuit which is not functioning correctly and which requires further testing to detect the specific fault.

Penultimate, 2nd group and final selectors are tested from the preceding circuits over their normal multiple. For instance, the penultimate group selector is tested from the arc of the 1st group selector. Not only is the circuit itself thus tested, but the multiple is also checked.

INTRODUCTION OF OVERFLOW ARRANGEMENTS

(a) Penultimate Group Selectors

Overflow group selectors are connected in the arc of the penultimate group selector. These selectors operate only when the hunting 1st group selectors find all the sub-divisional outlets to the wanted penultimate group occupied. Then an overflow relay operating in the 1st group control allows selection (in addition to the correct group) of the next group of outlets in the arc of the 1st group selector. The latter group, however, corresponds to a different 1 000's figure and the overflowing call is thus directed, by the "wrong" penultimate group selector, to an overflow

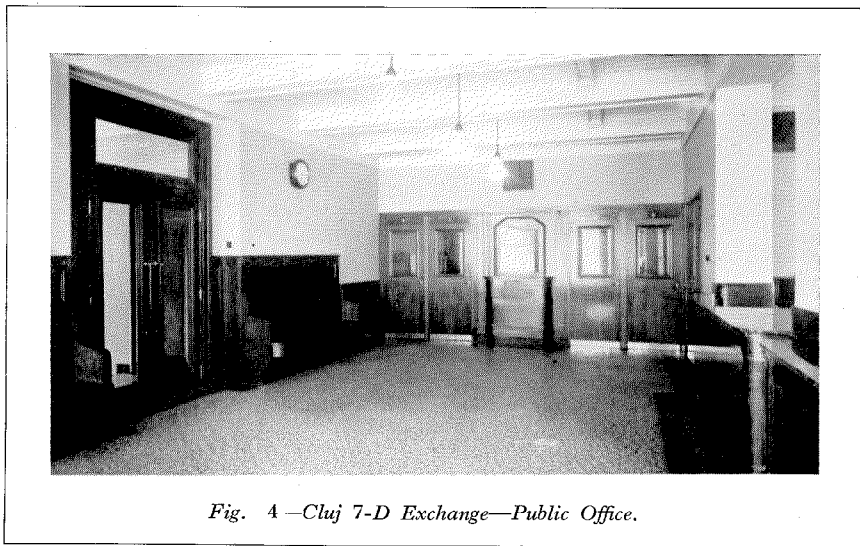

Fig. 4—Cluj 7-D Exchange—Public Office.

group selector which transfers the call to the correct final group.

In effect the overflow group selector improves the efficiency of the penultimate group selectors by increasing the number of 1st group selector outlets for a given case and by distributing the traffic uniformly, resulting in economy of equipment.

(b) Partial Combined Line Finder and Final Selectors

This innovation, which is peculiar to the 7-D Urban system, takes advantage of the fact that the 1st line finder and the final selector are machines of the same type and operate in the same multiple. Each subscriber's line group is provided with a certain number of straight 1st line finders, straight final selectors and some combined machines for use either as final selector or first line finder as the traffic demands. All these machines are in the same bay.

The combined 1st line finder and finals are only engaged if, on originating calls, all straight 1st line finders are busy and if, on terminating calls, all straight final selectors are found busy by the hunting penultimate selector.

Through the use of these combined machines, the operating efficiency of both the finals and the finders is greatly increased. Traffic peaks in one or the other portion of the equipment are taken care of. Fewer machines are able to handle more traffic than could straight machines

only, due to the confluence of originating and terminating traffic. The straight switches carry 80 to 95% of the total traffic.

(c) Team Switched Register Groups

This arrangement is introduced to increase the efficiency of the registers, if they exceed one group.

All the link circuits connected to the link finder arcs are multiplied to the team switches of the same register group. A call arriving at a particular group, where no registers are free, starts all free registers of the other groups to hunt with their link finders for free team switches of this particular group. The team switches of one group appear in the link finder arc multiples of the other groups. The call is, therefore, handled by a free register of another group.

ALARM SCHEME

In addition to the usual alarms indicating power failure, disturbance in tone leads, blown fuses, etc., indication is also given for false

calls, malicious calls, and registers or control circuits blocked or held.

Traffic overloads are signalled when all the machines, or control circuits, belonging to the same type of circuit are occupied. On hearing this alarm, the attendant immediately inspects the equipment involved in order to determine whether machines are being held through incorrect subscriber operation or an easily clearable fault. In such cases, he may be able to restore a machine to service immediately and relieve the traffic congestion.

SERVICE OBSERVING FACILITIES

Each exchange includes a service observation board with complete facilities for observing calls direct from subscriber to subscriber. Groups of subscribers are connected to this circuit, and service observations may be made by group or individually. Important data on subscriber usage, holding time, etc., is thus collected.

A printing recorder facilitates the taking

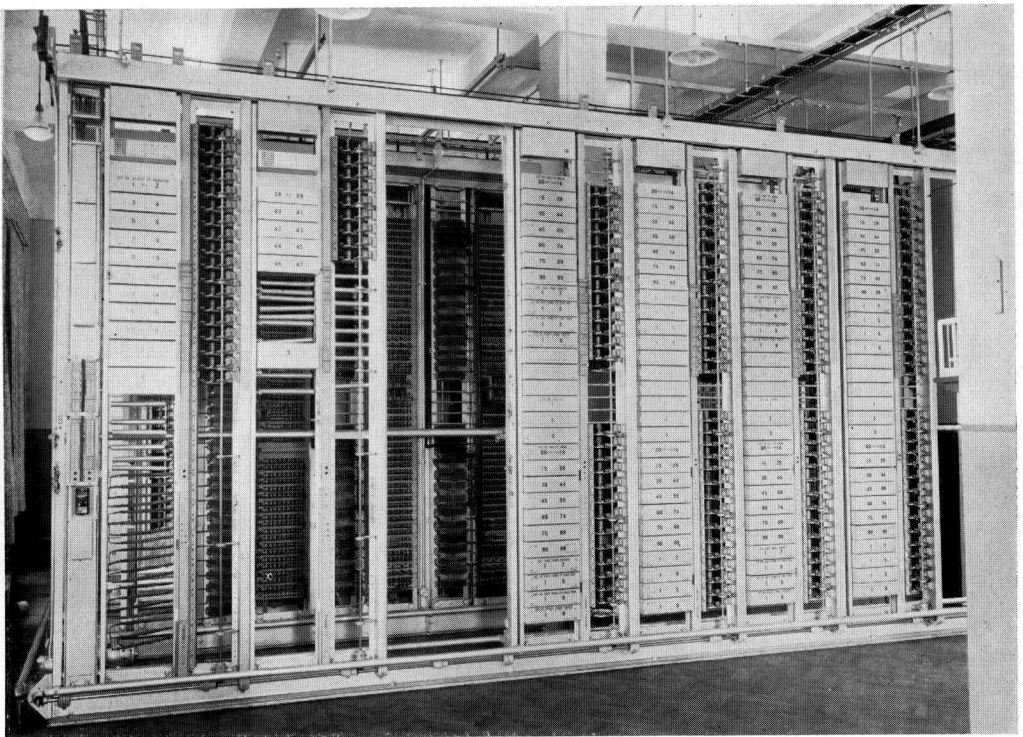

Fig. 5—Galati 7-D Exchange—1st Line Finders, Final Selectors and Penultimate Group Selectors.

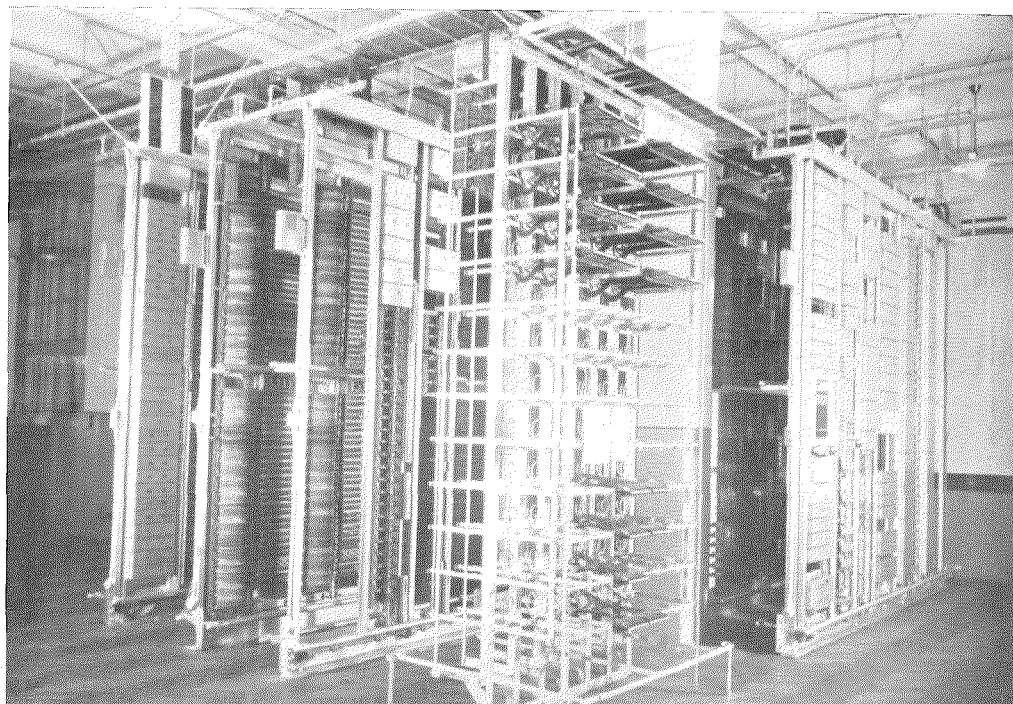

Fig. 6—Arad 7-D Exchange—Distributing Frame and Automatic Equipment.

down of the desired information; reading from it is much easier than from an inked tape. This recorder prints the number of the called subscriber, the time of making a call and its duration.

DIRECT READING TRAFFIC RECORDING

Complementary to the service observation board, direct reading traffic recording equipment is incorporated in each 7-D Urban exchange.

The object of traffic recording is to determine the traffic load on the various groups of switches, so as to enable the anticipated traffic to be compared with the traffic which the equipment is actually carrying during the busy hours.

In order to give a first class service at all times and to utilise the equipment to its maximum efficiency, it is of primary importance to determine the traffic of the various groups of equipment at frequent intervals. Redistribution of the load or the addition of equipment before traffic congestion takes place is thus made practicable.

The traffic is recorded on a comparatively few meters. Since the recording equipment is started by a master key and stopped automatically, the readings can be taken when convenient by a single person.

Traffic calculations for the Rotary systems are based on a unit commonly known as EBHC (equated busy hour call). This unit represents a call with an average holding time of two minutes.

Outstanding features of the Rotary direct reading traffic recording equipment include :

Direct reading in EBHC and BHC per group of switches or circuits.

Direct comparison between expected and actual traffic (in EBHC) without the necessity of elaborate calculation.

The traffic of all switch groups in the exchange can be measured simultaneously.

The condition of each circuit is checked individually; therefore, simultaneous metering is avoided.

The recording equipment is prepared by

depressing a few keys located on the recording bays.

The equipment can be operated by an unskilled person and no supervision is required during the recording period.

The following information may be obtained with the direct traffic recording equipment:

- Originating traffic per group,
 - Terminating traffic per group,
 - Total local traffic,
 - Total outgoing traffic per direction,
 - Total register traffic,
 - Holding time for different circuits.
- The Rotary traffic recording equipment is

advance, are arranged to meet practically all future service requirements without extensive modification.

Provision is made for open and closed numbering, restricted and non-restricted service, long distance dialling, satellite and multi-office operation, multi-metering and timed service, additional digits, the introduction of automatic rural offices, etc.

The same register is used for both toll and local service.

REDUCED CURRENT CONSUMPTION

All circuits are designed for minimum current

TABLE OF RUMANIAN AUTOMATIC EXCHANGES

City	Population	System	Initial Installation Lines Equipped	Date of Cut-Over	Present Installation Lines Equipped	Lines Connected July 31st, 1938	Total Max. B.H.C. Read on Registers	Corresponding Amperes Max. Current Drain	Stations	Stations per Line Connected
Bucharest	630 000	7-A1	3 600	1927	8 400	8 388	18 000	310	10 454	1.3
		7-A2	12 000	4.11.33	26 000	20 861	70 000	870	32 057	1.5
Ploesti	80 000	7-B	600	16. 4.32	1 700	1 321	2 300	70	2 320	1.7
Sinaia	6 000	7-D	200	17. 6.34	400	333	480	15	588	1.7
Iasi	102 000	ditto	1 000	19.12.36	1 400	1 082	3 200	60	1 519	1.5
Arad	77 000	"	1 200	22. 4.37	1 800	1 211	3 000	60	1 486	1.2
Cluj	98 000	"	2 000	28. 5.37	2 800	2 087	5 600	110	2 666	1.3
Galati	101 000	"	1 800	29. 7.37	1 800	1 181	4 100	60	1 506	1.3
Braila	68 000	"	1 200	25. 9.37	1 200	902	2 600	45	1 130	1.1
Craiova	63 000	"	1 000	29.10.37	1 000	823	1 900	40	1 112	1.2
Constanța	58 000	"	2 000	8. 4.38	2 000	1 154	2 500	50	1 468	1.3
Oradea	82 000	"	2 600	20. 4.38	2 600	1 431	5 600	110	1 874	1.3
Timișoara	92 000	"	3 600	29. 7.38	3 600	2 582	9 000	145	3 376	1.3
Cernăuți	111 000	"	2 800	1938	—	—	—	—	1 879	—
Chișinău	117 000	"	1 200	"	—	—	—	—	835	—
Brașov	59 000	"	3 000	1939	—	—	—	—	1 860	—
Satu Mare	50 000	"	—	—	—	—	—	—	705	—
Sibiu	48 000	"	—	—	—	—	—	—	836	—

based on the principle of repeatedly measuring the number of circuits simultaneously engaged.

As traffic calculations are based on the average of a large number of busy hour loads, it is quite possible that the equipment may show signs of overload for short periods. This is permissible as it would not be economical to supply equipment to meet the maximum peak load encountered in a few abnormal busy hours during the year.

UNIVERSAL REGISTER CIRCUIT

All registers, as far as can be determined in

consumption during the conversation period. The number of switch-rack motors is minimised by coupling as many as five rows, representing a 35 metre rack-length, to a common drive. The resulting economy in power consumption reacts favourably on the size of the charging equipment and batteries.

SIMPLICITY OF INSTALLATION

The first of the 7-D exchanges of the present programme, it is interesting to note, was inaugurated within six weeks from the time of arrival of the first bays. Such speedy accom-

plishment is in itself a clear indication of the simplicity and ease of installation.

Other than forming out and connecting the inter-bay cable, very little wiring is necessary on the bays proper. Even miscellaneous apparatus is furnished in convenient units which usually merely require mounting on the rack and connecting to the cable.

Estimates of installation time, prepared on the basis of prior experience, have been halved in some instances.

UNATTENDED NIGHT SERVICE

In Rumania, 7-D exchanges are left completely unattended during the slack hours and throughout the night. Where recording printers are available, the attendant before leaving in the evening throws the start keys for the routine circuit checking. The next morning the printer tape is read and any faults disclosed are cleared before the hours of heavy traffic commence.

LOW MAINTENANCE

Uniform equipment, single motion switches, universal registers and the complete alarm scheme previously described, obviously make for easy maintenance. Automatic routine testing cuts down further the effort necessary to keep the exchanges in good condition. Surprisingly little "man power" is required. Since the toll test desk, carrier and repeater equipment is located on the same floor as the automatic equipment, personnel may be used for the maintenance of both local and toll equipment. Moreover, long line open wire carrier circuits are included extensively in the Rumanian network; and the office lay-out is well adapted to the joint maintenance of automatic and toll

equipment, thus keeping the total maintenance force at a minimum.

HIGH OPERATING EFFICIENCY

The previously mentioned simplifications and new features obviously contribute towards a very high operating efficiency.

Service observations on the 7-D Rumanian equipment show an overall operating efficiency consistently better than normal expectancy, with unfavourable equipment reactions at an unusually low figure.

Iasi, the first 7-D rotary switching exchange of the Urban type installed, operated for the first six months with an average of 990 lines connected out of a possible 1 000. The subscribers, within a short period after cut-over, accustomed themselves to dialling. The automatic equipment fully met expectations and, notwithstanding the immediate peak load, gave fast and accurate service over the entire period prior to the installation of additional equipment.

No other 7-D exchanges have been subjected to such a severe test from the start. There is, nevertheless, every reason to believe that they would function equally well.

CONCLUSION

The 7-D Urban exchanges, with the several innovations and improvements incorporated therein, have demonstrated their importance in enabling the S. A. R. de T. to furnish its subscribers with a highly reliable, speedy and comprehensive telephone service. These exchanges, moreover, provide a system which is extremely economical, as well as easy to maintain, and which more than meets the requirements imposed on a modern urban automatic telephone network.



TAKESABURO AKIYAMA (1873-1938)

TAKESABURO AKIYAMA, Chairman of the Board of Directors of the Nippon Electric Company, Limited, Tokyo, and former Managing Director of the Sumitomo Electric Wire & Cable Works, Limited, Osaka, passed away on March 6th, 1938, at the age of 65.

After graduating in 1899 from the Electrical Department, School of Engineering, Tokyo Imperial University, Mr. Akiyama entered the Ministry of Communications. In 1911 he resigned from the Ministry, where he had held various high posts, and began a new career as Assistant Manager with the Sumitomo Electric Wire & Cable Works, Limited, one of the numerous companies comprised in the huge industrial and financial "Sumitomo Interests." When he retired at the age of 63, he was not only the Managing Director of the Works, but one of the Directors of Sumitomo Goshi Kaisha (now Sumitomo Honsha), the holding company. During his later years he served as executive officer in as many as eighteen important companies and associations in Japan. In 1935 he was President of the Institute of Telephone and Telegraph Engineers of Japan (now Institute of Electrical Communication Engineers of Japan), and in 1936 he was elected President of the Institute of Electrical Engineers of Japan.

The story of his climb up the ladder of success is like that of many great personalities one often reads about. Born in a little village in the mountains of Northern Japan, in a home of very meagre means, but endowed with a brilliant mind, a strong will, a steady and upright character, and a nature imbued with kindness and gentleness, Mr. Akiyama laboured in silence and deservedly earned every upward step.

A man true to the traditions of his people, he never forgot his duties to the family of which he was a member, and was ever conscious of his obligations to society. He was most generous with his possessions and was always ready to help along a good cause. His last benefaction was to his native town, Yonezawa, to which he donated his retirement allowance, received from Sumitomo Goshi Kaisha in 1936, to be used as an endowment for education.

All those who had the privilege of knowing Mr. Akiyama will cherish the memory of a great man who was unostentatious, serene and thoroughly good.

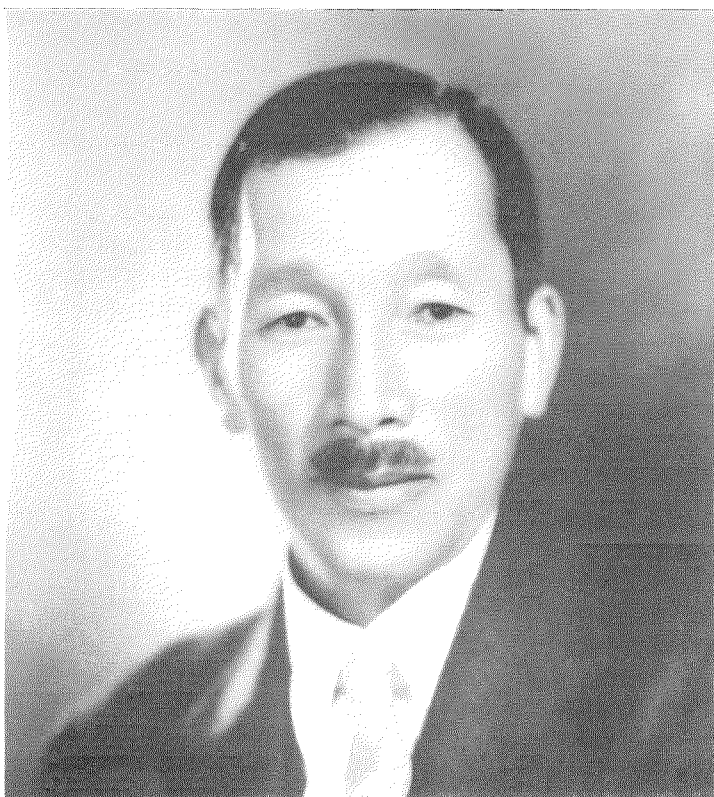

FUMIO SHIDA (1886-1938)

FUMIO SHIDA, Managing Director of the Nippon Electric Company, Limited, and Director of the Sumitomo Electric Wire and Cable Works, Limited, died on April 27th at the age of 52. He left behind him a splendid record, not only as a business executive of the largest establishment of its kind in the Orient, but as an engineer—a consummation undoubtedly due to his well-known brilliant mind combined with keen business judgment and a broad vision.

He was the son of Dr. Rinzaburo Shida, a distinguished engineer and pioneer in the field of communication engineering in Japan. Graduating in 1913 from the School of Science and Engineering of Kyoto Imperial University, Mr. Shida entered the Ministry of Communications. After serving the Government for seven years he joined the Sumitomo Electric Wire and Cable Works where his rise was rapid. In five years he became Chief Engineer and, in another seven years, one of the Directors of the Works and Managing Director of the Nippon Electric Company, Limited.

In addition to his many other interests, his contributions to the science of communication engineering were great and will have a far reaching effect, not only in the immediate present but in the years to come. In January, 1938, he was elected Vice-President of the Institute of Electrical Communication Engineers of Japan, and was presented by the Institute with the Distinguished Service Medal, which is the highest token of honour in Japan in the field of electrical communication engineering. He left behind him a son, Rintaro Shida, who is actively pursuing studies in the communications field in an endeavour to successfully follow in the footsteps of his father and grandfather.

Mr. Shida was a most lovable and amiable man, clean to the core. His interests in private life were wide and account for the great number of his friends in many lands. He will ever be held in grateful memory by all who knew him.

A Simple Dial-operated Teleprinter Switchboard

By LESLIE B. HAIGH, M.A., A.M.I.E.E.,

Development Laboratories, Bell Telephone Manufacturing Company, Antwerp, Belgium

WITH the increasing use of the teleprinter, the problem of "switching" teleprinter subscriber lines becomes more and more complex. International switched connections between several countries on the European continent have for some time been an established fact; the distances bridged by such connections are often very considerable and the co-ordination of line sections, operating on a variety of systems and perhaps linked

together at a number of switching points, may be involved.

The general trend in the design of switching plant for public teleprinter service must inevitably be towards improved transmission quality, because of the distances traversed and the increasing number of line sections; also greater equipment flexibility, by reason of the wide variety of line and switching

conditions encountered; and more uniform operating and signalling methods, in order that equipment of different types may readily interwork. Some new examples of switching plant designed with these ends in view have recently been described.¹

The utility of such equipment is, obviously, not restricted to switching systems conceived on international lines; it fulfils economically the less ambitious requirements of a number of institutions—railway, police, airway, press agency, etc.—where an intercommunication network separate from the public service is required. On the other hand, a demand exists for teleprinter switching facilities of a much simpler character, providing internal or local service only; first cost and maintenance charges of an exchange in such cases are important considerations.

To meet this demand, the European Laboratories of the International System recently have developed a dial-operated switchboard with strictly limited facilities; it is simple both in design and operation, and is known as the type No. 7111 Automatic Teleprinter Switchboard. The No. 7111-A switchboard for 10 lines, and the No. 7111-B for 19 lines, are illustrated in Figs. 1 and 2, respectively. In both cases, the apparatus is mounted on a self-supporting framework and is normally totally enclosed.

Airport Switchboard Installation

A recently rebuilt airport is served by Creed Model 7-CTK teleprinters, inter-connected through a No. 7111-B switchboard. This equipment carries all the internal teleprinter traffic of the airport, including the broadcasting of orders from the control station, under the dome of the central tower, to the direction-finding posts, the

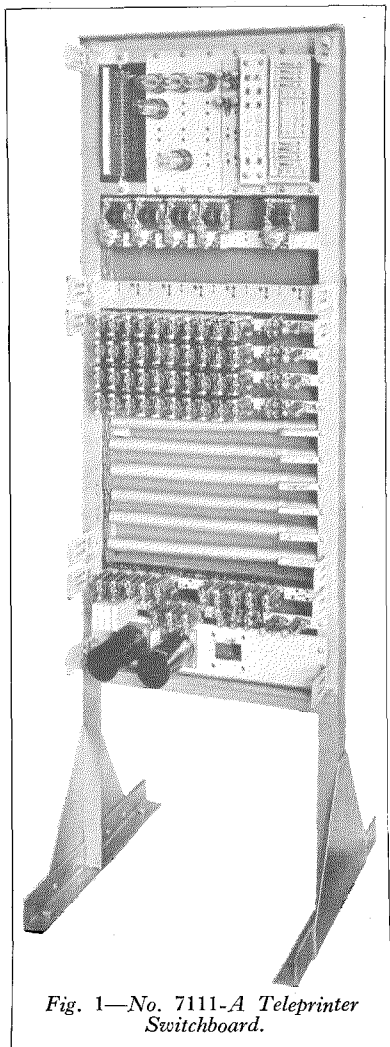

Fig. 1—No. 7111-A Teleprinter Switchboard.

¹ "Some Recent Developments in Teleprinter Switching Systems," by P. J. Clemens, *Electrical Communication*, January, 1938.

meteorological station and other departments, simultaneously.

Some Novel Features

The design of the No. 7111 switchboard includes several deviations from established teleprinter switching practice, introduced with a view to attaining the utmost simplicity in operation and ease of maintenance.

The most outstanding, perhaps, is the use of 3-wire lines. The object of this departure from the usual 2-wire line system is the complete separation of the transmission and connection-holding circuits. The transmission circuit in a switched connection between two teleprinters contains no telegraph repeater and consists of a closed metallic loop fed with current from a battery at the switchboard. This loop includes neither motor-controlling relays at the teleprinter stations nor clearing relays at the switchboard to interfere with the transmission quality; the transmission circuit, in fact, closely resembles that of a "single-current" point-to-point connection between two teleprinters. Consequently, it is possible to obtain satisfactory operating margins over short lines with a transmission voltage as low as 48 volts. Since the switching circuits also require this voltage, the need for separate switching and high-voltage transmission batteries, and separate supply-circuits at the switchboard, is entirely avoided.

Reference to the routing diagram, Fig. 3, will disclose another departure: each station line has its own individual selector; an 11-point single-motion step-by-step switch in the smaller size of switchboard, and a similar 22-point switch in the larger. With the long holding time and the high calling rate for which it is necessary

to provide, if teleprinters are to compete successfully with alternative means of communication, this arrangement is more economical than the more familiar combination of preselectors and selectors, or line finders and selectors, when the number of lines is small. The advantage is less marked when there are more than ten lines, but inasmuch as a switchboard is not usually supplied at the outset with equipment for the maximum possible number of lines, the same arrangement was chosen for both sizes of switch-

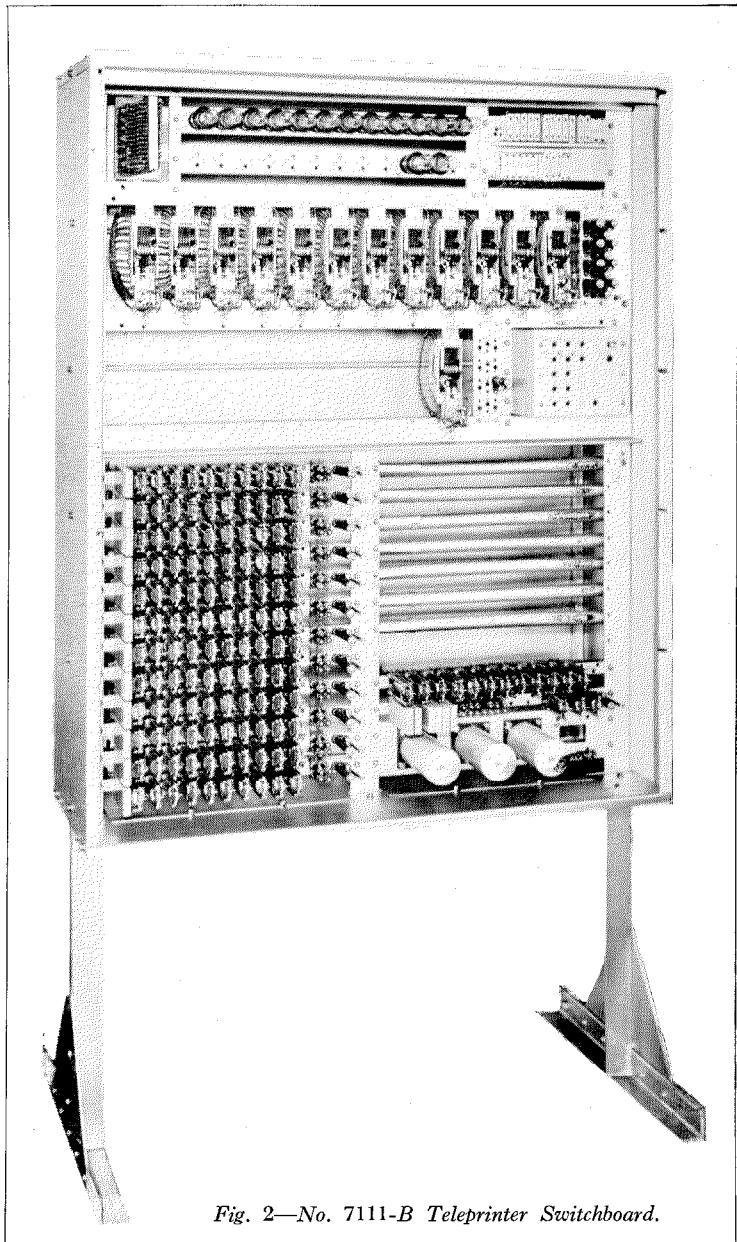

Fig. 2—No. 7111-B Teleprinter Switchboard.

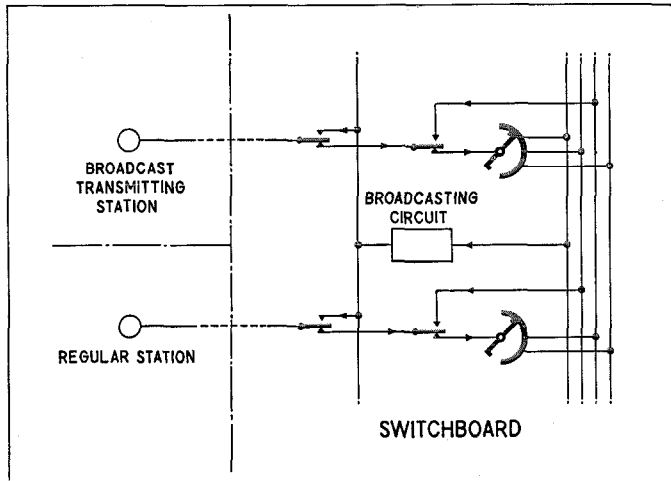

Fig. 3—Routing Diagram.

board and their circuits are, therefore, almost identical.

Station to Station Calls

The establishment of a connection is simple and rapid and is performed with the aid of a "control box" (Fig. 4), placed beside the teleprinter. To call another station, the starting key is depressed and the teleprinter motor instantly begins to revolve: a single digit is dialled (with the larger switchboards nine lines have single digit numbers and the remainder have two digit numbers); if the motor continues to run, the connection is established; if it stops, either an unobtainable number has been dialled or the line is already engaged.

The starting key is not strictly necessary: a selector is permanently associated with each line and turning of the dial is sufficient to initiate a call. The supplementary feature is included solely as a safeguard against the inadvertent disturbance of the dial.

Release takes place instantaneously when the releasing key at either station is depressed; if this operation is neglected and no

transmission occurs during a minute or so, release is automatic.

Broadcasting

Broadcasting facilities of the "non-selective" type are provided and the operations involved are not complicated. Access to the broadcasting circuit is restricted to two of the stations, which reach it by dialling the numbers of their own lines—the choice of another number would reduce the effective capacity of the switchboard. A station so connected can broadcast immediately to all the other stations wired for this service, but the latter, while broadcasting is in progress, cannot themselves transmit; thus mutilation of messages is prevented.

The receiving stations can acknowledge receipt of a message, when requested to do so, by the depression of their releasing keys.

The control box at a broadcasting station is somewhat different from the normal design, and carries an additional key and a lamp. With their aid, the broadcaster is able to verify collectively or, if necessary, individually, that the acknowledgment signal has been duly transmitted from each receiving station. Operation of the key enables him to dial on to a checking switch; his lamp burns when he dials his own number, provided all have acknowledged; a similar check of a particular line is obtained by dialling the number of that line.

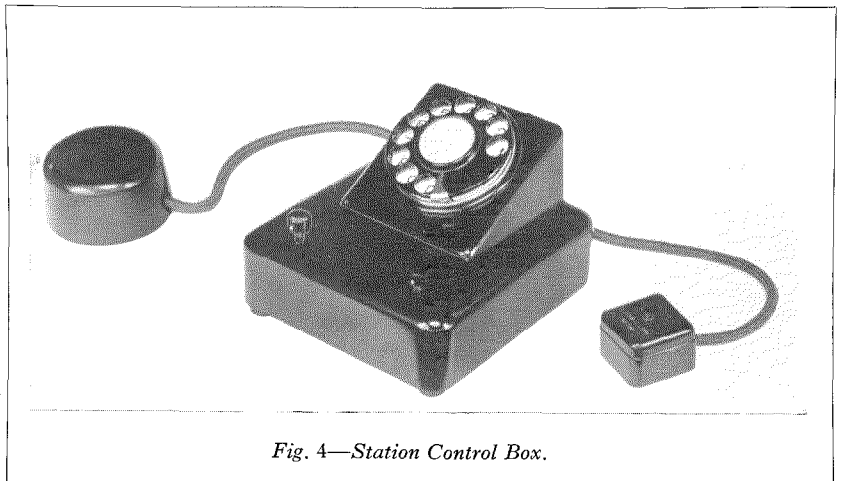

Fig. 4—Station Control Box.

Application of Single Channel Carrier to Existing Loaded Cables in Switzerland*

By H. JACOT, Dip. Ing. E.P.F.,

Research Section, Swiss Telephone Administration

WHEN most of the long distance routes were open wire lines, and prior to the extensive introduction of underground loaded cables, engineers were faced, due to traffic growth, with the problem of increasing the number of circuits without too great expense. Since open wire lines are suitable for passing a very wide frequency band, it was found possible by a shift in frequency to provide a number of separate speech channels for transmission over the same line. Thus three speech channels could be transmitted over the open wire lines simultaneously with the normal speech channel.

Transposition of a channel to another part of the frequency band is accomplished by the modulation of a carrier frequency current, the channel being subsequently returned by demodulation to its normal place in the frequency band. Since 1918, carrier telephony on open wire lines has been used commercially on a large scale. The Swiss Administration, in 1920, provided carrier circuits between Bâle and Zürich and between Bâle and Berne, and they remained in service until 1924.

The laying of underground cables over the main routes retarded the extension of these carrier circuits, which were relegated to a less important position except, of course, where major open wire routes were maintained. The relatively high cost of carrier terminal equipment made loaded cable systems more economical than open wire carrier systems; furthermore, the former were more reliable in operation.

It is well known that the development of the underground cable network in Switzerland was hastened by the electrification of the railways as well as by the great increase in traffic following the introduction of automatic telephony. Thus all the main open wire routes disappeared gradually. As international traffic increased and new connections were set up, the 4-wire extra light circuits in the various cables were soon all in service and it became desirable to find a method of obtaining more 4-wire circuits, if possible, without laying new cables. Existing telephone circuits used the 300 p : s to 2 400 p : s frequency band. As extra-light phantom circuits, loaded H-20, have a cut-off frequency of 7 000 p : s, it therefore seemed possible to superimpose a carrier channel above the speech channel by the use of the lower side band of a carrier frequency of 6 000 p : s. The desired characteristics of single channel carrier systems have been defined by the C.C.I.F.; in general they are similar to those of 4-wire voice frequency circuits.

PRELIMINARY TESTS

The extra-light phantom circuits, on which carrier operation was proposed, have the following characteristics :

Loading Coil Inductance ..	20 mH
Loading Coil Spacing ..	1 830 m.
Conductor Diameter ..	0.9 mm.
Capacity	0.057 μ F per km.
Cut-off Frequency ..	7 000 p : s.

These circuits were originally designed only for voice frequency working, and their possible use at carrier frequencies involved such risks as regards noise and crosstalk that it was necessary to determine experimentally whether or not

* Published in *Technische Mitteilungen* No. 2, 1938, pp. 41-52.

superimposed carrier circuits of C.C.I. quality could be obtained. Hence a series of tests was undertaken in the spring of 1937 by Standard Telephones and Cables, Ltd., London, and the Swiss Administration Research Section on a 360 km. circuit, from Berne, made up of six repeater sections containing cables manufactured at widely differing times.

The tests were quite conclusive, and showed that single channel circuits of good quality could be obtained in this way.

With ordinary 4-wire repeaters, either of the old type using 1 amp. or $\frac{1}{4}$ amp. valves, or of the new type using $\frac{1}{4}$ amp. valves only, it was found possible to equalise the circuit satisfactorily over a frequency range of 300 p:s to 5700 p:s to within ± 0.07 neper (± 0.6 db.). In all cases the frequency of 5700 p:s was still quite well transmitted—an important result since 5700 p:s corresponds to 300 p:s in the voice frequency range.

Crosstalk and noise on carrier systems may be caused by:

- (1) Effect on the carrier channel of harmonics in the voice frequency channel;
- (2) Partial rectification by the voice frequency channel of the carrier channel side bands;
- (3) Modulation by the voice frequency channels of the carrier side band during simultaneous passage of both channels through the repeaters (intermodulation).

A copper-oxide rectifier, shunted by a resistance, the value of which was determined experimentally, was connected to the output of each repeater in order to reduce the even

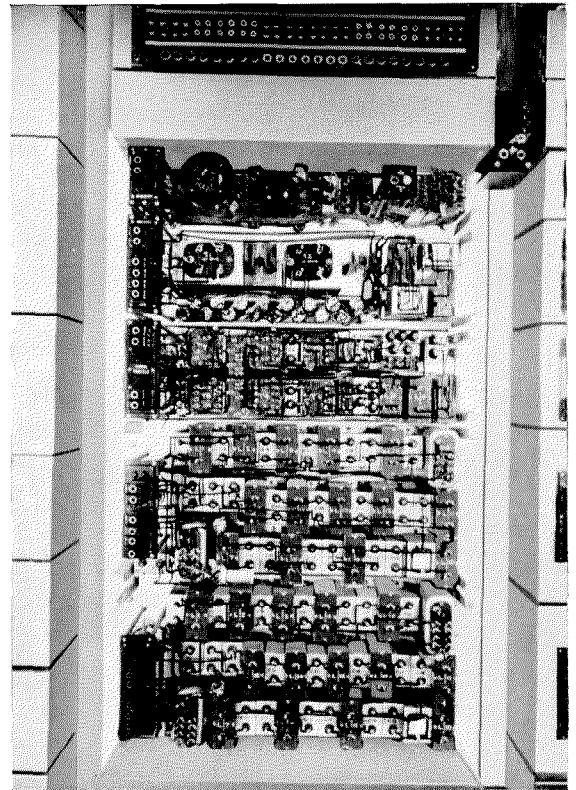

Fig. 2—Equipment for Single Channel Carrier Telephony.

harmonics produced by the valves of the intermediate repeaters. These rectifiers eliminate the even harmonics produced by the non-linearity of the valve characteristics and also reduce the crosstalk between the carrier and voice frequency channels.

The most suitable levels for these two channels were determined by measurements of crosstalk from the voice frequency to the carrier channel and vice versa; more or less identical values of crosstalk were obtained in all cases. The level of the voice frequency channel at the output of each repeater was fixed at zero and that of the carrier channel at -0.58 neper (5 db.). When the circuit was set up in this way the measured crosstalk in all cases was better than 7.1 nepers (62 db.) for an output volume of 0.58 neper (5 db.) below reference volume. With output volumes of 1.16 neper (10 db.) and 1.73 neper (15 db.) below reference volume, the crosstalk was better than 7.7 nepers (67 db.) and 8.5 nepers (74 db.) respectively. It is generally admitted, as a result of numerous tests, that the

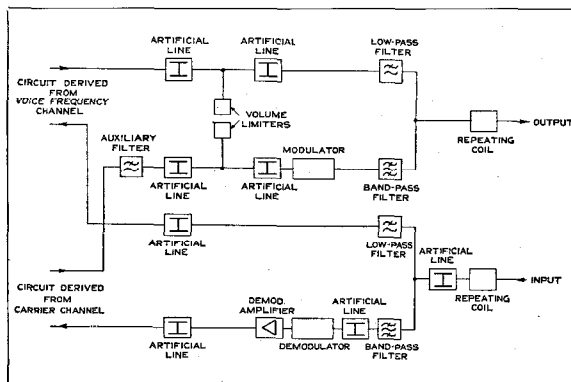

Fig. 1—Block Schematic of Single Channel Carrier System.

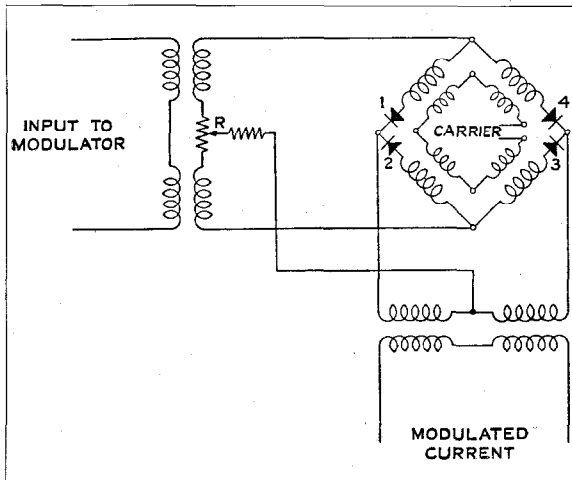

Fig. 3—Modulator Schematic.

average value of the output volume from subscribers is 1.73 neper (15 db.) below reference volume. It should be added that, in the above measurements, the levels of -0.58 neper and -1.16 nepers were applied directly at the 2-wire side of the 4-wire terminating set.

Measurements of cable crosstalk made over the whole frequency band up to 6 000 p : s between phantom circuits of a group in the Berne-Olten cable showed that it is always possible to choose and balance circuits so that the crosstalk is never worse than 7.5 nepers (65 db.) on the completed circuit.

The equivalents of the voice frequency and carrier channels when the input energy is increased from 1 to 4 mW do not vary more than 0.05 neper (0.43 db.) over the whole frequency range.

As a result of these tests the Swiss Telephone Administration decided to adopt the single channel carrier system in order to increase the number of 4-wire circuits, particularly between Bâle and Zürich where the need was greatest at the moment. The equipment for both terminal stations was supplied by Standard Telephones and Cables,

Ltd., London, and put into service just before Christmas, 1937.

DESCRIPTION OF CIRCUIT

Fig. 1 illustrates the general principle of the single channel carrier system.

Voice Frequency Channel

The voice frequency channel, which is not modulated, is not shifted in the frequency scale and is transmitted unchanged on to the line along with the carrier channel.

The voice frequency channel passes through an artificial line adjusted so that the level at the volume limiter is -0.46 neper (4 db.). The function of the voltage limiter is to ensure that no excessively intense peak voltages shall be permitted to pass with risk of interference with the other channel by momentarily overloading the line repeater. A second artificial line regulates the levels sent to the line. A low pass filter cuts off all frequencies above 3 000 p : s. The line repeating coil is connected to the line repeater, which is not shown in the figure.

At the receiving end there is a repeating coil followed by an artificial line regulating the input level to the two channels. A low pass filter separates the bands above and below 3 000 p : s. A second artificial line regulates the level at the input of the line repeater or of the 4-wire terminating set.

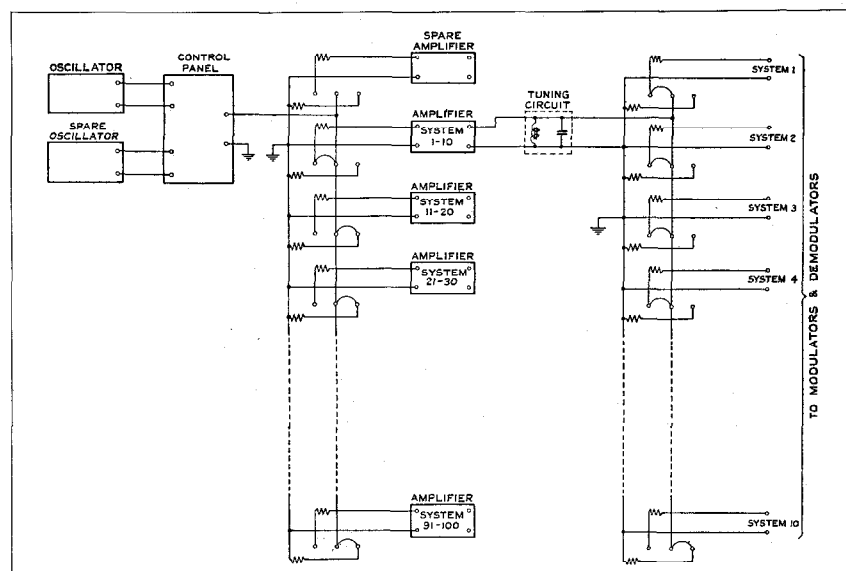

Fig. 4—Block Schematic of Carrier Current Supply.

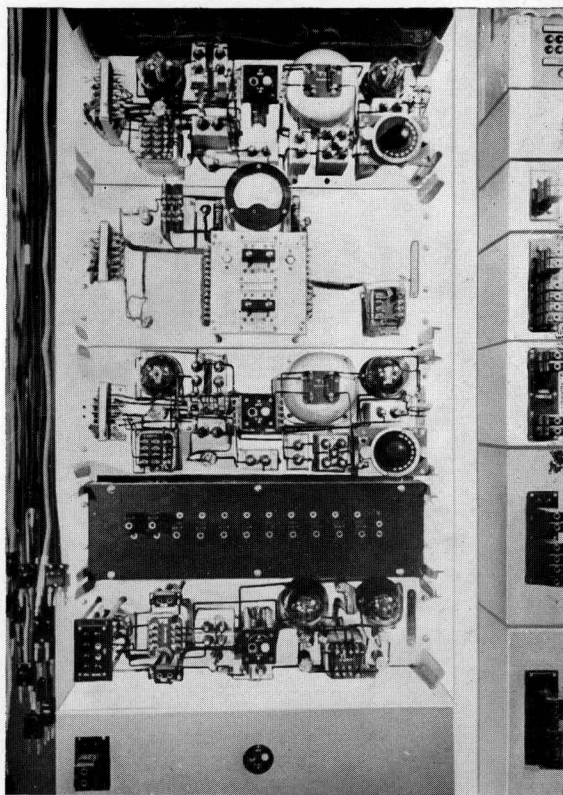

Fig. 5—Carrier Supply.

Carrier Channel

At the output there is first an auxiliary filter with a cut-off frequency of 6 000 p : s. An artificial line regulates the volume limiter level, which is -0.46 neper (4 db.) referred to zero level as before. A second artificial line regulates the level of the carrier channel on the line to -0.58 neper (5 db.). Next, the modulator, which is of the dry rectifier type with a carrier frequency of 6 000 p : s, transposes the normal voice currents up to the 3 000-6 000 p : s band, and a band pass filter allows this band to pass. The same repeating coil as for the voice frequency channel transmits the modulated current to the line.

At the receiving end, a repeating coil and an artificial line are used, the same as for the voice frequency channel. A band pass filter allows the 3 000-6 000 p : s band to pass.

The demodulator, which is substantially identical to the modulator, transposes the modulated current into the normal frequency band. The artificial line in front of the demodu-

lator regulates the level to provide for operation under the best conditions. The amplifier following the demodulator and an artificial line serve to bring the level of the demodulated current back to the required value either for the line repeater or for the terminating set.

The modulator is shown schematically in Fig. 3. It is of the copper-oxide rectifier type. Depending on the phase of the carrier voltage, the elements 1 and 3 or 2 and 4 are in a conducting condition. The potentiometer R allows the circuit to be balanced so as to suppress the carrier at the output of the modulator; in every case the level is below 4.5 nepers (39 db.). We thus have at the output of the modulator two side bands, $F+f$ and $F-f$, as products of modulation (F = carrier frequency; f = modulating frequency) and other products $3F \pm f$, $5F \pm f$, etc. Only the lower side band $F-f$ is transmitted, all other products of modulation being suppressed by the filters.

Carrier Current Supply (Fig. 4)

At each terminal station there are two oscillators (of which one is a spare) supplying carrier current for the modulators and demodulators. The frequency of the oscillators at the two stations, Bâle and Zürich, are adjusted to 6 000 p : s ± 1 p : s, and they remain very constant. The frequency can be checked by means of a control circuit, Zürich being taken as the control station, and each oscillator can be adjusted for frequency by a variable condenser. A special distributing panel distributes the carrier current from the oscillator to a special amplifier. One amplifier can supply ten systems, and an oscillator can feed 10 amplifiers plus 1 spare. Thus one oscillator suffices for 100 channels. A circuit tuned to 6 000 p : s is connected to each amplifier and prevents any frequencies other than the carrier frequency passing to the modulators and demodulators, thereby reducing the crosstalk between the various channels. Resistances protecting the oscillator prevent failure of carrier current supply to all channels due to a short circuit. Fig. 4 shows the schematic of the carrier current supply.

The equipment is completed by testing apparatus for measuring the filament current to oscillators and amplifiers. The oscillators and

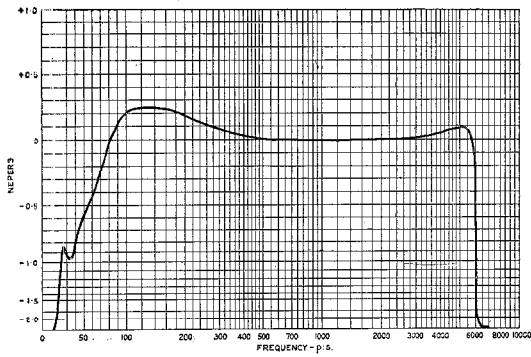

Fig. 6—Bâle-Zürich, H-20 Phantom Circuit No. 1 : Loss-Frequency Curve Measured at Zürich.

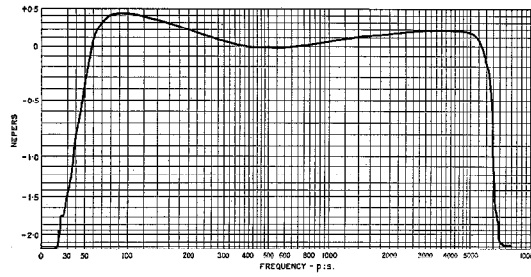

Fig. 7—Zürich-Bâle, H-20 Phantom Circuit No. 1 : Loss-Frequency Curve Measured at Bâle.

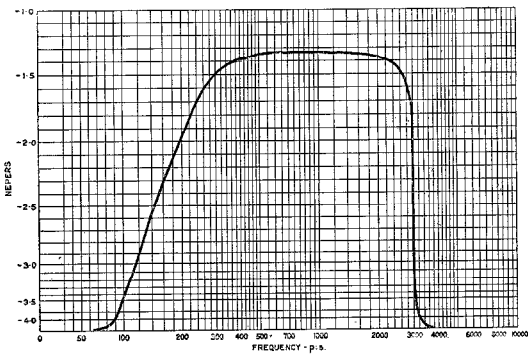

Fig. 8—Bâle-Zürich, Voice-Frequency Channel No. 1 : Loss-Frequency Curve Measured at Zürich Terminating Set.

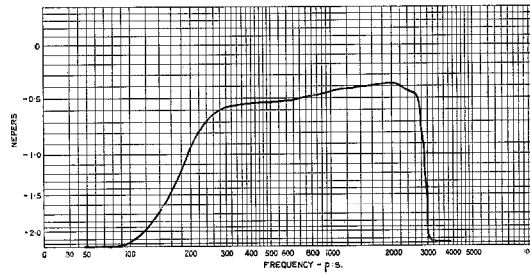

Fig. 9—Zürich-Bâle, Voice-Frequency Channel No. 1 : Loss-Frequency Curve Measured at Bâle (Including Terminating Set at Zürich).

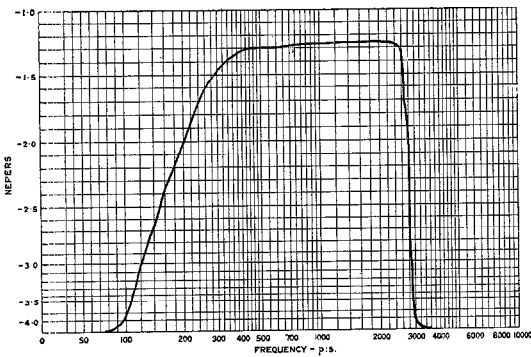

Fig. 10—Bâle-Zürich, Carrier Channel No. 1 : Loss-Frequency Curve Measured at Zürich Terminating Set.

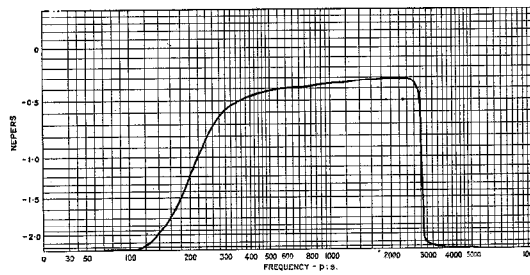

Fig. 11—Zürich-Bâle, Carrier Channel No. 1 : Loss-Frequency Curve Measured at Bâle (Including Terminating Set at Zürich).

amplifiers are situated on a double bay suitable for an ultimate equipment for 100 channels.

The channel bays accommodate two complete systems on each half bay, as well as the fuses, ballast lamps, and filament and plate ammeters.

RESULTS ON BALE-ZÜRICH CIRCUITS

The H-20 phantom circuits between Bâle and Zürich (contained in a cable laid in 1930), on which the carrier systems have been installed, are 105 km. long; intermediate 4-wire repeaters are not as yet installed. The circuits to be extended to Zürich come into Bâle normally through ordinary 4-wire repeaters (see Fig. 12). No change was necessary in the gains of the repeaters amplifying towards Bâle. The gains of the other repeaters (away from Bâle), however, had to be changed because they were required to compensate for the losses in the carrier equipment instead of for those in a repeater section of cable. By means of low frequency correctors and the equalisers of the ordinary 4-wire repeaters at Bâle and Zürich, the line was equalised for the whole 300-5 700 p:s frequency band. The results were satisfactory, especially in view of the unusual length between repeaters (105 km.) of the circuit to be equalised,

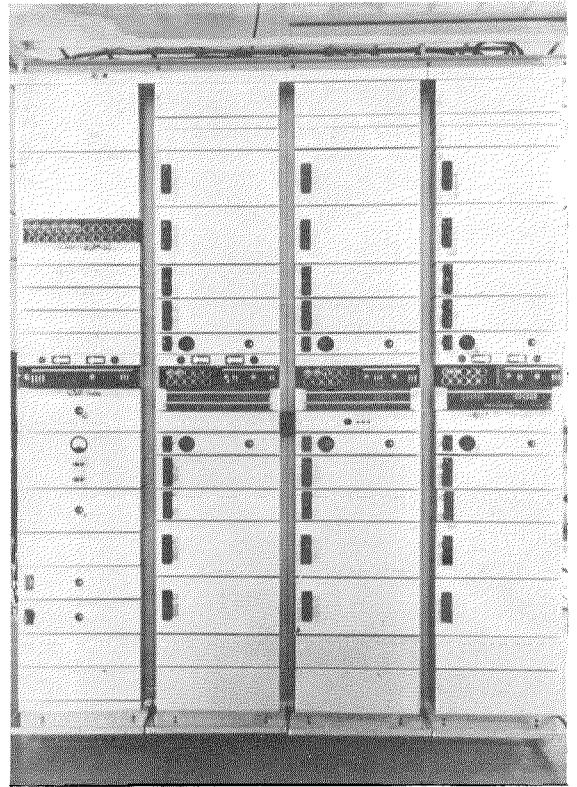

Fig. 13—Bay Containing Equipment for Six Carrier Channels.

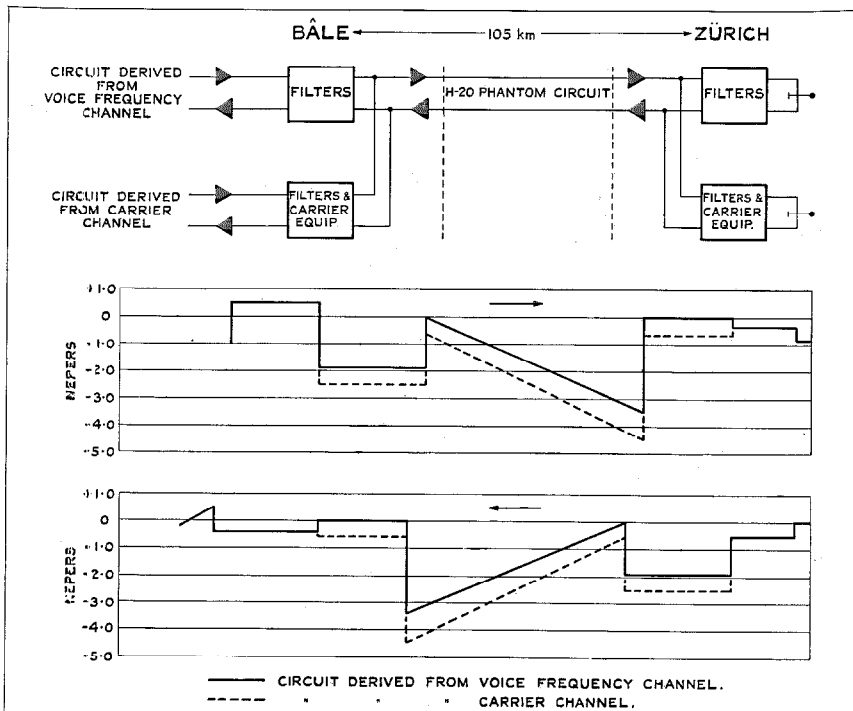

Fig. 12—Level Diagram.

of the low value of the cut-off frequency of the loaded circuit (7 000 p:s against 8 000 p:s for normal single channel circuits) and of the fact that existing voice frequency repeaters were used. Considerable improvement would of course be obtained if intermediate 4-wire repeaters were installed. Figs. 6 and 7 show the equivalents as a function of frequency in both directions for Bâle - Zürich circuit No. 1. Figs. 8 and 9 show the equivalent of the voice frequency channel on this line. Fig. 8 was obtained by

transmitting direct at the input of the carrier system at Bâle and measuring the equivalent at the terminating set at Zürich. The level is too low by 0.5 neper, due to the fact that the 4-wire repeater was not connected into the carrier channel. Fig. 9 gives the equivalent when transmitting from the 2-wire side of the Zürich terminating set and measuring the equivalent on the office side of the Bâle carrier system. Inclusion of the 4-wire repeater in the circuit would bring the level back to its normal value of +0.5 neper.

The curves of Figs. 10 and 11 are the most interesting since they give the equivalents of the carrier channel in the two directions. The equivalent at the Zürich terminating set is also 0.5 neper too low for the same reason as in the case of the voice frequency channel. The equivalent at Bâle was brought to the same level as the voice frequency channel to allow the repeater gain to be adjusted to the same value for all the carrier circuits. It should be added that on the Bâle-Zürich circuit the voice frequency and carrier channels are transmitted with a level difference of 0.58 neper (5 db.). Fig. 12 shows the level diagram.

Complete crosstalk tests could not be made because the circuits had to be put into service for the holidays. But it can be said that the crosstalk is no worse than that measured during the Berne tests. This applies to crosstalk from the voice frequency to the carrier channel and vice versa. In general it can be said that the crosstalk was less than the noise due to crosstalk from other parts of the circuit or from power plant at the repeater stations.

The circuits extended by carrier from Bâle to Zürich (there were two Paris-Zürich, and two London-Zürich circuits) completely fulfil the conditions required for international 4-wire

circuits, as regards quality of transmission, stability, crosstalk and noise.

CONCLUSION

The preliminary tests made at the beginning of 1937 and the practical application of single channel carrier on extra-light phantom circuits, loaded H-20, showed that it was possible, by taking certain precautions, readily and economically to increase the number of 4-wire circuits in the cables of the Swiss long distance network, even though the circuits were not designed for carrier application. The circuits thus set up are as satisfactory in quality as the ordinary circuits. The equipment takes up little space and is very reliable.

This application of carrier to the Swiss cable network is of interest at a time when carrier on cable is coming into use on a large scale. Examples are the 12-channel carrier systems first used between Bristol and Plymouth and now employed at many other places throughout England; also the London-Birmingham and Berlin-Nuremberg-Munich coaxial cables. The coaxial cable allows a very large number of conversations on a specially designed structure; 12-channel carrier systems provide 12 channels per pair on multi-conductor, non-loaded cables.

Thanks to simplification and technical improvements which have been made in carrier systems during the last few years (feed-back repeaters, crystal filters, modulators and demodulators with dry rectifiers) a new era in telephone communication is opened.

The present tendency in long telephone circuits is not only to eliminate loading coils but also to reduce radically the number of conductors in a cable. The 4-wire circuits thus derived permit working with a lower equivalent and give better quality than normal 2-wire circuits, and are equal to the 4-wire voice frequency circuits.

Irregularities in Telephone and Television Coaxial Cables*

By LEON BRILLOUIN,

Professor of the Collège de France

Irregularities in telephone cables produce disturbances in the propagation of signals, resulting in reflected waves and distortion of the signal. In the present article both effects are studied on a very general basis, and the theory developed includes as special cases the published calculations† of Didlaukis and Kaden and of Mertz and Pflieger. Practical applications to television cables are discussed at length, including the highly diverse roles played by local irregularities and by variations between reel lengths. The effect of grouping of reel lengths also is considered.

Table I gives the most important formulæ and summarises the principal results for the benefit of the reader who may not wish to become involved in detailed derivations. It will enable him to pass directly from the more generalised parts of the article (sections 1 to 5) to the practical applications (sections 13 to 18). The intervening sections (6 to 12) are included to facilitate co-ordinating the present studies with those of Mertz and Pflieger as well as of Didlaukis and Kaden, both of which are based on very different methods.

(1) INTRODUCTION

DUE to the utilization of increasingly higher frequencies in the communication art, precise evaluation of the effects of cable irregularities on the propagation of signals is assuming great importance. Such irregularities may result from slight variations in the cable structure and may be introduced either during manufacture or installation. In any case the two-fold problem arises: (1) determination of the nature and extent of the irregularities; and (2) evaluation of the resulting effects.

Initially, a slight irregularity in the structure of the cable will make itself felt by a small variation in its local characteristic impedance and cause *reflection*, as indicated diagrammatically in Fig. 1. There thus results a series of attenuated waves which are reflected and which return to the origin O of the cable, manifesting themselves by a complex *echo* and by a *variation of the input impedance*. A second effect, illustrated diagrammatically in Fig. 2, consists in a double reflection at two points of irregularity. Here a wave is produced and superimposed at the output side on the direct wave, giving rise to a prolongation of the signal, hereafter called the *signal tail*.

Because of its very general application—not

only in the realm of electricity, such as in telephony and telegraphy, but also in acoustics, such as in the phenomenon of echo effects in large halls,—it is important to note a characteristic of these signal tails: the phenomenon is identically the same in form at the beginning and end of a signal.

(2) THE SIGNAL AT ITS BEGINNING AND END

Consider a telegraph signal consisting of a continuous dash, t_0 to t_1 (Fig. 3). The signal arrives with a delay T (propagation time) and is distorted. The beginning of the signal is no longer instantaneous but the current takes a time θ to reach its maximum value. Similarly, the end of the signal is not instantaneous but decays during an interval θ . The phenomenon at the beginning and end of the signal is identical.

Actually, when only linear systems are involved (coils without hysteresis, amplifiers without distortion), the mechanism of transmission makes possible the superposition of signals without mutual interaction. Assuming, then, a continuous and fairly long dash beginning at time t_0 , it may be considered as consisting of two distinct signals (Fig. 4): a dash from t_0 to t_1 , followed immediately by another dash from t_1 to infinity. Consider the phenomena at the receiving end at the instant $t_1 + T$: the signal interrupted at t_1 decays; the signal commencing at t_1 increases in amplitude; and the superposing of both signals produces a continuous signal, as indicated in

* Translated, with slight modifications, from article in *Annales des Postes Télégraphes et Téléphones*, April, 1938, entitled "Le Rôle Des Irrégularités Sur Les Câbles (Câbles téléphoniques, câbles coaxiaux et câbles pour télévision)."

† See references Nos. 3 and 4.

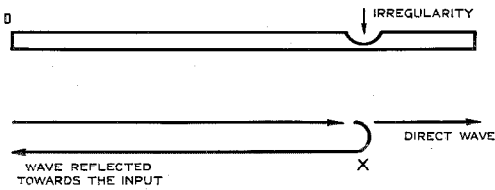

Fig. 1.

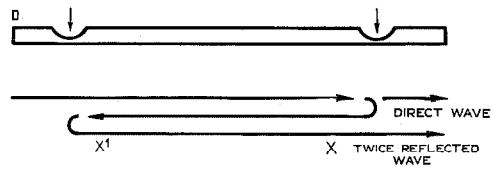

Fig. 2.

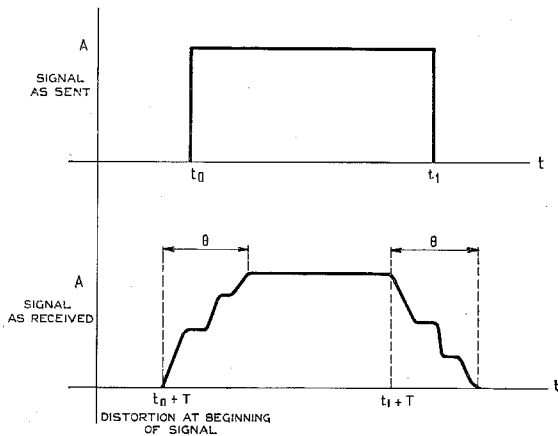

Fig. 3.

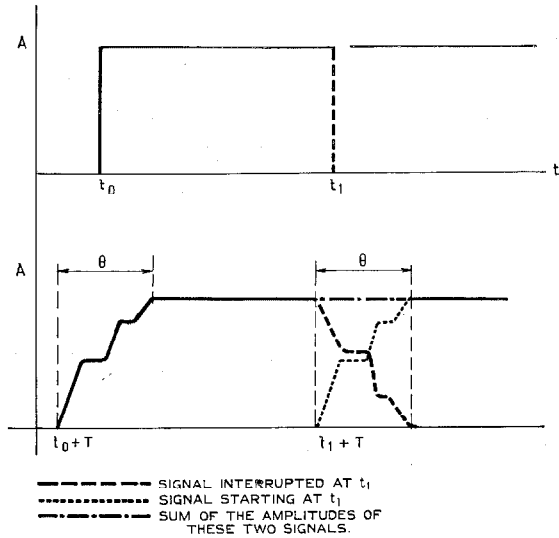

Fig. 4.

Fig. 4. The curves of growth and decay must therefore be exactly complementary.

Passing from the simple example of a telegraph signal to a modulated signal, it is necessary to note the phase effect. The same essential rule always applies; it may be defined as follows:

Take a signal I_{10} of frequency ω transmitted with an amplitude of unity and lasting during the period $-\infty$ up to $t = 0$. If this signal be interrupted abruptly at $t = 0$, it is transformed on reception into a signal displaced by T (propagation time) and distorted. The received signal may be written:

$$I_{1r} = A_1(t + T) e^{j\omega(t+T)} \text{ (interrupted signal).} \quad (1)$$

The amplitude A_1 (Fig. 3) is a complex function of time and thus embraces the real amplitude and the phase relationship.

For $t = 0$, the amplitude $A_1(T)$ is real if T be suitably selected.

For positive values of t , equation (1) gives the value of the signal tail. If t be greater than θ , the amplitude A_1 becomes negligible. The notations are therefore comparable with those of Fig. 3.

Assume a signal I_{20} beginning at $t = 0$ with the same phase and frequency, such that superposition of $I_{10} + I_{20}$ supplies an uninterrupted sinusoidal current:

$$I_{10} + I_{20} = e^{j\omega t}. \quad (2)$$

This signal, I_{20} , will be received in the form of a current beginning at the instant T :

$$I_{2r} = A_2(t + T) e^{j\omega(t + T)}. \quad (3)$$

The complex amplitude A_2 embraces all the growth phenomena at the beginning of the signal. Superposition gives a continuous signal maintaining the amplitude relationship of:

$$A_1(t + T) + A_2(t + T) = A_1(T). \quad (4)$$

Equation (4) is valid for the complex magnitudes representing amplitudes, and includes the identity of the tail effects at the beginning

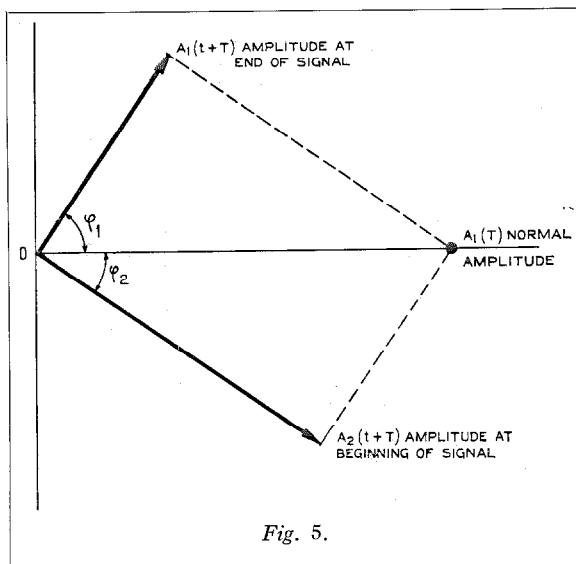

and end of a signal, as indicated diagrammatically by the rotating vectors in Fig. 5. Considering the intensities of the signals, the equation becomes more involved; separating the real amplitudes a and the phases φ :

$$A_1 = a_1 e^{j\varphi_1} \text{ and } A_2 = a_2 e^{j\varphi_2}$$

gives:

$$a_1 e^{j\varphi_1} + a_2 e^{j\varphi_2} = a_1(T) \quad (\text{real, operating condition}) \quad (4a)$$

$$a_1^2 + a_2^2 + 2 a_1 a_2 \cos(\varphi_1 - \varphi_2) = a_1(T)^2; \quad (5)$$

the phase relationships complicate the problem.

Obviously it is sufficient to study one of the two phenomena to know the other¹; in general, the effect at the end of the signal is chosen since it lends itself to more direct physical representation than that at the beginning.

Suppose that the tail phenomenon is due to a large number of partial components distributed haphazardly with regard to phase relationships. Taking an average a law may be derived, not exactly accurate in detail, nevertheless, giving the average form of the growth or decay of the intensity of the wave. The phase term

$\cos(\varphi_1 - \varphi_2)$ disappears from equation (5) and it follows that:

$$a_1^2 + a_2^2 = a_1(T)^2; \quad (6)$$

the mean increase and decrease of the intensities are symmetrical. This equation illustrates approximately, on the hypothesis of haphazard phase distribution, the more rigorous amplitude relationships inherent in equation (4).

The similarity of the increasing and decreasing curves is very clearly shown if the phenomena be sufficiently slow to be followed with an oscillograph. Thus, in acoustics, the well-known multiple reflections from surfaces in a large hall cause echoes resulting in reverberation. Fig. 6 is a reproduction of a recording of these phenomena²; it shows strikingly the similarity of the growth and the decay of the sound. In connection with cables containing irregularities, phenomena of exactly the same character are to be expected.

(3) IRREGULARITIES IN A CABLE: THEIR FORM AND CORRELATION FUNCTION

The part played by the irregularities of a cable on the propagation of signals has recently been the object of considerable study^{3, 4}. The methods adopted by the authors cited are very different. Didlaukis and Kaden assume chance distribution of defects throughout the cable; the defects cannot be regarded as infinitely short, but must be presumed to have a finite length. Their calculations cover two types of defects of different kinds, general conclusions being drawn therefrom. Mertz and Pflieger proceed by assuming the cable to be divided into small sections of equal length, each with its own individual impedance. These two methods lead to rather different calculations but confirm the general result.

The treatment herein adopted relates directly to the Didlaukis and Kaden method of generalising the definitions and making the calculations very flexible. It will be shown how it is possible to obtain in detail the Mertz and Pflieger results by suitably adjusting the arbitrary

¹ Similar dispersion effects occur in the propagation of light:

A. Sommerfeld } *Annalen der Physik*, t. 44 (1914),
L. Brillouin } pp. 177 and 203.
L. Brillouin } *International Congress of Electricity*,
1932, Vol. II, p. 739.

² G. V. Bekeşy: *Annalen der Physik*, t. 19 (1934), p. 669.

³ M. Didlaukis and H. Kaden: *El. Nachrichten Technik*, t. 14 (1937), p. 13.

⁴ P. Mertz and K. W. Pflieger: *Bell System Technical Journal*, Vol. XVI (1937), p. 541.

function, termed "correlation function." The present method accordingly embraces each type of the previous calculations as a particular case.

Irregularities become evident by a local modification of the cable characteristic impedance Z as a function of the distance x from the origin. Designating Z_0 as the mean value of the impedance and taking—

$$Z(x) = Z_0 + S(x); \overline{S(x)} = 0. \tag{7}$$

S represents the local difference of impedance due to dimensional inequalities or variations in insulating materials.

The difference $S(x)$ will not vary abruptly from a point x to a neighbouring point x_1 , inasmuch as defects in manufacture or laying, as a rule, occur over an appreciable length of cable. Theoretically the products $S(x) \cdot S^*(x_1)$ of the local differences must be considered and the average taken (asterisk * in equation (8) refers to the imaginary conjugate); this average will not be zero but will depend upon the distance $|x - x_1|$ between the two points. Over a long distance no correlation exists, the variations of $S(x)$ and $S^*(x_1)$ being independent. Their individual averages being zero, there is obtained :

$$\overline{S(x) \cdot S^*(x_1)} = \overline{S(x)} \cdot \overline{S^*(x_1)} = 0. \tag{8}$$

This condition will be realised if the distance $x - x_1$ be greater than a value R , typical of the cable being considered ; or

$$|x - x_1| > R. \tag{9}$$

For shorter distances of the order R , or less, the average is no longer zero ;

$$\overline{S(x) \cdot S^*(x_1)} = \overline{|S|^2} \cdot f(x - x_1), \tag{10}$$

where $\overline{|S|^2}$ is the average square of the impedance variation S_1 taken at a given point.

The correlation function $f(x - x_1)$ plays an essential part in the entire theory : an hypothesis is necessary ; for it is only after an experimental study of different types of cable that one can check the validity of the assumptions and make a choice of the correlation function.

In the article by Didlaukis and Kaden, the whole study is based on a single particular type of correlation function. The present study elaborates on this point, the aim being to leave the choice of the type of correlation function as free as possible. A large number of essential results are obtained by making use of equations (8) and (9), according to which the correlation function is annulled at distances greater than R . By way of example, use is made of the following functions which lend themselves to simple calculation :

$$I. f(\xi) = \begin{cases} 1 & \text{when } |\xi| < r \\ 0 & \text{when } |\xi| > r \end{cases} \quad (\xi = x - x_1) \tag{11}$$

The corresponding curve is represented in Fig. 7-I with its characteristic rectangular form. This correlation yields results similar to those obtained by Didlaukis and Kaden in their study of irregularities presenting the same rectangular profile of length r .

$$II. f(\xi) = e^{-\frac{|\xi|}{r}} \tag{12}$$

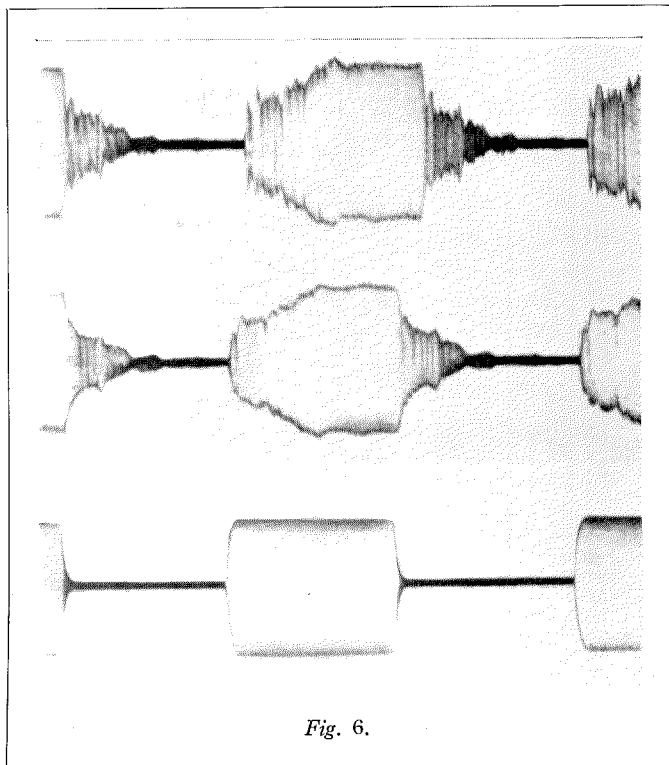

Fig. 6.

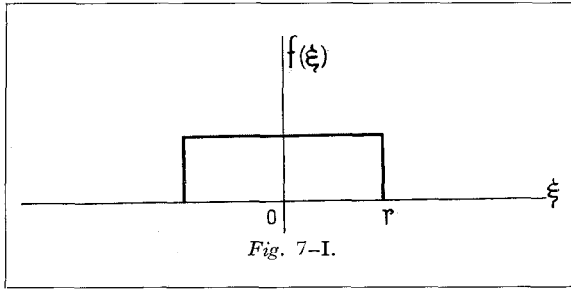

Fig. 7-I.

This is the case chosen specially by Didlaukis and Kaden, giving the profil shown in Fig. 7-II.

III.
$$f(\xi) = e^{-\frac{|\xi|^2}{2r^2}} \quad (13)$$

Gauss's classical error probability curve is represented in Fig. 7-III.

Each of the above three cases corresponds to a certain type of defect along the cable. The representative curve drops to zero at distances R of the order of $2r$ to $3r$; it will be interpreted as indicating the deformation or "standard fault" type of defect in the cable under investigation.

If several factors contribute to the irregularities in a cable, it may be expected that each individually will correspond to a different correlation law; the diverse effects will be integrated by the general law. Thus, Fig. 8 represents two types of fault:—the first, occurring frequently, is of short length r_1 ; whilst the second, occurring more rarely, produces fairly long average anomalies, r_2 .

All kinds of complexities in the correlation curve $f(\xi)$ may therefore be anticipated. The reasoning of Didlaukis and Kaden has, therefore, been followed closely here with a view to determining whether or not, and to what extent,

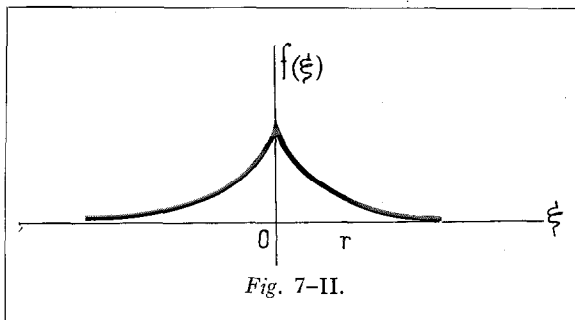

Fig. 7-II.

the effects foreseen depend on the correlation law. In any case, equation (10) merely presupposes the introduction of the absolute value $|x - x_1|$ of the distance between the two points x and x_1 ; it follows, therefore, that :

$$f(x - x_1) = f(x_1 - x). \quad (14)$$

The function f is even; the examples given here satisfy this condition.

(4) THE CORRELATION FUNCTION CORRESPONDING TO THE HYPOTHESES OF MERTZ AND PFLEGER

Consider now how the American authors' method can be fitted into this framework. Let a line be divided into equal sections of length l .

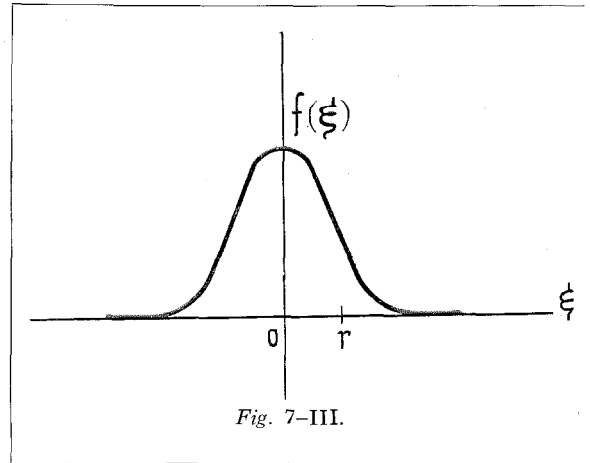

Fig. 7-III.

Each section presents an independent constant impedance; the section $(n - 1) l, n l$ will have an impedance $Z_n = Z_o + S_n$, which may be written :

$$\frac{1}{N} \sum_n S_n^2 = \overline{S^2}; \quad \sum_{n \neq m} S_n S_m = 0. \quad (15)$$

Since S is real, the asterisk (*) indicating the conjugate imaginary is omitted.

Assuming two neighbouring points on the line, separated by the distance ξ ,

$$x_2 = x_1 + \xi,$$

calculation of the correlation function is performed by adding all the products :

$$S(x_1) \cdot S(x_2) = S(x_1) \cdot S(x_1 + \xi)$$

for all possible positions of the point x_1 on the line and dividing them by the length of the line.

Taking a positive segment ξ (Fig. 9) and sliding it along the axis x , two separate cases may be distinguished :

(1) The two points x_1, x_2 are in the same section l , and have the same value as S ; then,

$$\overline{S(x_1) \cdot S(x_1 + \xi)} = \overline{S_n^2}$$

(probability $\frac{l - \xi}{l}$); (16)

(2) The two points are in two adjacent sections, the segment ξ being located at a junction; then

$$\overline{S(x_1) \cdot S(x_1 + \xi)} = 0$$

(probability $\frac{\xi}{l}$). (17)

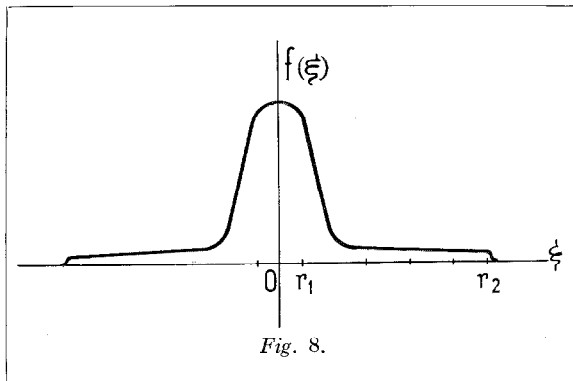
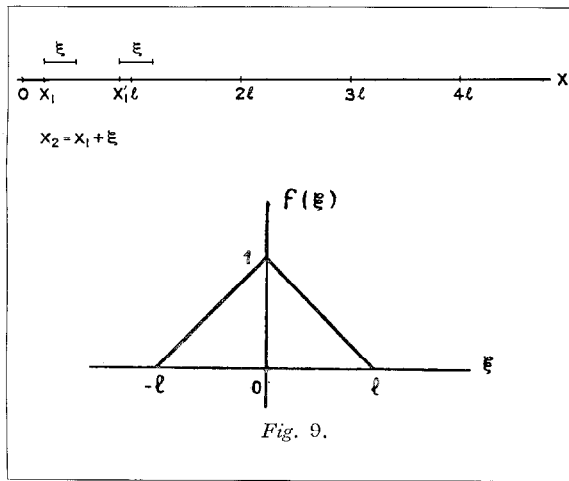

The argument here is based on a positive segment ξ , but a negative segment ξ will yield the same results; it is only the absolute value of ξ that matters.

Addition of (16) and (17) gives :

$$\overline{S(x_1) \cdot S(x_1 + \xi)} = S^2 \frac{l - |\xi|}{l}$$

IV. $\left\{ \begin{array}{l} f(\xi) = \frac{l - |\xi|}{l} \text{ when } |\xi| < l \\ \text{and } f(\xi) = 0 \text{ when } |\xi| > l. \end{array} \right\}$ (18)

This specific correlation law (case IV) corresponds to Fig. 9. It follows on cases I, II and III mentioned in connection with Fig 7. and parallels the calculations of Mertz and Pflieger.

The discussions based on the employment of the correlation formulæ apply only if the correlation does not operate at too great a distance; this restriction will be referred to in detail later. The maximum distance R (or l)

over which the correlation applies should be small compared with the length β^{-1} on which an attenuation of 1 neper is obtained. In practice the length β^{-1} is in kilometres. The reasoning pursued is therefore applicable up to correlation distances of some hundreds of metres.

(5) EXAMPLE OF THE SUPERPOSITION OF TWO CORRELATION LAWS

Let us consider a physical line comprising sections of practically equal lengths such as commercially manufactured. These lengths, for example, may be assumed to be about 230 m. For each section—say, n —there is obtained :

(1) a mean impedance $\overline{Z_n}$ slightly different from the mean Z_o of the line :

$$\overline{Z_n} = Z_o + S_n; \quad (19)$$

(2) the local differences $s(x)$, different from the mean value :

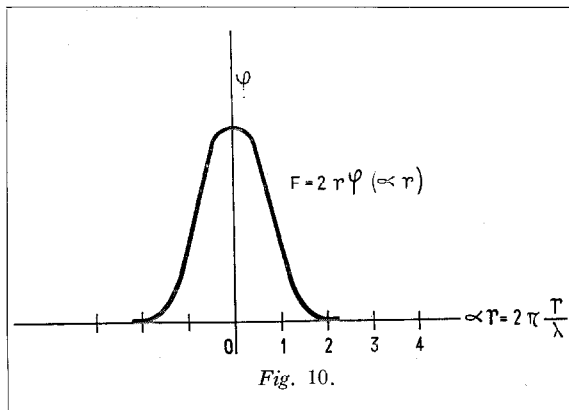

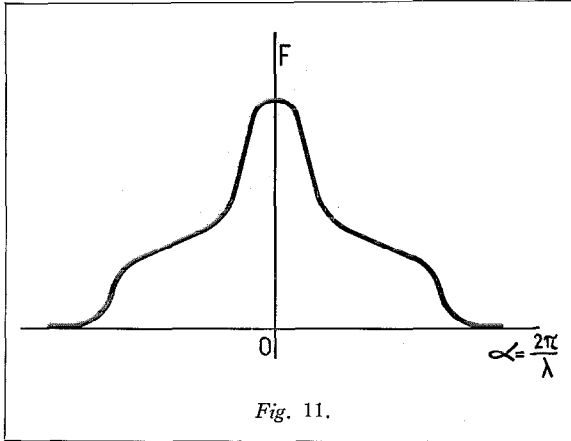

Fig. 11.

$$\left. \begin{aligned} Z(x) &= \bar{Z}_n + s(x) = Z_o + S_n + s(x) \\ S(x) &= S_n + s(x). \end{aligned} \right\} \quad (20)$$

A study of these local differences $s(x)$ gives a definite correlation law with a fairly short maximum distance of about 10 metres, as shown by the measurements of Didlaukis and Kaden.

With a cable consisting of sections of the usual length, the same correlation is obtained for all short length irregularities which occur on all the sections; the equation contains a first term with the mean square $\overline{s(x)^2}$ of the local differences defined as in (20). A second term will contain the mean square $\overline{S_n^2}$ of the mean differences of the impedances of the sections, and corresponds to a correlation function $f_{IV}(\xi)$ of type (18). The total is found to be :

$$\overline{S(x) \cdot S(x + \xi)} = \overline{s(x)^2} \cdot f(\xi) + \overline{S_n^2} \cdot f_{IV}(\xi)$$

$$f_{IV}(\xi) = \frac{l - |\xi|}{l} \quad l \approx 230 \text{ m.} \quad (21)$$

A practical example of the superposition of two correlation laws is shown diagrammatically in Fig. 8. The foregoing calculation applies to the case of chance section grouping. Actually, arrangements should always be made to group together sections having mean impedances differing only slightly (Z_n and Z_{n+1}), thereby providing for long distance correlation from section to section automatically. Thus, obviously, reflections at the junctions are decreased and advantage can be taken of the essential fact that this method of grouping greatly reduces the second term of (21). The

problem of the grouping of the sections l will be discussed further in section 18.

(6) REFLECTIONS AT CABLE IRREGULARITIES

Connecting two cables with characteristic impedances Z_1 and Z_2 , it is known that junction reflections will be produced in accordance with :

$$r = \frac{Z_2 - Z_1}{Z_2 + Z_1} = \frac{\Delta Z}{Z_2 + Z_1}. \quad (22)$$

Dealing now with a cable having small impedance irregularities: on a length dx , the impedance variation is :

$$dZ = \frac{\partial S}{\partial x} dx$$

which gives, for this element dx , a reflection of

$$dr = \frac{dZ}{2Z_o} = \frac{1}{2Z_o} \frac{\partial S}{\partial x} dx, \quad (23)$$

since $Z_1 + Z_2$ differs only slightly from its mean $2Z_o$.

Consider the propagation of a wave of frequency ω :

$$\gamma = j\alpha + \beta \quad \alpha = \frac{\omega}{W} = \frac{2\pi}{\lambda} \quad (24)$$

where α is the phase constant,
 β the attenuation constant,
 ω the frequency,
 W the phase velocity,
and λ the wave length.

After traversing the distance x , the wave is multiplied by $e^{-\gamma x}$; it is reflected in the proportion dr ; and then returns to the input of the cable with a new factor $e^{-\gamma x}$. The result is that, for a cable of length L , the wave reflected towards the input has an amplitude :

$$\begin{aligned} p(\gamma, L) &= \int_0^L e^{-2\gamma x} dr = \frac{1}{2Z_o} \int_0^L e^{-2\gamma x} \frac{\partial S}{\partial x} dx \\ &= \frac{S(L) e^{-2\gamma L} - S(0)}{2Z_o} \\ &\quad + \frac{\gamma}{Z_o} \int_0^L e^{-2\gamma x} S(x) dx. \end{aligned} \quad (25)$$

The first term relative to the ends is very small compared with the integral along the entire length of the line L ; it follows, therefore, that :

$$p(\gamma, L) \approx \frac{\gamma}{Z_0} \int_0^L e^{-2\gamma x} S(x) dx. \quad (26)$$

Accordingly, the reflection due to each element dx may be regarded as,

$$dr = \frac{\gamma S}{Z_0} dx, \quad (27)$$

rather than as given by (23). Equation (27) can easily be rederived by considering the element dx , of impedance $(Z_0 + S)$, interposed between two infinite lines Z_0 . Input and output reflections are produced at the element dx with a dephasing of $e^{-2\gamma dx} \approx 1 - 2\gamma dx$ between the two :

$$\begin{aligned} dr &= \frac{S}{2Z_0} - \frac{S}{2Z_0} e^{-2\gamma dx} \\ &= \frac{S}{2Z_0} (1 - 1 + 2\gamma dx) = \frac{S\gamma}{Z_0} dx. \end{aligned}$$

The two methods of calculation, based on (23) or (27), are therefore exactly equivalent and are in accord with equation 26.

This expression gives the amplitude of the reflected waves. To determine the intensity, the absolute value must be squared. Using an asterisk (*) to designate the conjugate imaginaries :

$$\begin{aligned} |p(\gamma, L)|^2 &= p \cdot p^* = \frac{\gamma\gamma^*}{Z_0^2} \int_0^L e^{-2\gamma x} S(x) dx \\ &\quad \int_0^L e^{-2\gamma^* x_1} S^*(x_1) dx_1; \end{aligned}$$

S being real, $S^*(x_1)$ is simply equal to $S(x_1)$. Application of the correlation law, using formula (10), gives the mean value $|\overline{p}|^2$:

$$\begin{aligned} |\overline{p(\gamma, L)}|^2 &= \frac{|\gamma|^2}{Z_0^2} |S|^2 \int_0^L e^{-2(\gamma+\gamma^*)x} dx \\ &\quad \int_0^L f(x-x_1) e^{2\gamma^*(x-x_1)} dx_1. \quad (28) \end{aligned}$$

Introducing a variable ξ equal to $x_1 - x$ and replacing dx_1 by $d\xi$, the integration of ξ accordingly extends from $-x$ to $L-x$. It is known that at a great distance the correlation function $f(\xi)$ cancels out ; and a line of length L , which is great compared with the lengths R of the cable irregularities, is assumed ; therefore,

$$F(2\gamma) = \int_{-\infty}^{+\infty} f(\xi) e^{2\gamma\xi} d\xi, \quad (29)$$

and the intensity of the reflected wave, very approximately, is :

$$\begin{aligned} |\overline{p(\gamma, L)}|^2 &= \frac{|\gamma|^2}{Z_0^2} |S|^2 F(2\gamma^*) \int_0^L e^{-4\beta x} dx \\ &= \frac{|\gamma|^2}{Z_0^2} |S|^2 F(2\gamma^*) \frac{1 - e^{-4\beta L}}{4\beta}. \quad (30) \end{aligned}$$

The whole problem is thus reduced to the evaluation of the function (29) $F(2\gamma)$. The correlations (11), (12), (13) and (18) yield the following results :

$$\begin{aligned} \text{I. } F_{\text{I}}(2\gamma) &= \int_{-r}^{+r} e^{-2\gamma\xi} d\xi \\ &= \frac{1}{\gamma} \sinh 2\gamma r \approx 2r \frac{\sin 2\alpha r}{2\alpha r} \\ \text{II. } F_{\text{II}}(2\gamma) &= \int_0^{+\infty} (e^{2\gamma\xi} + e^{-2\gamma\xi}) e^{-\frac{\xi}{r}} d\xi \\ &= \frac{1}{-2\gamma + \frac{1}{r}} + \frac{1}{2\gamma + \frac{1}{r}} = \frac{1}{\frac{1}{r^2} - 4\gamma^2} \\ &\approx \frac{2r}{1 + 4\alpha^2 r^2} \\ \text{III. } F_{\text{III}}(2\gamma) &= \int_{-\infty}^{+\infty} e^{-\frac{\xi^2}{2r^2} - 2\gamma\xi} d\xi \\ &\approx \int_{-\infty}^{+\infty} e^{-\frac{\xi^2}{2r^2} - 2j\alpha\xi} d\xi \\ &= 2r \sqrt{\pi} \cdot e^{-4\alpha^2 r^2} \\ \text{IV. } F_{\text{IV}}(2\gamma) &= \int_{-l}^0 \left(1 - \frac{|\xi|}{l}\right) \\ &\quad e^{-2\gamma\xi} d\xi + \int_0^l \left(1 - \frac{\xi}{l}\right) e^{-2\gamma\xi} d\xi \\ &= 2 \int_0^l \left(1 - \frac{\xi}{l}\right) \cosh 2\gamma\xi d\xi \\ &= -\frac{1}{2l\gamma^2} (1 - \cosh 2\gamma l) \\ &\approx \frac{1}{2l\alpha^2} (1 - \cos 2\alpha l) \\ &\approx l \left(\frac{\sin \alpha l}{\alpha l}\right)^2 \end{aligned} \quad (31)$$

For the second term of the expression F_{IV} , an integration by parts is used. The assumptions are that :

$$L \gg r \text{ or } l; \beta^{-1} \gg r \text{ or } l. \quad (32)$$

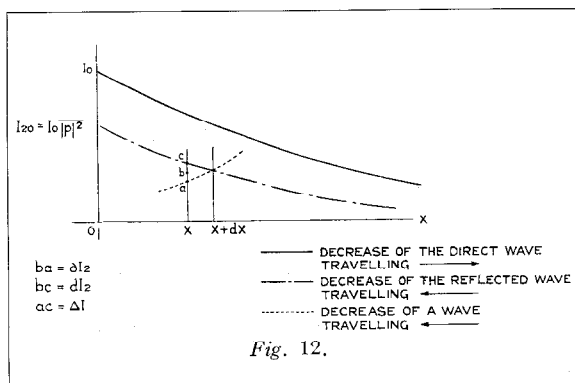

Fig. 12.

The approximation indicated by the sign \approx consists in *neglecting the attenuation on a length r* : the term βr is presumed to be negligible, account being taken only of $j \alpha r$; the cable irregularities will always be sufficiently short to justify this approximation, even if the length r or l attains some hundreds of metres.

All of the equations are of the same general type :

$$\left. \begin{aligned} F(2\gamma) &= 2r\varphi(2\alpha r) \\ 2\alpha r &= 4\pi \frac{r}{\lambda} \end{aligned} \right\}; \quad (33)$$

λ is the wavelength and r the length of the cable irregularities.

The functions φ all present maxima at the origin, and cancel out as soon as αr exceeds a certain length. Fig. 10 shows the form of the curves.

Formula (30) contains an expression which is found throughout this study and which may be termed :

$$G = \overline{|S|^2} F(2\gamma); \quad (33a)$$

it is a function of frequency and of the cable characteristics, and may be represented by the general contours of the curves of Figs. 10 or 11.

Didlaukis and Kaden give only formula (31, II)—their formula 23; no specific value can be attached to this expression. Rather more complex laws of correlation are to be expected when several distinct causes arise to produce the cable irregularities. If the function of correlation f is the sum of the two terms $f_1 + f_2$, one at a very short distance r_1 and the other at a long distance r_2 , there results the case of Fig. 9 which is considered in section (5) above.

The function F also presents itself as a sum

of two terms and corresponds in form to the curve of Fig. 11.

It is thus necessary to consider a very great variety of curves according to the nature, form and length of the cable irregularities. The proportions of the curve of Fig. 11 will be considerably modified when the wave length attains, first, the length r_2 , and then the length r_1 .

For a cable of great length L , formula (30) can be simplified since the exponential $e^{-4\beta L}$ then becomes negligible and the reflected wave attains an intensity limit :

$$\begin{aligned} \overline{|p(\gamma, \infty)|^2} &= \frac{|\gamma|^2 \overline{|S|^2}}{4\beta Z_o^2} F(2\gamma) \\ &\approx \frac{|\alpha|^2 \overline{|S|^2}}{4\beta Z_o^2} F(2\gamma) = \frac{\alpha^2 G}{4\beta Z_o^2}. \end{aligned} \quad (34)$$

In $|\gamma|^2$, only the term α^2 , which considerably exceeds β^2 , has been retained; for $F(2\gamma^*)$, $F(2\gamma)$ has been substituted since the two expressions are equal. The limit of the reflected flux thus computed for an infinite cable is designated by Didlaukis and Kaden as p^2 ; it varies inversely as the attenuation β , a fact easily understandable inasmuch as cable irregularities do not produce a sizeable reflected wave unless they occur close to the origin. Actually, only a section of length β^{-1} produces an appreciable flux reflected towards the input; for, when the length L of the cable exceeds β^{-1} , the exponential $e^{-4\beta L}$ becomes negligible and the flux reflected towards the input remains constant.

(7) IMPEDANCE VARIATIONS OF THE INPUT OF THE CABLE

A perfectly uniform cable of length L closed with its characteristic impedance has the same impedance at its input end. The relation

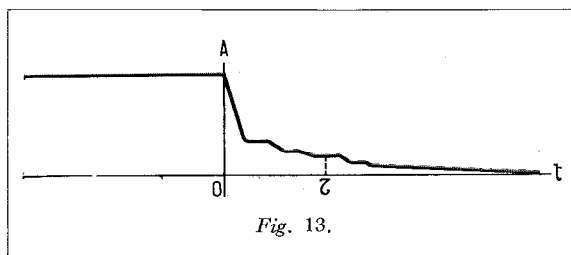
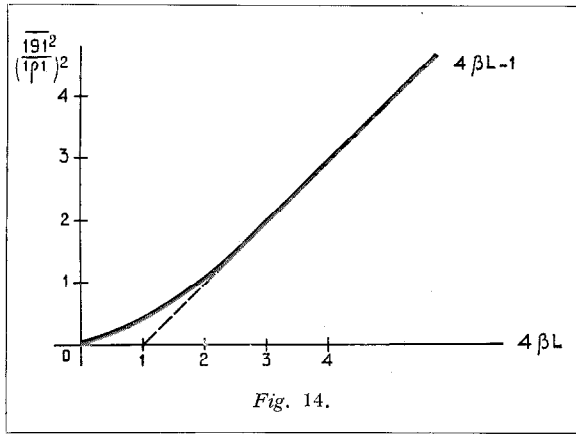

Fig. 13.



is, the fluctuation of the input resistance, disregarding the fluctuations of the imaginary component. They consider an infinitely long cable where :

$$\begin{aligned} \overline{(\Delta Z_r)^2} &= 2 \overline{|p|^2} Z_o^2 \approx \frac{\alpha^2 \overline{|S|^2}}{2\beta} F(2\gamma) \\ &= \frac{\alpha^2 G}{2\beta}. \end{aligned} \quad (40)$$

To determine the meaning of these expressions : A cable of length L will have a certain input impedance Z and, also, a well-defined difference ΔZ_r . Measurements over a large number of sections of length L (all of the same manufacturing run) may be repeated ; thus, the value of ΔZ_r and its mean square will be available. The resulting expression will conform to equation (39) or, if the length L be sufficiently great, to equation (40).

between the potential U_o and the current I_o is accordingly :

$$U_o = Z_o I_o. \quad (35)$$

If the cable is irregular, reflected waves, calculated in the preceding section, are produced. Their amplitude is $I_1 = p I_o$; the corresponding potential is :

$$U_1 = -Z_o I_1 = -p(L) Z_o I_o. \quad (36)$$

Accordingly the total input impedance is :

$$\begin{aligned} Z = Z_o + \Delta Z &= \frac{U_o + U_1}{I_o + I_1} = Z_o \frac{1 - p(L)}{1 + p(L)} \\ &\approx Z_o (1 - 2p(L)) \end{aligned} \quad (37)$$

and

$$\Delta Z = -2p(L) Z_o; \quad (38)$$

$p(\gamma, L)$ is the magnitude calculated in (26). The mean square $\overline{|\Delta Z|^2}$ of the fluctuations of the input impedance must now be ascertained ; it should be noted that Z_o is real but that ΔZ is complex like p . Distinguishing between the real and imaginary portions :

$$\Delta Z = \Delta Z_r + j \Delta Z_i \text{ and } \overline{|\Delta Z|^2} = \overline{(\Delta Z_r)^2} + \overline{(\Delta Z_i)^2}.$$

According to the laws of chance, these two mean squares will be equal ; and, making use of equation (30) :

$$\begin{aligned} \overline{|\Delta Z|^2} &= 2 \overline{(\Delta Z_r)^2} = 4 Z_o^2 \overline{|p(L)|^2} \\ &= \frac{|\gamma|^2 \overline{|S|^2}}{\beta} F(2\gamma) \left[1 - e^{-4\beta L} \right]. \end{aligned} \quad (39)$$

Didlaukis and Kaden assume that only the real component ΔZ_r is to be measured ; that

Mertz and Pflieger base their calculations, as previously mentioned, on the hypothesis of homogenous sections of equal length ; they tend towards a general equation (eq. 7 and 8, p. 550) giving the mean squares of the real components E_{br} and imaginaries E_{bi} of the reflected wave. The correspondence of their notations and the present author's is as follows :

$$\left. \begin{aligned} h &= \frac{S}{2 Z_o}, \\ \varphi &= -2 \alpha l, \\ B &= e^{-\epsilon} = e^{-2\beta l}, \\ p(\gamma) &= E_b = E_{br} + j E_{bi} \end{aligned} \right\} \quad (41)$$

The calculation is made for a line of infinite length L and yields :

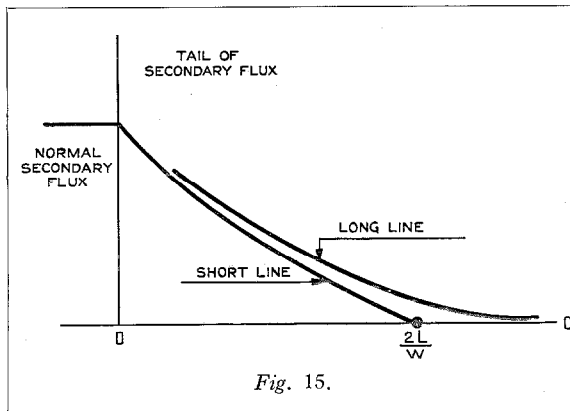

$$\left. \begin{aligned} \overline{E_{br}^2} &= \frac{\overline{h^2}}{2} \left\{ \frac{1 - 2B \cos 2\alpha l + B^2}{1 - B^2} + \frac{1 - B^2}{1 + 2B \cos 2\alpha l + B^2} \right\}, \\ \overline{E_{bi}^2} &= \frac{\overline{h^2}}{2} \left\{ \frac{1 - 2B \cos 2\alpha l + B^2}{1 - B^2} - \frac{1 - B^2}{1 + 2B \cos 2\alpha l + B^2} \right\}. \end{aligned} \right\} \quad (42)$$

In this form, the expressions are valid for sections of any length l . Introducing the assumptions indicated in (32), and taking into consideration the fact that the attenuation on short section of length β^{-1} is very small:

$$B = e^{-2\beta l} = 1 - 2\beta l; \quad l \ll \beta^{-1}.$$

On the other hand, dephasing of $2\alpha l$ may be important; in this case, equation (42) becomes:

$$\begin{aligned} \overline{E_{br}^2} = \overline{E_{bi}^2} &= \frac{\overline{h^2}}{4\beta l} (1 - \cos 2\alpha l) \\ &= \frac{|S|^2}{16Z_o^2} \frac{1 - \cos 2\alpha l}{\beta l} = \frac{|\overline{p}|^2}{2}. \end{aligned} \quad (43)$$

These equations can be reconciled with those herein developed: taking the general equation (34) and substituting the function F_{IV} (eq. 31.IV), which corresponds to the correlation law IV of Mertz and Pflieger:

$$\begin{aligned} |\overline{p}|^2 &= \frac{\alpha^2 |S|^2}{4\beta Z_o^2} F_{IV}(2\gamma) \\ &= \frac{\alpha^2 |S|^2}{4\beta Z_o^2} \frac{1}{2\alpha l} (1 - \cos 2\alpha l) \\ &= \frac{|S|^2}{8\beta Z_o^2 l} (1 - \cos 2\alpha l). \end{aligned} \quad (44)$$

Agreement between equations (44) and (43) is complete. Mertz and Pflieger, in their applications, have assumed very short sections, even compared with the wave length; they accordingly take—

$$l \ll \alpha^{-1}, \quad \varphi \ll 1,$$

a condition which is much more restrictive than has been found necessary for the present calculations. Equation (44) accordingly reduces to:

$$|\overline{p}|^2 = \frac{\alpha^2 l}{4\beta Z_o^2} |S|^2. \quad (45)$$

The author prefers to retain expression (44) which may be applied to much longer sections

l without complicating the calculations. The variation of the real component of the input impedance, in the case under consideration, is:

$$(\Delta Z_r)^2 = \frac{|S|^2}{4\beta l} (1 - \cos 2\alpha l). \quad (46)$$

(8) COMPLEMENTARY ATTENUATION OF DIRECT WAVES DUE TO CABLE IRREGULARITIES

Considering wave propagation along a very long cable, $L \gg \frac{1}{4\beta}$, it is clear that reflections due to irregularities produce energy losses and, consequently, a complementary attenuation. The latter will now be evaluated.

The direct wave has an amplitude $A_1(x)$ and an intensity $I_1(x)$ given by:

$$\begin{aligned} A_1(x) &= A_o e^{-\gamma x}; \quad I_1(x) = |A_1|^2 \\ &= I_o e^{-2\beta x}. \end{aligned} \quad (47)$$

At each point x , the derivations of section 6 may be applied since the cable is very long. The reflected wave of mean intensity I_2 may be represented by the term:

$$\begin{aligned} I_2(x) &= \frac{|\overline{p}(\gamma, \infty)|^2}{|\overline{p}(\gamma, \infty)|^2} I_1(x) \\ &= |\overline{p}(\gamma, \infty)|^2 I_o e^{-2\beta x}, \end{aligned} \quad (48)$$

where $|\overline{p}|^2$ is given by equation (34). While the equation was derived for the input of a cable ($x=0$), it is applicable without change at any point whatsoever. At a segment dx , a variation dI_2 occurs; or,

$$dI_2 = -2\beta I_2 dx. \quad (49)$$

It should be noted that the direct wave is propagated from right to left towards the negative x (reflected wave). If the usual type of attenuation only were under consideration, it would be found that:

$$\delta I_2 = +2\beta I_2 dx. \quad (50)$$

Fig. 12 illustrates this reasoning.

In order to maintain the distribution represented by (32), it is therefore necessary to supply to the reflected wave a mean energy of

$$\Delta I = -d I_2 + \delta I_2 = 4 \beta I_2 dx . \quad (51)$$

This energy is necessarily taken from the direct wave and introduces a new term β' in the mean attenuation of the amplitude, yielding a complementary attenuation $2 \beta'$ of intensity I_2 :

$$\begin{aligned} \beta' &= \frac{\Delta I}{2 I_1 dx} = 2 \beta \frac{I_2}{I_1} = 2 \beta \overline{[p(\gamma, \infty)]^2} \\ &= \frac{\alpha^2 \overline{|S|^2}}{2 Z_o^2} F(2 \gamma) , \end{aligned} \quad (52)$$

use being made of equation (34). Through equation (40) this complementary attenuation may be expressed in terms of the variations ΔZ_r of the real part of the entrance impedance:

$$\beta' = \beta \left(\frac{\Delta Z_r}{Z_o} \right)^2 . \quad (53)$$

This result can be derived by direct calculation by evaluating the reflected intensity for a segment dx . Considering a very long cable, $-L$ to $+L$, and in particular the segment comprised between $x = O$ and dx , the reflection dx in terms of amplitude is given by (27); thus the amplitude of the reflected wave at this segment is:

$$d A_2 = A_1 dr = A_1 \frac{\gamma}{Z_o} S(O) dx . \quad (54)$$

This wave dA_2 is added to a reflected wave, already present, the amplitude A_2 of which is, therefore, none other than $A_1 p(\gamma, \infty)$ of (26).

The increase of ΔI_2 of the reflected energy or intensity is therefore obtained by the following expression, which represents the complementary energy $-\Delta I_1$ due to the reflected wave dA_2 :

$$\begin{aligned} \Delta I_2 &= d(A_2 A_2^*) = A_2 dA_2^* + A_2^* dA_2 \\ &= I_1 \frac{|\gamma|^2}{Z_o^2} dx \int_0^L [S^*(O) \cdot S(x_1) e^{-2\gamma x_1} \\ &+ S(O) S^*(x_1) e^{-2\gamma^* x_1}] dx_1 . \end{aligned} \quad (55)$$

The integral extends from O to L or, actually, from O to ∞ , and includes all the segments of line x_1 to the right of the origin, contributing to form the reflected wave which arrives at the segment dx . On an average, the products $S.S^*$ may be evaluated by the correlation

law (10):

$$\begin{aligned} \Delta I_2 &= I_1 dx \frac{|\gamma|^2 \overline{|S|^2}}{Z_o^2} \\ &= \int_0^\infty f(\xi) [e^{-2\gamma\xi} + e^{-2\gamma^*\xi}] d\xi \\ &= I_1 dx \frac{|\gamma|^2 \overline{|S|^2}}{Z_o^2} F(2\gamma) . \end{aligned} \quad (56)$$

Here the integral (29) occurs again in equivalent form. Further, the last result is identical to (52), taking (48) and (34) into account:

$$\Delta I_2 = -\Delta I_1 = 2 \beta' I_1 dx . \quad (57)$$

It is easily explained: the increase of the intensity dI_2 is furnished, on the average, only by the terms $A_2 dA_2^*$ or $A_2^* dA_2$, involving a certain phase correlation; the integral $F(2\gamma)$ of (29) hence reappears in a correlation zone.

Thus there is obtained, as equation (53), the first result of this study: any irregularity in cable causes loss of energy by reflection; whence an increase in the mean attenuation results. In order to reduce attenuation and other electrical losses in a cable, extremely accurate and painstaking methods of manufacture, as well as robust construction, therefore, are required. All cable irregularities must be avoided. Practical implications and admissible tolerances will be considered subsequently.

(9) THE REFLECTED WAVE AT THE ENTRANCE OF THE CABLE: ITS ESTABLISHMENT AND DECAY

All the calculations apply to the case where the wave transmitted into the cable has been established for a period long enough to enable it to pass through an entire section of a length $1/\beta$. As already seen, this length of cable plays an essential part in the formation of the reflected wave.

The manner in which the reflected wave is established at the beginning of a signal and its progressive diminution after the completion of the signal will be investigated. The wave velocity along the cable is:

$$W = \frac{\omega}{\alpha} = \frac{\lambda}{\tau} ; \alpha = \frac{2\pi}{\lambda} ; \omega = \frac{2\pi}{\tau} ; \quad (58)$$

where λ is the wave length, and τ the period.

Let us assume a signal ω established at the instant $t = O$; after a period $1/2 t$, this signal

will be propagated along the cable a distance

$$L = 1/2 Wt, \quad (59)$$

and the signals reflected by this cable section L will revert to the origin of the cable at the instant t ; equation (30), therefore, will give the law for the *establishment of the reflected wave* when (59) is substituted:

$$\overline{|p(\gamma, t)|^2} = \frac{\alpha^2 |S|^2}{4 \beta Z_0^2} F(2\gamma) [1 - e^{-2\beta Wt}] \quad (60)$$

Consider now the law of decay on a cable of infinite length when the signal is interrupted at the instant $t=0$. After a time $1/2t$, the tail of the signal arrives at the distance L from the origin (equation 59). At this point the signal has an amplitude $e^{-\beta L}$ reduced by the attenuation. The reflected wave, therefore, has an intensity represented by (34) but is influenced by a factor $e^{-2\beta L}$; this reflected wave, furthermore, covers a distance L to reach the input of the cable and arrives there at the moment t ; its intensity, therefore, is again reduced by $e^{-2\beta L}$, the law of decrease after the completion of the signal being

$$\begin{aligned} \overline{|p(\gamma, t)|^2} &= \overline{|p|^2} e^{-4\beta L} \\ &= \frac{\alpha^2 |S|^2}{4 \beta Z_0^2} F(2\gamma) e^{-2\beta Wt}. \end{aligned} \quad (61)$$

The increase (60) and the decrease (61) of the mean *intensities* of the reflected waves are accordingly exactly symmetrical.

This result can be arrived at directly by reasoning similar to that of section 2 (equation 6). It applies only on the average, and on the hypothesis that the irregularities along a cable are sufficiently regular to produce a large number of partial components of the reflected wave, these components having all sorts of phases.

There nevertheless will exist between the *complex amplitudes* a strict relation of type (4) or (4a) (section 2), even in the case of a small number of reflected components.

Analogous conditions are encountered in the establishment or diminution of sound in a hall when multiple reflections producing reverberation are considered. In the electrical example, as in acoustics, the exponential laws of increase and decrease apply only on an average, while the laws observed experimentally show numer-

ous deviations from the average; increase and decrease correspond very exactly despite the influence of dephasing. The contours of the curves resemble the types shown in Figs. 3 and 6 very closely.

(10) DOUBLY REFLECTED WAVE TOWARDS THE OUTPUT OF THE CABLE

The present study has made it possible to deal fairly rapidly with the problem of double reflection of the type depicted in Fig. 2. Consider the part played by an irregularity at x , reflecting the wave in a backward direction; the wave encounters a second irregularity at x' , reflecting it forward. The direct and reflected waves thus traverse a distance $2(x-x')$. The calculation will be made, in the first instance, for all irregularities for which the distance $x-x'$ is greater than l_1 : that is,

$$x-x' \geq l_1. \quad (62)$$

All these pairs of irregularities yield a flux which reaches the output end with a delay of at least

$$\tau = \frac{2 l_1}{W}, \quad (63)$$

W being the velocity of propagation. Any pairs where $x-x'$ is less than l_1 give a reflected flux which arrives at the output of the cable prior to the instant τ .

Assume a signal ω established from the time $t=-\infty$, and interrupted as from the instant $-T$ (delay of propagation over the length of the line), such that the principal signal is interrupted at $t=0$ at the output of the line. At the latter, a signal tail develops analogous to that of Fig. 13. Calculation of the reflections at the pairs of irregularities satisfying condition (62) give the intensity of this signal tail at the instant τ ; actually, the signal having been interrupted at $t=0$, the only reflected waves arriving at τ are those produced prior to $t=0$, and correspond to (62).

Taking a line of length L on which a wave ω of amplitude A_0 is imposed at the input, its amplitude at the output is:

$$A_0(L) = A_0 e^{-\gamma L}.$$

The first wave reflected at x is:

$$A_1(x) = A_0 e^{-\gamma x} \frac{\gamma}{Z_0} S(x) dx. \quad (64)$$

The reflection at x is given by (27); at x' (whence the factor $e^{-\gamma(x-x')}$), it is reflected a second time :

$$A_2(x') = A_1 e^{-\gamma(x-x')} \frac{\gamma}{Z_0} S(x') dx' = \frac{\gamma^2}{Z_0^2} A_0 e^{-2\gamma x + \gamma x'} S(x) \cdot S(x') dx dx'. \quad (65)$$

Finally, the section $L - x'$ must be considered in order to obtain the reflected wave at the output :

$$A_2(L) = \frac{\gamma^2}{Z_0^2} A_0 e^{-\gamma L} e^{-2\gamma(x-x')} S(x) \cdot S(x') dx dx' \quad (66)$$

Integrating x from l_1 to L , and taking for x' the limiting values $x' = 0$ and $x - l_1$ in accordance with the foregoing, it is necessary that x should be at least equal to l_1 in order that the conditions postulated should be realised.

The relative amplitude of the reflected wave at the output is then :

$$q(\gamma, l_1, L) = \frac{A_2(L)}{A_0(L)} = \frac{\gamma^2}{Z_0^2} \int_{x=l_1}^{x=L} dx \int_{x'=0}^{x'=x-l_1} dx' S(x) e^{-\gamma x} S(x') e^{+\gamma x'} = - \int_{x=l_1}^{x=L} p(-\gamma, x-l_1) \frac{\partial}{\partial x} p(\gamma, x) dx \quad (67)$$

Making use of the notation $p(\gamma, L)$ defined by equation (26) :

$$\frac{\partial}{\partial x} p(\gamma, x) = \frac{\gamma}{Z_0} e^{-2\gamma x} S(x)$$

$$p(-\gamma, x-l_1) = - \frac{\gamma}{Z_0} \int_0^{x-l_1} e^{2\gamma x'} S(x') dx'$$

(11) MEAN INTENSITY OF THE WAVE TAIL

The intensity of the wave rather than its amplitude requires evaluation. It is expressed by the product of the conjugate imaginaries :

$$|q|^2 = q \cdot q^* = \int_{l_1}^L p(-\gamma, x-l_1) \frac{\partial}{\partial x} p(\gamma, x) dx \int_{l_1}^L p(-\gamma^*, x_1-l_1) \frac{\partial}{\partial x_1} p(\gamma^*, x_1) dx_1. \quad (68)$$

In the determination of the mean value of this quantity, the laws of correlation apply in a

form similar to that of section (6); certain supplementary hypotheses nevertheless are necessary.

Four quantities are subject to chance variation : the two p 's and two $\frac{\partial p}{\partial x}$'s. Values of $\frac{\partial p}{\partial x}$ are independent of p ; that is, $\frac{\partial p}{\partial x}$ is a local effect, while p depends on integration over the whole cable. Correlation between the two $\frac{\partial p}{\partial x}$'s, as in (28) to (30), is thus possible; hence,

$$\frac{\partial p}{\partial x} \cdot \frac{\partial p_1^*}{\partial x_1} = \frac{|\gamma|^2}{Z_0^2} |S|^2 f(x-x_1) e^{-2(\gamma+\gamma^*)x} e^{2\gamma^*(x-x_1)}. \quad (69)$$

Introducing a new variable ξ :

$$\xi = x - x_1 \text{ and } 2(\gamma + \gamma^*)x = 4\beta x.$$

The variable ξ must be small since the function of correlation f is cancelled out at distances greater than R , and R has been assumed to be fairly small.

Taking the product of the two functions p :

$$p(-\gamma, x-l_1) p(-\gamma^*, x_1-l_1) = p(-\gamma, x-l_1) p(-\gamma^*, x-\xi-l_1) = \frac{\gamma\gamma^*}{Z_0^2} \int_0^{x-l_1} e^{2\gamma x'} S(x') dx' \int_0^{x-\xi-l_1} e^{2\gamma^* x'_1} S(x'_1) dx'_1,$$

and transforming this expression as in (28) by introducing a variable ξ' :

$$\xi' = x'_1 - x' \quad \overline{S(x') \cdot S(x'_1)} = |S|^2 f(\xi'), \quad p(-\gamma, x-l_1) \cdot p(-\gamma^*, x_1-l_1) = \frac{\gamma\gamma^*}{Z_0^2} |S|^2 \int_0^{x-l_1} e^{2(\gamma+\gamma^*)x'} dx' \int_{-x'}^{x-l_1-x'-\xi} f(\xi') e^{2\gamma^*\xi'} d\xi' \approx \frac{|\gamma|^2 |S|^2}{4\beta Z_0^2} F(-2\gamma) [e^{4\beta(x-l_1)} - 1]. \quad (70)$$

It is, in fact, possible in the second integral to replace the limits $-x'$ and $x-l_1-x'-\xi$ by $-\infty$ and $+\infty$ since the function $f(\xi')$ is eliminated as soon as the distances exceed the distance of correlation. Integrals are therefore obtained similar to those of (28), (29) and (30).

The approximations introduced in (70) are based on ξ' and ξ being small compared with l_1 ; that is, the distance l_1 is greater than the correlation distance R . Considerations applying to these approximations will be discussed later.

The mean value of equation (68) now takes the following form :

$$\overline{|q(\gamma, l_1, L)|^2} = \frac{|\gamma|^4}{4 \beta Z_o^4} \left(\overline{|S|^2} \right)^2 F(-2\gamma) \int_{l_1}^L e^{-4\beta x} \cdot [e^{4\beta(x-l_1)} - 1] dx \int_{-\infty}^{+\infty} f(\xi) e^{2\gamma*\xi} d\xi. \quad (71)$$

The integral at x should be taken from $x = l_1$ and not from $x = O$, since the expression to be integrated is zero at $x = l_1$. The integral at ξ may be extended in practice from $-\infty$ to $+\infty$ as in (29); it then gives the value $F(-2\gamma^*)$, but F is insensitive to changes in sign and the imaginary part of γ :

$$F(-2\gamma) = F(-2\gamma^*) = F(2\gamma).$$

The integral at x is easily obtained with the precaution regarding the lower limit l_1 . Finally, the following is obtained :

$$\begin{aligned} \overline{|q(\gamma, l_1, L)|^2} &\approx \left(\frac{|\gamma|^2 \overline{|S|^2} F(2\gamma)}{4 \beta Z_o^2} \right)^2 [e^{-4\beta L} - e^{-4\beta l_1} + 4 \beta (L - l_1) e^{-4\beta l_1}] \\ &\approx \left(\overline{|p(\gamma, \infty)|^2} \right)^2 [e^{-4\beta L} - e^{-4\beta l_1} + 4 \beta (L - l_1) e^{-4\beta l_1}]. \quad (72) \end{aligned}$$

It will be seen that equation (34) squared appears as a factor.

In (70), a discrepancy of the order of R occurs in evaluating the distances $x - x_1 = l_1$; (71), using infinity for the limits, ceases to be correct when the actual limits

$$\xi = -x \text{ and } L - x$$

are not very great; here again, an inaccuracy of the order of R (distance of correlation) may be introduced in connection with the variable x ; consequently, the distance l_1 , determining the lag in arrival of the tail of the signal, may be incorrect by a value of the order of R .

The following conclusions, in the opinion of the author, can be drawn: equation (72) should be correct where it gives a result which varies slowly as a function of l_1 ; it becomes somewhat questionable when a sudden variation is indicated.

Taking l_1 as zero in the foregoing equations, a doubly reflected flux accompanying the direct wave is obtained. The total secondary flux is:

$$\overline{|q(\gamma, O, L)|^2} = \left(\overline{|p(\gamma, \infty)|^2} \right)^2 [e^{-4\beta L} - 1 + 4 \beta L]. \quad (73)$$

Fig. 14 shows the variation of this expression as a function of the length L of the cable. For great lengths ($4 \beta L \gg 1$), the variation becomes linear; the secondary flux, under the conditions mentioned, is proportional to the length L of the cable. Here, as in the preceding problems, a long cable is defined as one with a high coefficient of attenuation βL . All ordinary cables fall in this category unless they are extremely short.

(12) ESTABLISHMENT AND DECREASE OF THE SECONDARY FLUX

The derived equations give directly the form of the curve for the establishment of the secondary wave, and the manner in which it becomes attenuated progressively subsequent to the completion of the direct signal.

Considering a specific value l_1 (equation 62), a corresponding doubly reflected wave traverses a supplementary path $2 l_1$, and reaches the end of the cable with a delay τ equal to $\frac{2l_1}{W}$ (equation 63). Assuming an established direct signal of frequency ω , suddenly interrupted so that the end of the direct signal reaches the extremity of the line at the instant $t = O$, the secondary flux is maintained for an interval; a signal tail results. Its intensity at the moment τ is represented by (72);

$$\overline{|q(\gamma, \tau, L)|^2} = \left(\overline{|p(\gamma, \infty)|^2} \right)^2 [e^{-4\beta L} - e^{-2\beta W\tau} + 2\beta (2L - W\tau) e^{-2\beta W\tau}] \quad (74)$$

For a short line, the initial decrease is almost exponential, dropping to zero when

$$\tau_{\max} = \frac{2L}{W}.$$

For a long line, the only important term in the brackets is $4 \beta L e^{-2\beta W\tau}$, which shows an exponential decrease (Fig. 15). The time constant of the signal tail for the square root of the mean intensity is :

$$\theta = \frac{1}{\beta W} = \frac{\alpha}{\omega \beta}, \tag{75}$$

the same as for the establishment and decay of the reflected flux towards the entrance of the line (equations 58 and 61).

On establishing the signal, a symmetrical increasing curve will be obtained ($e^{-2\beta W\tau} - 1$); Fig. 16 depicts the different curves and their superposition for the formation of the total flux received at the output of the cable.

In discussing approximations, it has been shown that the equations are valid only as an *average*. The real curve of growth and decay of the actual flux may show a fairly considerable fluctuation round the mean curve; moreover (equations 72 and 73), inaccuracies were introduced in evaluating l_1 , amounting to R (distance of correlation or mean length of cable irregularities). It is, therefore, necessary to take into

account discrepancies of about $\frac{2R}{W}$ in the values

of τ , which may modify the form of the signal seriously, particularly when sharp angles obtain at the beginning and end of the main signal. The places where the curve in Fig. 16 appear questionable have been shown by cross-hatching.

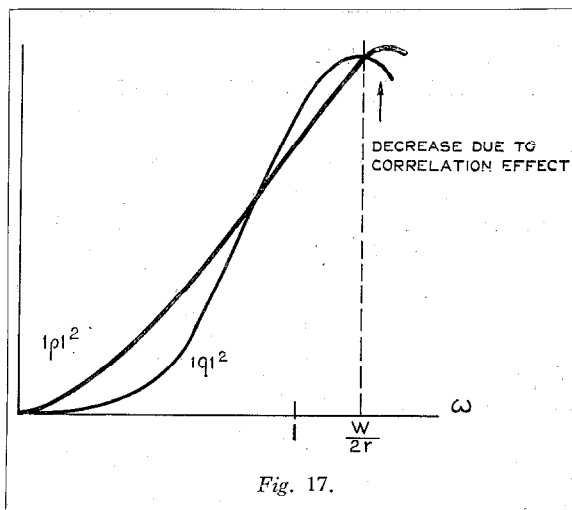

Fig. 17.

(13) RECAPITULATION OF THE ESSENTIAL RESULTS

For convenience in practical consideration, Table I summarises the essential data and results obtained in the present study. A large proportion of the equations have been published by Didlaukis and Kaden; their reasoning, however, is based on assumptions which are much less general than those herein applied. The law of correlation occurs explicitly only in the integral F ; it apparently cancels out in other relations, but all the complete explicit equations contain a factor F or F^2 . By suitable application of the law of correlation the equations, as previously indicated, can be made to include all the essential calculations of Mertz and Pfefer.

The following important facts are of interest :

Studying the formation of the reflected wave towards the entrance of the line, the co-efficient of attenuation β attenuates the waves reflected at the line irregularities. In practice, a reflected wave results solely from reflections produced on a length approximately β^{-1} from the origin; any reflection from an irregularity at a distance x greater than β^{-1} (Fig. 1) is negligible.

A wave reflected at the input, therefore, is produced over a portion of line β^{-1} adjacent to the origin. A wave which is doubly reflected towards the output is disposed progressively over the whole line, a fact explaining the presence of a factor proportional to the length L of the line. Starting from an irregularity x (Fig. 2), a wave reflected towards the rear must

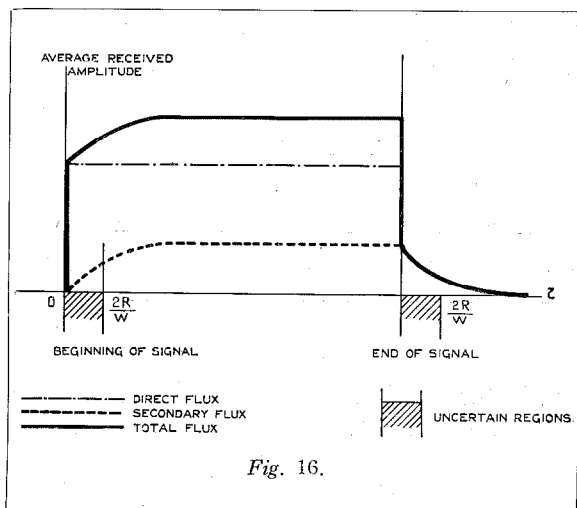

Fig. 16.

TABLE I
ESSENTIAL RESULTS FOR LONG LINES

Long line : $4\beta L \gg 1$
 Propagation constant : $\gamma = j\alpha + \beta$
 Mean characteristic of line impedance : Z_0
 Local difference in impedance in relation to Z_0 : $S(x)$ (7)
 Law of Correlation $\overline{S(x) \cdot S^*(x_1)} = \overline{|S|^2} f(x - x_1)$ (10)
 The function f represents the form of the "standard irregularity" and is eliminated at great distances :
 $|x - x_1| > R$ (9)
 R , distance of correlation ; examples are given in (11), (12), (13), (18).
 The fundamental integral :

$$F(2\gamma) = \int_{-\infty}^{+\infty} f(\xi) e^{-\gamma\xi} d\xi \quad (29) \text{ to } (31)$$

Mean reflected flux towards the entrance of a long line :

$$\overline{|p(\gamma, \infty)|^2} = \frac{\alpha^2 \overline{|S|^2}}{4\beta Z_0^2} F(2\gamma) = \frac{\alpha^2 G}{4\beta Z_0^2} \quad (34)$$

where $G = \overline{|S|^2} F(2\gamma)$.
 Variations ΔZ_r of the real impedance term at the input of a long line :

$$\left(\frac{\Delta Z_r}{Z_0}\right)^2 = 2 \overline{|p(\gamma, \infty)|^2} \quad (40)$$

Supplementary attenuation of the direct wave by reflection at cable irregularities :

$$\beta' = 2\beta \overline{|p(\gamma, \infty)|^2} = \beta \left(\frac{\Delta Z_r}{Z_0}\right)^2 \quad (52) (53)$$

Mean doubly reflected flux towards the output, accompanying the direct signal, on a long line :

$$\overline{|q(\gamma, 0, L)|^2} = \left(\overline{|p(\gamma, \infty)|^2}\right)^2 4\beta L = \left(\left(\frac{\Delta Z_r}{Z_0}\right)^2\right)^2 \beta L \quad (73)$$

The flux reflected towards the input and that accompanying the direct signal have a duration of establishment and lag (amplitude) :

$$\theta = \frac{1}{\beta W} = \frac{\alpha}{\omega\beta} \quad (75)$$

where W is the velocity of propagation $\frac{\omega}{\alpha}$ of the waves.

encounter another irregularity x_1 at a distance less than β^{-1} , if the energy contribution of the reflected wave at the output is to be appreciable. Thus, in the two cases, one can perceive the essential part played by the length β^{-1} and the duration $\theta = (\beta W)^{-1}$, which represents the time consumed by the waves in traversing the length β^{-1} . The duration θ represents the time taken to establish the phenomenon and the time of lag. It is an essential condition and one

which cannot be modified, inasmuch as β and W are completely defined as soon as the type of cable is fixed.

(14) INFLUENCE OF FREQUENCY : CHARACTERISATION OF THE IMPORTANCE OF THE WAVE TRAIN

In order to discuss the influence of frequency, it may be recalled that α varies with ω , and β with $\sqrt{\omega}$:

$$\alpha = \frac{\omega}{W} = \frac{2\pi}{\lambda} ; \beta = C \omega^{\frac{1}{2}} \quad (76)$$

Moreover, the integral function $F(2\gamma)$ remains constant and equal to $2r$ for all low frequencies ; it decreases fairly rapidly when the wave length becomes about the same as the distance of correlation r . Since $2\gamma r$ appears in the function F , this condition may be written :

$$2\alpha r \approx 1 ; \omega \approx \frac{W}{2r} \quad (77)$$

Nothing is known "a priori" relative to this distance of correlation r . Didlaukis and Kaden found a length r of about 10 metres for the cable which they studied⁵ ; on other cables, this length may be very different. Several distances of correlation may appear and the function F may decrease by stages, as shown in Fig. 11 and as discussed in section 5. If r be taken equal to 10 m., $\lambda = 120$ m. It is scarcely possible, therefore, to know "a priori" what will occur in the case of wave lengths of around 100 m. ; that is, for frequencies of about 3×10^6 cycles, since correlation plays a very definite part. Up to frequencies of about 10^6 cycles, F may be considered constant ; examination of the equations of Table I gives the following laws of variation :

F	$\overline{ p ^2}$	$\left(\frac{\Delta Z_r}{Z_0}\right)^2$	β'	$\overline{ q ^2}$	θ
constant	$\omega^{3/2}$	$\omega^{3/2}$	ω^2	$\omega^{7/2} L$	$\omega^{-1/2}$

(78)

With correlation distances of about 10 metres, it will be seen that beyond 3×10^6 cycles the

⁵ This order of magnitude was also found in a coaxial cable manufactured by L.T.T. (December, 1937).

growth of $|p|^2$ and $|q|^2$ becomes slower, passes a maximum, and then decreases. Actual values, however, are hypothetical, the construction of the cable playing an essential role (Fig. 17).

Consideration must be given to the case where two types of irregularities occur with two distinct correlation distances. In the example in section 5, localised irregularities are assumed with a correlation distance of about 10 m., as well as extended irregularities, resulting in variations in mean impedance between different sections of cable. This second type of irregularity follows a different law as a function of the frequency.

The flux $|q|^2$ accompanying the direct signal is initially very small at low frequencies, inasmuch as it is of the second order, compared with first order effects, such as the reflected flux $|p|^2$. At high frequencies, the flux $|q|^2$ becomes greater. Attention must be paid to the duration of the signal tail, θ , and the total intensity of the tail of the signal :

$$Q = \int_0^\infty |q|^2 e^{-\frac{2t}{\theta}} dt = \frac{\theta |q|^2}{2} = |q|^2 \frac{1}{2\beta W} \quad (79)$$

$$Q \approx \omega^3 L.$$

The duration of the signal tail, θ , decreases at high frequencies so that the total intensity Q of the tail of the signal increases slightly less rapidly than the intensity $|q|^2$ of the normal flux (Fig. 18).

In Fig. 16 certain zones are indicated where the theory appears to introduce fairly considerable inaccuracies (shaded portions). These zones, however, are very restricted and correspond to durations even smaller than television signals. Actually, they involve a duration of $\frac{2r}{W}$, where r is the distance of correlation or length of cable irregularity. Hence, $2r$ would be about 20 metres or $\frac{2r}{W}$, a duration of approximately 10^{-7} seconds.

The phenomenon of double reflection may be characterised by the flux $|q|^2$ and by the duration of the signal tail, θ , or by a combination of these two magnitudes, as :

$$Q = \frac{1}{2} \theta |q|^2$$

defined in (79). Mertz and Pfeleger have adopted another course; they have not separated the two quantities $|q|^2$ and θ , but have directly calculated an expression "Standard deviation in envelope delay," or "envelope delay distortion." "Envelope delay" is the inverse of the group velocity U , or the time of transmission of a signal along a unit length.⁶

$$\text{Envelope delay } T = \frac{d\alpha}{d\omega} = \frac{1}{U} = \frac{d\left(\frac{f}{W}\right)}{df} \approx \frac{1}{W}. \quad (80)$$

Mertz and Pfeleger accordingly compute the square root of the mean square of the differences ΔT , resulting from the superposition of the secondary flux on the direct flux; that is, the "standard deviation in envelope delay." Instead of the square root of the mean square of the differences, the maximum difference may be taken, estimated at three times the preceding square root.

In transcribing Mertz and Pfeleger's equation, the present author has designated their "envelope delay distortion" by "D":

$$\text{Standard deviation} = \sqrt{(\Delta T)^2} = \frac{D}{3}. \quad (81)$$

The calculation, therefore, supplies an expression of the following type (Mertz, Pfeleger, p. 549, eq. 10') :

$$D = 3 \sqrt{\frac{(\Delta Z_r)^2}{Z_o^2}} = 4.42 \frac{(\Delta Z_r)^2}{Z_o^2} \cdot \tau \sqrt{\frac{L}{\beta}}$$

(in microseconds), (82)

where L = length of line in miles,
 β = attenuation in decibels per mile,
 and τ = "envelope delay" of the line in microseconds per mile.

The lines utilised have a phase velocity W almost independent of frequency, such that the group velocity U and the phase velocity W differ very slightly (equation 80). The numerical factor depends on the units chosen; if it be replaced by C , it follows that :

$$D = C \left(\frac{\Delta Z_r}{Z_o}\right)^2 \frac{1}{W} \sqrt{\frac{L}{\beta}} = C \sqrt{|q|^2} \cdot \theta. \quad (83)$$

The final expression (83) relates to a combination of two fundamental quantities $|q|^2$ and θ .

⁶ Mertz and Pfeleger use α for β and β for α in their equations.

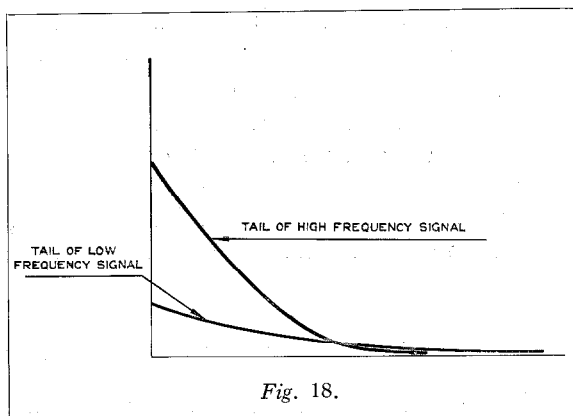

A question might be raised as to the most important expression to be considered in practice. It seems preferable, however, to consider separately the flux $|q|^2$ (equation 73) and the duration θ (equation 75), both of which play roles entirely distinct, rather than to study combinations such as Q or D (equations 79 and 83), the practical importance of which hardly seems to have been demonstrated.

(15) NUMERICAL APPLICATIONS: TELEVISION

Since the band from 0 to 1 000 kc., presumably is reserved for telephony, higher frequencies must be used for television. Calculating an image of 441 lines, a band of approximately 3 000 kc., extending from 1 000 to 4 000 kc., is required.

For a frequency of 1 000 kc., considered as the lower limit of the band, cables of different types give attenuations β varying from 0.16 to 0.5 neper per km. The following examples have been selected :

Didlaukis and Kaden, *loc. cit.* : $\beta = .16$ nepers km.

Deloraine, *Société des Electriciens T.7* (1937), p. 1057 :

11.5 mm. cable : $\beta = 2$ db. km. (.25 neper km.)

6 mm. cable : $\beta = 3.7$ db. km. (.43 neper km.)

The wave velocity in the cable is slightly less than that of light ; say

$$W = 280\,000 \text{ km : sec.}$$

All the parasitic effects increase with the frequency, at least up to frequencies of 3×10^6 cycles when the law of correlation begins to play a role. It will be seen that this extremely high frequency is utilised in the foregoing example. Towards the maximum frequency of

4×10^6 cycles the influence of the secondary flux, accompanying the signal and the wave train, requires consideration. The duration θ of the wave tail attains the values indicated in (84) for various frequencies f and various attenuations β taken at 10^6 cycles.

β at 10^6 cycles	Values of θ	
	for $f = 10^6$	for $f = 4 \times 10^6$
Nepers per km.	Seconds	Seconds
0.1	$3.6 \cdot 10^{-5}$	$1.8 \cdot 10^{-5}$
0.2	$1.8 \cdot 10^{-5}$	$0.9 \cdot 10^{-5}$
0.5	$0.72 \cdot 10^{-5}$	$0.36 \cdot 10^{-5}$
1	$0.36 \cdot 10^{-5}$	$0.18 \cdot 10^{-5}$

(84)

All these wave tail durations are greater than the length of a point of the image (2×10^{-7} seconds). The wave tail extends from about 10 points up to 200 points, representing $1/40$ to $1/2$ a line. The longest wave tails occur at low frequencies (long black or white dashes on the image) and in cables with low attenuation β . The duration of the wave tail, it should be repeated, depends solely on the fundamental characteristics of the cable and cannot be modified.

If the wave tail extended only along a length of the order of magnitude of a point or a fraction of a point, the important quantity to be considered would be the integral Q of (79) or any other similar expression. However, a lengthy wave tail tends to spread all the tails of the different signals over a broad band ; they, moreover, present sizeable phase fluctuations. They will therefore appear as a sort of shaded base or, in the terminology of photography, a "cloud." The mean intensities of these tails, but not their amplitudes, have been evaluated.

The intensity of the "cloud" will vary considerably between two extreme limits, i.e., values of $|q|^2$ for 10^6 and 4×10^6 cycles ; $|q|^2$ varies as the power $7/2$ of the frequency, resulting in a margin of variation of intensity

in the ratio of 1 to $4^{7/2} \approx 128$; that is, a variation

in the amplitude of the "cloud" from 1 to $4^{7/4} \approx 11.3$. A "cloud" with a decidedly irregular character, rather than a less objectionable uniform one, is therefore to be expected.

It is obviously essential that this shaded base

be reduced to an inappreciable intensity in order to prevent the appearance of unwanted spots or lines. Its value reaches a maximum at the highest frequency of the television band.

Assume, by way of example, a cable length L of 1 000 km.; the total length should be taken into consideration rather than the length of a section. A suitable level at the outgoing end is maintained by compensating for attenuation by repeated amplification; secondary reflected fluxes, however, add up without interruption. The following therefore applies:

β for $f = 10^6$	0.1	0.2	0.5	1	}	(85)
cycles	Nepers per km.					
βL for $f = 4 \times 10^6$					}	
cycles	Nepers					
$L = 1\ 000$ km.	200	400	1\ 000	2\ 000		

Referring to equation (73), the secondary flux is expressed as a function of $\left(\frac{\Delta Z_r}{Z_o}\right)^2$; that is, by the mean squares of the variations at the input of a long line. These fluctuations must be measured at the maximum band frequency since they depend on the frequency (see 78).

Assuming, therefore, for $|q|^2$ maximum a value 4×10^{-4} (corresponding to 2 per cent. of the amplitude of the principal signal having a frequency of 4×10^6 cycles) for various types of cable characterised by their β at 10^6 cycles, the following values result:

$$\beta \text{ (at } 10^6 \text{ cycles)} = 0.1 \quad 0.2 \quad 0.5 \quad 1$$

$$\left(\frac{\Delta Z_r}{Z_o}\right)^2 = \sqrt{\frac{|q|^2}{\beta L}} = 14 \cdot 10^{-4} \quad 10 \cdot 10^{-4} \quad 6 \cdot 10^{-4} \quad 4.4 \cdot 10^{-4}$$

(86)

where $|q|^2 = 4 \cdot 10^{-4}$ at $4 \cdot 10^6$ cycles.

The order of magnitude of 10^{-2} for $\sqrt{|q|^2}$ corresponds to the indication given by Didlauris and Kaden; the value 2×10^{-2} gives $\left(\frac{\Delta Z_r}{Z_o}\right)^2$ from 4 to 14×10^{-4} , which results in square root values of $\frac{1}{Z_o} \sqrt{\Delta Z^2}$ from 2 to 4×10^{-2} . The American authors (*loc cit.* p. 549) give some

values calculated on the basis of 10^{-2} to 2×10^{-2} without stating whether their cables satisfy them. In any case, the orders of magnitude are very similar.

Admissible irregularities in television images will be discussed later.

It has been shown (equation 52) how cable irregularities result in an augmentation β' of the attenuation, but it is considerably less important than the "cloud" effect. Without much inconvenience, increase of a few per cent.

in β , and accordingly in $\left(\frac{\Delta Z_r}{Z_o}\right)^2$, might be

permissible. The problem of the "cloud" effect caused by the signal tails, however, necessitates that a thousandth part of this quantity be not exceeded (equation 86). This result merits emphasis, since it indicates the great importance of guarding against the occurrence of cable irregularities.

(16) EVALUATION OF ADMISSIBLE IRREGULARITIES IN TELEVISION

In an attempt to define the above indications more precisely, Les Laboratoires, L.M.T. were asked to make several simple optical experiments. P. F. Gloess devised a means of employing a cinematographic apparatus for this purpose. He arranged in the first instance

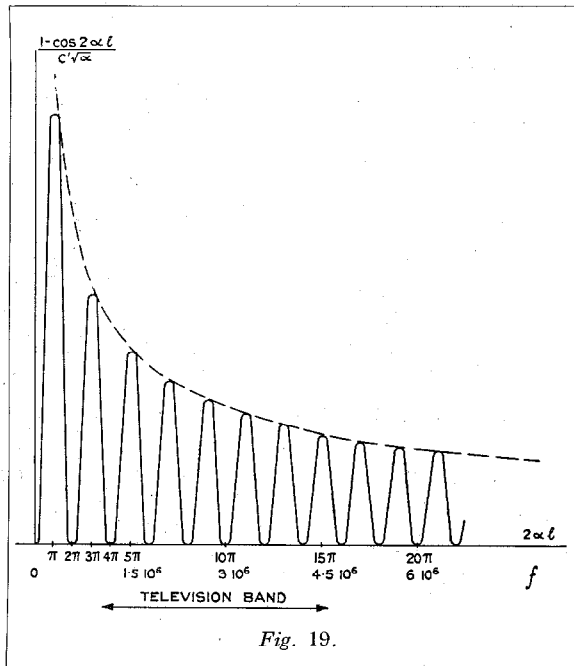

Fig. 19.

to produce a tail in the image corresponding to a length of about a quarter of the screen; he then endeavoured to determine how much the intensity of the light should be reduced in the signal tail in order that the defect would cease to be perceptible to the eye; the relationship limit was found to be of the order 0.03. A slightly higher ratio might have been acceptable in the case of perfect images and the transmission of clear configurations in black and white; in any case, it seems certain that a ratio of 0.02 leaves a wide margin of safety. Since the cathode oscillograph supplies a luminous intensity proportional to the electric current of excitation, the following values have been adopted for calculation involving equation (86): for $\sqrt{|q|^2}$, the ratio 0.03 to 0.02; for $|q|^2$, the value of 10^{-3} to 4×10^{-4} .

In order to produce another sort of defect in the image of the cinematographic apparatus, endeavours were made to superpose a stationary checker design on the cinema image. This stationary image was clearly legible, even at very low intensities; its luminous intensity had to be diminished to about 0.008 to 0.005 of the intensity of the principal image in order to make it imperceptible, thus yielding values for $|q|^2$ of the order of 6×10^{-5} to 2×10^{-5} . Everything considered, it would appear that with electrical signals the following are permissible:

wave train	-30 to -35 db,
regular fault signals	-40 to -50 db.

These values seem to correspond with observations of parasitic effects in television.

(17) LOCAL IRREGULARITIES AND VARIATIONS IN CABLE SECTIONS

Two types of irregularities occurring in a long cable have already been considered (section 5): the first, due to small localised irregularities (s); the others, due to slight differences, S_n , in the mean impedances of different cable sections. Equation (21) represents the comprehensive law of correlation derived. The entire theory applies without modification to a problem of the kind under consideration. When in the final formulæ a term $G = |S|^2 F(2\gamma)$ is found, it suffices to substitute:

$$G = \frac{|s|^2}{S_n^2} F(2\gamma) + \frac{|s|^2}{S_n^2} F_{IV}(2\gamma), \quad (87)$$

where $F(2\gamma)$ represents the integral (29) of the correlation function f , relative to localised irregularities, whilst F_{IV} is the function (31.IV) corresponding to manufacturing sections of length l . Referring to Table I, the substitution of (87) can be made in (34), giving $|p|^2$, which reappears unchanged in equations (40), (52) and (73).

Examining the relative role of the two terms of (87) it is found that, assuming a short distance correlation, the first shows a slow variation—the case discussed in sections 14 and 15. The second term plays a very different part; introduced in equation (34), it supplies a contribution:

$$\begin{aligned} |p|^2 &= \frac{\alpha^2 S_n^2}{4 \beta Z_o^2} F_{IV}(2\gamma) \\ &= \frac{S_n^2}{Z_o^2} \frac{1}{8\beta l} (1 - \cos 2\alpha l). \end{aligned} \quad (88)$$

This expression contains a series of maxima separated by zero, representing a very rapid variation in the useful frequency range. The zero values are obtained for

$$\begin{aligned} 2\alpha l &= 0, 2\pi, 4\pi, \dots, 2K\pi, \dots \\ \alpha &= \frac{2\pi}{W} f_o = \frac{K\pi}{l}; f_o = \frac{KW}{2l}. \end{aligned} \quad (89)$$

Taking a manufacturing length l of 230 metres, and a wave velocity W of 280×10^6 m. per second, it follows that:

$$f_o \approx K6 \times 10^5 \text{ cycles, where } K \text{ is a whole number.} \quad (90)$$

The attenuation β varies as $\sqrt{\alpha}$, at any rate as a first approximation, so that expression (88) may be represented by a curve of the type of Fig. 19. The rapid variations are the cause of irregularities in the corresponding wave tails.

In order to compare the order of magnitude of the effects due to short irregularities or to inequalities in different cable sections, reference is made to equation (87). In short irregularities, the function $F(2\gamma)$ is reduced practically to the distance of correlation $2r$ (equation 33) and, accordingly,

$$F(2\gamma) = 2r \approx 20 \text{ metres.} \quad (91)$$

In the second term, $F_{IV}(2\gamma)$ should be introduced according to (31.IV):

$$F_{IV}(2\gamma) = \frac{1}{2l\alpha^2} (1 - \cos 2\alpha l) \ll \frac{1}{l\alpha^2}$$

$$= \frac{4l}{(2\alpha l)^2} = 10 \text{ to } 0.6 \text{ metre.} \quad (92)$$

The factor $(1 - \cos 2\alpha l)$ yields the curve of Fig. 19. Taking the curve of the maxima and replacing the parenthesis by 2; $2\alpha l$ varies from 3π to 15π ; i.e., from 10 to 45 approximately in the television band (Fig. 19). The value of l is 230 metres, which defines the order of magnitude of (92).

The term $F_{IV}(2\gamma)$ thus constitutes a numerical factor which is clearly less than the factor $F(2\gamma)$ of the first term of (87).

To summarise: the inequalities between cable sections of 230 metre length, within the television band, give rise to very definite differences in the wave tail; these differences, however, are extremely small numerically.

(18) INFLUENCE OF SECTION GROUPING

The computations of sections 5 and 17 were made on the assumption of chance grouping of the different cable sections. In actual practice the sections are grouped (or matched) according to their impedances Z_n . Reflection at the junctions of sections is proportional to $\frac{Z_{n+1} - Z_n}{Z_{n+1} + Z_n}$;

clearly, by diminishing the differences $Z_{n+1} - Z_n$, reflection is minimised.

In order to study the problem a little more closely, let us assume that the sections are grouped so as to follow, as far as possible, a continuous variation law $\Phi(x)$ such as indicated in Fig. 20. This law will be applied as simply as possible, and the calculations separated into three stages:

1. The part played by the local differences along each section—

$$s(x) = Z(x) - \bar{Z}_n;$$

2. The part played by the differences between \bar{Z}_n mean of each section and the mean law Φ selected—

$$S'_n = \bar{Z}_n - \Phi(nl); \quad (93)$$

3. The influence of the mean law Φ .

In the first two stages, the calculations are identical with those of sections 5 and 17, except that S_n of equation (19) is replaced by S'_n of

(93). It is apparent that advantageous grouping makes it possible to greatly decrease S' with relation to S so that, in the final formulæ, $\overline{S_n^2}$ may be replaced by $\overline{S_n'^2}$, which is much smaller.

The part played by the slow continuous variation $\Phi(x)$ along the line still remains to be examined. Let us consider a case involving a *systematic sinusoidal variation*:

$$\Phi(x) = Z_o \left[1 + \frac{2a}{\alpha'} \cdot \sin \alpha' x \right]. \quad (94)$$

For an infinitesimal segment dx , the variation is $d\Phi = 2a Z_o \cdot \cos \alpha' x \cdot dx$;

hence, there occurs a reflecting factor:

$$dr = \frac{d\Phi}{2\Phi} \approx \frac{d\Phi}{2Z_o} = a \cos \alpha' x \, dx. \quad (95)$$

The current reflected towards the entrance of the cable is:

$$p = \int_0^L e^{-2\gamma x} a \cos \alpha' x \, dx = \frac{a}{2} \int_0^L \left\{ e^{(-2\gamma + j\alpha')x} + e^{-2\gamma - j\alpha'x} \right\} dx.$$

If the cable be sufficiently long ($L \gg \frac{1}{2\beta}$):

$$p = \frac{a}{2} \left[\frac{1}{2\gamma - j\alpha'} + \frac{1}{2\gamma + j\alpha'} \right]$$

$$= \frac{a(j\alpha + \beta)}{-2\alpha^2 + 2\beta^2 + \frac{\alpha'^2}{2} + 4j\alpha\beta} \quad (96)$$

The intensity of the reflected wave towards the entrance is obtained by taking the square of the modulus of p :

$$|p|^2 = p \cdot p^*$$

$$= a^2 \frac{\alpha^2 + \beta^2}{\left\{ -2\alpha^2 + 2\beta^2 + \frac{\alpha'^2}{2} \right\}^2 + 16\alpha^2\beta^2} \quad (97)$$

This expression shows a very clear maximum for an adjacent frequency corresponding to:

$$\alpha^2 = \frac{\alpha'^2}{4} \text{ and } \alpha = \frac{\omega}{W} = \frac{\alpha'}{2}, \quad (98)$$

since the denominator then becomes very small (Fig. 21).

This maximum would be somewhat displaced

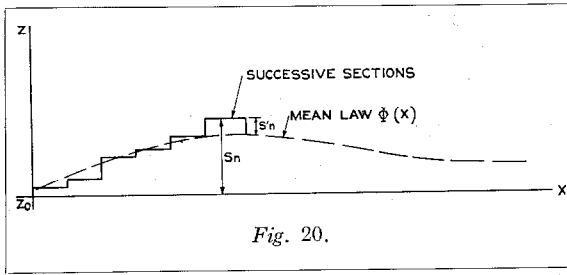

Fig. 20.

from the position of (98) if the attenuation β were not negligible compared with α . The reflected intensity towards the entrance may be represented by an actual curve of resonance around the value given by (98).

This resonance manifests itself clearly only if the term α' be great as compared with β . Consequently, the periodic variation (equation 94) corresponds to several oscillations along a distance of line of the order of $\frac{1}{\beta}$. This effect

is completely avoided by constructing the line in a manner such that the mean impedance variations are produced on lengths of $\frac{1}{\beta}$ or over.

The term $S_n^{1/2}$ thus can be reduced considerably in accordance with equation 93, thereby enormously decreasing the part played by the reflections between successive sections without introducing parasitic resonance of the type described above.

(19) MEASUREMENT OF THE MEAN SQUARES $\left(\frac{\Delta Z_r}{Z_o}\right)^2$ AT THE ENTRANCE OF A LINE

A final problem arises, namely, that of

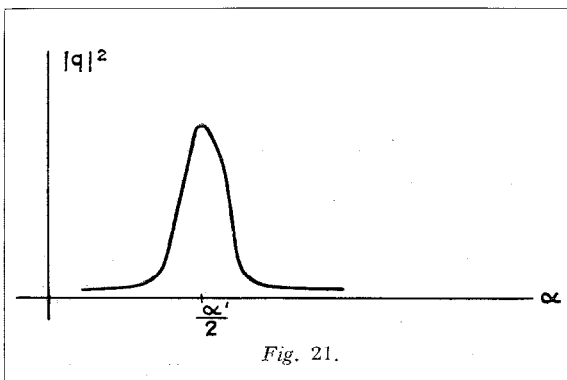

Fig. 21.

determining the meaning to be attributed to averages, such as $\left(\frac{\Delta Z_r}{Z_o}\right)^2$ relative to the variations Z_r of the apparent resistance at the input of a line. In section 7 (equation 40) it was stated that these mean values referred in principle to a group of cables "of the same manufacture" and of lengths L greater than β^{-1} , which might be considered infinite. Only one line actually installed will generally be available for practical measurements. Endeavours should be made to measure the average values of ΔZ_r at different frequencies. Mertz and Pflieger proposed proceeding in this manner (p. 543) and making tests on a moderate range of frequencies.

Let us consider the problem involved in such measurements by taking two waves of frequency ω_1 and ω_2 ; tests made with such waves would not be independent if their frequencies were too close together, since a certain correlation would then exist between them. This correlation would be eliminated if the difference in frequency were sufficiently great, the definite relation being :

$$\Delta \omega \gg \frac{2}{\theta}; \text{ that is, } \Delta \omega \gg 2 \beta W, \quad (99)$$

where the time characteristic θ reappears. It may be explained as follows :

Important reflected waves are produced in a cable section of length β^{-1} ; this section contains a certain number, n , of wavelengths λ for a given frequency :

$$n = \frac{1}{\beta \lambda} = \frac{\omega}{2 \pi \beta W}; \quad \lambda = 2 \pi \frac{W}{\omega}.$$

Correlation obtains whilst n varies only slightly : the results have no further correlation if n varies by several units :

$$\Delta n \gg 1. \quad (100)$$

This condition is equivalent to the preceding (99). It will readily be understood that two waves, ω_1 and ω_2 , the lengths of which differ according to (100), will yield different reflections along a length β^{-1} . More detailed calculation confirms this result.

A wave ω_1 with a propagation constant γ_1 yields a reflected wave at the input characterised

by an amplitude p_1 , given by the formula (26) for an infinite line :

$$p_1 = \frac{\gamma_1}{Z_0} \int_0^\infty e^{-2\gamma_1 x} S(x) dx ;$$

$$\gamma = j\alpha + \beta . \quad (101)$$

For a wave ω_2 , γ_2 and p_2 likewise apply. In order to study the correlation between these two reflected waves, the expression $\overline{p_1 p_2^*}$ may be transformed similar to equation (28) :

$$R(\omega_1, \omega_2) = \overline{p_1 p_2^*}$$

$$= \frac{\gamma_1 \gamma_2^*}{Z_0^2} \overline{|S|^2} \int_0^\infty e^{-2(\gamma_1 + \gamma_2^*)x} dx$$

$$\int_0^\infty f(x-x') e^{+2\gamma_2^*(x-x')} dx'$$

$$= \frac{\gamma_1 \gamma_2^* \overline{|S|^2}}{Z_0^2} \cdot \frac{F(2\gamma_2)}{2(\gamma_1 + \gamma_2^*)} \quad (102)$$

This equation is analogous to (34). Assuming that the frequency interval is not very high, and writing :

$$\omega_1 = \omega_2 + \Delta\omega ; \quad \gamma_1 = \gamma_2 + \frac{\partial\gamma}{\partial\omega} \Delta\omega ;$$

equation (34) being taken as a factor, i.e., $\overline{|p_2|^2}$, it follows that :

$$R(\omega_1, \omega_2) = \overline{|p_2|^2} \frac{4\beta_2}{|\gamma_2|^2} \cdot \frac{\gamma_1 \gamma_2^*}{2(\gamma_1 + \gamma_2^*)}$$

$$= |p_2|^2 \frac{1 + \frac{\Delta\omega}{\gamma} \frac{\partial\gamma}{\partial\omega}}{1 + \frac{\Delta\omega}{2\beta_2} \frac{\partial\gamma}{\partial\omega}} , \quad (103)$$

since $2(\gamma_1 + \gamma_2^*) = 4\beta_2 + 2 \frac{\partial\gamma}{\partial\omega} \Delta\omega$.

Inasmuch as α is much greater than the attenuation β :

$$\frac{\partial\gamma}{\partial\omega} \approx j \frac{\partial\alpha}{\partial\omega} = \frac{j}{W}$$

where W = velocity of phase.

In the fraction R , the numerator reduces to $1 + \frac{\Delta\omega}{\omega}$, differing very slightly from unity ; the denominator plays the essential part ; therefore,

$$R(\omega_1, \omega_2) \approx \overline{|p_2|^2} \frac{1}{1 + \frac{j}{2} \theta \Delta\omega} , \quad (104)$$

with $\theta = \frac{1}{\beta W}$.

This equation justifies all the statements made above. The correlation between the reflected waves towards the input disappears when the difference $\Delta\omega$ of the pulsations is great compared with $2\theta^{-1}$; it represents a special case of equation (99).

Correlation occurs if the difference $\Delta\omega$ be very small.

Erratum

Electrical Communication, "Electrical Properties of Aerials for Medium and Long Wave Broadcasting" :

April, 1938, page 317,

Equation (30) should read as follows :

$$R = 60 \int_0^{\frac{\pi}{2}} K_\theta^2 \sin \theta \cdot 2 \left\{ 1 + \cos \beta \cdot \mathcal{F}_0 \left(\frac{2\pi l}{\lambda} \times \sin \theta \right) \right\} d\theta ;$$

July, 1938, page 47, last paragraph,

K_θ and K_θ' should be interchanged.

Notes on the Effects of Irregularities in Coaxial Cables on Television Transmission*

By J. SAPHORES,

Professor at the Ecole de Physique et de Chimie Industrielles de Paris,

and

P. GLOESS,

Les Laboratoires, Le Matériel Téléphonique, Paris, France

1. RÉSUMÉ OF THEORETIC STUDIES

PROBLEMS involved in long distance transmission of television signals have prompted certain physicists to investigate theoretically the effects of characteristic impedance irregularities in coaxial cables. Work in this field has been done mainly by Mertz and Pflieger,¹ Didlaukis and Kaden,² and Léon Brillouin.³ The present article gives first a brief résumé of the conclusions of Brillouin's investigations, which generalize those of Didlaukis and Kaden.

Brillouin assumes that, at the sending end of a long cable terminated with its characteristic impedance ($L \gg \frac{1}{\beta}$, where β is the linear attenuation in nepers), a simple periodic signal is permanently established. This signal is suppressed at a certain instant and disappears at the receiving end at the time $t = 0$.

Because of double reflections due to irregularities in the characteristic impedance, secondary signals continue to arrive at the output end subsequent to the disappearance of the principal signal. Statistical theory permits of the determination of their mean quadratic amplitude

$\sqrt{|q(\gamma, t, \infty)|^2}$ as a function of time, and shows

*Attachment No. 1 to the reply of the French P.T.T. to question No. 1 ter (Meeting of the C.C.I.F. at Oslo, June, 1938).

Symbols used herein are the same as in Prof. Brillouin's article immediately preceding.

¹Mertz and Pflieger: Bell System Technical Journal, 1937, xvi, (541-559).

²Didlaukis and Kaden: E.N.T. 1937, xiv, (13-22).

³Léon Brillouin. (See immediately preceding article in this issue).

that it may take the form :

$$\sqrt{|q(\gamma, t, \infty)|^2} = A \sqrt{|q(\gamma, 0, \infty)|^2} e^{-\frac{t}{\theta}},$$

A being the amplitude of the permanent interrupted signal. This law of decay is valid only after a definite period which, moreover, is short in practice compared with the time constant θ (see Fig. 1).

Time Constant

The time constant θ is given by $\theta = \frac{1}{\beta w}$,

where

β = attenuation in nepers per unit of length, and

w = speed of propagation along the cable (assumed to be 280 000 km/s).

Adopting, in the case of a cable with diameters in the ratio of 3.6 and with two copper conductors, the simplified relationship (dielectric losses being ignored):

$$\beta_{\text{Népl/km}} = \frac{0.25}{D_{\text{cm}}} \sqrt{F_{\text{Mc/s}}}, \text{ where } D = \text{diameter}$$

of return conductor; it is found, for example, that if $D = 1$ cm,

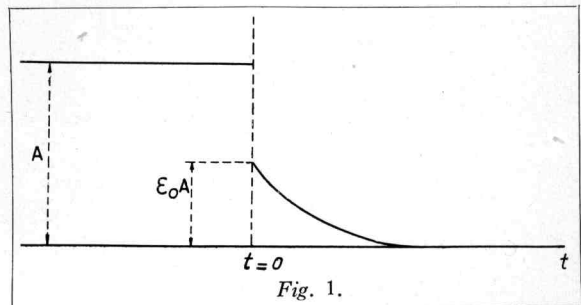

$$F' = 1 \text{ Mc/s, } \theta = \frac{1}{70\,000} \text{ sec, and}$$

$$F = 4 \text{ Mc/s, } \theta = \frac{1}{140\,000} \text{ sec.}$$

In the case of 25 images per second and 400 lines per image, these two values correspond, respectively, to 1/7 line and 1/14 line.

In transmissions utilising this frequency band, it is evident that the duration of the signal trains will be variable at different frequencies. Their effect will extend over 1/10 of a line minimum.

Mean initial intensity

By simple transformations $\sqrt{|q|^2}$, which represents the relative initial mean amplitude of the secondary signals, may be derived, in the form :

$$\sqrt{|q|^2} = 4 \pi^2 \frac{\sqrt{L} l_a \cdot r}{\lambda^2} \frac{|s|^2}{Z_o^2} \dots\dots\dots(1)$$

where L = length of cable,

$l_a = \frac{1}{\beta}$, β being the linear attenuation in nepers,

λ = wavelength in the cable of the transmitted wave,

r = correlation distance ; it is the distance, inaccurately determined, beyond which two local cable irregularities may be considered independent,

(For a particular cable studied by them, Didlaukis and Kaden have given the value $r = 3$ metres. It would seem that the value of r is usually of the order of a few metres.)

Z_o = mean characteristic impedance of the cable,

$\sqrt{|S|^2}$ = mean quadratic value along the cable of the local characteristic impedance fluctuations around Z_o ,

Equation (1), nevertheless, is merely a first approximation which assumes the wavelength to be far greater than the distance of correlation. It is, moreover, established only for certain particular laws of correlation studied by Brillouin.

The equation shows that the relative initial amplitude $\sqrt{|q|^2}$, like the time constant θ ,

varies with frequency (through the intermediary of l_a and λ).

In so far as television images are concerned, it would seem to follow that : "The drawing out of the signal spreads the tails of the signals over a wide band. These tails, moreover, display important phase fluctuations ; their mean intensities have been computed, but not their amplitudes. They take the form of a grey background ; in photographic terminology, a sort of 'veiling' of the images."³

2. EXPERIMENTAL DETERMINATION

The object of the following experiments was to produce, in the systematically projected images, a "drawing out" effect comparable to a degree to the phenomena mentioned above, and to determine approximately the level below which the "veiling" of the images ceases to exercise an adverse effect on the eye.

It should be emphasized that highly accurate measurements are not required since visual reaction is dependent on a large number of factors and, in particular, on the luminous intensity of the images examined. The experimental set-up comprised ordinary cinematograph projection apparatus, involving merely modification of the shutter and fitting of the lens with a special diaphragm.

Basically, the ordinary cinema shutter consists of a disc containing two blades P_1 and P_2 , as illustrated in Fig. 2. This disc rotates with uniform motion. The blade P_1 screens the

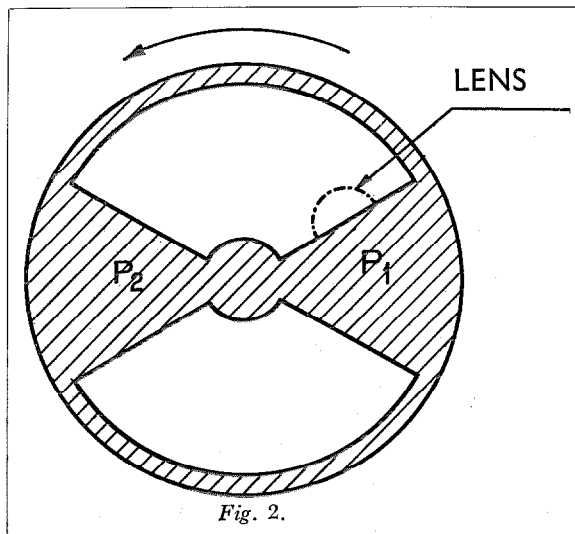

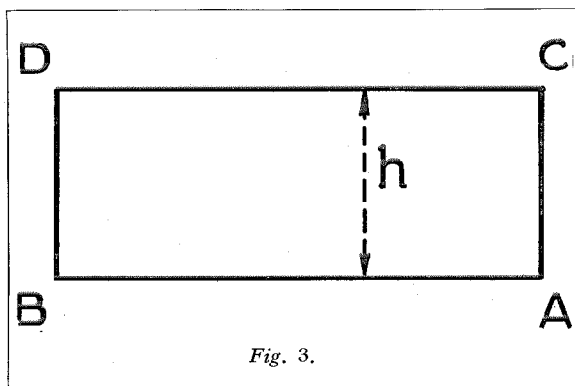

Fig. 3.

object during the time when the film is in movement in order to permit passing from the projection of one image to that of the following. The blade P_2 screens the lens for a short period when the film is at rest, its only object being reduction of the flicker effect to which the eye is sensitive when images are unfolded without special precautions at normal speed (25 per second).

If holes be pierced in the blade P_1 , the film will be revealed in the course of its movement; and, on the fixed projection, a moving image will be superposed on the screen, the extent and illumination of which, in the direction of motion, will depend upon the sizes of the apertures.

This parasitic image plays the same part with respect to the projected image as the above-mentioned signal tails in television. The device actually adopted is shown diagrammatically in Fig. 3.

The lens is fitted with a diaphragm in the form of an elongated rectangle, the length of which is Δ in the direction of the radius. The opening arranged in the blade P_1 has the form of a circular channel of radial magnitude ϵ subtending an angle α_2 at the centre. The total angle at the centre, corresponding to the two periods during which the lens is uncovered and the film motionless, is α_1 .

The ratio of the energies transmitted through the film, whilst in movement and whilst fixed, in the course of a revolution is accordingly :

$$\frac{W_2}{W_1} = \frac{\alpha_2}{\alpha_1} \frac{\epsilon}{\Delta} = n.$$

This ratio, n , can easily be modified by changing the angles α_1 and α_2 , or Δ and ϵ .

Let us now consider the appearance of the screen projection, formed by a succession of simple and identical images. The choice, for example, may be made of a test image consisting of a transparent rectangle on an opaque background. If the blade P_1 contains no opening, a simple luminous rectangle on a black background will be seen on the screen (Fig. 4).

The aperture arranged in the blade P_1 , whilst uncovering the film during part of its movement, superposes on the preceding image an attenuated image of the rectangle in movement; that is, the screen will show, following the luminous rectangle, a grey shadow (Fig. 5), the length of which is dependent on the angle α_2 , as well as on the laws of variation of brilliancy and of the film movement, neither of which are known.

Experience indicates that the law of decrease in brilliancy, B , of a signal train for the part exterior to the principal rectangle, may be considered exponential and takes the form :

$B = B_0 e^{-\frac{x-h}{L}}$. B_0 is the brilliancy of the signal tail immediately adjacent to the straight line CD ; x , the distance of a current point of this tail from the side AB ; h , the height of the image; and L , an attenuation constant which can be determined experimentally.

In the principal image the effects of the signal lag are not noticeable; if it be admitted that, from A to C , the brilliancy of the secondary

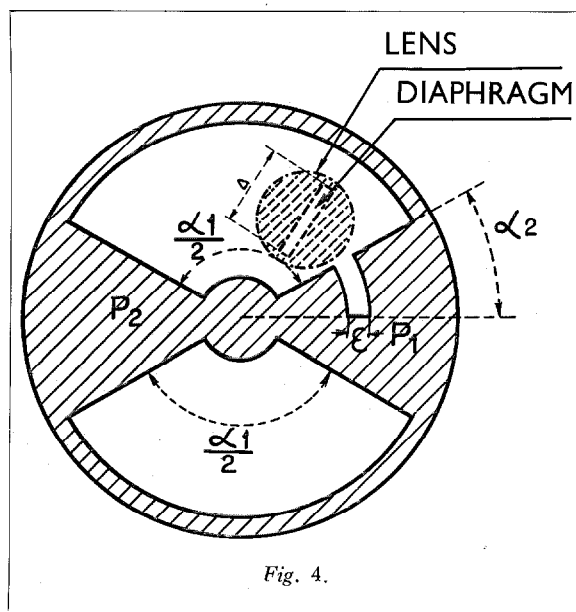

Fig. 4.

signals, due to the lag phenomena, increases exponentially with the same constant L , it is then possible to calculate the ratio of the energies contained in the signal train, and in the principal rectangular image. This ratio may then be written :

$$\frac{W_2}{W_1} = \frac{B_o}{B_1} \cdot \frac{1}{1 - e^{-\frac{h}{L}}}$$

where B_o is the brilliancy of the signal train in the vicinity of $C D$, and B_1 the brilliancy of the rectangular fixed image. The value of this ratio, however, has already been derived, viz.,

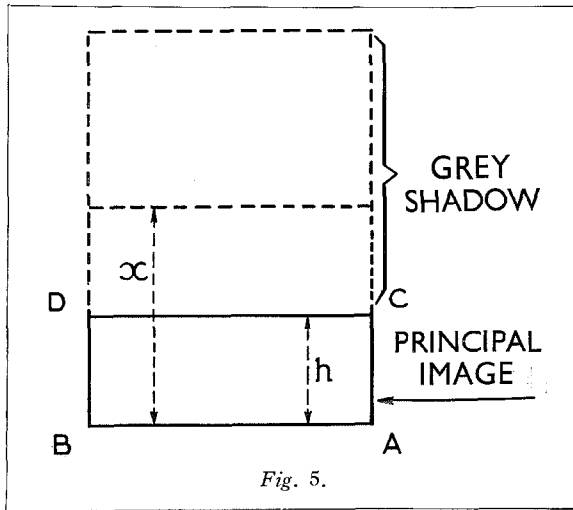

Fig. 5.

$$n = \frac{\alpha_2}{\alpha_1} \frac{\epsilon}{\Delta}$$

If the value to be assigned to n in order to obviate an objectionable signal train be experimentally determined, the admissible value can be deduced for the ratio $\frac{B_o}{B_1}$ of the brilliancy of the initial signal train and the principal image. Experiments made under these conditions show that the admissible limit for $\frac{B_o}{B_1}$ is of the order of $\frac{1}{30}$.

If instead of the foregoing test film an ordinary commercial film be projected, it will be found that spectators, who have not been forewarned, will be completely unaware of the interference in the projection as a result of the extension of the signals produced by the shutter

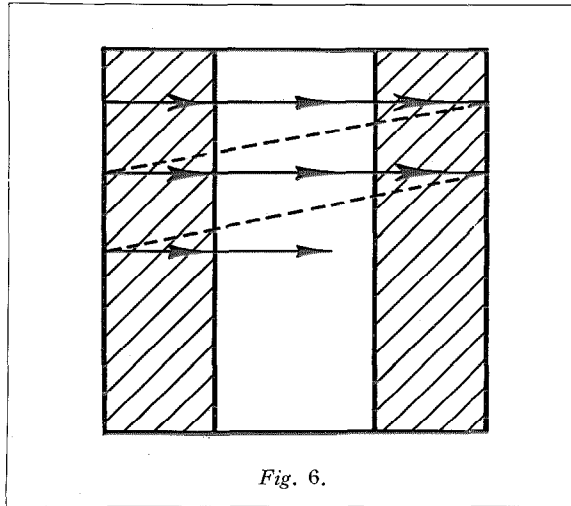

Fig. 6.

which has been modified to obtain the ratio $\frac{B_o}{B_1} = \frac{1}{30}$.

3. APPLICATIONS TO TRANSMISSIONS ON CABLES

Equation (1), in view of the hypothesis that the coaxial conductor radii are in the ratio 3.6, also the adoption for the attenuation constant of a simplified expression which ignores the losses in the dielectric, as well as the assumption of a propagation speed of approximately 280 000 km/s., may readily be written in the following form :

$$\frac{\sqrt{|S|^2}}{Z_o} = \sqrt[4]{|q|^2} \sqrt[4]{L_{km}} \sqrt[4]{D_{cm}} \sqrt{r^m} F^{\frac{1}{2}} \text{ Megacycles.}$$

If one accepts for $\sqrt{|q|^2}$ the value $\frac{1}{30}$ resulting from the foregoing experiments, and adopts the values $L = 1\ 000$ km, $D = 1$ cm, $r = 3$ m,

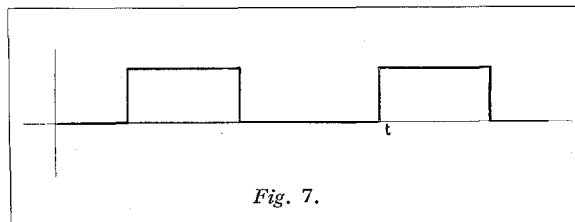

Fig. 7.

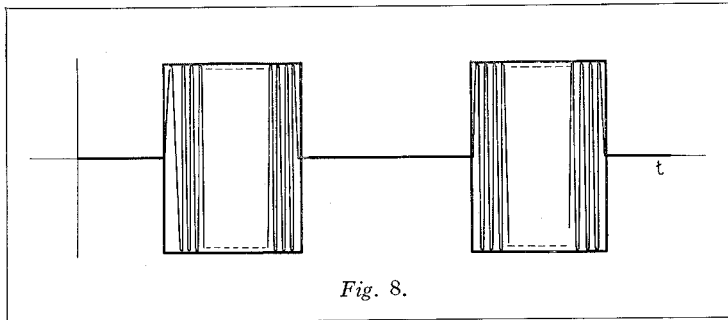

Fig. 8.

$F = 4$ Mc/s, it is found that, if $Z_o = 72$ ohms, the mean quadratic value of the elementary characteristic impedance fluctuations is :

$$\sqrt{|S|^2} = 0.4 \text{ ohm.}$$

Assuming, further, that this value results solely from changes in the diameter of the return conductor, the mean quadratic value of these changes may easily be calculated; it equals 0.07 mm.

4. RELATION BETWEEN THEORY AND ACTUAL TRANSMISSION POSSIBILITIES OF CORRECTION

Exact applications of theory to actual transmission problems are fairly difficult. The theory deals primarily with a simple periodic signal established for some time; that is, appreciably greater than $\theta = \frac{1}{\beta w}$, the wave train time constant. At any moment following the interruption of the principal signal, the statistical theory merely gives information as to the probable value of the amplitude of the secondary signal resulting from the double reflections. The simplest actual case which appears to satisfy the assumed conditions would be the following :

Assume that an analysis is required of a fixed image consisting of a fairly large transparent vertical band on a black background (Fig. 6).

This analysis would involve rectangular signals (Fig. 7) suitable for modulation of the amplitude of a high frequency wave. Assume the amplitude at a maximum for the white portions of the image and zero for the black portions; also, that trans-

mission along the cable is to take place without other modification. Series of successive waves in rectangular envelopes would then be transmitted through the cable (Fig. 8).

If the size of the transparent band is about a half-line, the theoretical conditions will be practically realised inasmuch as the wave trains extend over

approximately 1/10 line. A lag effect will occur at the output of the cable when each series of waves is established and suppressed. The envelopes of the wave series, on the assumption that the real amplitudes of the secondary signals do not differ greatly from the probable theoretical value, will be as shown in Fig. 9.

The modulation envelope, consequently, is periodic and can be expressed as a Fourier series with a fundamental frequency the same as that of the line at both the input and the output end of the cable (Figs. 8 and 9, respectively). Cable irregularities, therefore, may be regarded as equivalent to the introduction of supplementary distortions of amplitude and phase as functions of frequency. Such distortions, at least within certain limits, may obviously be corrected.

In a cable free from irregularities, the attenuation is a function of the frequency and can be neutralized by the introduction of a suitable equalizer. If, moreover, the cable or other units of the transmission system introduce delays in transmission varying with frequency, the resultant distortions may be eliminated by means of a phase compensator.

Assume, further, that the same cable contains a large number of small irregularities. When a simple periodic signal is applied to the input,

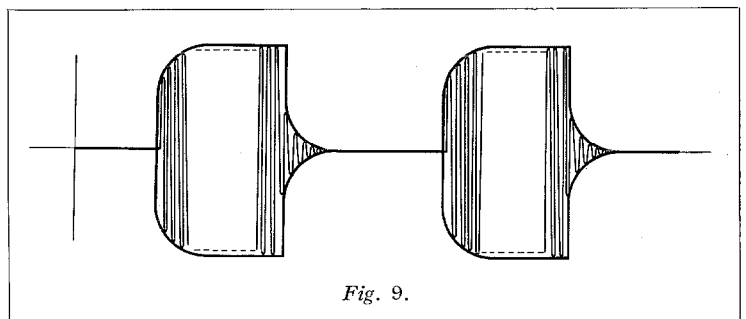

Fig. 9.

the signal received at the output end, as regards amplitude and phase, differs from that which a cable free from irregularities would have transmitted. These two deviations are, therefore, functions of frequency.

Hence, the occurrence of irregularities results in a change of the law of variation of attenuation as a function of frequency, and also in the law of variation in transmission retardation. It follows that, for a given cable, there are applicable two perfectly defined and independent laws relating to the composition of complex signals which may be transmitted. Corrections of the same type as in the case of a cable free from irregularities are accordingly possible in principle. It is, nevertheless, obvious that the correction of transmission deviations occasioned by irregularities is not a simple matter when complex conditions are introduced through variations, as a function of frequency, in attenuation and dephasing. An additional

difficulty, moreover, results from the minuteness of the secondary corrections relative to the primary values.

Stated differently, possible corrective measures are subject to retention of the disturbing effects corresponding to variations in accordance with the simple laws of probability from which the statistical theories are deduced.

The only information available on the importance of these variations is contained in the article by Mertz and Pflieger. It tends to show that they are not negligible.

Consideration must also be given to irregularities of other types, such as those which may exist at cable joints.

Whilst definite corrective measures for cable irregularities are undoubtedly possible, they can be applied only to certain of the disturbing elements. Limits to be assigned to cable irregularities, therefore, must be chosen with due regard to the problem as a whole.

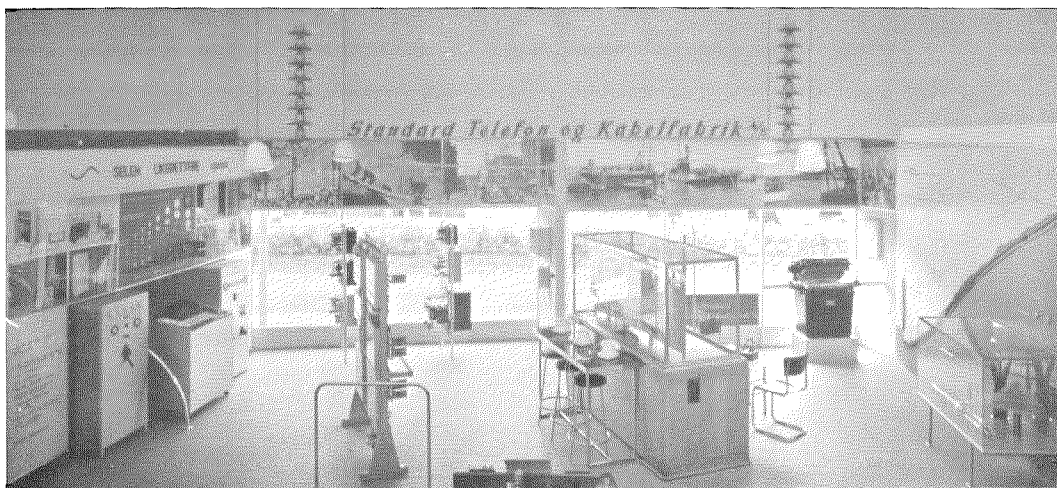

THE STANDARD TELEFON OG KABELFABRIK A/S AT THE OSLO EXHIBITION, 1938

The stand included a model of the 7.A2 Rotary System equipped with Automatic Ticketing facilities enabling a call to be made from the exhibition to any Oslo subscriber and producing a ticket giving complete data of the connection.

1937 Paris Exhibition Awards

AN article in the October 1937 issue of this journal described the important and successful part taken in the 1937 Paris Exhibition by Le Matériel Téléphonique. In view of this participation, the following awards have been made to L.M.T., its Manager, and some members of its staff.

CLASS 8-D: SECURITY

<i>Member of Jury</i>	Mr. J. Roussel, Manager, "Le Matériel Téléphonique."
<i>Diplômes d'honneur</i>	Messrs. R. Lucas and E. Madelin, Engineers, "Le Matériel Téléphonique."
<i>Médailles d'or</i>	Messrs. V. Poret and E. Soleil, Engineers, "Le Matériel Téléphonique."
<i>Médailles d'argent</i>	Mr. A. Pluchon, Installation Agent, "Le Matériel Téléphonique."

CLASS 15 bis: RADIOCOMMUNICATIONS, RADIOTELEPHONY AND TELEVISION

<i>Member of Jury</i>	Mr. J. Roussel, Manager, "Le Matériel Téléphonique."
<i>Diplômes d'honneur</i>	Mr. H. Busignies, Engineer, "Le Matériel Téléphonique."
<i>Médailles d'or</i>	Messrs. P. Garès, G. Meunier, Engineers, and M. Porri, Installation Agent, "Le Matériel Téléphonique."

CLASS 66-A: SHIPPING TRANSPORT

<i>Médailles d'argent</i>	"Le Matériel Téléphonique."
-------------------------------------	-----------------------------

CLASSES 67-A and B: CIVIL AND MILITARY AERONAUTICS

<i>Grand Prix</i>	"Le Matériel Téléphonique."
<i>Diplômes d'honneur</i>	Messrs. H. Busignies, J. Lair and G. M. Perroux, Engineers, "Le Matériel Téléphonique."
<i>Médailles d'or</i>	Mr. P. Giroud, Engineer, "Le Matériel Téléphonique."
<i>Médailles d'argent</i>	Messrs. E. Méhut and G. Seibel, Engineers, "Le Matériel Téléphonique."

Telephone and Telegraph Statistics of the World

Compiled by Chief Statistician's Division, American Telephone and Telegraph Company

Telephone Development of the World, by Countries January 1, 1937

COUNTRIES	NUMBER OF TELEPHONES			Per Cent. of Total World	Telephones Per 100 Population
	Government Systems	Private Companies	Total		
NORTH AMERICA :					
United States	—	18,433,400	18,433,400	49.69%	14.39
Canada	194,624	1,071,604	1,266,228	3.41%	11.48
Central America	12,741	14,295	27,036	0.07%	0.38
Mexico	1,337	123,442	124,779	0.34%	0.66
West Indies :					
Cuba	610	43,972	44,582	0.12%	1.02
Puerto Rico	531	14,272	14,803	0.04%	0.84
Other W. I. Places	7,711	15,969	23,680	0.06%	0.34
Other No. Am. Places	—	17,915	17,915	0.05%	5.03
Total	217,554	19,734,869	19,952,423	53.78%	11.14
SOUTH AMERICA :					
Argentina	—	348,184	348,184	0.94%	2.77
Bolivia	—	2,450	2,450	0.007%	0.08
Brazil	1,924	220,588	221,982	0.60%	0.45
Chile	—	63,055	63,055	0.17%	1.38
Colombia	8,400	33,000	41,400	0.11%	0.42
Ecuador	3,750	3,000	6,750	0.02%	0.27
Paraguay	—	2,843	2,843	0.008%	0.32
Peru	—	23,883	23,883	0.06%	0.36
Uruguay	21,000	13,500	34,500	0.09%	1.68
Venezuela	648	16,740	17,388	0.05%	0.51
Other So. Am. Places	3,000	—	3,000	0.008%	0.55
Total	38,722	726,713	765,435	2.06%	0.80
EUROPE :					
Austria	279,595	—	279,595	0.76%	4.10
Belgium†	361,685	—	361,685	0.98%	4.34
Bulgaria	22,713	—	22,713	0.06%	0.36
Czechoslovakia	207,287	—	207,287	0.56%	1.36
Denmark†	17,323	391,552	408,875	1.10%	10.89
Finland	4,740	155,729	160,469	0.43%	4.20
France	1,481,788	—	1,481,788	4.00%	3.51
Germany†	3,431,074	—	3,431,074	9.25%	5.08
Great Britain and No. Ireland	2,791,597	—	2,791,597	7.53%	5.93
Greece	8,083	30,092	38,175	0.10%	0.55
Hungary	136,902	749	137,651	0.37%	1.53
Irish Free State†	38,376	—	38,376	0.10%	1.30
Italy	—	560,660	560,660	1.51%	1.31
Jugo-Slavia	55,314	—	55,314	0.15%	0.36
Latvia†	71,769	—	71,769	0.19%	3.64
Lithuania	19,588	—	19,588	0.05%	0.78
Netherlands	382,173	—	382,173	1.03%	4.47
Norway**	127,212	83,396	210,608	0.57%	7.26
Poland	133,782	111,142	244,924	0.66%	0.71
Portugal	15,988	44,405	60,393	0.16%	0.83
Roumania	—	70,678	70,678	0.19%	0.36
Russia†	950,000	—	950,000	2.56%	0.55
Spain*	—	341,390	341,390	0.92%	1.38
Sweden	686,076	1,490	687,566	1.85%	10.97
Switzerland	412,324	—	412,324	1.12%	9.86
Other Places in Europe	86,480	—	86,480	0.23%	1.62
Total	11,721,869	1,791,283	13,513,152	36.43%	2.35
ASIA :					
British India†	29,003	45,053	74,056	0.20%	0.02
China	85,000	92,000	177,000	0.48%	0.04
Japan†	1,197,129	—	1,197,129	3.23%	1.70
Other Places in Asia	151,925	90,868	242,793	0.65%	0.14
Total	1,463,057	227,921	1,690,978	4.56%	0.16
AFRICA :					
Egypt	56,579	—	56,579	0.15%	0.26
Union of South Africa†	169,419	—	169,419	0.46%	1.75
Other Places in Africa	107,186	2,032	109,218	0.29%	0.09
Total	333,184	2,032	335,216	0.90%	0.22
OCEANIA :					
Australia**	562,868	—	562,868	1.52%	8.31
Hawaii	—	27,581	27,581	0.08%	6.95
Netherlands East Indies	38,098	3,831	41,929	0.11%	0.06
New Zealand†	178,599	—	178,599	0.48%	11.25
Philippine Islands	1,256	24,195	25,451	0.07%	0.18
Other Places in Oceania	4,124	328	4,452	0.01%	0.19
Total	784,945	55,935	840,880	2.27%	0.89
TOTAL WORLD	14,559,331	22,538,753	37,098,084	100.00%	1.71

* January 1, 1936.

** June 30, 1936.

† February 28, 1937.

‡ March 31, 1937.

† U.S.S.R., including Siberia and Associated Republics. (Estimated.)

‡ Includes approximately 18,300,000 automatic or "Dial" telephones, of which about 43% are in the United States.

Telephone and Telegraph Wire of the World, by Countries January 1, 1937

COUNTRIES	Service Operated By (See Note)	MILES OF TELEPHONE WIRE			MILES OF TELEGRAPH WIRE		
		Number of Miles	Per Cent. of Total World	Per 100 Population	Number of Miles	Per Cent. of Total World	Per 100 Population
NORTH AMERICA :							
United States.....	P.	88,100,000	54.12%	68.77	2,285,000	33.55%	1.78
Canada.....	P.G.	5,197,000	3.19%	47.13	357,000	5.24%	3.24
Central America.....	P.G.	61,000	0.04%	0.84	21,000	0.31%	0.29
Mexico.....	P.	751,000	0.46%	3.94	100,000	1.47%	0.52
West Indies :							
Cuba.....	P.	274,000	0.17%	6.30	12,000	0.18%	0.28
Puerto Rico.....	P.	35,000	0.02%	1.99	2,000	0.03%	0.11
Other W. I. Places.....	P.G.	108,000	0.07%	1.53	9,000	0.13%	0.13
Other No. Am. Places.....	P.	22,000	0.01%	6.16	11,000	0.16%	3.08
Total.....		94,548,000	58.08%	52.81	2,797,000	41.07%	1.56
SOUTH AMERICA :							
Argentina.....	P.	1,370,000	0.84%	10.91	140,000	2.06%	1.11
Bolivia.....	P.	5,500	0.003%	0.17	5,000	0.07%	0.16
Brazil.....	P.	885,000	0.54%	1.79	110,000	1.62%	0.22
Chile.....	P.	242,000	0.15%	5.32	50,000	0.73%	1.10
Colombia.....	P.G.	150,000	0.09%	1.53	21,000	0.31%	0.21
Ecuador.....	P.G.	9,000	0.01%	0.36	4,000	0.06%	0.16
Paraguay.....	P.	7,500	0.01%	0.83	3,000	0.04%	0.33
Peru.....	P.	82,000	0.05%	1.23	13,000	0.19%	0.19
Uruguay.....	P.G.	115,000	0.07%	5.60	8,000	0.12%	0.39
Venezuela.....	P.	100,000	0.06%	2.94	7,000	0.10%	0.21
Other So. Am. Places.....	G.	6,000	0.004%	1.09	500	0.01%	0.09
Total.....		2,972,000	1.83%	3.11	361,500	5.31%	0.38
EUROPE :							
Austria.....	G.	673,000	0.41%	9.88	49,000	0.72%	0.72
Belgium†.....	G.	1,918,000	1.18%	23.01	35,000	0.52%	0.42
Bulgaria.....	G.	75,000	0.05%	1.20	5,500	0.08%	0.09
Czechoslovakia.....	G.	651,000	0.40%	4.26	84,000	1.23%	0.55
Denmark†.....	P.	1,353,000	0.83%	36.02	7,500	0.11%	0.20
Finland.....	P.	272,000	0.17%	7.14	21,000	0.31%	0.55
France.....	G.	5,603,000	3.44%	13.37	319,000	4.68%	0.76
Germany†.....	G.	16,470,000	10.12%	24.38	166,000	2.43%	0.25
Great Britain and No. Ireland†.....	G.	13,150,000	8.08%	27.95	255,000	3.74%	0.54
Greece.....	P.G.	124,000	0.08%	1.79	36,000	0.53%	0.52
Hungary.....	G.	422,000	0.26%	4.70	46,000	0.67%	0.51
Irish Free State†.....	G.	130,000	0.08%	4.42	22,000	0.32%	0.75
Italy.....	P.	1,660,000	1.02%	3.89	272,000	3.99%	0.64
Jugo-Slavia.....	G.	145,000	0.09%	0.96	58,000	0.82%	0.37
Latvia†.....	G.	295,000	0.18%	14.97	4,500	0.07%	0.23
Lithuania.....	G.	75,000	0.04%	2.97	2,500	0.04%	0.10
Netherlands.....	G.	1,220,000	0.75%	14.26	12,000	0.18%	0.14
Norway**.....	P.G.	655,000	0.40%	22.59	23,000	0.34%	0.79
Poland.....	P.G.	907,000	0.56%	2.63	49,000	0.72%	0.14
Portugal.....	P.G.	155,000	0.09%	2.13	15,000	0.22%	0.21
Roumania.....	P.	273,000	0.17%	1.39	47,000	0.69%	0.24
Russia†.....	G.	1,500,000	0.92%	0.84	600,000	8.81%	0.33
Spain*.....	P.	1,770,000	1.09%	7.15	90,000	1.32%	0.36
Sweden.....	G.	2,580,000	1.58%	41.17	19,000	0.28%	0.30
Switzerland.....	G.	1,470,000	0.90%	35.32	12,000	0.18%	0.29
Other Places in Europe.....	G.	289,000	0.18%	5.42	14,000	0.21%	0.26
Total.....		53,835,000	33.07%	9.36	2,262,000	33.21%	0.39
ASIA :							
British India†.....	P.G.	565,000	0.34%	0.15	451,000	6.62%	0.12
China.....	P.G.	700,000	0.43%	0.15	140,000	2.06%	0.03
Japan†.....	G.	4,391,000	2.70%	6.25	230,000	3.38%	0.33
Other Places in Asia.....	P.G.	793,000	0.49%	0.47	189,000	2.77%	0.11
Total.....		6,449,000	3.96%	0.60	1,010,000	14.83%	0.09
AFRICA :							
Egypt.....	G.	340,000	0.21%	1.56	35,000	0.51%	0.16
Union of South Africa†.....	G.	677,000	0.42%	6.98	31,000	0.46%	0.32
Other Places in Africa.....	G.	333,000	0.20%	0.28	144,000	2.11%	0.12
Total.....		1,350,000	0.83%	0.89	210,000	3.08%	0.14
OCEANIA :							
Australia**.....	G.	2,600,000	1.60%	38.38	104,000	1.53%	1.54
Hawaii.....	P.	96,000	0.06%	24.18	0	0.00%	0.00
Netherlands East Indies.....	G.	245,000	0.15%	0.36	20,000	0.29%	0.03
New Zealand†.....	G.	600,000	0.37%	37.81	32,000	0.47%	2.02
Philippine Islands.....	P.	72,000	0.04%	0.51	10,000	0.15%	0.07
Other Places in Oceania.....	G.	12,000	0.01%	0.17	4,000	0.06%	0.17
Total.....		3,625,000	2.23%	3.84	170,000	2.50%	0.18
TOTAL WORLD.....		162,779,000	100.00%	7.48	6,810,500	100.00%	0.31

NOTE: Telegraph service is operated by Governments, except in the United States and Canada. In connection with telephone wire, † indicates that the telephone service is wholly or predominantly operated by private companies, G. wholly or predominantly by the Government and P.G. by both private companies and the Government. See preceding table.

* January 1, 1936. ** June 30, 1936. † February 28, 1937. † March 31, 1937.

‡ U.S.S.R., including Siberia and Associated Republics. (Estimated.)

Telephone Development of Large and Small Communities—January 1, 1937

COUNTRY	Service Operated By (See Note)	NUMBER OF TELEPHONES		TELEPHONES PER 100 POPULATION	
		In Communities of 50,000 Population and Over	In Communities of less than 50,000 Population	In Communities of 50,000 Population and Over	In Communities of less than 50,000 Population
Australia**	G.	341,200	221,668	10.41	6.34
Austria	G.	216,982	62,613	9.85	1.36
Belgium†	G.	254,977	106,708	7.15	2.24
Canada	P.G.	689,594	576,634	19.35	7.73
Czechoslovakia	G.	106,263	101,024	5.99	0.75
Denmark	P.	216,663	192,212	20.08	7.18
Finland	P.	60,007	100,462	12.00	3.03
France	G.	818,517	663,271	7.72	2.12
Germany†	G.	2,232,749	1,198,325	7.84	3.07
Great Britain and No. Ireland†	G.	2,062,000	798,000	7.65	3.97
Hungary	G.	104,007	33,644	4.92	0.49
Japan†	G.	805,735	391,394	3.64	0.81
Netherlands	G.	246,768	135,405	6.99	2.69
New Zealand†	G.	74,111	104,488	13.19	10.19
Norway**	P.G.	83,707	126,901	20.62	5.09
Poland	P.G.	145,810	99,114	2.79	0.34
Spain*	P.	211,528	129,862	4.07	0.66
Sweden	G.	267,151	420,415	24.76	8.10
Switzerland	G.	188,550	223,774	21.04	6.81
Union of South Africa†	G.	104,082	65,337	7.42	0.79
United States	P.	10,581,802	7,851,598	20.31	10.33

NOTE: P. indicates that the telephone service is wholly or predominantly operated by private companies, G. wholly or predominantly by the Government, and P.G. by both private companies and the Government. See first table.
 * January 1, 1936. ** June 30, 1936. † February 28, 1937. ‡ March 31, 1937.

Telephone Conversations and Telegrams—Year 1936

COUNTRY	Number of Telephone Conversations	Number of Telegrams	Total Number of Wire Communications	PER CENT OF TOTAL WIRE COMMUNICATIONS		WIRE COMMUNICATIONS PER CAPITA	
				Telephone Conversations	Conver-Telegrams	Telephone Conversations	Total
Australia	514,000,000	16,203,000	530,203,000	96.9	3.1	76.1	2.4
Austria	650,000,000	1,645,000	651,645,000	99.7	0.3	95.5	0.2
Belgium	293,000,000	5,614,000	298,614,000	98.1	1.9	35.2	0.7
Canada	2,449,192,000	11,742,000	2,460,934,000	99.5	0.5	222.4	1.0
Czechoslovakia	285,000,000	4,018,000	289,018,000	98.6	1.4	18.7	0.3
Denmark	664,000,000	1,683,000	665,683,000	99.7	0.3	177.5	0.5
Finland	261,000,000	769,000	261,769,000	99.7	0.3	68.7	0.2
France	941,000,000	28,676,000	969,676,000	97.0	3.0	22.4	0.7
Germany	2,562,000,000	17,156,000	2,579,156,000	99.3	0.7	38.0	0.3
Great Britain and No. Ireland	2,000,000,000	58,805,000	2,058,805,000	97.1	2.9	42.6	1.3
Hungary	164,000,000	1,946,000	1,65,946,000	98.8	1.2	18.3	0.2
Japan	4,772,000,000	59,713,000	4,831,713,000	98.8	1.2	68.1	0.9
Netherlands	400,000,000	2,953,000	402,953,000	99.3	0.7	47.0	0.3
Norway	253,000,000	2,900,000	255,900,000	98.9	1.1	87.5	1.0
Poland	529,000,000	3,508,000	532,508,000	99.3	0.7	15.4	0.1
Spain	806,000,000	25,000,000	831,000,000	97.0	3.0	32.7	1.0
Sweden	1,000,000,000	3,858,000	1,003,858,000	99.6	0.4	159.8	0.6
Switzerland	281,000,000	1,703,000	282,703,000	99.4	0.6	67.3	0.4
Union of South Africa	262,000,000	6,549,000	268,549,000	97.6	2.4	27.3	0.7
United States	26,800,000,000	190,000,000	26,990,000,000	99.3	0.7	209.9	1.5

NOTE: Telephone conversations represent completed local and toll or long distance messages. Telegrams include inland and outgoing international messages.
 ☐ Year 1935.

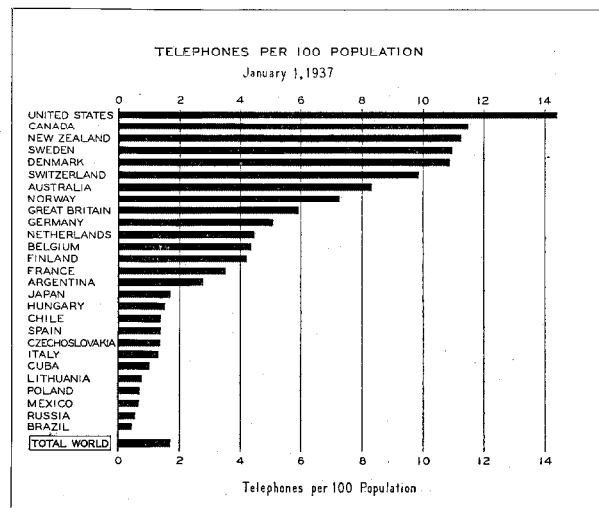

DISTRIBUTION OF THE WORLD'S TELEPHONES January 1, 1937

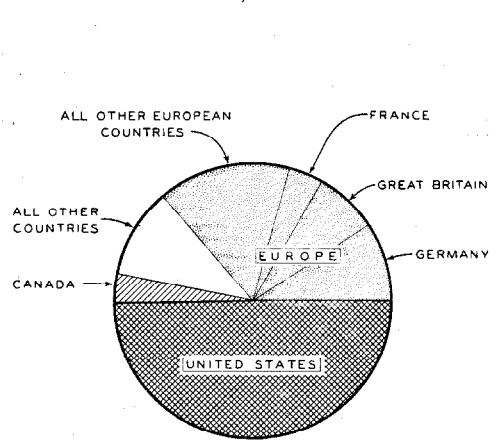

Telephone Development of Large Cities January 1, 1937

Country and City (or Exchange Area)	Estimated Population (City or Ex- change Area)	Number of Telephones	Telephones Per 100 Population	Country and City (or Exchange Area)	Estimated Population (City or Ex- change Area)	Number of Telephones	Telephone Per 100 Population
ARGENTINA :				ITALY :			
Buenos Aires.....	3,040,000	213,428	7.02	Milan.....	1,114,000	95,097	8.54
AUSTRALIA :				Naples.....	875,000	28,283	3.23
Adelaide.....	317,000	32,204	10.16	Rome.....	1,179,000	98,147	8.32
Brisbane.....	313,000	31,255	9.99	JAPAN †			
Melbourne.....	1,018,000	119,000	11.69	Kobe.....	938,000	40,564	4.32
Sydney.....	1,267,000	138,908	10.96	Kyoto.....	1,107,000	46,903	4.24
AUSTRIA :				Nagoya.....	1,120,000	39,969	3.57
Graz.....	153,000	11,657	7.62	Osaka.....	3,102,000	144,494	4.66
Vienna.....	1,877,000	190,192	10.13	Tokio.....	6,086,000	236,228	3.88
BELGIUM : ‡				LATVIA †			
Antwerp.....	529,000	44,310	8.38	Riga.....	388,000	26,903	6.93
Brussels.....	984,000	117,900	11.98	LITHUANIA :			
Liege.....	422,000	26,913	6.38	Kaunas.....	107,000	6,906	6.45
BRAZIL :				MEXICO :			
Rio de Janeiro.....	1,850,000	78,402	4.24	Mexico City.....	1,410,000	71,466	5.07
CANADA :				NETHERLANDS :			
Montreal.....	1,060,000	170,037	16.04	Amsterdam.....	783,000	59,209	7.56
Ottawa.....	191,000	37,634	19.70	Haarlem.....	168,000	13,317	7.93
Toronto.....	787,800	199,727	25.35	Rotterdam.....	621,000	41,895	6.75
Vancouver.....	190,000	56,317	29.64	The Hague.....	529,000	51,024	9.65
CHILE :				NEW ZEALAND †			
Santiago.....	829,000	30,351	3.66	Auckland.....	207,000	25,859	12.49
CHINA :				NORWAY : **			
Hong Kong.....	870,000	16,054	1.85	Oslo.....	250,000	55,967	22.39
Shanghai ††.....	1,660,000	56,020	3.37	PHILIPPINE ISLANDS :			
CUBA :				Manila.....	425,000	20,316	4.78
Havana.....	706,000	35,752	5.06	POLAND :			
CZECHOSLOVAKIA :				Lodz.....	960,000	16,621	1.73
Prague.....	950,000	73,057	7.69	Warsaw.....	1,320,000	73,672	5.58
DANZIG :				PORTUGAL :			
Free City of Danzig.....	275,000	18,432	6.70	Lisbon.....	670,000	32,504	4.85
DENMARK :				ROUMANIA :			
Copenhagen.....	856,000	191,908	22.42	Bucharest.....	800,000	34,055	4.28
FINLAND :				RUSSIA : *			
Helsingfors.....	275,000	42,607	15.49	Leningrad.....	3,100,000	99,463	3.21
FRANCE :				Moscow.....	4,100,000	144,669	3.53
Bordeaux.....	260,000	21,591	8.30	SPAIN : *			
Lille.....	202,000	17,544	8.69	Barcelona.....	1,110,000	55,569	5.01
Lyons.....	655,000	37,561	5.73	Madrid.....	1,015,000	66,148	6.52
Marseilles.....	920,000	36,507	3.97	SWEDEN :			
Paris.....	2,835,000	428,844	15.13	Gothenburg.....	263,000	50,026	19.02
GERMANY †				Malmö.....	144,000	24,275	16.86
Berlin.....	4,258,000	539,662	12.67	Stockholm.....	452,000	157,220	34.78
Breslau.....	624,000	45,182	7.24	SWITZERLAND :			
Cologne.....	782,000	69,492	9.12	Basel.....	153,000	35,258	23.04
Dresden.....	800,000	68,764	8.60	Berne.....	115,000	27,552	23.96
Dortmund.....	577,000	26,180	4.54	Geneva.....	149,000	28,748	19.29
Essen.....	672,000	33,139	4.93	Zurich.....	277,000	62,955	22.73
Frankfort-on-Main.....	651,000	64,252	9.87	UNITED STATES :			
Hamburg-Altona.....	1,630,000	168,322	10.33	(See Note)			
Leipzig.....	757,000	68,577	9.06	New York.....	7,238,000	1,569,337	21.68
Munich.....	844,000	86,718	10.27	Chicago.....	3,460,000	900,653	26.03
GREAT BRITAIN AND NO. IRELAND †				Los Angeles.....	1,365,000	394,403	28.89
Belfast.....	415,000	21,585	5.20	Pittsburgh.....	1,031,900	201,935	19.57
Birmingham.....	1,248,000	71,043	5.69	Total 10 cities over 1,000,000 Population.....	22,274,800	4,811,304	21.60
Bristol.....	443,000	27,047	6.11	Milwaukee.....	781,000	147,816	18.93
Edinburgh.....	457,000	40,495	8.86	San Francisco.....	710,000	262,733	37.00
Glasgow.....	1,130,000	64,761	5.73	Washington.....	572,500	214,308	37.43
Hull.....	352,000	22,166	6.30	Minneapolis.....	511,000	134,563	26.33
Leeds.....	487,000	32,399	6.65	Total 10 cities with 500,000 to 1,000,000 Population.....	6,623,100	1,455,118	21.97
Liverpool.....	1,249,000	72,433	5.80	Seattle.....	420,600	116,238	27.64
London— (City and County of London).....	4,155,000	657,235	15.82	Denver.....	312,500	96,737	30.96
Manchester.....	995,000	64,362	6.47	Omaha.....	242,900	64,553	26.58
Newcastle.....	516,000	24,571	4.76	Hartford.....	241,200	59,382	24.62
Sheffield.....	512,000	24,966	4.88	Total 34 cities with 200,000 to 500,000 Population.....	10,471,700	2,018,965	19.28
HAWAII :				Total 54 cities with more than 200,000 Population.....	39,369,600	8,285,387	21.05
Honolulu.....	147,000	18,818	12.80				
HUNGARY :							
Budapest.....	1,400,000	92,027	6.57				
Szeged.....	140,000	2,209	1.58				
IRISH FREE STATE †							
Dublin.....	472,000	23,412	4.96				

NOTE: There are shown, for purposes of comparison with cities in other countries, the total development of all cities in the United States in certain population groups, and the development of certain representative cities within each of such groups.

* January 1, 1936.

** June 30, 1936.

† February 28, 1937.

† March 31, 1937.

†† International Settlement and French Concession.

TELEPHONES PER 100 POPULATION
OF LARGE CITIES

January 1, 1937

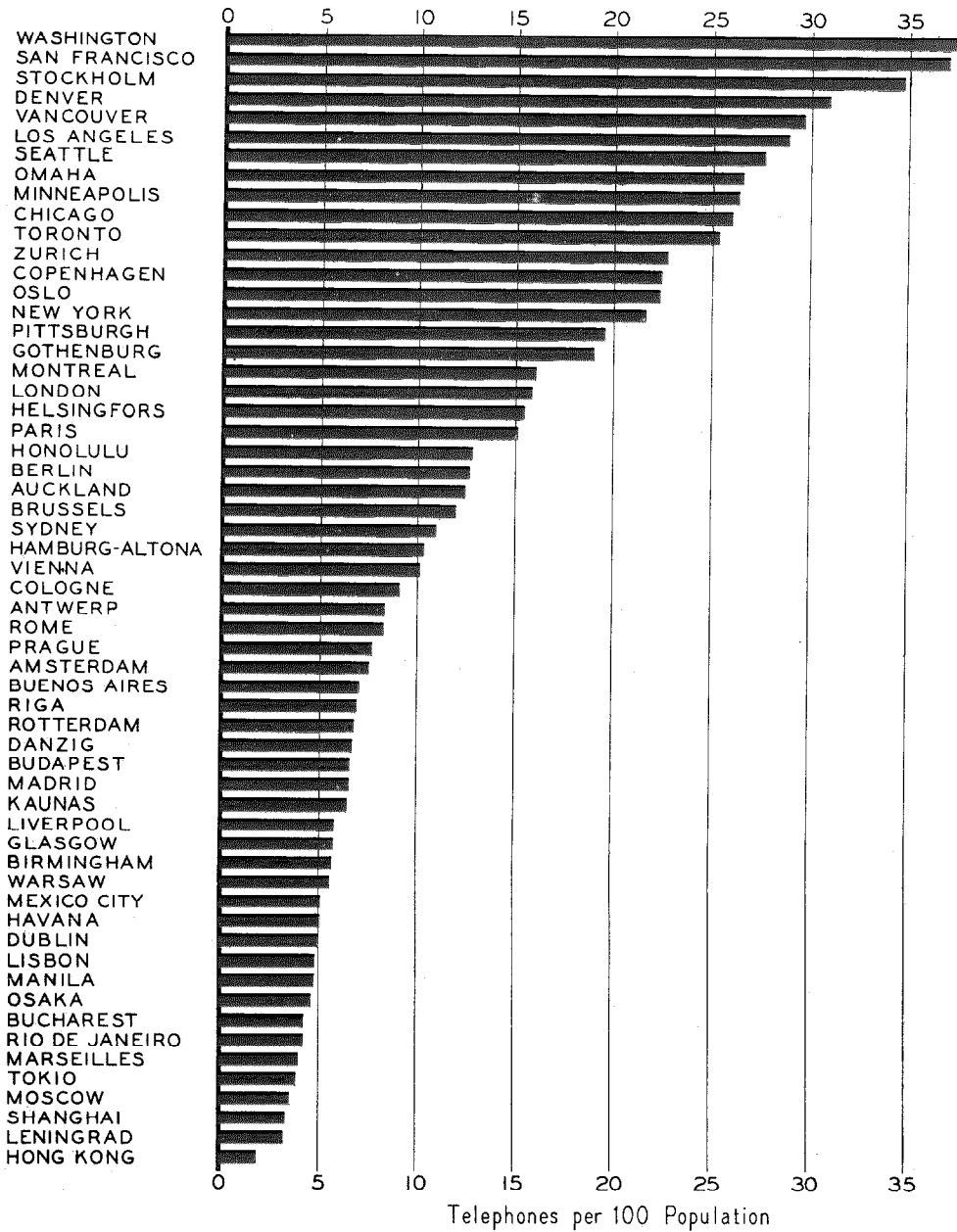

Recent Telecommunication Developments of Interest

Automatic Ticketing in Hungary.—The Hungarian Telephone Administration has decided to introduce automatic toll service in Hungary, utilising Automatic Ticketing equipment. Initially, orders have been placed with Standard Villamossági Részvény Társaság, Budapest, for one new 7-A2 type Rotary Exchange (Erzsébet) in Budapest itself, equipped for 17 600 subscribers (8 800 main lines and 4 400 two-party lines), a new 500 line 7-D Urban type Rotary Exchange for the provincial town of Pápa, and the toll equipment of a manual exchange, Szombathely, as well as the toll equipment of a new automatic exchange for Miskolc. These equipments are scheduled for completion in the following sequence :

During 1938, the Pápa exchange and the long distance dialling equipment in Budapest will be placed in service and will provide for operators' dialling in both directions from their toll boards directly to subscribers in the Budapest and Pápa areas ; also, from the Szombathely operator towards the Budapest and Pápa subscribers, working in tandem through Pápa.

Erzsébet exchange is planned for inauguration in 1939. At that time, additional equipment will be ready in the Miskolc toll exchange for the introduction of subscribers' long distance dialling and CLR toll service, both with automatic ticketing, from Erzsébet subscribers to the subscribers of Pápa and Miskolc.

• • •

R.108 and R.109 Receivers.—To meet special marine requirements, two complementary receivers for telephone and telegraph working have been developed by Standard Telephones and Cables, Ltd., London: the R.108 short wave (13 to 250 metres), and the R.109 medium/long wave (250 to 4 000 metres).

The receivers are of high sensitivity with an output exceeding 50 milliwatts for an input signal of 1 microvolt, modulated 30 per cent.

Single knob tuning is employed over the whole range, and the 8 in. tuning drum is frequency calibrated.

Variable selectivity giving 2 band-widths is provided in addition to a very narrow band-pass filter which is used for telegraph reception. Protection against static crash is obtained by a special limiter circuit.

The receivers are fitted with automatic volume control circuits for which two separate time constant values are provided to cope with different rates of fading and for C.W. reception.

The method of mounting the receivers is of interest inasmuch as it is designed for entire front accessibility for maintenance purposes. In addition the units may be removed forward from the case by means of suitable guides. The design and finish are especially suitable for use in tropical climates and in locations where heavy mechanical shock may be experienced.

• • •

Railway Signalling Systems.—In line with the rapid progress being made in the application of telephone technique to signalling systems for railway operation, the London and North Eastern Railway Company has placed an order with Standard Telephones and Cables Limited, London, for a new type of interlocking system for the track layout at Doncaster, Yorkshire. This system, developed by Standard Telephones and Cables Limited, utilises the well-known type of sequence switch employed in Rotary Automatic Telephone systems.

The controls for setting up the routes will be located on an illuminated track diagram, giving the signaller a comprehensive picture of the track under control.

The installation will comprise two signal cabins arranged to interlock 170 and 190 routes, respectively, together with automatic train describer equipment for the tracks feeding the two cabins.

The track diagram and describer equipment

will be mounted in appropriate desks. The sequence switches and associated relays will be housed in sheet steel cubicles.

• • •

Emergency Aviation Radio Transmitter.—A small and relatively powerful fixed wavelength radio telegraph transmitter, designed primarily as a stand-by transmitter for medium and large size aeroplanes, has been developed by Standard Telephon und Radio A.G., Zurich, to meet the requirements of the Swiss Air Authorities. It has the advantages of small size, light weight, relatively high power, simplicity of operation and ease of installation.

The equipment operates at 333 kc. (900 m.). It is crystal-controlled by a low temperature coefficient AT cut crystal, which guarantees a high degree of frequency stability without the use of a thermostat.

The output power is 30 watts H.F. and the output circuit is designed so that it can be tuned

to deliver this power into a wide variety of antennæ. The transmitter operates on CW telegraph only, but can be modified for combined telegraph and telephone working.

Aural monitoring is provided. The operator is thus enabled to hear the signals he is sending and tuning is facilitated since signals are only audible in the monitor with a correctly tuned transmitter.

A screwdriver adjustment gives the initial setting of the tuned anode circuit of the output amplifier. Thereafter the single tuning control, mounted below the antenna ammeter, provides easy tuning.

Power is supplied from a standard aeroplane 12-volt storage battery, the high tension being derived from a dynamotor.

The overall dimensions of the transmitter are $219 \times 245 \times 215$ mm. ($8.7'' \times 9.7'' \times 8.5''$). The total weight of the complete transmitter with shock-proof mounting is 4.3 kg. (9.5 lb.).

Licensee Companies

BELL TELEPHONE MANUFACTURING COMPANY.....	<i>Antwerp, Belgium</i>
<i>Branches : Brussels</i>	
BELL TELEPHONE MANUFACTURING COMPANY.....	<i>Berne, Switzerland</i>
BELL TELEPHONE MANUFACTURING COMPANY.....	<i>The Hague, Holland</i>
CHINA ELECTRIC COMPANY, LIMITED.....	<i>Shanghai, China</i>
<i>Branches : Canton, Tientsin, Hankow, Hong Kong.</i>	
COMPAGNIE DES TÉLÉPHONES THOMSON-HOUSTON.....	<i>Paris, France</i>
COMPAÑÍA RADIO AEREA MARITIMA ESPAÑOLA.....	<i>Madrid, Spain</i>
COMPAÑÍA STANDARD ELECTRIC ARGENTINA.....	<i>Buenos Aires, Argentina</i>
CREED AND COMPANY, LIMITED.....	<i>Croydon, England</i>
FABBRICA APPARECCHIATURE PER COMUNICAZIONE ELETRICHE.....	<i>Milan, Italy</i>
<i>Branch : Rome.</i>	
INTERNATIONAL MARINE RADIO COMPANY, LIMITED.....	<i>London, England</i>
JUGOSLAVIAN STANDARD ELECTRIC COMPANY, LIMITED.....	<i>Belgrade, Jugoslavia</i>
KOLSTER-BRANDES, LIMITED.....	<i>Sidcup, England</i>
LE MATÉRIEL TÉLÉPHONIQUE.....	<i>Paris, France</i>
<i>Branch : Rabat, Morocco.</i>	
NIPPON DENKI KABUSHIKI KAISHA.....	<i>Tokyo, Japan</i>
<i>Branches : Osaka, Japan ; Dalny (Dairen), Manchuria ; Taihoku, Formosa.</i>	
SOCIÉTÉ ANONYME LES TÉLÉIMPRIMEURS.....	<i>Paris, France</i>
STANDARD ELECTRIC AKTIESELSKAB.....	<i>Copenhagen, Denmark</i>
STANDARD ELECTRIC COMPANY W POLSCE SKA z O. O.....	<i>Warsaw, Poland</i>
STANDARD ELECTRIC DOMS A SPOL.....	<i>Praha, Czechoslovakia</i>
<i>Branch : Bratislava.</i>	
STANDARD ELECTRICA.....	<i>Lisbon, Portugal</i>
STANDARD ELÉCTRICA, S.A.....	<i>Madrid, Spain</i>
<i>Branches : Barcelona, Santander.</i>	
STANDARD ELECTRICA, S.A.....	<i>Rio de Janeiro, Brazil</i>
STANDARD ELEKTRIZITÄTS-GESELLSCHAFT A.G.....	<i>Berlin, Germany</i>
STANDARD FABRICA DE TELEFOANE SI RADIO, S.A.....	<i>Bucharest, Rumania</i>
STANDARD TELEFON-OG KABELFABRIK A/S.....	<i>Oslo, Norway</i>
STANDARD TÉLÉPHONE ET RADIO, S.A. Zürich.....	<i>Zürich, Switzerland</i>
STANDARD TELEPHONES AND CABLES, LIMITED.....	<i>London, England</i>
<i>Branches : Glasgow, Leeds, Dublin, Cairo, Pretoria, Calcutta.</i>	
STANDARD TELEPHONES AND CABLES (PTY.), LIMITED.....	<i>Sydney, Australia</i>
<i>Branches : Melbourne ; Wellington, New Zealand.</i>	
STANDARD VILLAMOSSÁGI RÉSZVÉNY TÁRSASÁG.....	<i>Budapest, Hungary</i>
SUMITOMO ELECTRIC WIRE & CABLE WORKS, LIMITED.....	<i>Osaka, Japan</i>
VEREINIGTE TELEFON- UND TELEGRAPHENFABRIKS AKTIEN-GESELLSCHAFT, CZEIJA, NISSEL & CO.....	<i>Vienna, Austria</i>

Sales Offices and Agencies Throughout the World