

*A. J. C. Brock (Please scratch to your copy)*

~~SL~~  
~~SL~~  
SL  
LCP

# ELECTRICAL COMMUNICATION

JULY  
1938

No. 1  
VOL. 17

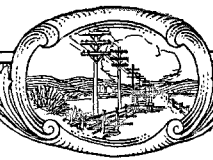

# ELECTRICAL COMMUNICATION

A Journal of Progress in the  
Telephone, Telegraph and Radio Art

H. T. KOHLHAAS, EDITOR

## EDITORIAL BOARD

E. A. Brofos   G. Deakin   E. M. Deloraine   P. E. Erikson   F. Gill  
W. Hatton   R. A. Mack   H. M. Pease   Kenneth E. Stockton   C. E. Strong

Issued Quarterly by the

*International Standard Electric Corporation*

67 BROAD STREET, NEW YORK, N.Y., U.S.A.

---

---

Volume XVII

July, 1938

Number 1

---

---

	PAGE
CAIRO TELECOMMUNICATION CONFERENCES.....	3
A WORKING STANDARD FOR TELEPHONE TRANSMISSION.....	16
<i>By L. C. Pocock</i>	
L.M.T. LABORATORIES 7-FREQUENCY RADIO-PRINTER.....	22
<i>By L. Devaux and F. Smets</i>	
MIX AND GENEST SWITCH TYPE (CITOMAT) P.A.B.X.'s.....	35
<i>By E. Funccius and E. Lawin</i>	
ELECTRICAL PROPERTIES OF AERIALS FOR MEDIUM AND LONG WAVE BROADCASTING .....	44
<i>By W. L. McPherson</i>	
BROADCASTING STATION LS-1—BUENOS AIRES.....	66
<i>By R. E. Coram, A. W. Kishpaugh and W. H. Capen</i>	
RECENT PROGRESS IN AUTOMATIC TICKETING IN BELGIUM.....	72
<i>By J. A. Marchal and G. E. H. Mönnig</i>	
NATIONAL DIALLING IN THE NETHERLANDS.....	78
<i>By J. P. Verlooy and M. Den Hertog</i>	
THE APPLICATION OF STYRENE TO H.T. CABLE SYSTEMS (PART III)..	88
<i>By T. R. Scott and J. K. Webb</i>	
RECENT TELECOMMUNICATION DEVELOPMENTS OF INTEREST.....	96





*New Southgate : One of the two London factories of Standard Telephones and Cables, Limited, the employees of which company number nearly 12 000.*

## Cairo Telecommunication Conferences

**O**N the 1st February, 1938, the Telecommunication Conferences were opened in Cairo by His Majesty King Farouk I.

In reality there were four conferences, viz., the Telephone Commission, the Telegraph Commission, the Radio Commission, the Telephone International Consultative Committee (C.C.I.F.); and documents were issued by the officials of the International Union of Telecommunications in respect of the meetings of each of these bodies.

The work of the three Commissions and of the C.C.I.F. is described briefly herein. No general outline of the formation and status of the various bodies is included since it seems more profitable to confine the exposition to what was actually done at Cairo. Again, little space is given to the great efforts which were made, ineffectively however, to solve some difficult problems. The Conferences were not authorised to study any changes in the Convention.

His Excellency Hassan Sabri Pasha, Minister of Communications, was appointed President of the Conferences, while His Excellency Mahmoud Chaker Pasha, Director-General of Railroads, Telegraphs and Telephones of the Egyptian State, and Mr. John Webb, Inspector-General of Telegraphs and Telephones, were appointed Vice-Presidents. Official duties precluded the Minister's daily attendance, but his place was well filled by Mr. Webb, who was present continually and who presided at the Plenary Meetings.

The arrangements made by the Egyptian

Government through the Ministry of Communications were very complete, and the Members of the Conferences were all highly appreciative of their excellence. During the conferences and at the end, thoroughly deserved thanks were tendered to the Minister and to the Inspector-General of Telegraphs and Telephones and his staff, all of whom were most assiduous in ensuring the comfort of the members.

The conferences were attended by about 550 members and, inasmuch as the number of sets of papers which reported discussions, etc., amounted to about 860, the Bureau of the International Union of Telecommunications had a very heavy job, which was excellently performed.

Through the courtesy of the American Delegation the documents, issued in French, were also available in English. At the close of the conferences and at the request of about 40 countries, it was decided that in future the Bureau de l'Union should make and issue translations in English of the documents issued during the general conferences and the meetings of the C.C.I.T. and C.C.I.R.; and, further, that the propositions for the general conferences and for the meetings of the C.C.I.T. and C.C.I.R. should also be published in English at the cost of those interested.

It was decided that a Vocabulary of Telecommunication should be made. The Swiss Administration will take charge of the Commission doing this work, the languages to be considered being English, French, German, Italian, Portuguese, Spanish, Swedish and Russian.

### TELEPHONE

#### The Telephone Commission and XIIth Plenary Meeting of the C.C.I.F.

##### *I. XIIth Plenary Meeting of the C.C.I.F.*

In conjunction with the plenary meeting of the International Telecommunications Union,

the C.C.I.F. held its twelfth plenary meeting in Cairo, on the 4th and 5th February, 1938.

In one sense it was not a full meeting of the

C.C.I.F. inasmuch as only the work of the 6th and 7th Commissions of Rapporteurs was considered. These two Commissions deal with questions relating to traffic, operating methods and tariffs in the international telephone service. In view of the fact that the Telecommunication Conferences were scheduled to deal with these subjects, a plenary meeting of the C.C.I.F. was desirable in order to pass upon the recommendations which had been prepared by the two above-mentioned Commissions.

One of the functions of the International Telecommunications Union, to which the C.C.I.F. is a consulting body, is the revision at approximately five-year intervals of the Telephone Regulations which are annexed to the International Telecommunication Convention. These regulations were last brought up to date at the plenary meeting of the Union in Madrid, 1932. In the intervals between conferences, Telephone Administrations and Operating Companies, concerned with international telephony, are invited to submit proposals to the Bureau of the Union, at Berne, for modifications of the Telephone Regulations, stating their reasons for the suggested changes. These proposals are compiled by the Bureau of the Union into a document (known as the "Blue Book") which forms the basis of the debates at the plenary meetings.

Representatives of 30 countries attended the Cairo plenary meeting of the C.C.I.F., which, in line with accepted practice, had as its president the head of the telephone organization of the country where the meeting was held—Mr. John Webb, Inspector-General of the Egyptian State Telephone Service. Mr. H. Fossion, Chief Rapporteur of the 6th and 7th Commissions, was elected Vice-President of the XIIth plenary meeting of the C.C.I.F.

The questions to be ratified by the plenary meeting had all been discussed by the two Commissions (6th and 7th) at their meeting in Paris, in September, 1937, and the findings were formulated in the Recommendations which, in accordance with standard procedure, must be submitted to the plenary meeting of the C.C.I.F. for approval. The final Recommendations, ratified in this manner by the plenary meeting of the C.C.I.F., were submitted to the Telephone Section of the plenary meeting of the

International Telecommunications Union for discussion and eventual incorporation, if passed, in the Telephone Regulations published by the Bureau of the Union as an Annex to the Cairo Convention.

No attempt will be made here to cover the detailed recommendations passed by this plenary meeting of the C.C.I.F. since the more important ones will be covered below in the summary of the work done by the Telephone Commissions of the Telecommunication Conferences which dealt with the revision of the Telephone Regulations. Two items decided upon by the C.C.I.F. meeting, one dealing with *statistics* and the other with *rapid service*, are, however, worthy of note.

The secretariat of C.C.I.F. collects, coordinates and publishes annual statistics relating to international telephony. At the Cairo Conference it was decided that, as from 1938, the traffic statistics shall include representative average waiting times actually experienced by subscribers on all international calls between the important European capitals connected by direct telephone circuits.

A sub-committee was set up to study a number of fundamental problems which must be solved in order to obtain rapid service. The members of this committee were chosen from countries where rapid service is already in force in the internal network. The operating as well as the engineering departments of the countries represented on this sub-committee will collaborate with the representatives of the Mixed Commission for the General Fundamental Toll Switching Plan for Europe. Provisionally the sub-committee will be attached to the 6th Commission of Rapporteurs of the C.C.I.F.

The XIIIth plenary meeting at Lisbon in 1940 will examine a Draft of Instructions to be prepared by the sub-committee for rapid telephone service in Europe.

Rapid international telephone service in Europe has made distinct progress but much additional work remains to be done to perfect it.

## **II. Summary of the Work of the Telephone Commission of the Telecommunication Conferences**

In this brief outline it is only possible to record the more important modifications of the

Madrid (1932) Telephone Regulations. As a matter of convenience, the Articles of these Regulations are dealt with *seriatim*.\*

#### Article 1

Article 1 § 4 of the Madrid Telephone Regulations states, in effect, that provisions of the Telegraph Regulations which are not contrary to the stipulations of the Telephone Regulations and which relate to the same objects are applicable to the telephone service. Thus the Telephone Regulations are, in a measure, dependent on the Telegraph Regulations. Some Administrations feel that the former should have an independent code of regulations for international service and therefore put forward to the Telecommunication's plenary meeting a proposal to suppress paragraph (4) of Article 1. This proposal was put to a vote in the Telephone Commission and was adopted by a majority vote.

#### Article 11 Urgent Calls for Aeroplane Pilots

With the general development of aeroplane services it has become important that, in case of forced landings, pilots should have a means of rapid communication with their home port or any other airport. A new Article (No. 11) in the revised Regulation provides that telephone calls made under the above circumstances shall be regarded as Urgent Calls with priority over Urgent Private and Official Calls.

#### Article 16 Service Calls

Article 15 of Madrid (No. 16 of Cairo) relating to Service Calls was extended to include the free use of the telephone service, in case of absolute necessity, for the transmission of official telegrams and service telegrams as well as conversations relating thereto. Reciprocally, in the same circumstances, the telephone service may make free use of the telegraph service to send telegrams concerning the international service. This provision applies, however, only in case both the telephone and the telegraph services are handled by government administrations.

The Director of the Bureau of the International Union and the General Secretary of the C.C.I.F. shall have privileges similar to those of officials authorized to request telephone service.

\* The Article numbers given in the heading are the revised serial numbers (1938).

#### Article 20 Reversed Charge Calls

A new Article (No. 20) has been added to the Telephone Regulations, permitting a calling party to specify that the message charge is to be paid by the called party. This facility is subject to the previous consent of the latter and is rendered over international circuits by mutual agreement between Administrations and/or Operating Companies which have agreed to provide such service on international calls. These Reversed Charge calls are subject to the general provisions applicable to the international telephone service.

#### Article 31-48 Telephone Charges

On the initiative of Mr. Fossion, Chief Rapporteur of the 6th and 7th Commission of the C.C.I.F. and with the support of the representatives of Greece and Switzerland, Articles No. 29 and 30 of the Madrid Regulations were expanded and re-classified for more convenient reference. They now appear in the Cairo (1938) Regulations as Articles No. 31 to 48, inclusive.

Apart from editorial modifications, brought about by this rearrangement, new material has been added as outlined below.

#### Article 39 § 1

It is established that the unit charge shall be the charge for an ordinary conversation of three minutes' duration handled during the period of heavy traffic.

#### Article 33 § 2-b

With respect to rates applicable in periods of heavy and light traffic it is added that, on circuits other than those between adjacent frontier exchange areas, additional minutes shall be chargeable according to rates in force at the moment when each of these minutes began. On the other hand, in the case of calls between adjacent frontier exchange areas, where charges are payable by indivisible 3-minute periods, each 3-minute period shall be chargeable according to the rates in force at the moment when this 3-minute period began.

#### Article 37

"Lightning" calls, which under Article 30 § 3 of the Madrid Regulations were subject to a charge ten times that of an ordinary call of the same duration, are now, according to Article 37 of the Cairo Regulation, to be charged at five

times the rate for an ordinary call of equal duration.

*Article 39 § 1-b*

Subscription calls, which under the old Regulations were always charged at double rate during periods of heavy traffic, are now only to be subject to a double rate when Administrations or Operating Companies agree to do so under special circumstances.

*Articles 40, 41, 42*

The Madrid Regulations specified a minimum supplementary charge of 50 centimes for appointment calls, calls with préavis, avis d'appel and requests for information. These minimum charges are abolished through the Cairo Regulations.

*Article 40 § 2-2*

Appointment calls are now subject to a regulation which stipulates that the rates, applicable during a period of light traffic and ordered for at least one hour, shall be equal to one-half the rates for ordinary private calls of the same duration, completed during the period of heavy traffic. There is no surcharge in this case.

*Article 41*

The Cairo Regulations add a provision to the old regulations covering handling of préavis calls. They allow the redirection of a call to a second number in the same country in the case where the subscriber cannot be reached at the first number called. If a préavis call is so redirected to a subscriber in another local exchange area in the same country the charge is to be computed as follows :

- (a) If the call matures into a conversation, the charge shall be at the rates applicable to the effective conversation ;
- (b) If, on the contrary, no conversation takes place, the préavis charge shall be computed on the basis of the higher of the two rate schedules applicable to the connection involved.

*Article 43*

The surcharge of 1/3 of the unit rate, formerly applied in some instances to Stock Exchange calls, was abolished by the Cairo Regulations, which add that the rates applied shall be effective as from the moment when the call is made available to the broker.

*Article 44*

The rates, applicable to the newly introduced " Reversed Charge " calls, are to be the same as those obtaining in the same classifications and for the same lengths, plus a surcharge equal to the tax for one minute's ordinary conversation, effected during the same period. If the call is refused by the called subscriber, the surcharge, as above, shall be collected from the calling party.

*Article 46*

With respect to Double Surcharges, the Cairo Conference adopted a proposal to the effect that when a communication is requested in a classification for which a surcharge is payable (e.g., appointment calls or reversed charge calls accompanied by préavis or avis d'appel) only one surcharge is payable, i.e., with respect to the préavis or the avis d'appel.

*Article 47*

The right of an Administration or of an Operating Company to round off telephone rate charges to suit monetary or other conveniences was adopted at Cairo analogously with the corresponding provisions of the Telegraph Regulations. Such adjustments are to be made on charges collected in the country of origin. They must be so made that, for one unit of conversation, the differential shall not exceed 1/15 of the gold franc equivalent fixed by an Administration or Operating Company.

*Article 48*

The determination of monetary equivalents was the subject of detailed examination and it was ultimately decided to insert a new clause in the regulations, identical in wording with Article 31 of the Telegraph Regulations. The new Article (No. 48 in the Cairo Telephone Regulation) therefore reads as follows :

" In order to ensure the uniformity of charge, prescribed in Article 31 § 3, the countries of the Union fix, for the collection of their charges, an equivalent in their respective currencies approximating as nearly as possible to the value of the gold franc.

Each country notifies the Union of the equivalent chosen. The Bureau of the Union prepares a table of equivalents and transmits it to all Administrations of the Union.

The equivalent of the gold franc may in each

country undergo changes corresponding to the rise and fall in the value of the currency of the country. The Administration which modifies its equivalent fixes the date from which it will collect charges according to the new equivalent, and notifies the Bureau of the Union, which informs all other Administrations."

#### *Article 49 Rates for Special Cases*

The Madrid Article dealing with rates for special cases, exemptions and refunds was slightly modified in certain respects. If, for instance, a call subject to surcharge is cancelled, this surcharge is payable if particulars of the call have already been transmitted by the line-terminal office. Likewise there is a new clause which provides that ordinary calls booked to a wrong number, if completed, are chargeable as 3-minute calls. If the wrong request is immediately replaced by another request for a call to the same country, a charge for only one minute's conversation is payable for the incorrect request.

#### *Article 50 Establishment of Accounts*

In the Chapter (X) dealing with Accounting, a new clause is inserted to the effect that: The gold franc, as defined by Article 32 of the Convention, shall serve as the monetary unit in establishing international telephone accounts.

#### *Article 54 Expenses of the Bureau of the Union*

New material has been added to the Telephone Regulations with respect to the expenses of the Bureau of the Union so far as its services concern the telegraph and telephone services. The annual expense is limited to 200 000 gold francs. If, in a particular year, exceptionally high expenditure be necessary for printing of documents, and the above noted amount be exceeded without corresponding increase in revenues collected in the same year, the Bureau is authorised to exceed the maximum credit specified provided the maximum credit for the following year is diminished by an amount equal to such excess. The amount of 200 000 gold francs may be changed between conferences with the consent of all the contracting parties.

#### *Article 56 C.C.I.F.*

Article 56 dealing with the C.C.I.F. was modified in some respects by the Cairo Conference. Under the former rules, an Administration or Operating Company desiring to become

a member of the C.C.I.F. addressed its application to the Administration of the country in which the last plenary meeting was held. Such applications in the future will be addressed to the Bureau of the Union, which in turn advises all Administrations and the C.C.I.F. accordingly.

#### *Article 57 Conferences*

The procedure to be followed with respect to invitations to Conferences was fixed by the following regulations adopted at Cairo:

The Government of the country in which the meeting is to be held determines the date of the meeting.

Eighteen months prior to that date it shall issue invitations to the Governments adhering to the Union. These, in turn, shall notify the private Operating Telephone Companies which abide by the Regulations and also international bodies which may be interested.

The Government issuing these invitations has the right to extend them to Governments which are signatories to the Convention or which have approved that document without up to that time having adopted the Telephone Regulations.

The Governments invited shall attach to their reply a list of recognized private Operating Companies desiring to attend the meeting. The above-mentioned international bodies shall send applications for attending the meeting through their respective Governments to the Government issuing the invitations. Applications shall be sent in within five months of the date of issue of the invitations.

Six months prior to the date of the meeting, the inviting Government shall advise all Governments of the requests from the international bodies and ask them for their comments on the acceptance of the requests. These comments shall be sent to the inviting Government 4 months before the date of the plenary meeting.

The following bodies are admitted to these conferences:

- (a) Delegations from Governments which have accepted the Telephone Regulations, Governments which are signatories to the Convention, although not yet having accepted these Regulations, and delegates from private Operating Companies recognized by their respective Governments.



- (b) International organizations, the attendance of which has been sanctioned by at least one-half of the Governments replying to the invitations.

Other international bodies are admitted subject to approval of the plenary meeting.

*ANNEX—Internal Regulations of the C.C.I.F.*

The Telephone Regulations of Madrid specified, in the Annex to these Regulations, that the plenary meeting of the C.C.I.F. should appoint the Commission of Rapporteurs to deal with authorized questions. The Cairo Conference added that the plenary meeting also shall designate the Administrations and Operating Companies to be represented on these Commissions and shall appoint the Chief Rapporteur of each Commission. Under the former procedure the latter was elected within each Commission.

Revised clause Article 3 § 2, dealing with the work of the Commission of Rapporteurs, now reads: "In each C.R. the Chief Rapporteur assumes the direction of the work of the Committee and has power to call together the rapporteurs with the authority of his Administration."

At the plenary meeting, on 23rd February, 1938, of the Telephone Commission of the Cairo Conference an interpretation of this clause was asked for. After an exchange of views

between the delegations of Germany, Belgium, Great Britain, Chile and the United States, it was decided that the above cited clause should be understood to mean that a Chief Rapporteur, appointed by the plenary meeting of the C.C.I.F., may be chosen either from an Administration or a private Operating Telephone Company.

The election and duties of the General Secretary of the C.C.I.F. remain unaltered, but an additional clause has been added to the Madrid Annex to the effect that, since one of the tasks of the Telecommunication Conferences is to revise the text of the International Telephone Regulations, the General Secretary shall attend such conferences.

**III. Official Approval of Revised Regulations**

The Government representatives of 63 countries signed the Telephone Regulations (Cairo Revision, 1938). Six countries—Australia, Brazil, China, French Colonies, Iran and New Zealand—authorized their delegates to sign the Telegraph Regulations, but not the Telephone Regulations.

The delegates of Egypt, Great Britain and Northern Ireland appended their signatures with the reservation that they did not thereby approve Article 31 (Uniformity of Rates) or Article 48 (determination of monetary equivalents).

## TELEGRAPH

The main work of this section of the Telecommunication Conferences at Cairo dealt with Regulations and Tariffs which were handled in two separate Commissions.

In the Regulations Commission the changes made were of relatively minor importance and were mainly designed to clarify and simplify the Regulations in the interests of good service. Some of the changes merely gave effect to common practice and others cleared up points which were doubtful or conflicting.

In the Tariffs Commission the important question of unification of categories for the extra-European régime formed the main subject

of discussion for many weeks. This question had been exhaustively studied and discussed prior to the Cairo Conference, and the C.C.I.T. meeting at Warsaw in 1936 had made a report to the Cairo Conference, without reaching a unanimous recommendation as to how such unification was to be consummated. The Tariffs Commission had, therefore, to address itself to this problem. The various proposals, notably those by Great Britain and Germany, were thoroughly canvassed in the meetings of the Tariffs Commission after declarations had been made for and against unification, when it was found that 36 administrations supported the

general principle of unification of the plain, code and cipher categories, while 10 supported the status quo.

As the discussions on the various proposals to give effect to the unification of categories proceeded, the gold franc basis for rates was inevitably brought under review. After considerable debate it became evident that, in view of the disorganised state of the world's currencies relative to each other, a return to the gold franc basis, which functioned well when the world's currencies were effectively on a gold basis, could not be expected; and, in the end, the reservations made at Madrid were maintained. Each country thus decides its own course of action.

After prolonged discussions in the Tariffs Commission and in a special committee it was found impossible to reach a unification formula acceptable to all the administrations which supported the principle of unification and, finally, a vote in the Tariffs Commission was called for.

The principle of unification was adopted by 25 votes to 19. Each proposal for unification was then voted upon and defeated.

A last minute compromise proposal put forward by Great Britain and Germany for a  $63\frac{1}{3}$  per cent. unified rate with an optional "deferred" category was also defeated by 32 votes to 13 and it was then definitely decided to maintain the status quo for the extra-European régime, so far as the Cairo Conference was concerned.

For the European régime, a unified rate for plain and secret language at 92 per cent. of the present ordinary full rate for plain language was adopted with a 5-word minimum. In the European régime there will, therefore, be only two categories in future, namely, full-rate and letter-telegrams.

It seems likely that a strong effort will be made to have unification in the extra-European régime formally adopted at the next Conference, which will be held at Rome in 1942.

The Cairo Conference decided that the rate for urgent service should be double the ordinary or code rate, and that, in future, deferred messages will be subject to a minimum of five words.

The situation left is that the European Régime after January 1st, 1939, will have full-rate and letter-telegram categories, while the extra-European régime will continue to have the Madrid categories until modified by special or regional arrangements, or by the Rome Conference in 1942.

As a C.C.I.T. Conference will probably be held in 1940, it is possible that the question of extra-European rates may then be reviewed in a consultative capacity preparatory to the Rome Conference.

An important question dealt with by the Tariff Commission concerned Teleprinter Exchange services. At the C.C.I.T. meeting held in Warsaw it was proposed that regulations and tariffs for subscribers' Teleprinter services over international lines should be fixed during the Cairo Conference and that in the meantime administrations should be guided by a comprehensive report prepared by the 8th Commission of Rapporteurs. Detailed regulations were drawn up by the German Administration on the basis of this report and were presented as an annex to a proposition empowering administrations to establish subscribers' teleprinter services between themselves and to choose the method of operation (over telegraph or telephone lines) most convenient in their own country. It was the opinion of the delegates, however, that as teleprinter exchange services are still in an early state of development it would be premature to prescribe rigid regulations and accordingly an alternative proposition, presented by the French Administration, was adopted and now appears in the International Regulations under Article 64, as follows:

- (1) Countries in the European régime may organise a telegraph subscribers' service permitting users to communicate directly between themselves by means of teleprinter systems;
- (2) The rates and conditions of service shall be fixed by agreement between the administrations concerned, taking into consideration as far as possible the recommendations of the C.C.I.T.

The Conference also adopted unanimously a proposition recommending that the question of

teleprinter exchange service between countries in the European régime should be studied by a special committee of the C.C.I.T., to be constituted as quickly as possible and to comprise technicians and traffic specialists, in order that draft technical and operating regulations, as well as a study of the costs of providing teleprinter exchange service, may be communicated to administrations for consideration well before the C.C.I.T. meeting to be held in Lisbon in 1940.

A few amendments were made to the Madrid Regulations concerning transmission signals and it is of interest to mention that in International Alphabet No. 2 the "upper case" position of signal No. 4 (letter D) has been allotted to the function of releasing the answer-back mechanism in teleprinter systems. In the Morse code

the signal .-.-.- replaces the signal . . . . . formerly employed for the full stop but which had ceased to be used for many years in machine Morse working.

Draft regulations drawn up by the C.C.I.T. for photo-telegraph service were accepted, with a few slight amendments, for insertion in the Cairo revision of the International Regulations and are incorporated in Articles 65 to 73 defining the maximum dimensions of photo-telegrams, the conditions of acceptance, instructions concerning circuits and transmission, computation of tariffs and the conditions to be fulfilled in the case of private photo-telegraph services. The arrangements for photo-telegraph services in the extra-European régime will be determined by direct agreement between the administrations concerned.

## RADIO

### *General*

No changes of any material importance were made in the Regulations governing the operation of the radio services except that the operating organisation of the Aeronautical Services, the development of which has been so remarkable during the past five years, came under special consideration. Article 17 of the Regulations, whilst still requiring these services to adopt the procedure laid down for the mobile services in general, makes provision for exception in cases where some special local procedure, approved by the interested administrations, is in force.

Advantage was also taken of the greatly extended use by small ships of radiotelegraphy and radiotelephony in the band (1 600-4 000 kc. (187.5-75 m.)) to organise regular watch keeping on the wave adopted as the distress wave for these ships 1 650 kc. (182 m.) and so extend the usefulness of what has already proved to be a valuable safety service for coasting vessels, trawlers and other small craft operating in this band. It is estimated there are at least 1 500 such vessels in the north-west of Europe alone.

The tolerance table recommended for inter-

national adoption by the C.C.I.R. conference at Bucharest, in 1937, was modified in favour of somewhat less severe conditions for ships' stations, it being recognised that, in the case of these stations, practical and economic conditions both render a very high standard of equipment impossible to maintain. The trend of legislation was, in fact, to confine both ships and aircraft to certain exclusive bands in order that their operation should be self-contained and affect other services as little as possible.

At Madrid (1932) the tolerance table recommended by the C.C.I.R. (Copenhagen Conference, 1931) was merely proposed to administrations as a guide indicating the limits to be observed as far as possible. At Cairo (1938), however, the table drawn up by the C.C.I.R. (Bucharest Conference, 1937) was, with certain modifications, adopted as a firm regulation.

It was also agreed that the field of the C.C.I.R. should be extended to cover those questions of operation (but not tariffs) which involved technical considerations.

The real work of the radio section of the Conference lay in the allocation of frequencies

to the various services, the standard of efficiency of equipment (as indicated by the Table of Tolerances) and the abolition of type B (spark) emission, all of which proved to be extremely controversial subjects.

The chief problem was perhaps found in the increasing difficulties presented by allocation<sup>1</sup> of the range of frequencies between 150 and 5 500 kc., especially in Europe, and arose mainly out of the necessity for making provision for increased facilities for the aeronautical and broadcast services. It is of interest to note that at Madrid this range of frequencies was divided into 27 bands in Europe and 21 in other regions. At Cairo the relative figures were 51 and 30.

The revised technical regulations will come into force on 1st January, 1940, in the case of new installations; and on 1st January, 1944, in the case of existing equipments.

The following short résumé of the work of the technical committee will be of general interest.

#### **Allocation of Frequencies**

At the conferences of Berlin (1906) and London (1912) International legislation was practically confined to a consideration of mobile marine (ship-shore) interests. The war then intervened and under its stimulus technical development so completely revolutionised the art that, when the nations met at Washington in 1927, it was not only possible, but necessary, to make provision for fixed, broadcasting and aeronautical radio services, as well as marine.

Fig. 1 summarises the frequency allocation (10-30 000 kc.) assigned to the various services at Washington, Madrid and Cairo. It will be noted that the Cairo allocation does not differ very greatly on general lines from that made at Washington ten years previously. Broadly speaking, the fixed services maintained their

<sup>1</sup> It is to be noted that the radio frequency allocation 10-5 500 kc. (30 000-54.55 m.) is made under two separate headings:

1. European, which may be said to include an area bound on the north and west by the natural limits of Europe, on the east by the meridian 40° E., and on the south by the parallel 30° N.

2. Other Regions of the world.

The "Other Regions" allocation is rather more general than the "European" and is subject to future regional arrangements. For this reason the European allocation will be followed in the ensuing pages and it may be assumed that these other regional allocations will not differ materially from the European.

position whilst any additions for other services were provided by a revision of the marine bands.<sup>2</sup> Allocations above 30 000 kc. were envisaged at both Washington and Madrid and were elaborated at Cairo, but are still tentative as operation on these frequencies continues to be largely experimental.

The allocation of any given wave band is necessarily governed to some extent by the propagation properties of the wave band in question. At the Bucharest meeting of the C.C.I.R., a large amount of material relating to wave propagation was presented for consideration and information. It was too extensive and weighty to be digested in the short time available at the meeting and was therefore referred for subsequent and special study by a small group under the direction of Dr. Van der Pol. The conclusions arrived at were published in the Cairo Conference Radio Document No. 2 and cover wave propagation over the whole range of frequencies up to and including the ultra-short wave region. This document takes account of all known factors, including the curvature of the earth and atmospheric refraction and diffraction; it will be the only generally accepted basis for range forecasts for some time to come.

#### **Fixed Station Service**

In connection with the very large, fixed station frequency allocation assigned at Washington in the first instance and subsequently maintained at Madrid and Cairo, despite the constantly increasing claims of other services with a far greater number of stations, some comment seems desirable.

Fixed services lend themselves very conveniently to centralisation, and a number of communication channels are often concentrated on a single site. The number of channels is therefore appreciably greater than the number of stations; and, in order to maintain a continuous long distance service, each channel requires several separate frequencies for use at different times of the day and seasons of the year. Furthermore, the frequencies used by fixed stations are very largely located in bands

<sup>2</sup> A detailed study of the frequency allocations assigned to the various services has been made the subject of a chart. A copy of this chart can be obtained on application from any of the Companies listed elsewhere in this journal.

having a world-wide range, thus rendering it impossible to assign these frequencies to more than one station.

For these reasons the frequency allocation for fixed stations, large though it may appear in relation to the number of stations, was not challenged, the Conference being satisfied that the allocation was not more than adequate for the service.

The tolerances for these stations were made the subject of definite regulation and are more severe than those recommended at Madrid in the following respects :

For the frequencies

1 500- 6 000 kc.—.01% instead of .03%

6 000-30 000 kc.—.01% instead of .02%

**The Marine Mobile Service**

The Cairo revision of the radio regulations

affects the marine service in the following manner :

- (a) The bands which have hitherto been normally used by ship transmitters remain practically unaltered, although somewhat reduced in width ;
- (b) The frequency tolerance in these bands has been kept at a low figure ;
- (c) The aeronautical services have been largely removed from these bands in the European region ;
- (d) Ships using any parts of the general mobile bands other than those referred to in (a) are subject to the very much higher technical requirements of fixed stations ; and, except in the case of the largest passenger vessels, the necessary equipment is neither economical nor practical.

**RELATIVE DISTRIBUTION OF RADIO FREQUENCIES (EUROPE) IN KILOCYCLES**

- (1) WASHINGTON, 1927.
- (2) MADRID, 1932.
- (3) CAIRO, 1938.

**NOTES**

- (1) Exclusive bands are shown "hatched," with band width in unbracketed figures ; shared bands "open" with band width in brackets.
- (2) Until the Cairo Conference the Marine and Aeronautical services operated in the General Mobile band. Their exclusive allocations were extremely small.
- (3) The practical effect of the Cairo Conference will be to confine Ship Services to the low-tolerance marine bands and the Aeronautical Services to the exclusive aeronautical bands. The Aeronautical Services also have an allocation of 16 500 kc/s in the ultra-short wave bands. It is improbable that either the Marine or Aeronautical Services will operate on frequencies other than those in the above bands.

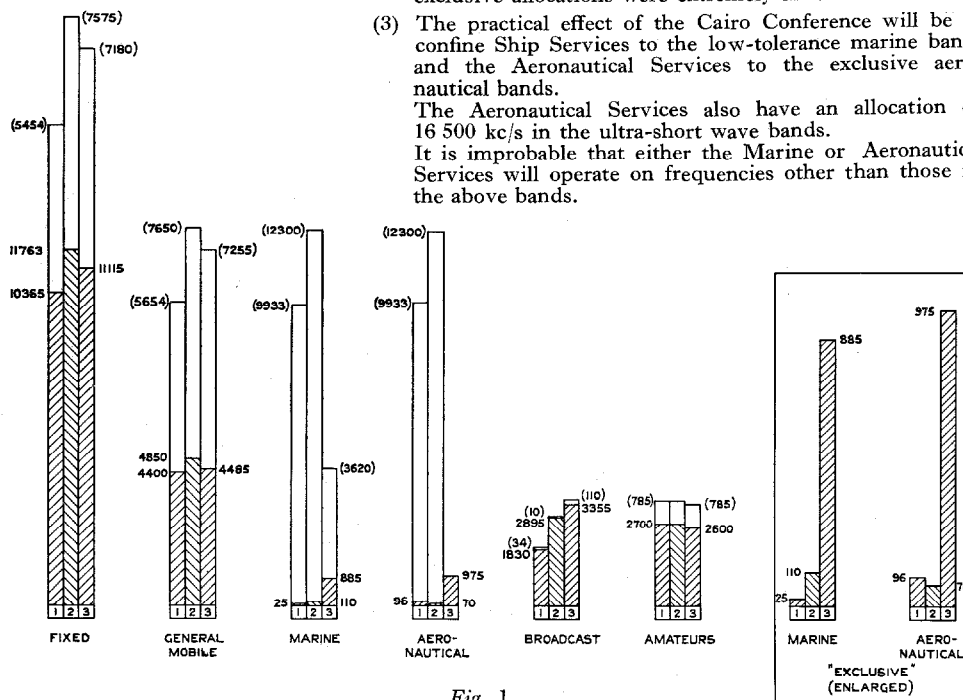

Fig. 1.

In effect these regulations, through considerations of cost, bias the design of ship installations in the direction of comparatively low stability combined with narrow operating bands. On the other hand, the exclusive nature of the latter will reduce the possibilities of interference to and by other services.

The special low tolerance bands cover in all 3 620 kc. of which 885 kc. are definitely exclusively for ship use, and the remaining 2 735 kc. shared with other services.

These international low tolerance ship bands provide :

- (1) For long distance communication up to 2 000 miles—60 kc. between 100–160 kc. (3 000–1 875 m.) ;
- (2) To meet compulsory requirements—150 kc. between 365–515 kc. (822–583 m.) ;
- (3) For small ships, local communications, radiotelephony, etc.—2 500 kc. between 1 500–4 000 kc. (200–75.54 m.) ;
- (4) For world-wide communication—910 kc. between 4 000–22 200 kc. (75.54–13.51 m.).

The actual allocation may differ somewhat in different parts of the world, particularly in respect of (3).

Special provision is also made for these exceptional ships, such as large passenger liners, the equipments of which comply with the stability requirements of fixed stations. For these ships 550 kc. are reserved between 4 000–23 000 kc. (68.18–13.04 m.)

For the foregoing reasons the Marine allocation under the Cairo Regulations is shown in Fig. 1, as defined by the low tolerance bands, since it is improbable that ships' equipments will be designed to operate outside the limits of these bands.

A large body of opinion amongst the delegates was in favour of the total and immediate abolition of type B (spark) transmission on the familiar ground that it was obsolete and caused much unnecessary interference. This was successfully resisted by the shipping interests on whom the cost of any new equipment would fall. The representatives of the International Shipping Conference pointed out that an agreement had been reached at Washington to the effect that spark should be abolished except

on small powers (300 watts at the terminals of the alternator) on 1st January, 1940. They estimated that there were still about 6 000 ships using the more powerful type of spark set, and that any sudden change calling for entire replacement of spark by modern equipment would not only be unreasonably expensive but would also embarrass the manufacturing radio companies called upon to supply the equipments and make the change effective. Mutual concessions were, however, made towards what is generally agreed to be a desirable end, and spark transmission will be definitely restricted after 1st September, 1939, to the frequencies of :

- 375 kc. (800 m.) for radiogoniometry ;
- 425 kc. (706 m.) for traffic purposes ;
- 500 kc. (600 m.) for calling and distress.

It was further agreed to abandon the use of spark on all waves except 500 kc. (600 m.) as soon as possible. The original agreement to retain spark for equipments of less than 300 watts, however, still remains good.

In the ultra-short wave band provision is made in Europe for radio beacons operating between 32 and 32.5 Mc. (9.375–9.231 m.). These beacons are for harbour entrance navigation, their maximum range being of the order of 10 kilometres.

### *The Aeronautical Services*

At the Cairo Conference the Aeronautical services emphasized the extent to which they are handicapped by the restrictions inseparable from the conditions of their service. The power available in an aircraft radio installation is very small compared with any other service and, consequently, interference is a specially serious problem, while at the same time the remarkable growth in air transport since 1932 has rendered the small exclusive frequency allocation assigned at Madrid quite inadequate to the needs of 1938.

It was consequently agreed to make the following exclusive allocations for the use of aircraft in Europe :

- (1) 90 kc. in the band between 160 kc. (1 875 m.) and 2 000 kc. (150 m.)
- (2) 885 kc. in the band between 2 000 kc. (150 m.) and 25 000 kc. (12 m.)
- (3) 16 500 kc. in the band between 25 000 kc. (12 m.) and 200 000 kc. (1.5 m.),

making a total of 17 475 kc. In arriving at this satisfactory conclusion it was agreed that in return for these exclusive allocations, the Aeronautical services would resign their other rights in the general mobile bands above 6 000 kc. (below 50 m.) in the European region.

In addition to allotting exclusive bands the Conference also specified sixty spot frequencies, in the exclusive bands between 6 000 kc. (50 m.) and 25 000 kc. (12 m.), for use on the international transoceanic air routes already in existence or foreseen.

It is to be remembered that the term "Aeronautical service" includes not only ground to aircraft and inter-aircraft services but also any special services required in connection with air navigation.

#### **Broadcasting**

The great public interest taken in broadcasting was reflected in the large attendance at all meetings when this question was under discussion. It was found extremely difficult, especially in the case of Europe, to meet the demands of this important service without prejudicing the efficiency of other services equally important though perhaps less spectacular. Eventually the following additional allocations were agreed on :

*In Europe*—60 kc. between 1 500 and 1 560 kc. ;

*In the Tropics*—Entirely new bands covering 595 kc. for local broadcasting services ;

*For Long Distance Short Wave Broadcasting*—500 kc.

For Europe the allocation of individual station frequencies within the band 160–1 560 kc., and possibly power limitation also, will be dealt with by the European Broadcasting Conference to be held in Switzerland in February, 1939.

For short wave broadcasting no definite plan for allocating station frequencies was proposed but the Conference expressed the wish that the U.I.R. should centralise the technical study of this problem and prepare the way for a world-wide conference which would make definite allocations.

#### **Amateurs and Experimenters**

Notwithstanding the increasing pressure of national and international requirements, the

frequency bands allocated to Amateurs and Experimenters remain substantially those originally allocated at Washington. This constitutes a recognition of the value of their work in the radio field. It was stated during the conference that there were approximately 70 000 amateur and experimental stations in the world, 50 000 of which were located in the United States of America.

#### **Television**

Allocations for Television services were made in the ultra-short wave band (i.e., below 10 metres). In Europe they cover 63 000 kc. and in America 114 000 kc. but in both cases the bands are largely shared with other possible services.

Whilst it was recognised that transmitters in the frequency range 30 Mc. (10 m.)–60 Mc. (5 m.) might on occasion set up long distance interference, the risk was not considered to justify any special precautions in their allocation.

#### **Radiosondage**

Radiosondage is the name given by the meteorological departments to the investigation of air currents in the upper atmosphere by means of small free balloons provided with a simple radiotelegraph transmitter, the automatic operation of which is controlled by the necessary measuring instruments (barometer, thermometer and hygrometer). The course of the balloon can be followed by means of a radio direction finder and so permits of the determination of the force and direction of the winds in the upper atmosphere when the sky is overcast and visual observations are impossible. This type of service has been considerably developed in both France and the U.S.A. during the last few years. The power of the balloon transmitter is small, about 1 watt, and interference is therefore a serious problem. Freedom from atmospheric interference can be secured by the use of ultra-short waves, while freedom from interference by other services requires the allocation of exclusive frequency bands to the balloon transmitters. The service is expensive since the balloon with its transmitter is often not recovered.

Three bands have been allocated to radiosondage :

- (1) 2 050–2 070 kc. (146.3–144.9 m.), in Europe only—exclusive allocation ;
- (2) 27.5–28 Mc. (10.91–10.71 m.). The allocation is exclusive everywhere except in the American continent, where it is shared with fixed and mobile services ;
- (3) 94.5–95.5 Mc. (3.175–3.141 m.), in Europe only—exclusive allocation.

It is planned to have 60 meteorological stations in Europe equipped for radiosondage investigations. In addition to the investigations so far made in France and in America, radiosondage measurements have been made in Greenland and in the Sahara, and also from a ship in the North Atlantic.

#### **Police Service**

Despite the increasing use of radio communication for the detection of crime and the pursuit of criminals, the service remains national in character and no international allocation has been made. Nevertheless, the increasing co-ordination between the police forces of European countries in particular is reflected in the

reservation of four specific waves to this service, viz. : 834. kc. (3 597 m.), 3 590 kc. (85.96 m.), 4 165 kc. (72.03 m.) and 6 792 kc. (44.17 m.).

#### **Special Meteorological and Time Services**

No change in the frequency allocations of these services was made at Cairo, those assigned at Madrid having proved satisfactory.

#### **Conclusion**

Some indication of the difficulty and delicacy of the negotiations involved in adjusting the Regulations to meet the pressure of new needs is given by the fact that the Technical Committee, together with its sub-committee, held no less than 95 meetings. That a large measure of agreement was found possible, as is implied in the foregoing résumé, constitutes no mean tribute to the patience, consideration and spirit of concession displayed by the representatives of the many administrations, each of which had its own special interests to safeguard.

---

## **BRONZE MEDAL AWARDED TO THE SHANGHAI TELEPHONE COMPANY**

**T**HE Shanghai Telephone Company in March, 1938, was awarded the Bronze Medal of the French Concession, Shanghai, in recognition of services rendered during the Sino-Japanese hostilities in 1937. The citation stated that the Company, under all conditions, had maintained a satisfactory telephone service and spontaneously organised from the outbreak of hostilities special liaison between the principal administrative and military organisations of the French and International Concessions, resulting in highly appreciated co-ordination between the various commands.

Notification of the award was communicated by the French Consul General, Shanghai, on behalf of the Municipal Council of the French Concession.



# A Working Standard for Telephone Transmission

By L. C. POCOCK, M.Sc.,

*Standard Telephones and Cables, Ltd., London, England*

IT will be recalled, by those who followed the development of the Transmission Reference System in the early days of the

quality system can be produced, and the need for such a system as a standard.

The carbon transmitter circuit, till now in use, is described in C.C.I.F. documents and is known as the working standard circuit, with carbon transmitter, or, more briefly, by the initials of the French title as the S.E.T.A.C.; it is also known as the Standard Test Circuit.

This system has given valuable service for many years, and is still a simple and useful system, but it has serious drawbacks; in particular, the type of carbon transmitter used suffers from the following disadvantages:

- (1) It is in use as an actual commercial telephone instrument in very few countries, and is fast disappearing;
- (2) It is less stable than many modern types of transmitter;

C.C.I.F., that it was at first contemplated that a number of secondary reference systems would be developed, less costly than the master reference system. After a time, this idea was dropped because it was not then feasible to produce high quality stable systems at low cost, and the sphere of usefulness of such systems seemed very limited if they were not in fact working standards.

The developments of the last decade, however, have changed the situation both with regard to the cost at which a reliable high

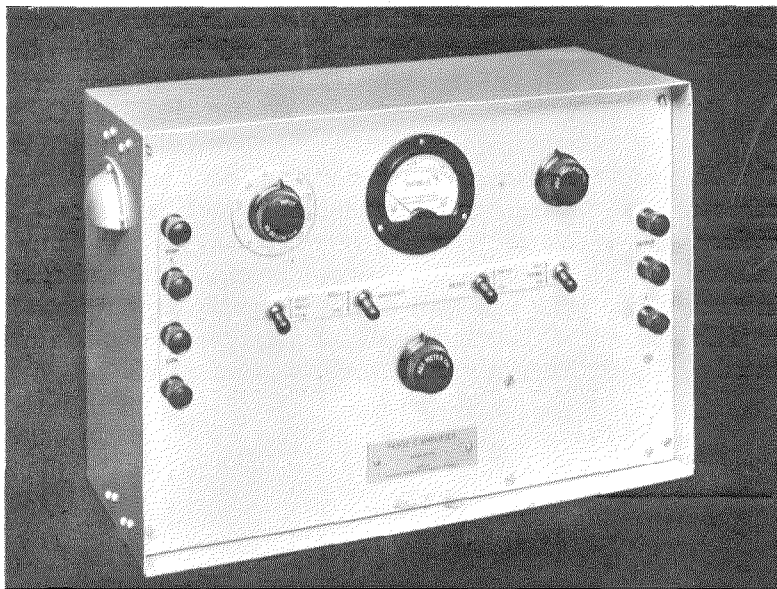

*Fig. 1—Amplifier.*

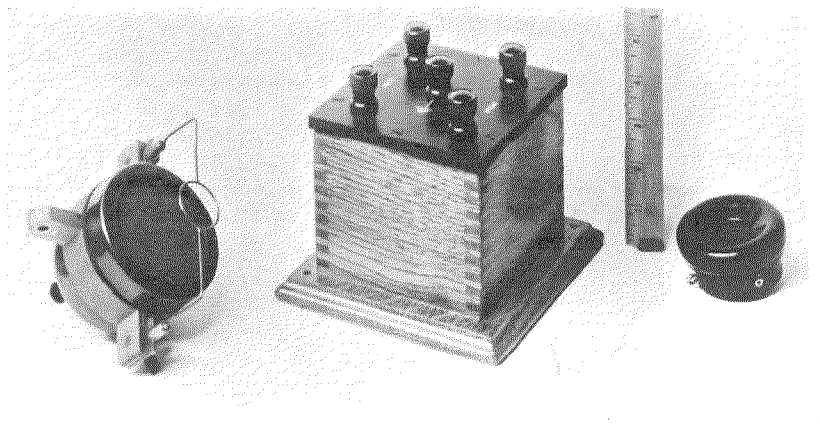

*Fig. 2—Transmitter, Receiver (Working Standards) and Transformer.*

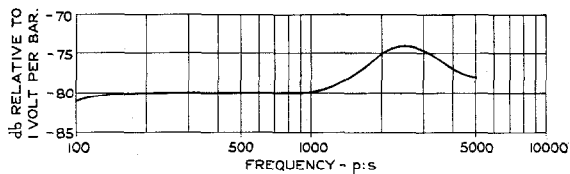

Fig. 3—Typical Transmitter Frequency Characteristic.

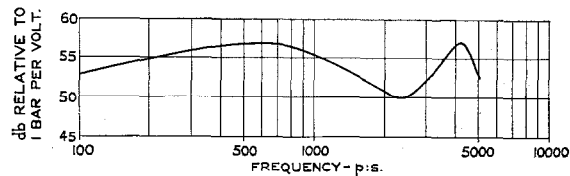

Fig. 4—Receiver Frequency Characteristic Measured on an Artificial Ear.

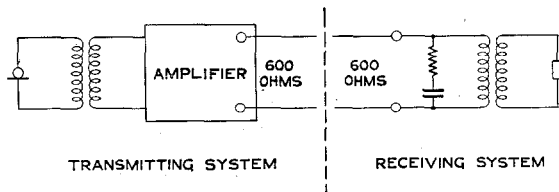

Fig. 5—Schematic of Complete Working Standard System.

- (3) On account of its relatively complex construction, the frequency characteristics of different transmitters of the same type vary widely ;
- (4) It has a frequency characteristic which represents performance distinctly worse than almost any modern commercial transmitter ;
- (5) It has considerable amplitude distortion ;
- (6) As a standard it requires periodic calibration and this can only be done by elaborate voice-ear tests ; for calibration, standards have to be sent to the C.C.I.F. Laboratory in Paris, or to the Laboratories of Standard Telephones and Cables, Ltd., in London.<sup>1</sup>

It is evident that there is ample justification for establishing a new working standard transmitter which is reliable, easy to calibrate and better in performance than modern commercial apparatus.

Recent developments in receiver design improve the

performance of the latest types of receiver about as much as the improvements that have taken place in transmitters, and it is therefore desirable to replace the old hand receiver standard by an instrument with better frequency characteristics.

The working standard, herein described, is illustrated in Figs. 1 and 2 ; it is a relatively high quality system of stable character. Having once been calibrated against a Transmission Reference System, it may thereafter be in-

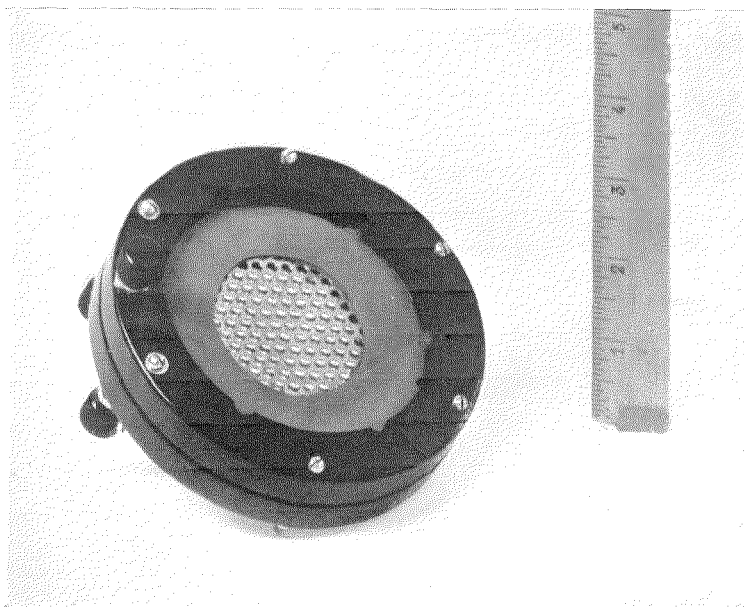

Fig. 6—Coupler.

<sup>1</sup> The Standard Telephones and Cables, Ltd. Laboratories in London have for the last 17 years maintained a service of calibrating standards for International System Companies and for Telephone Companies all over the world.

definitely maintained by a checking process which can be carried out in any telephone laboratory.

### The Transmitter

The transmitter is a permanent magnet moving coil instrument of a type already well established and widely used in broadcasting and public address work. It is provided with a moisture-proof screen to protect it from the breath when in continuous use for close-up speaking. It is adapted to mount on a stand in place of the former "solid back" standard and is fitted with a modal talking gauge.

Fig. 3 shows a typical frequency characteristic.

### The Receiver

The receiver is a permanent magnet moving coil instrument of small size; a frequency characteristic measured on an artificial ear is shown in Fig. 4.

### Complete System

The transmitting system has a reference equivalent approximately equal to that of the transmission reference system, and consists of the transmitter, a transformer (supplied separately from the amplifier for convenience in installing) and an amplifier.

The amplifier (Fig. 1) was designed primarily as a level meter, and has a frequency characteristic flat within 1 db or better over the range 1 000 to 5 000 p : s; it is provided with self-checking means of adjusting the gain and is used with a gain of 50 db.

The receiving system consists of a transformer and the moving coil receiver; the reference equivalent of the receiving system is approximately equal to the reference equivalent of the receiving system of the Transmission Reference System.

Fig. 5 shows in schematic form the complete working standard system.

### Calibration

The calibration for maintenance of the working standard is not absolute but relies on a voice-ear test of the transmitting and receiving systems against the Transmission Reference System; at the same time, comparative data are obtained on the transmitter and receiver which can be checked in any laboratory in order to ascertain whether these instruments have changed in performance and to provide a measure of any small change that may occur.

The calibration is discussed in an appendix. It may be briefly described as measuring the sum and difference of the efficiencies of two instruments, and so deducing the efficiency of each; or, more precisely, assigning at each frequency a number (in decibels) characterising the performance of the instrument.

The calibration is preferably carried out between two transmitters and between two receivers; but, if only one of each instrument is available, characteristic numbers which serve as a calibration may be obtained with a single transmitter and receiver.

The two instruments to be calibrated are coupled together, the overall loss being measured when current at various frequencies is supplied

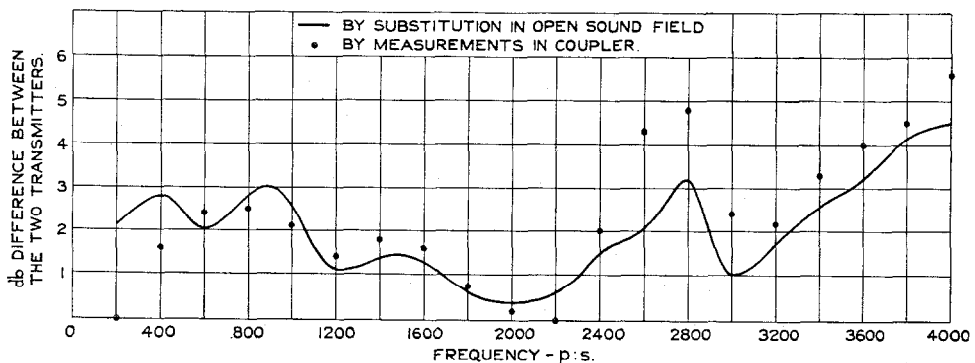

Fig. 7—Relative Efficiency of Two Transmitters.

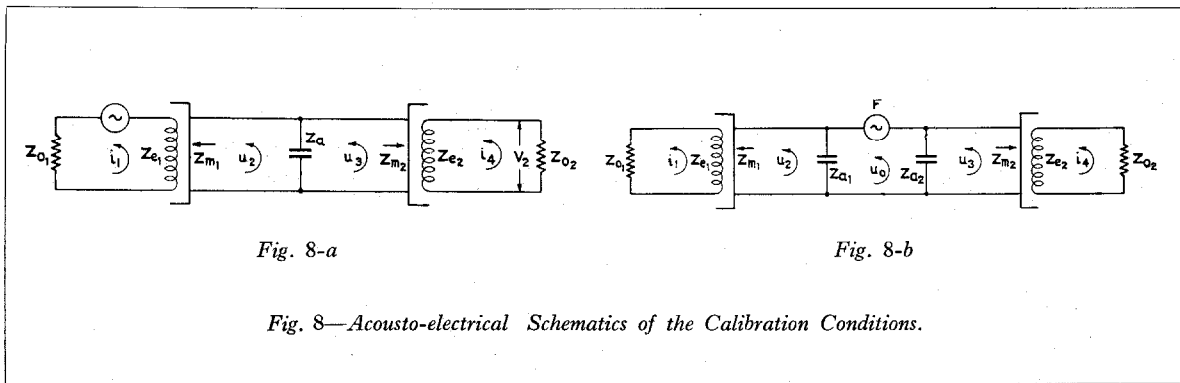

Fig. 8-a

Fig. 8-b

Fig. 8—Acousto-electrical Schematics of the Calibration Conditions.

to one instrument which drives the other acoustically. The overall loss is mainly dependent on the sum of the efficiencies of the two instruments.

The coupler (Fig. 6) contains a light foil membrane and appropriate grid electrodes by means of which the membrane may be electrostatically driven as a source of sound. When so excited the difference between the voltages at the terminals of the two instruments is substantially a measure of the difference in their efficiencies.

All the measurements required for the calibration are made by the amplifier of the system used as a level meter.

It is shown in the appendix that, if the two instruments tested together are similar, the results of the calibration yield a close approximation to the true difference in their frequency characteristics. Fig. 7 illustrates the relative efficiencies of two transmitters calibrated together by the coupler and also compared by a careful substitution test in the field of an artificial mouth. It will be noticed that the points denoting the efficiency of one transmitter relative to the other lie with a few exceptions well within 1 db of the results obtained by comparison in a free sound field.

As previously stated, the fundamental calibration is carried out by voice-ear comparison with the Transmission Reference System; the particular model herein described with one of its transmitters and receivers was found to have the following reference equivalents:

Transmitting end	..	+ 1.0 db
Receiving end	..	+ 1.0 db

### Impedances

The input and output terminal impedances of the amplifier are 600 ohms, and the input impedance of the receiving end is adjusted to 600 ohms by suitable networks neutralising the leakage reactance of the transformers, the networks being mounted in the box containing the transformer.

### Stability

It is unlikely that the transmitters and receivers will vary in performance appreciably so that experience probably will show that it is unnecessary to make very frequent calibrations. A simple means of calibration is, however, obviously necessary to ensure the maintenance of an accurate standard, particularly when a standard is suspected of giving incorrect results or after it has suffered accidental misuse.

Tests have been made of the effect of temperature. No measurable differences have been found between calibration figures obtained at 20° C. and 40° C.

### CONCLUSION

The equipment herein described is a reliable and simple standard for voice-ear telephone measurements, and is valuable for telephone laboratory applications where a high quality speech system is required or where sound pressure needs to be measured. The amplifier as a level meter has a range of 0 to 90 db below 1 mW (in 600 ohms). This wide range makes the instrument especially useful for measuring the frequency characteristics of transmitters and side tone characteristics of telephone sets. As a wide range voltmeter it also has numerous applications in the telephone laboratory.

## APPENDIX

Fig. 8-a shows the acousto-electrical schematic of the calibration conditions where acoustical impedances are to be regarded as equivalent mechanical impedances, and the electrical transformers are omitted.

The equations for the measurement of overall loss when one instrument drives the other are :

$$\left. \begin{aligned} i_1 Z_{e1} + u_2 M_1 &= V_1 \\ -i_1 M_1 + u_2 (Z_{m1} + Z_a) - u_3 Z_a &= O \\ -u_2 Z_a + u_3 (Z_{m2} + Z_a) - i_4 M_2 &= O \\ + u_3 M_2 + i_4 (Z_{e2} + Z_{o2}) &= O, \end{aligned} \right\} \quad (1)$$

where  $V_1$  equals the voltage at the terminals of the driving instrument;  $M_1$  and  $M_2$  are the force factors of the two transmitters (or receivers) and  $Z_a$  represents the parallel impedances  $Z_{a1}$  and  $Z_{a2}$ .

Solving for  $i_4$  and expanding the determinant of the denominator as the sum of complementary minors one obtains :

$$i_4 = \frac{V_1 M_1 M_2 Z_a}{\begin{vmatrix} Z_{e1} & M_1 \\ -M_1 (Z_{m1} + Z_a) & \end{vmatrix} \times \begin{vmatrix} (Z_{m2} + Z_a) & -M_2 \\ M_2 & (Z_{e2} + Z_{o2}) \end{vmatrix} - Z_a^2 Z_{e1} (Z_{e2} + Z_{o2})} \quad (2)$$

Appropriate tests have shown that the motional reactions are negligible, and therefore  $M$  may be neglected in the denominator and the measured loss is given by the logarithm of :

$$\frac{V_2}{V_1} = \frac{i_4 Z_{o2}}{V_1} = \frac{M_1 M_2 Z_a Z_{o2}}{Z_{e1} (Z_{e2} + Z_{o2}) \{(Z_{m1} + Z_a) (Z_{m2} + Z_a) - Z_a^2\}} \quad (3)$$

For the measurement made when electrostatically exciting the membrane in the coupler, the schematic of Fig. 8-b applies and the equations are :

$$\left. \begin{aligned} i_1 (Z_{e1} + Z_{o1}) + u_2 M_1 &= O \\ -i_1 M_1 + u_2 (Z_{m1} + Z_{a1}) - u_o Z_{a1} &= O \\ -u_2 Z_{a1} + u_o (Z_{a1} + Z_{a2}) - u_3 Z_{a2} &= F \\ -u_o Z_{a2} + u_3 (Z_{m2} + Z_{a2}) - i_4 M_2 &= O \\ u_3 M_2 + i_4 (Z_{e2} + Z_{o2}) &= O \end{aligned} \right\} \quad (4)$$

Whence, if  $V_a$  and  $V_b$  are the voltages measured across  $Z_{o1}$  and  $Z_{o2}$ , respectively, their difference in db is obtained from the logarithm of :

$$\frac{V_a}{V_b} = \frac{i_1 Z_{o1}}{i_4 Z_{o2}} = \frac{\begin{vmatrix} M_1 & O \\ (Z_{m1} + Z_{a1}) & -Z_{a1} \end{vmatrix} \times \begin{vmatrix} (Z_{m2} + Z_{a2}) & -M_2 \\ M_2 & (Z_{e2} + Z_{o2}) \end{vmatrix} Z_{o1}}{\begin{vmatrix} M_2 & O \\ (Z_{m2} + Z_{a2}) & -Z_{a2} \end{vmatrix} \times \begin{vmatrix} (Z_{m1} + Z_{a1}) & -M_1 \\ M_1 & (Z_{e1} + Z_{o1}) \end{vmatrix} Z_{o2}}; \quad (5)$$

and, neglecting  $M$  as before in the denominator :

$$\frac{V_a}{V_b} = \frac{M_1 Z_{a1} (Z_{m2} + Z_{a2}) (Z_{e2} + Z_{o2}) Z_{o1}}{M_2 Z_{a2} (Z_{m1} + Z_{a1}) (Z_{e1} + Z_{o1}) Z_{o2}}, \quad (6)$$

where  $Z_{o1}$  is made equal to  $Z_{o2}$ .

When two similar instruments are compared  $Z_{a1}/Z_{a2}$  by the symmetry of the structure is as nearly as possible 1, and is independent of frequency.  $Z_{e2}/Z_{e1}$  is substantially constant. Hence (6) may be written with  $K_a$  a constant.

$$\frac{V_a}{V_b} = \frac{M_1}{M_2} \frac{Z_{m2} + Z_{a2}}{Z_{m1} + Z_{a1}} K_a; \quad (7)$$

and (3) may be written with a constant  $K_b$  (neglecting the small variation of  $Z_{e1}$  with frequency):

$$\frac{V_2}{V_1} = \frac{M_1 M_2 Z_a}{(Z_{m1} + Z_a)(Z_{m2} + Z_a) - Z_a^2} K_b. \quad (8)$$

If  $Z_a$  and its components  $Z_{a1}$ ,  $Z_{a2}$  were small compared with  $Z_m$ , combination of (7) and (8) would lead to:

$$\sqrt{\frac{V_a}{V_b} \cdot \frac{V_2}{V_1}} = \frac{M_1}{Z_{m1}} \sqrt{Z_a}, \quad \sqrt{\frac{V_b}{V_a} \cdot \frac{V_2}{V_1}} = \frac{M_2}{Z_{m2}} \sqrt{Z_a}. \quad (9)$$

These expressions are recognisable as giving the relation between voltage and diaphragm pressure in a transmitter or receiver.

Taking into consideration the wide frequency range concerned and other limitations, it is not practicable to make  $Z_a$  always small compared with  $Z_m$ ; for the case of  $Z_a$  large compared with  $Z_m$ , expressions similar to (9) are:

$$\sqrt{\frac{V_a}{V_b} \cdot \frac{V_2}{V_1}} = \frac{M_1}{\sqrt{Z_{m1} + Z_{m2}}}, \quad \sqrt{\frac{V_b}{V_a} \cdot \frac{V_2}{V_1}} = \frac{M_2}{\sqrt{Z_{m1} + Z_{m2}}}. \quad (9a)$$

Thus, in both cases and of course in intermediate cases, there are obtained numbers which depend upon the force factor and which will be significantly (though differently) changed if a change occurs in the value of the mechanical impedance of the diaphragm.

Measurements indicate that at 1 000 p : s  $Z_a$  has the same order of impedance as  $Z_m$  for the transmitter as well as for the receiver. Since  $Z_m$  must be fairly constant for the transmitter,  $Z_a/Z_m$  will be less than unity at higher frequencies. The receiver impedance  $Z_m$  is approximately inversely proportional to the frequency, as also is  $Z_a$ , so that the ratio remains approximately constant.

Now it is very unlikely that  $Z_m$  will change except as the result of an accident seriously damaging the instrument; and, further, any change in an element on which  $Z_m$  depends would provoke relatively large changes in  $Z_m$  at some part of the frequency range. Such changes would affect the frequency response and thus appear in the characteristic calibration numbers.

The calibration numbers depend directly upon the force factor and so, if there should be a small change in performance (for example due to weakening of the flux), the necessary correction for each instrument can be found.

# L.M.T. Laboratories 7-frequency Radio-printer

By L. DEVAUX and F. SMETS,

*Les Laboratoires, Le Matériel Téléphonique, Paris, France*

IN printing telegraph systems for wire communication it is universal practice to translate the character to be transmitted into a telegraph code signal consisting of a combination of (usually five) "marking" or "spacing" elements of equal duration, and at the receiving end to re-translate the code signal into the original character. Such systems are not well adapted to radio communication, since the effect of superimposed atmospherics or other interference is to modify the received code signal which is then necessarily translated by the receiving mechanism into some character other than that originally transmitted. Experience has shown that, up to the present time, it has not been possible to overcome this difficulty except by using an elaborate extra equipment, as in the case of the Baudot-Verdan system.

An alternative method of sending printed messages consists in "scanning" or analysing each printed character into a number of elementary lines and transmitting these elementary lines in the form of dashes and spaces of varying length; at the receiving end the reproduced lines build up the original character. Such a system of transmission is not unlike the facsimile method. It is well suited to radio circuits since interference cannot change a letter into another one which is totally dissimilar, the only effect being to print small extra elements or to suppress small elements of the transmitted letters; and, as is well known, a considerable amount of such "bad printing" does not materially depreciate the intelligibility of printed text. The characters will be more or less accurately reproduced, depending upon the strength of the interfering static, but no "printing error" is possible. Moreover, the operator is constantly aware of the quality of transmission, independently of whether the messages are in code, plain language or cypher, and may request a repetition whenever necessary.

In the radio-printer system developed in the L.M.T. Laboratories, and described below, the characters are scanned or analysed in seven horizontal lines, each horizontal line being represented in the electrical transmission by one definite audio-frequency. The lines are transmitted simultaneously rather than in sequence and the radio carrier is, therefore, modulated simultaneously by all the audio frequencies corresponding to the lines. This arrangement enables a high speed of letter printing to be obtained, combined with slow modulation of the audio frequencies which carry the scanning and, hence, with long operating periods for the printing relays and a resultant high degree of reliability in printing.

The equipment operates on the "start-stop" principle, i.e., the receiver mechanism is automatically set in motion at the beginning of each character-transmission and automatically arrested when the character has been completed. There is, therefore, no need to maintain synchronism between the transmitting and receiving mechanisms, and the receiver may in fact be left unattended.

In the signal modulation of the individual audio frequencies the "marking" or printing condition may correspond either to the existence or to the suppression of these frequencies. The latter condition has been adopted for reasons which are discussed later. The general effect of static in this case is, therefore, not to print unwanted components of letters, but to suppress points in the characters, which in the majority of cases remain perfectly legible.

## **DESCRIPTION OF THE RADIO-PRINTER**

It is convenient to divide the description into two parts:

- (a) Mechanical and electro-mechanical devices, including the scanning, the translation of both keyboard and perforated tape

operations into electrical impulses, the storing of characters, the modulation of the frequencies, the receiving relays and the mechanical printer.

- (b) Electrical circuits, supply of frequencies, filtering of received signals and operation of the receiver.

**a.1 Scanning**

Although all conventional characters can be scanned in five lines if necessary, scanning in seven lines gives much better analysis, and has, therefore, been adopted (Fig. 1). All characters, including letters, figures and punctuation marks, have been drawn so that they may be built up from a number of elementary lines, assembled according to requirements. The total number of characters provided amounts to 46, built up from the 39 elementary lines shown on Fig. 2.

It is to be remarked that some elementary lines may be obtained by the combination of two other lines; for example, line 16 is made by addition of lines 2 and 7, etc. The total number of elementary lines can thus be reduced to 23.

**a.2 Transmission**

The transmitter is equipped with seven low-frequency oscillators working continuously and modulating the radio transmitter. The mechanical problem of transmission consists in controlling these oscillators in the proper time and sequence so as to suppress momentarily the modulation as required.

Advantage has been taken of the great facilities afforded by standard telephone relays to reduce to a minimum the number of mechanical parts. A system based on the use of such relays has been designed for making nearly all the requisite contacts, and provides for either keyboard or tape transmission, and for the storing of signals, a feature which improves greatly the efficiency of manual operation.

The primary elementary lines are generated by a set of 23 cams, carried by a continuously rotating shaft, and fitted with contact springs. Combinations of primary lines can be obtained by means of contacts in parallel. A few of these elementary line cams are shown on Fig. 3, bearing their own number taken from Fig. 2.

To each character requiring seven lines corresponds a relay bearing eight contacts. Seven of these contacts are used to connect the seven oscillators to the proper cams, while the eighth closes a circuit locking the relay. A few characters such as dash, full stop, comma, etc., which require less than seven lines, are provided with relays bearing a smaller number of contacts. There are 46 character relays, but only a few

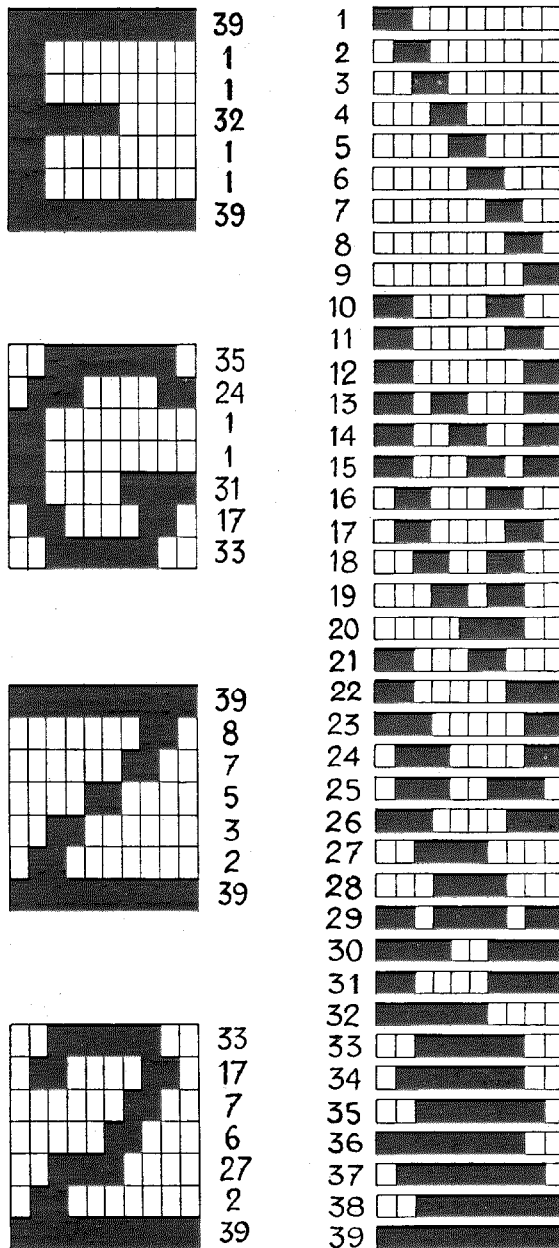

Fig. 1—Scanned Characters. Fig. 2—Elementary Bands



are shown on Fig. 3 (lower part, right hand). They connect the seven oscillators, 1 to 7, which modulate the carrier, to the cam contacts, so that an oscillator is made inoperative when the cam contact to which it is connected is closed.

The common return circuit for all character relays is made through a common start-sending relay SR, which is intended to send first the start signal when any character relay is operated. The start signal consists in the momentary suppression of the frequencies corresponding to lines 1, 3, 5 and 7, and is obtained by means of the two starting cams CSC which operate their contacts just before the primary line cams begin to work. Thus the start signal will be sent only if the start-sending relay SR is energised, i.e., if a character relay is operated.

Character transmission consists, therefore, in the operation of a character relay at the proper moment, just before the starting cam closes its contacts, and keeping the relay energised until the lines are fully transmitted. This latter condition is easily satisfied by means of the locking contacts on the character relays, the common circuit of which is controlled by a cam LC which operates its contact at the appropriate time during the revolution of the shaft.

### **a.3 Perforated Tape Operation**

The transmitter has been designed to use a standard perforated tape, according to the five-unit code and giving simultaneous contacts for each row of perforations. The Murray transmitter is particularly suitable, and is schematically indicated on Fig. 3 (upper right part).

The translation of the five-unit code is made as follows :

The contacts of six relays CR1, CR2 . . . , CR6 are connected to form chain circuits as shown on Fig. 3. In practice, standard telephone type relays with only eight contacts have been used throughout, connected in multiple for CR4, CR5 and CR6. The first chain relay CR1 discriminates between letters and figures, and, when in the position shown on Fig. 3, only letter relays may be energised. The other five relays, CR2 to CR6, are connected to the five contacts of the tape transmitter, through a switch TKS which is set by hand for tape or keyboard operation as desired. A cam TMC, fitted on the same shaft as the line cams, operates

the tape transmitter in proper synchronism.

Each combination of perforations in the tape operates the corresponding combination of the chain relays, and results in the operation of the corresponding character relay.

When the code combination for changing over from letters to figures occurs, the contacts of the chain relays operate relay LFR which first causes chain relay CR1 to become and remain energised. The upper set of character relays are now operated, and figures or punctuation signs are sent. To come back to letters, the code combination operates the relay FLR and CR1 is released and returns to the "letter" position.

### **a.4 Keyboard Operation**

Keyboard operation has been slightly complicated, but largely improved, by adding a storing register between the keyboard and the chain relays. This completely does away with the necessity of operating the keyboard at the (constant) speed of the cam shaft. The operator can thus depress the keys at any moment, in any sequence, and the speed of actual transmission is nevertheless constant and equal to the mean value of the speed of manual operation.

The keyboard is shown in schematic form at K, Fig. 3, a few keys only being drawn. A six-unit code is used here because the first chain relay CR1 (letters-figures) is operated directly by one of the contacts of each key. This does away with special keys for shifting from letters to figures, or vice versa, and simplifies the operation. The keys give the code combination by closing a variable number of contacts with the common contact bars B1 to B6.

### **a.5 Storing Register**

The principle of this device is as follows : A number of groups of six relays (corresponding to the six contact bars) is provided. Each group, when connected to the contact bars, is able to register the combination of six units given by the depression of a key. The same group, if connected later to the chain relays, will transmit to these relays the registered combination. These connections to contact bars and to chain relays are made by two rotating switches, the incoming switch IRS connecting the bars to the register relays, and the outgoing

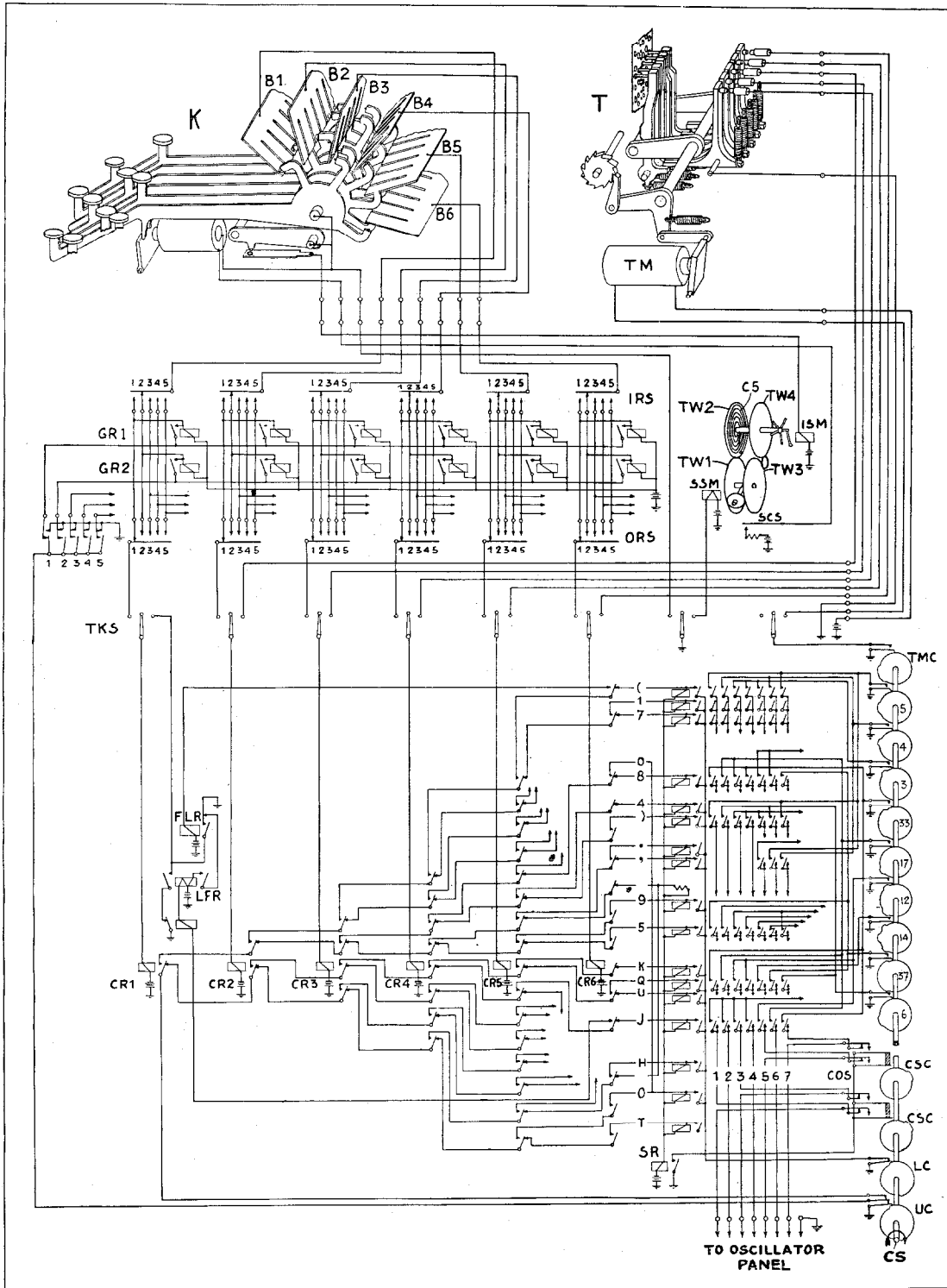

Fig. 3—Schematic of the Transmitter.

rotating switch ORS connecting the register relays to the chain relays. As many groups of six relays may be provided as are found advisable. In practice, five groups are sufficient to give satisfactory operation. Fig. 3 shows only two groups of these relays, GR1 and GR2.

The incoming and outgoing switches always run one after the other, but the second is at least one position behind the first. The incoming switch is advanced by one step every time any key is depressed, but the outgoing switch is advanced by one step at each revolution of the cam shaft. Consequently, if many keys are depressed in very rapid sequence, the incoming switch rotates rapidly forward, while the outgoing switch advances regularly by one step at each revolution of the cam shaft until it catches up one step behind the incoming switch. Since

five groups of register relays have been provided, there must not be more than four steps difference between the two switches. For this purpose, a differential device closes the circuit of a magnet which locks the keys, so that they cannot be operated until the steady advance of the outgoing switch has made free at least one group of register relays. A schematic representation of the device will be found in Fig. 3.

#### a.6 Receiving Mechanism

The receiving mechanism is shown in schematic and simplified form on Fig. 4. At the receiving end, the voice frequency currents, after selection by filters, are fed to the printing magnets PM1 to PM7. Each magnet is used to press one of the seven adjacent levers PL, which each carry a printing stylus PS lying on the

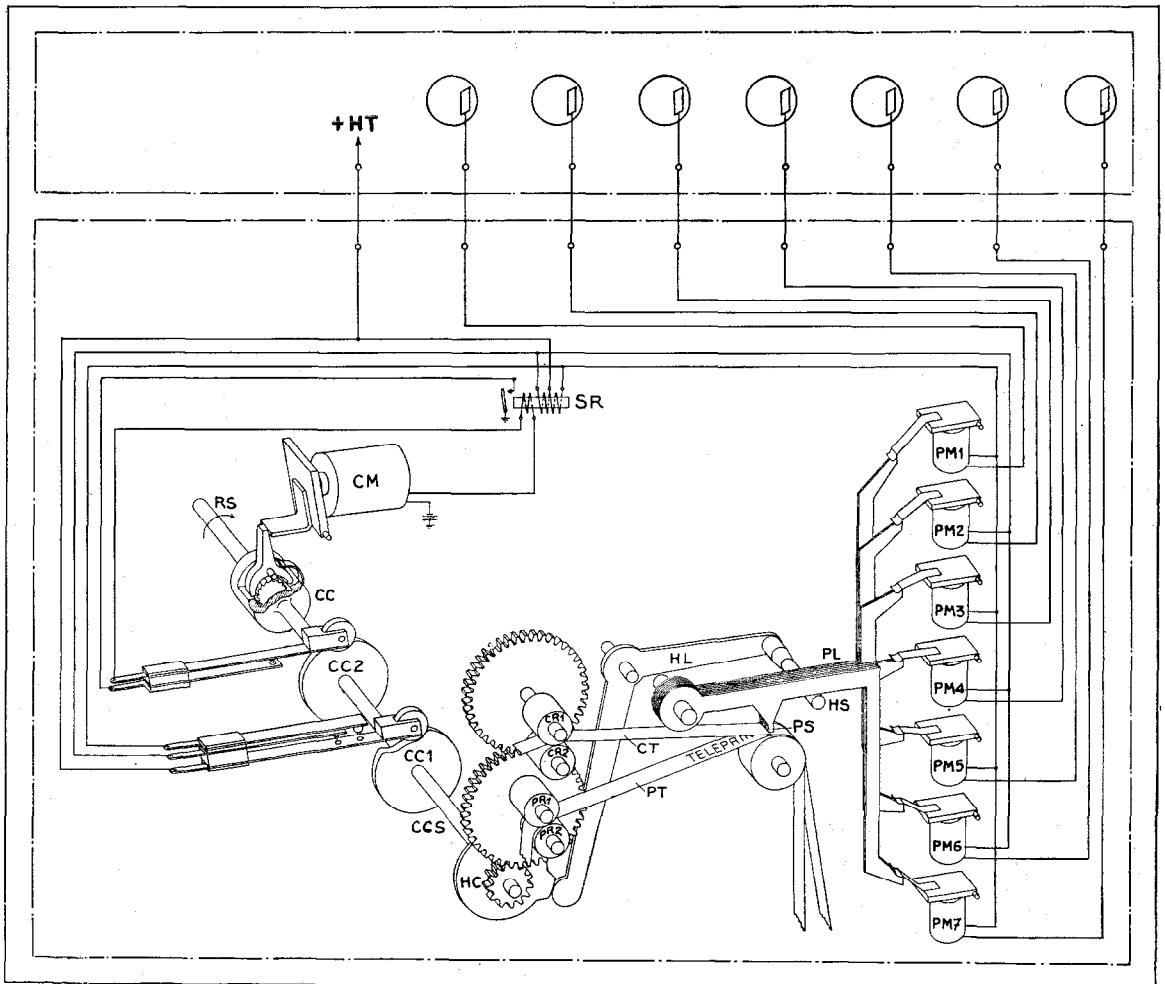

Fig. 4—Schematic of the Receiver.

running paper tape PT, a carbon paper tape CT being inserted between paper and styli. Dots and dashes are thus printed on the paper tape, according to the currents received by the magnets, and their assembly builds up the transmitter characters.

The paper and carbon tapes are moved by two pairs of rollers, which are driven by a shaft CCS. A constant speed motor drives another shaft RS and a clutch CC, of the type used in the Creed Teleprinter, gives to the shaft CCS an intermittent motion through the action of the magnet CM, which is energised by the start relay SR.

The start relay carries two opposed windings, the first being connected in the common high voltage return of printing magnets 1, 3, 5 and 7, while the second is similarly connected to printing magnets 2, 4 and 6. The reason for this is the following: strong static, which would be liable to operate the start relay, has a wide and continuous frequency spectrum, and its action in the seven channels is nearly uniform; since the currents delivered to the printing magnets act differentially on the starting relay, this does not operate, and false starts are avoided.

A study of Fig. 4 will show how the shaft CCS makes only one revolution for each clutching operation, and how a stud HS prevents the printing styli from pressing the paper at the instant of start, while printing is possible during the remainder of the shaft revolution.

The speed of the motor driving the shaft does not need to be very accurately governed, the only result of variations in the speed being very slight variations in the width of the printed characters.

### b.1 Modulation of the Voice Frequencies

It has already been mentioned that the "mark" signal may consist either in the existence or in the suppression of the voice frequency current. As the printer is intended to work on radio links which are subject to selective fading, it is necessary to provide individual automatic

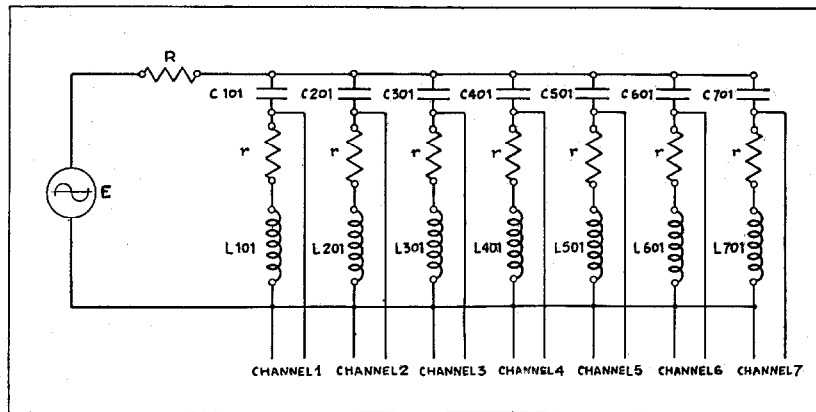

Fig. 5—Schematic Diagram of Filter Arrangement.

volume control, at the receiving end, for each voice frequency. This is the main reason why the signals have been "marked" by the suppression of the appropriate voice frequency current. This method, moreover, has the advantage that static will generally result in the suppression of a few points in the characters, instead of printing extra dots.

### b.2 Voice Frequencies and Filters

The choice of the voice frequencies is determined:

- (i) By the speed of transmission and the quality of the filter at the receiving end;
- (ii) By the frequency band which is generally passed by telephone links.

The printer has been designed for a speed of 5 characters per second (50 words per minute) and, consequently, owing to the analysis of characters, the shortest signals last 20 milliseconds. This corresponds to a fundamental frequency of 25 p : s. Good transmission requires that the third harmonic of this fundamental frequency should be passed, and the pass-band of the receiving filters should therefore be 150 p : s.

For economic reasons, it is desirable to use filters comprising only one coil and one condenser, and the  $Q$  factor of this circuit must be neither too high, for the sake of quality, nor too low, for the sake of selectivity. Experience has shown that a frequency spacing of 240 p : s gives a good compromise, together with a value of  $Q = 10$  for the tuned circuits.

The frequencies adopted are odd multiples of 120 p : s, starting with 600 p : s, namely, 600,

840, 1 080, 1 320, 1 560, 1 800 and 2 040 p : s. The only harmonic relationship between these numbers is that the sixth is the third harmonic of the first. This fact is important as it avoids the printing of wrong dots owing to harmonic distortion in the radio-telephone link. The total frequency range required for this radio-printer service extends roughly from 500 to 2 200 p : s.

Fig. 5 shows the arrangement of the tuned circuits ; Fig. 6 gives the transmission characteristic of a filter (4th channel, 1 320 p : s).

Around the resonant point of one of the circuits  $C, L, r$ , the shunting effects of the other circuits in parallel is negligible and the voltage  $V$  developed across the circuit is equal to

$$V = E Q = E \frac{\omega L}{R+r}$$

As  $Q$  is made constant for all the circuits,

their efficiency is the same. For the other frequencies, the circuit  $C, L, r$ , under consideration, is shunted by a resistance  $r$ . This resistance is made as small as possible, and is the smallest among the effective resistances of the coils. The total resistance  $R+r$  is chosen great enough to give the desired pass-band : a convenient value was found to be 560 ohms, corresponding to  $Q = 10$ . The dotted curve of Fig. 6 represents the value of the ratio  $\frac{V}{E}$  for one single tuned circuit of  $Q = 10$ . The full line curve represents the same ratio as obtained with the complete array of tuned circuits as shown on Fig. 5. Although the tuning is not sharp the interference from the neighbouring channels is quite small.

### b.3 Oscillators

The schematic diagram of the oscillator panel is represented on Fig. 7. It includes 7 inde-

pendent oscillators, an amplifier and the necessary testing equipment (represented by thin lines).

The oscillators are quite classical in design. The output network (R 102, R 103, R 104) is fed by a winding loosely coupled with the plate choke T 101. The resistances of the output network are chosen such that the output of any one oscillator is not appreciably altered by the operation of the signal modulating contacts of the others. In order to send out square shaped signals, the value of R 102 has been made large enough to keep the tube oscillating at constant amplitude during modulation. The value of R 104 is variable and allows the adjustment of the output of each oscillator. When the seven

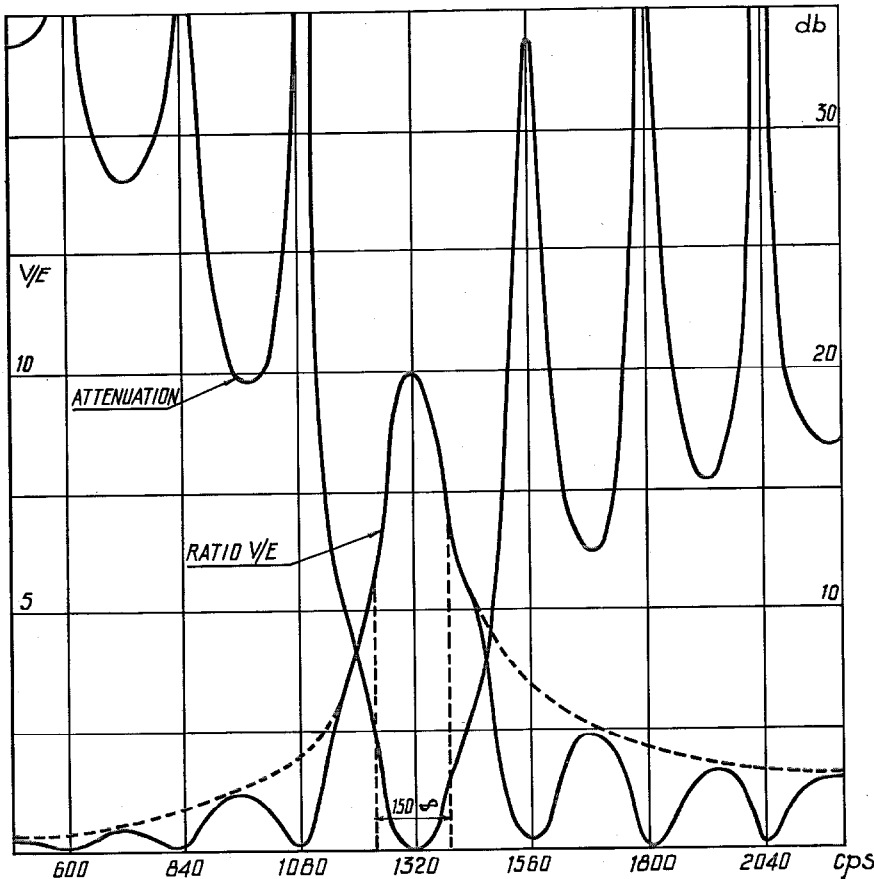

Fig. 6—Typical Filter Characteristic.

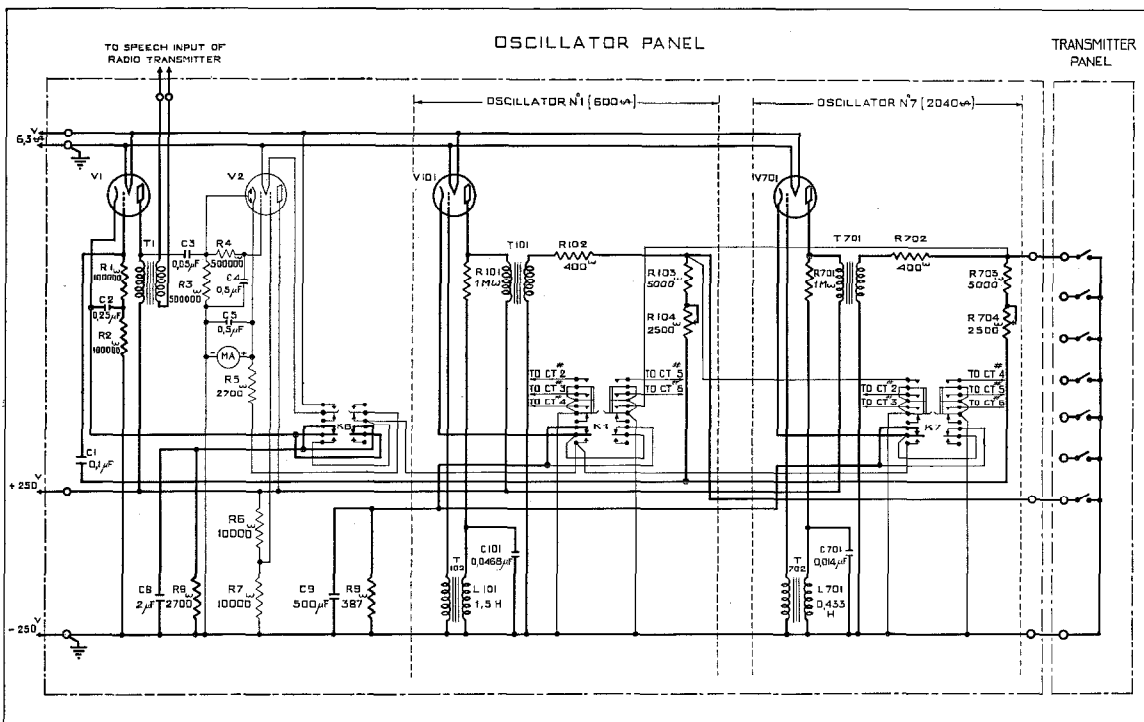

Fig. 7—Schematic Diagram of Oscillator Panel.

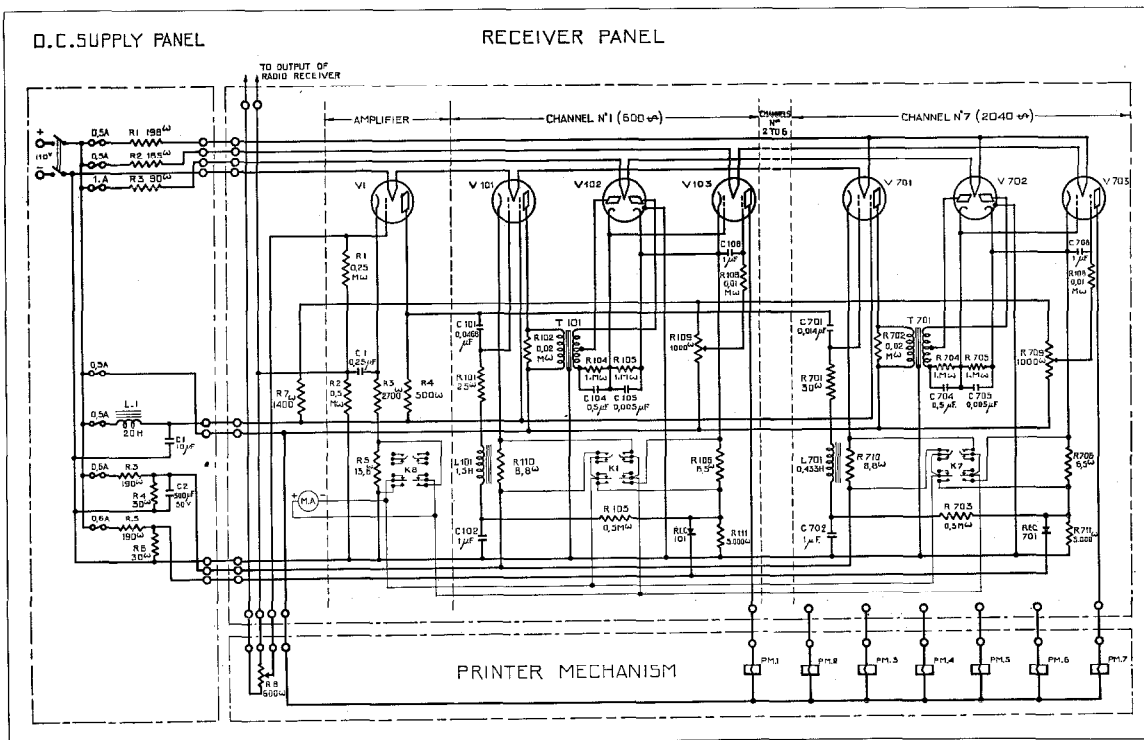

Fig. 8—Schematic Diagram of Receiver Panel.

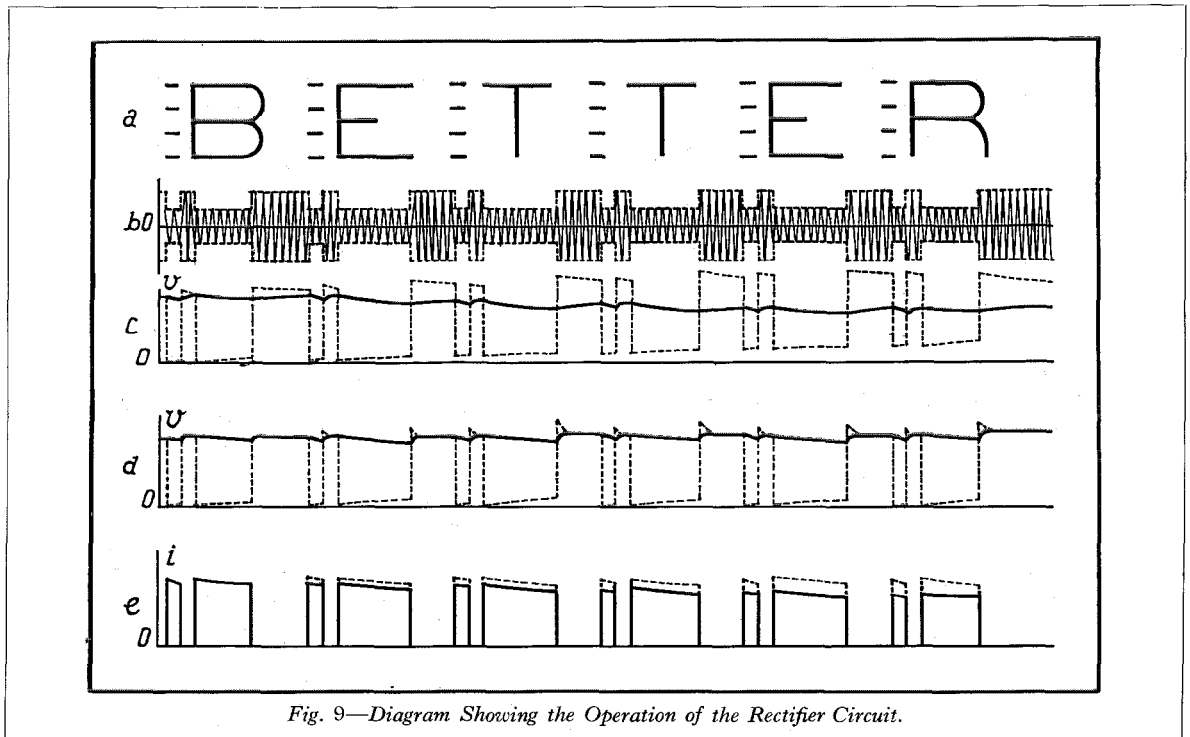

Fig. 9—Diagram Showing the Operation of the Rectifier Circuit.

frequencies are in simultaneous use, the output is approximately 5 mW into 600 ohms.

The keys K1 to K8 are provided for control purposes and enable the attendant either to measure the plate currents or to check the tone and measure the amplitude of each oscillator independently of the others.

#### b.4 Printer-receiver

On Fig. 8 is shown the schematic diagram of a printer-receiver specially designed for 110 volts D.C. supply.

The combined audio-frequency signals supplied by the *radio* receiver (not shown) are applied to the grid of the tube V 1, the plate

circuit of which is coupled by means of resistance R 4 to the filter arrangement. As R 4 is small compared with the resistance of the tube V 1, the damping of the filters is independent of the tube characteristics. The output of the filter is applied to 7 identical circuits, comprising each an amplifying tube (V 101) a rectifier (V 102) and an output tube (V 103).

The output of the amplifier tube V 101 is supplied through a transformer T 101 to a rectifying circuit comprising a double diode V 102, and two resistances R 104 and R 105, shunted by condensers C 104 and C 105. The time constant of the circuit R 104-C 104 is 0.5 second, while that of the circuit R 105-C 105 is 5

milliseconds. The common end of R 104 and R 105 is connected to the centre tap of the transformer secondary winding through the diode D 1 of V 102. If an unmodulated carrier is applied to the transformer, the voltage drops across the resistances R 104 and R 105 are practically equal. If the carrier is

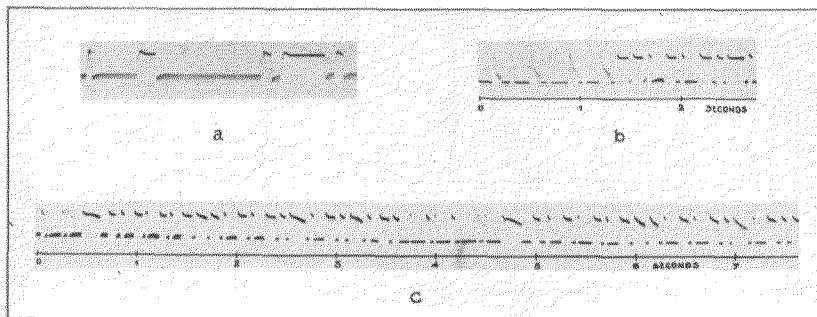

Fig. 10—Oscillograms of the Current in the Printer Magnets.

suppressed for a short time, corresponding to a signal, the voltage drop across R 105 becomes zero after a few milliseconds, while that across R 104 does not change appreciably.

If interference due to neighbouring channels or noise is present, and added to the carrier, the voltage drops in R 104 and R 105 are increased, but remain equal. If the level of interference is equal to that of the carrier, and if again the

carrier is suppressed for a short time, the voltage drop across R 105 will become zero, just as if no interference were present. In other words, condenser C 104 acts as a reservoir which will absorb interference up to a level which, since R 104 equals R 105, is equal to the signal level.

The suppression of the carrier thus causes the bias of the output tube to become zero, even in the presence of noise, and sets up a current

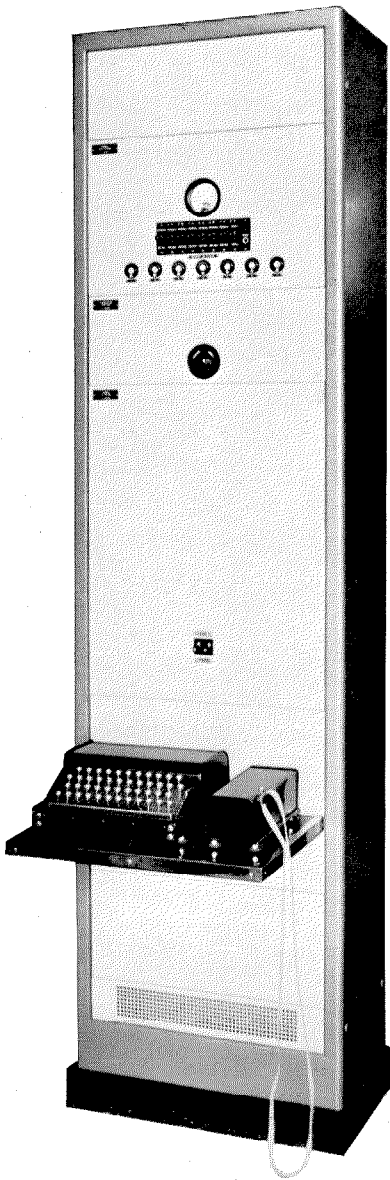

Fig. 11—Printer Transmitter Unit.

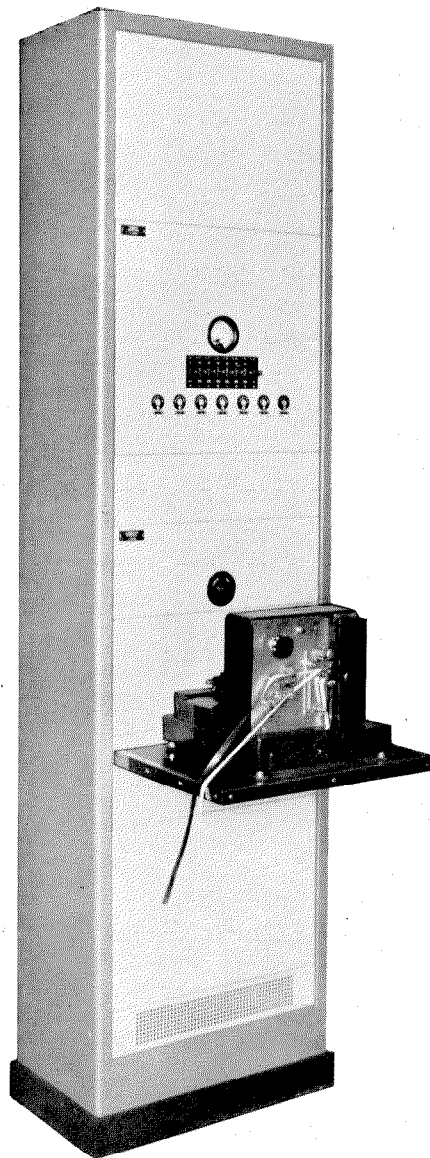

Fig. 12—Printer Receiver Unit.



impulse in the plate circuit and printing magnet. If the diode D1 were not connected, however, a sequence of signals would give weaker and weaker impulses. This will be more readily understood by considering, for example, the transmission of the upper line of the word "better," which is analysed in Fig. 9. The output of the filter is represented by diagram (b). The full line of diagram (c) represents the voltage across R 104, which decreases slowly from a value corresponding to the peak of the applied

voltage to a value corresponding to the mean of the applied voltage. The dotted line of (c) represents the voltage across R 105, which tends to become symmetrical with respect to that across R 104. The current through the printing magnet would then be represented by the full line of diagram (e). This drawback is removed by the use of diode D1, which allows condenser C 104 to charge very rapidly, while it discharges slowly through R 104. The voltages across R 104 and R 105 are then represented by the full

and dotted lines, respectively, of diagram (d), and the current in the printing magnet is represented by the dotted line of diagram (e). The "memory effect" of the circuit is thus removed.

The screen voltage of the output tube V 103 is supplied through a resistance R 108, shunted by a condenser 108. This arrangement has the effect of a kick-circuit on the printing magnet, as can be seen in oscillogram (a) of Fig. 10.

For good printing the operating current in the printer magnets must exceed 7 mA, and the non-operating current must be less than 3 mA. With no voltage drop in the resistance R 105, the output current of V 103 is set to 10 mA by means of the potentiometer R 109.

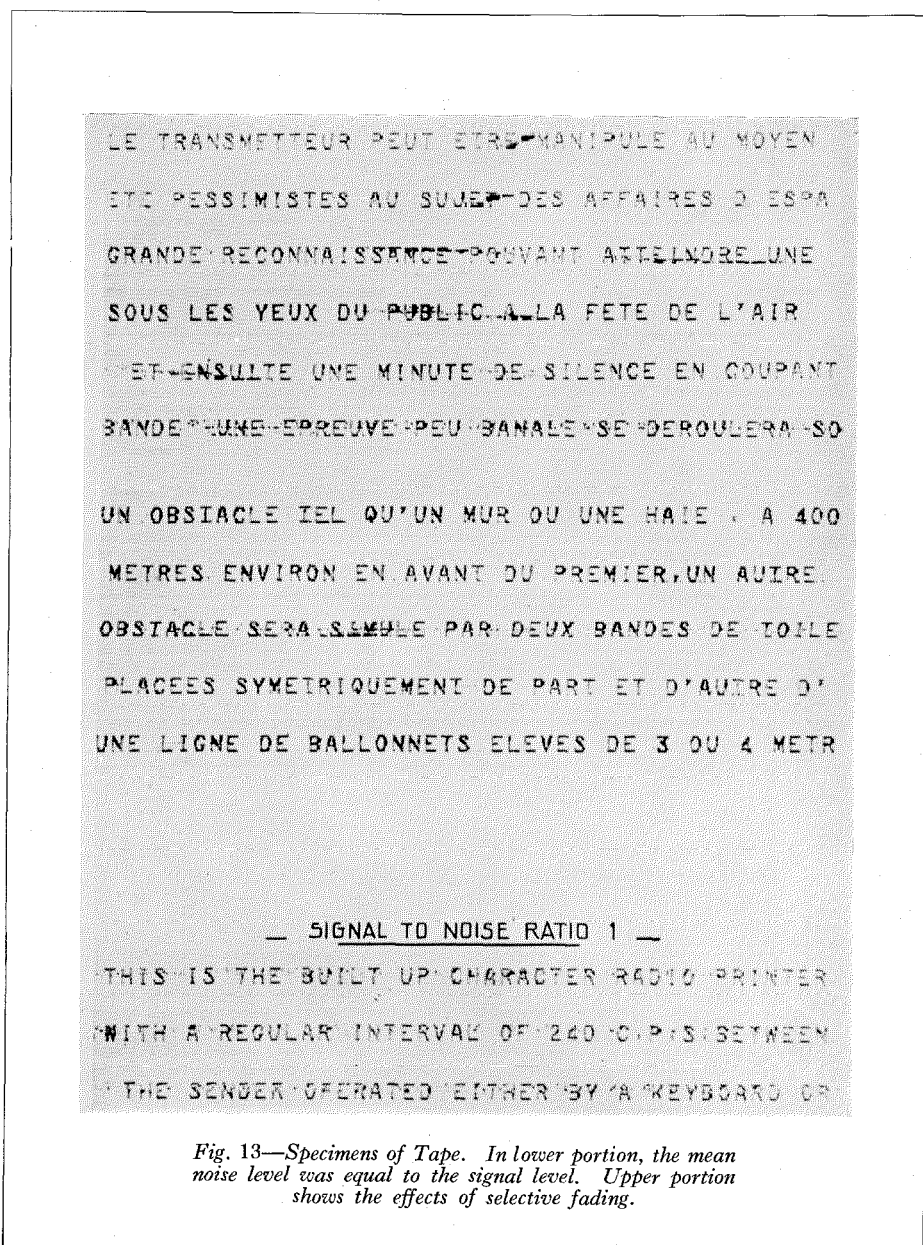

Fig. 13—Specimens of Tape. In lower portion, the mean noise level was equal to the signal level. Upper portion shows the effects of selective fading.

The ideal A.V.C. would be such as to keep the minimum current of V 103 constant, whatever be the V.F. input level. This case is approached by controlling the slope of the amplifying tube V 101 by the voltage across the resistance R 111, inserted in the cathode circuit of V 103. In order to make this voltage practically independent of the current pulses during printing, the resistance R 111 is shunted by a selenium rectifier R.E.C. 101 which is polarised by a voltage of 12 volts. The voltage across R 111 can thus never exceed 12 volts. Its mean value is practically proportional to the "spacing" current in the printing magnets, and can be used for

biassing the grid of the amplifier tube V 101. A smoothing circuit (R 103, C 103) with a time constant of 0.5 second is inserted between the resistance R 111 and the grid circuit of V 101.

Oscillograms (b) and (c) of Fig. 10 show the A.V.C. action of this circuit for rapid and slow fading, respectively. The range of level corresponding to these oscillograms is 20 db. The signal-to-noise ratio was kept constant and equal to unity.

JE PASSE DONC LA BANDE. UNE EPREUVE PEU  
 BANALE SE DEROULEA SOUS LES YEUX DU PUBLIC A  
 LA FETE DE L'AIR. LES SPECTATEURS DES FETES  
 AERIENNES ONT SOUVENT ASSISTE A DES EPREUVES  
 D'ACROBATIE. CETTE ANNEE, UNE COMPETITION  
 TRES ORIGINALE, ENTRE CINQ EQUIPAGES DE L'  
 ACTIVE ET CINQ EQUIPAGES DES RESERVES DE L'  
 ARMEE DE L'AIR SERA PRESENTEE AU PUBLIC.  
 LES APPAREILS SE POSERONT NORMALEMENT FACE  
 AU VENT, HELICE AU RALENTI ET SANS GLISSADE,  
 DE 200 METRES D'ALTITUDE. UNE BANDE DE TOILE  
 PERMETTRA AU PUBLIC D'IMAGINER UN OBSTACLE  
 TEL QU'UN MUR OU UNE HAIE. A 400 METRES  
 ENVIRON EN AVANT DU PREMIER, UN AUTRE OBSTACLE  
 SERA SIMULE PAR DEUX BANDES DE TOILE PLACEES  
 SYMETRIQUEMENT DE PART ET D'AUTRE D'UNE LIGNE  
 DE BALLONNETS ELEVES DE 3 OU 4 METRES AU  
 DESSUS DU TERRAIN. L'EQUIPAGE AYANT ATTERRI  
 SUR LA PLUS COURTE DISTANCE, AU PLUS PRES DE

Fig. 14—Typical Specimen of Tape as Normally Received in Paris from Algiers.

### PRACTICAL RESULTS

Figs. 11 and 12 show, respectively, the printer transmitter and receiver units, and need no special comments except that much smaller bays could have been used for housing the electrical equipment.

The apparatus was first tested in a radio-telephone link devoid of fading, but into which intentional noise could be introduced at will. Fig. 13 (lower part) shows the tape as received during these tests, the mean noise level being

the same as the signal level. Extra dots are numerous, due to saturation of the receiver during short periods of very high, instantaneous noise level, but the text is easily legible and devoid of wrong letters.

Another series of tests was carried out in July, 1937, using the radio-telephone link between Algiers and Paris, a distance of 800 miles, on a frequency of 12.2 megacycles. The transmitter was in Algiers and the receiver in Paris. This link has a good signal-to-noise ratio (more than 30 db) but is greatly subject to fading. Selective fading is severe and frequently reaches 20 db and more. Fig. 13 (upper part) shows the effect of selective fading, which results in a series of dashes which slowly cross the width of the characters, i.e., the band of

modulation. The printer was in daily use for nearly a month, and the results were very satisfactory, both with perforated tape and with keyboard operation. Fig. 14 shows a typical specimen of the tape as normally received in Paris. In some instances of extremely bad transmission conditions, when a code printer would have been definitely useless, the radio-printer continued to deliver an intelligible test.

It will be seen from these comprehensive tests that the built-up character radio-printer described above constitutes a most reliable and convenient means of printed communication.

The authors wish to take the present opportunity of expressing their appreciation to Mr. R. Tahon of Les Laboratoires, L.M.T. for his assistance during the practical tests.

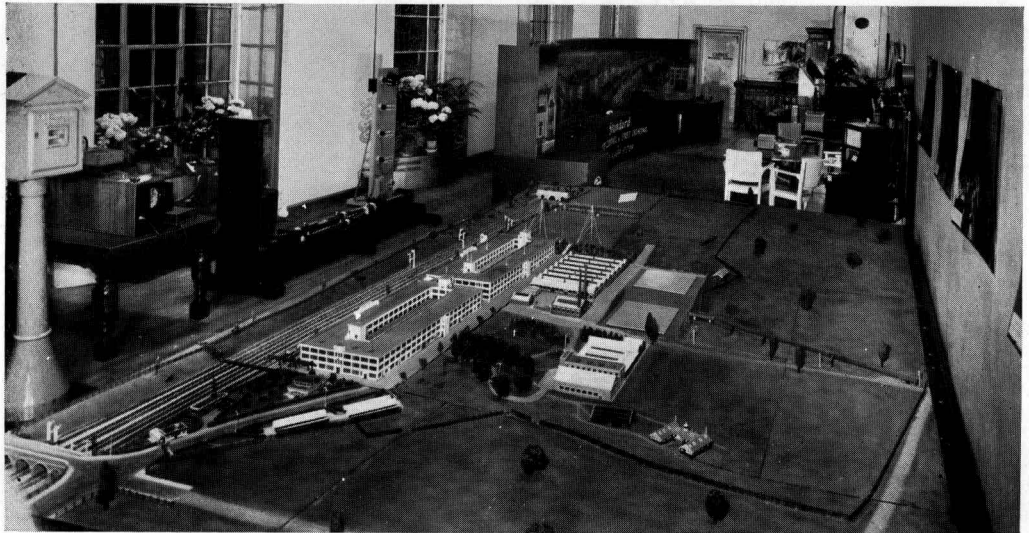

*Standard Telephones and Cables, Ltd., exhibit at the Incorporated Municipal Engineers' Association Convention held at Torquay in May 1938. The display included Remote Control of Street Lighting and Multi-Service System, Remote Control Equipment for Sub-stations, Gamewell Fire Alarm Equipment, Styrenation as applied to Cable Joints, Condensers and Recorder for Transient Phenomena. The centre foreground shows a model of S.T. & Co.'s New Southgate plant.*

# Mix & Genest Switch Type (Citomat) P.A.B.X.'s

By E. FUNCCIUS and E. LAWIN,

Mix & Genest A.G., Berlin-Schoeneberg, Germany

**M**IX & GENEST, since 1931, have specialised in P.A.B.X.'s and have developed a system embodying advantages such as utilisation of a simple design of extension set, utmost economy in line material and flexibility combined with the provision of facilities for meeting a diversity of requirements. The main characteristics of the facilities incorporated in the Mix & Genest system are described herein.

A P.A.B.X. can be installed in a simple manner, as indicated in Figs. 1, 2 and 3. Fig. 1 shows a system for 3 exchange lines with a maximum of 22 extensions; Fig. 2, one for a maximum of 7 exchange lines and 60 extensions; and Fig. 3, one for a maximum of 10 exchange

lines and 97 extensions. Fig. 4 illustrates a P.A.B.X. for 8 exchange lines and 100 extensions with an ultimate capacity of 20 exchange lines and 199 extensions (the stations, cabling, battery, and charging device are not shown). The wiring and cabling of both the switch rack and the attendant's set provide for the maximum capacity of the system so that increased facilities can be provided at any time by merely adding the necessary relay sets and selectors on the switch rack.

Fig. 5 shows a selector frame for 6 final selectors equipped with 4 final selectors. Adding a final selector only involves mounting the selector (Fig. 6), the switch rack and multiple cable for maximum capacity being

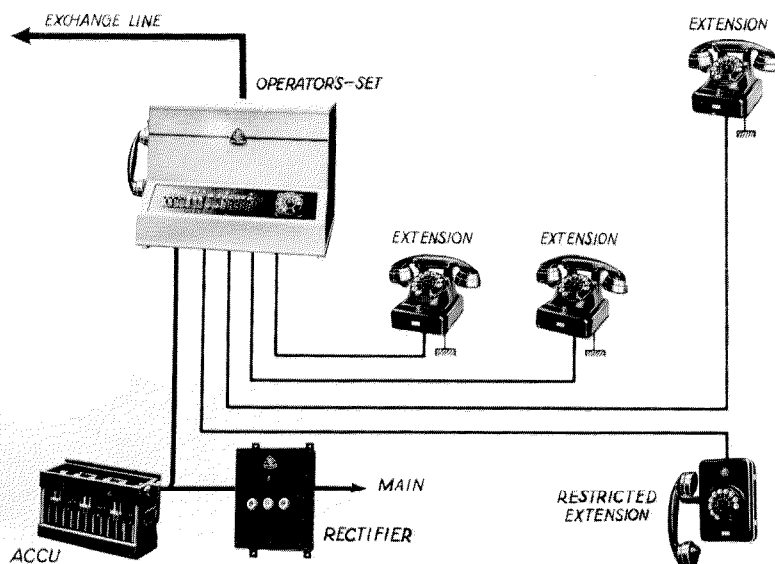

Fig. 1— 3 Exchange Line P.A.B.X. Systems with a Maximum of 22 Extensions.

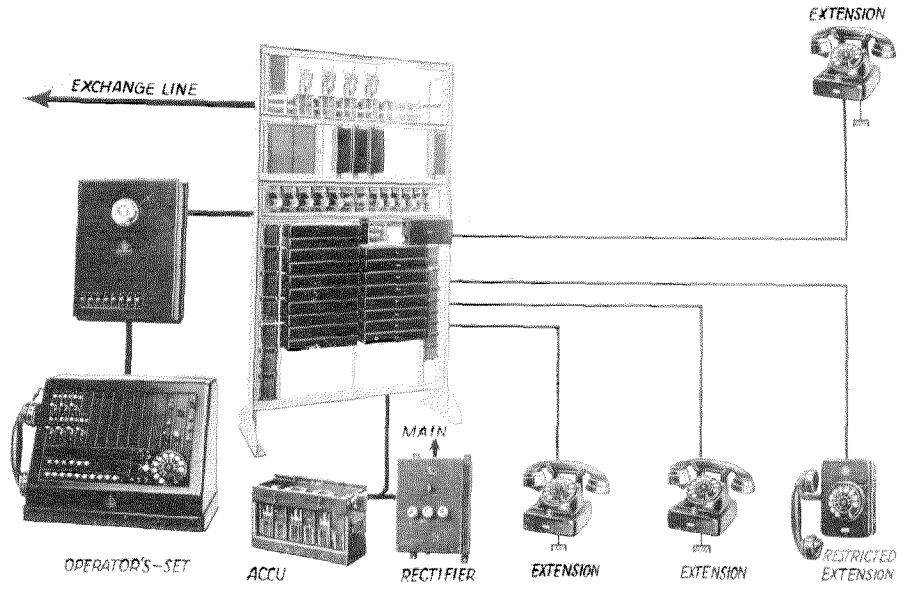

Fig. 2—System for Maximum of 7 Exchange Lines and 60 Extensions.

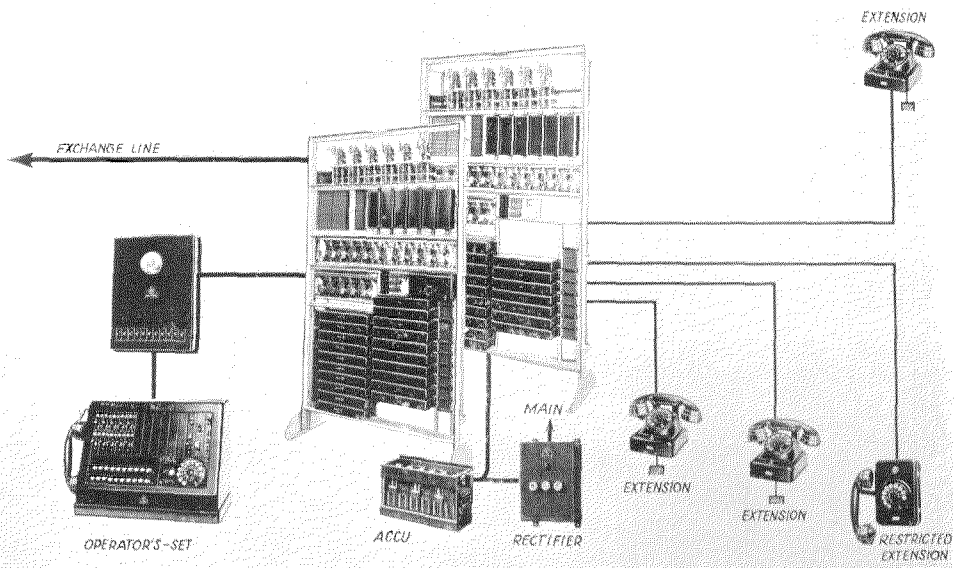

Fig. 3—System for Maximum of 10 Exchange Lines and 97 Extensions.

provided in the initial installation. As already indicated, the addition of a line finder (Fig. 7) also requires only the mounting of the step-by-step switch itself, the contact banks being provided as part of the initial installation (see Fig. 8). When an increase of an exchange line or link is necessary, one completely wired relay set (Fig. 9) can be added. Fig. 10 shows the space for mounting such a set as well as the method of connection to the soldering strips. If 10 P.A.B.X. lines are to be added, a complete relay set with cable is required. This relay set is mounted in the free space provided (Fig. 8), and the cable is soldered to the soldering tags on the cable terminal board at the left. Additions can thus be made easily and quickly.

The following detailed description is limited, in general, to P.A.B.X. equipment with capacities of 3 exchange lines and 22 extensions, but special features incorporated in larger P.A.B.X.'s are indicated.

### 3 EXCHANGE LINE, 22 EXTENSION AND 3 LINK P.A.B.X.

This P.A.B.X. (Fig. 1) can also be equipped with 2 exchange lines, 12 extensions and 2 links, or with 3 exchange lines, 12 extensions and 2 to 3 links. It is a desk type private automatic branch exchange and contains, in addition to the attendant's set, the necessary switches, lamps, relays, selectors, pole-changer, etc. A special switch rack is not required. The selectors are almost noiseless in operation, causing no disturbance in the room where the P.A.B.X. is located.

#### Method of Operation

##### LOCAL P.A.B.X. CALL

Calling station removes the handset and, after hearing dialling tone, selects the desired station. If the latter is free, ringing current automatically operates the called party's bell and the calling station hears the ringback signal.

Called party removes handset; automatic ringing is cut off and the connection is automatically switched through.

If at the end of the conversation both handsets are hung up, the link is free.

By replacing the handset each party is automatically free; therefore, no blocking occurs.

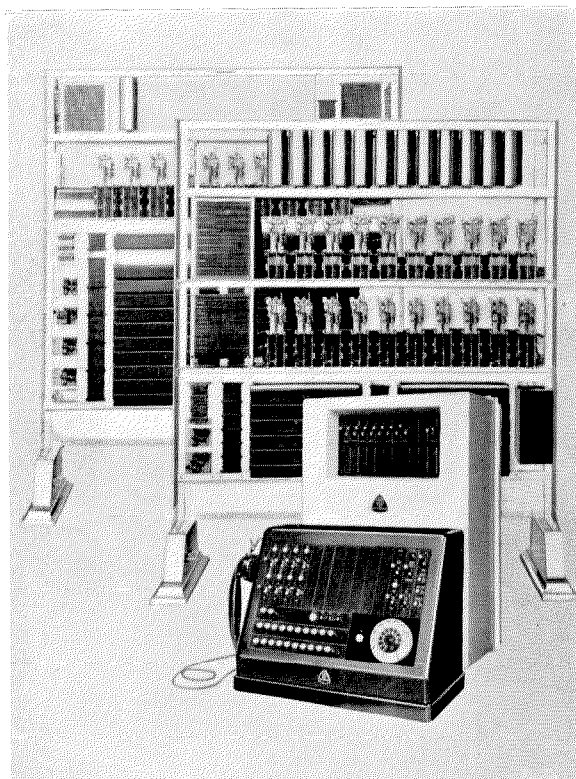

Fig. 4—System for 8 Exchange Lines and 100 Extensions with an Ultimate Capacity of 20 Exchange Lines and 199 Extensions.

If the calling P.A.B.X. party hears the busy signal after removing the handset, all links are busy.

If the busy signal is heard after dialling, the desired extension is busy.

Facilities are provided for the attendant to enter into direct connection with all the sets connected to the P.A.B.X.

##### OUTGOING EXCHANGE CALL

##### (a) NON-RESTRICTED EXTENSIONS

Handset is removed and, regardless of signal, the universal button is pressed once.

Even when all local links are busy, a free exchange line is obtained.

##### *In Full Automatic (F.A.) Exchange Area*

After hearing the public exchange dialling signal, the desired exchange subscriber is dialled.

##### *In Central and Local Battery Manual Exchange Areas*

Exchange operator's answer is awaited.

If a busy signal is heard after pressing the

universal key, all exchange lines are busy. Handset is hung up.

(b) *ATTENDANT'S SET*

Attendant presses control button. Lamps of the busy exchange lines light up. Key of a free exchange line must be operated, also the common dial key.

*F.A. Public Exchange*

After hearing the public exchange dialling signal, the desired exchange subscriber is dialled.

In order to reserve one or all of the exchange lines in favour of incoming exchange calls, provision is made for one blocking key per exchange line.

**INCOMING EXCHANGE CALL**

An incoming exchange call is indicated visually and audibly to the P.A.B.X. attendant.

After throwing over the exchange line key associated with the lamp, the attendant is connected with the public exchange subscriber.

If several exchange calls arrive simultaneously, they can be answered in succession.

Less important exchange calls can be brought into a waiting position in order to give preference to the more important ones.

Connection to the desired P.A.B.X. extension is effected by the attendant dialling the called party's number.

If the red lamp does not light after dialling, the extension is free. When the exchange line key is restored to normal, the supervisory lamp flashes intermittently, indicating automatic ringing of the P.A.B.X. extension bell. When the called P.A.B.X. party answers, the supervisory lamp is extinguished.

Secret calling (preliminary calling) by the attendant to any extension is provided. The exchange line is held while the attendant informs the called party of the exchange call pending.

If a wrong extension is dialled, the connection is cancelled by pressing the common release button.

If the extension is busy, the red lamp lights after dialling. If the calling public exchange subscriber wishes to wait for the disengagement

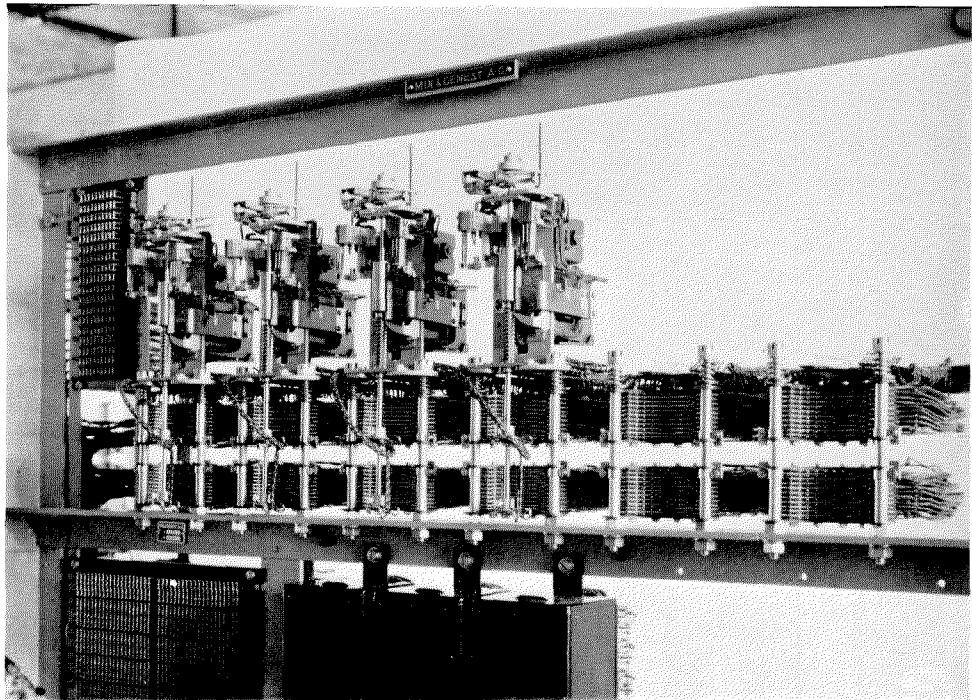

Fig. 5—Selector Frame for 6 Final Selectors (equipped with 4 Final Selectors).

of the extension, the exchange line key is restored to normal. Connection is established, but not switched through. When the extension hangs up after the end of the first conversation, switching through of the waiting exchange line takes place with automatic ringing of the extension. After removal of the handset, connection between this P.A.B.X. extension and the exchange subscriber is established.

When an incoming urgent toll call comes in while the called P.A.B.X. extension is engaged with a local or exchange call, the P.A.B.X. attendant cuts in by first throwing the common call-back key. During the listening-in period a warning tone is given to all three parties.

If a previous exchange line connection is to be held, the common finder key is operated. The supervisory lamp of the first exchange line connection lights.

The attendant operates the associated exchange line key and restores the second exchange line key to normal. She then asks that the handset be replaced temporarily, after which the desired extension is automatically connected with the trunk line.

The attendant restores the call-back key to normal, and informs the waiting public exchange subscriber that, after completion of the urgent call, the connection will be re-established.

The selector of the first exchange line is reset on the extension, by means of the dial, and the exchange line key is restored. The first exchange line connection is established but not switched through. In P.A.B.X. systems with more than three exchange lines and 22 extensions (provided the exchange line connection is established), the lamp of the exchange line flickers in order to indicate that the connection is being held in the waiting position.

#### CALL-BACK BY P.A.B.X. SUBSCRIBER

During an exchange line connection, any extension may call any other P.A.B.X. station.

The universal button is depressed once.

When the dial tone is heard, the desired P.A.B.X. party is dialled, as described above under "Local P.A.B.X. Call."

The call-back being finished, connection with the exchange line is again obtained by depressing the universal key.

Call-back can be made as often as desired.

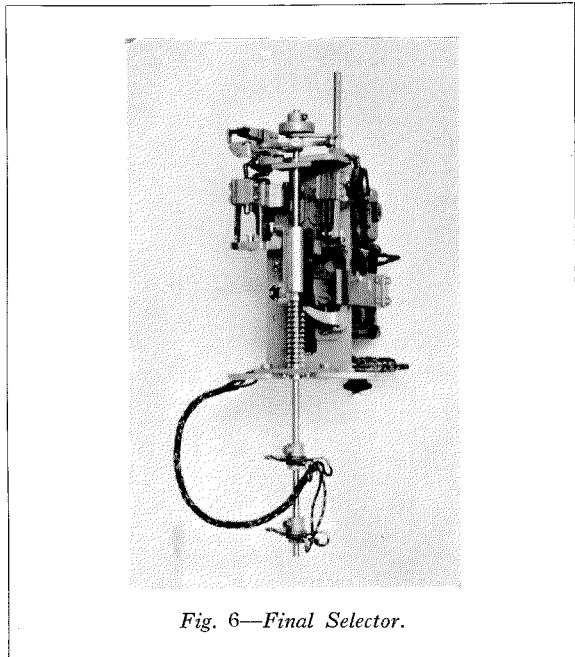

Fig. 6—Final Selector.

#### TRANSFER CALL

If an exchange line is to be transferred from one extension to another, the P.A.B.X. extension, during an in or out exchange line connection, presses the universal button once as described under "Call-Back by P.A.B.X. Subscriber."

After the dial tone is heard, the desired extension is dialled.

When the called party answers and accepts the exchange line, the calling extension restores the handset. The desired P.A.B.X. party is then connected with the public exchange subscriber.

The second extension may make a call-back or again transfer the exchange connection.

If an exchange line is to be transferred from an extension to the attendant's set, the universal key is depressed once and the handset is hung up. The lamp of this exchange line lights on the attendant's set.

The attendant then handles the call as if it were an incoming exchange call (see above, "Incoming Exchange Call").

#### CUT-IN FACILITY

Any extension can give the attendant a signal during an exchange connection.

This is effected by depressing the universal



button approximately three seconds, thus causing the attendant's cut-in lamp associated with the particular exchange line to glow.

The attendant operates the particular exchange line key and the common call-back key, and is then secretly connected with the extension. The exchange line is held.

After the attendant has released the keys, the extension is again connected with the exchange line.

The attendant can transfer the exchange line to any other extension (see above, "Incoming Exchange Call").

#### NIGHT SERVICE

Local and outgoing exchange calls, call-back and transfer of exchange lines by extensions are handled the same as during the day.

Incoming calls on certain exchange lines are received by predetermined extensions individually connected for night service.

Calls on all exchange lines also can be received by a single extension, in which case the central night key is reversed.

Connection between a public exchange subscriber and the extension for night service is effected by the P.A.B.X. party removing the handset.

If an exchange call comes in while the night extension is engaged, the P.A.B.X. party is informed of the call by a buzzer signal. He temporarily restores the handset and is then automatically connected with the calling public exchange subscriber.

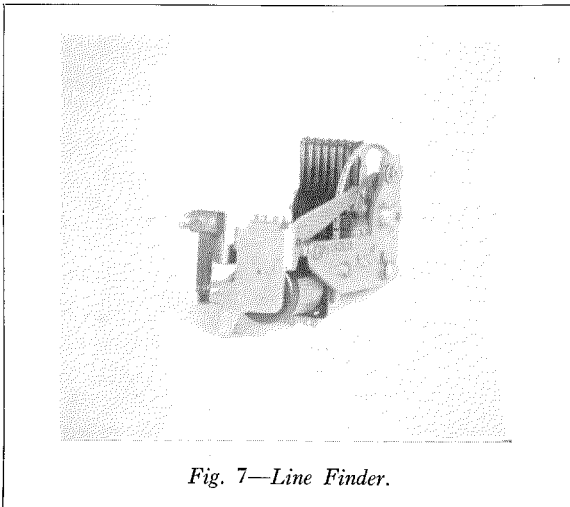

Fig. 7—Line Finder.

Any extension connected to the system, but located in a separate building, etc., can also be used for receiving incoming calls over one or all exchange lines.

#### PARTLY AND FULLY RESTRICTED EXTENSIONS

By severing a wire connection in the system, any extension can be converted into a partly restricted one. Such an extension can only receive an exchange line call through the attendant or a non-restricted P.A.B.X. extension.

By severing an additional wire connection, an extension can be converted into a fully restricted station, i.e., one debarred from making or receiving external calls.

#### Line Equipment

Each inside or outside extension requires a double line and ground or a common return wire.

Each local extension (fully restricted) requires a double line.

The loop resistance per P.A.B.X. extension may amount to  $2 \times 300$  ohms; if higher, repeaters are necessary.

#### LARGER P.A.B.X.'s

Large P.A.B.X.'s, fully equipped, include the following:

Exchange Lines	Extensions	Links
7	60	6 (Fig. 2)
10*	97	12 (Fig. 3)
20	199	20 (Fig. 4)

Each P.A.B.X. can be equipped with fewer exchange lines, extensions and links, if required. The attendant's set and the P.A.B.X. switchboard are separate, i.e., relays, selectors, pole changers, etc., are placed on a special rack (Figs. 2 to 4). A protective cover can be provided for the rack.

For the connection of incoming exchange calls to the extensions, key strips rather than a dial are provided. A dial is used by the attendant to dial over exchange lines and links.

The digits required for the following P.A.B.X.'s are:

3 exchange lines and 22 extensions	..	1, 2 and 3 digits
5 exchange lines and 50 extensions (ultimate capacity 10 and 97, respectively)	..	2 digits
7 exchange lines and 60 extensions	..	2 digits
20 exchange lines and 199 extensions	..	3 digits

\* Initial capacity: 5 lines, 50 extensions and 6 links.

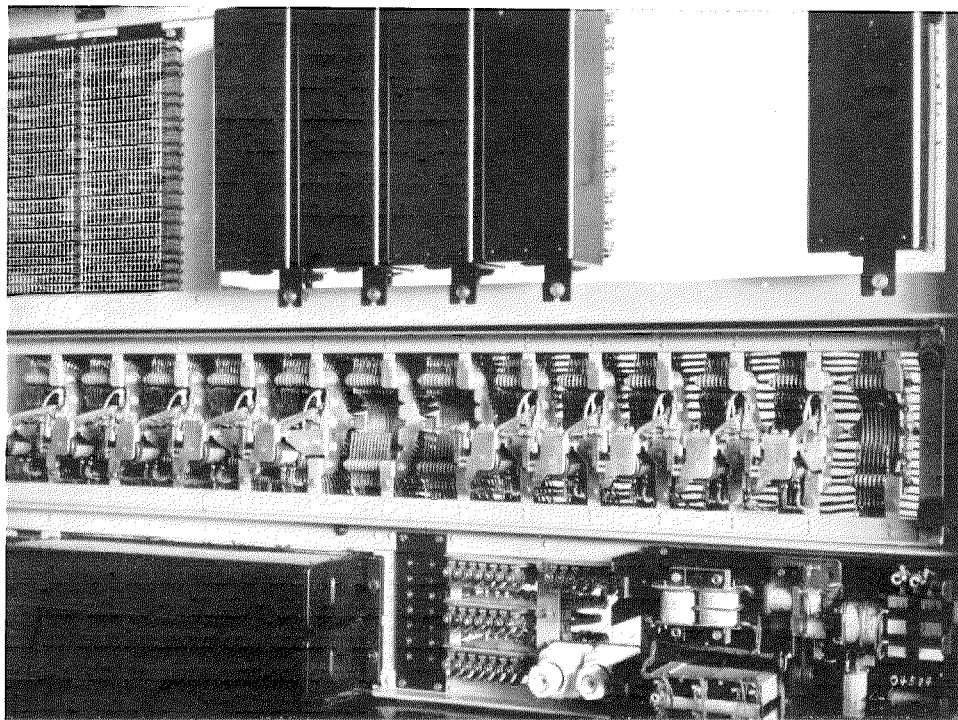

Fig. 8—Line Finder Frame (equipped with 5 line finders for the exchange lines and 5 line finders for local connections).

The operation of the attendant's set and P.A.B.X. stations, as well as the wiring scheme, is fundamentally the same as in the system for 3 exchange lines and 22 extensions.

#### **ADDITIONAL SERVICE FACILITIES AVAILABLE**

##### **Director's and Secretary's Telephones**

A secretarial service facility can be provided for executives, such as directors, general and works managers. All calls can then be initially transmitted to the secretary's apparatus. The simplest system of this kind consists of an executive's and a secretary's set; the arrangement can also be such as to enable the secretary's set to deal with several executives' sets. The extension line is looped via the executive's set and ends at the secretary's set. When a call comes in, the lamp of this line glows on the secretary's set. The call is received by the secretary's lifting the handset and operating the associated extension button. In the case of an important call, the director's set is called via a

special line. The extension key, which is associated with the calling line, is pressed on the director's set and, whilst the secretary's apparatus is disconnected, the director is connected with the calling party. Busy lamps for the looped line are installed to indicate whether the line is free or engaged. The looped line can be connected with a key which, when operated, transfers the call to the director's set. The arrangement also may be such that the call is switched to the director's set automatically within 20 seconds in case the secretary's set does not answer. If neither the director's nor the secretary's instrument responds, the lamp glows only for a certain period.

Each apparatus can also be equipped with a monitoring key and its associated lamp. If the director is having an important conversation which is to be listened to by his secretary or to be reported stenographically, the listening-in key is operated on the director's set. The associated lamp on the director's set glows, indicating that the secretary is listening-in. One or the other of these sets can, moreover,

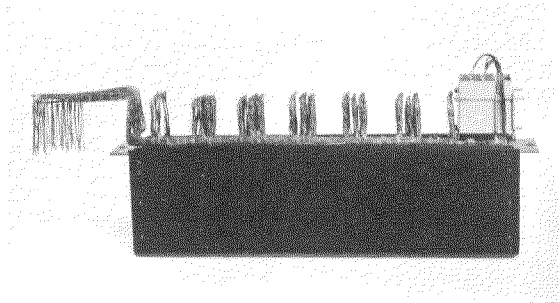

Fig. 9—Completely Wired Relay Set.

be equipped with messenger-keys, door locking devices, etc., as desired. Outgoing calls from the director's set can be established without the intervention of the secretary.

#### Conference Arrangement

The conference feature enables department heads, etc., to be connected to the same line for a conference and is essential when the director or manager wishes to communicate with a number of important persons within a minimum period of time. When the handset on the director's set is lifted and the dial tone of the P.A.B.X. is heard, the number, say 11, is dialled, whereupon the final selector hunts the contacts of the conference equipment. In order that all the desired stations may be reached by one dialling process, the figure "0" is then dialled, the selector of the conference equipment thereupon receiving ten current impulses and, in turn, causing the operation of a relay which connects the conference line relays of the subscribers involved. Actual switching over of these relays takes place when the respective lines become free. The arrangement may be such that a speaker on another connection receives an audible signal as soon as he is needed for the conference. When this audible signal is heard, the existing connection is cut off by temporarily replacing the handset, thereby connecting the desired set with the conference equipment.

It is also possible to call certain selected parties to join the conference line. If, say, P.A.B.X. parties 1, 2, 3, 4 and 5 are required, prefix numbers 11 and 1 are dialled. The conference relay 1 operates, whereupon the selector returns to the normal position. While the selector is operating, a warning signal is

transmitted. When the warning signal ceases, station 2 and the other stations are dialled in exactly the same way. If a station is engaged, a busy signal is transmitted to the calling station. Each P.A.B.X. party may disconnect independently during a conference call. After the conversations have been completed, the link and the conference circuit are released.

#### Code Calling Equipment

If desired, a code calling equipment can be provided. By means of this system, certain persons within the office or building can be easily and quickly located. Indicators with visual and audible signals are placed at appropriate points. When a P.A.B.X. party wishes to locate a person, he lifts his receiver and, on hearing the dial tone, dials a prefix number, say 12. The party making the search is then connected to the code calling equipment via a final selector. By dialling 3, for example, three current impulses are transmitted to an impulse relay and are re-transmitted to a step-by-step switch. After dialling, the lamps designated as 3 in all the indicators are operated; and, in addition, the associated bells start to ring. The person wanted dials the code number, say 13,

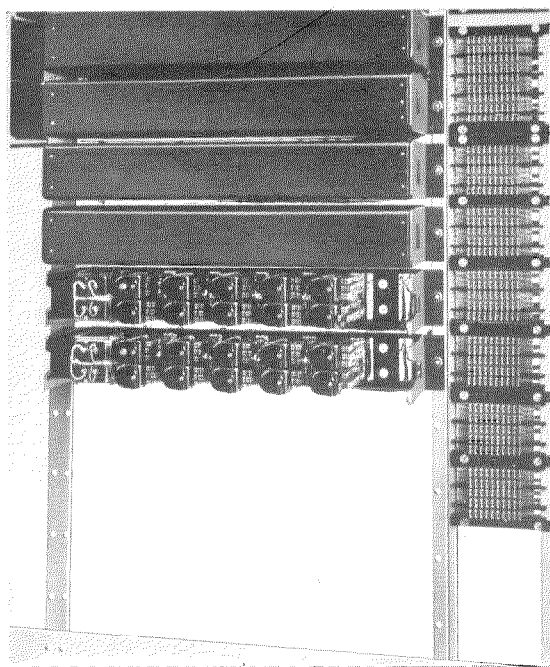

Fig. 10—Rack Showing Space for Mounting Relay Sets and Method of Connection to Soldering Strips.

from the nearest telephone whereupon the desired connection is established. The visual and audible signals are disconnected when digit 13 is dialled.

#### ***Automatic Transfer of an Exchange Call***

Automatic transfer equipment can be installed either in the exchange line relay unit of the P.A.B.X. or in any extension line. If the transfer device is provided in the exchange line relay unit and the attendant does not answer within 20 seconds, the exchange line is switched through to an extension provided for this purpose. Connection with the calling exchange subscriber is established by the predetermined P.A.B.X. party lifting the handset. If an exchange call is received while the extension is busy, the exchange call will be heard in the receiver of the P.A.B.X. party, who will then cut off the existing connection and give preference to the exchange call. This is accomplished by replacing the handset temporarily.

If the automatic transfer equipment is installed in an extension line, each call for this particular extension is switched over, after about 20 seconds, to another extension provided for the purpose. When the bell is rung and the handset lifted, the second extension is connected to the calling subscriber.

#### ***Fire Alarm Equipment***

Arrangements can be made to provide fire alarm equipment in connection with P.A.B.X.'s. To give notice of a fire, the handset of any station may be lifted and, on hearing the dial tone, a code number, say 13, is dialled. The operation of a relay connects a fire alarm telephone set with line 13, even if a conversation is in progress. The fireman on duty is thus immediately connected with the calling party and receives information as to the location of the fire. Release of the connection is controlled by the fireman in order that, in the event of a false alarm, the apparatus from which the alarm was given can be ascertained by the position of the line finder.

#### ***Door Locking Facility for Executives' Offices***

For preferred stations, a visual indicator

outside the room, incorporating a "Keep Out" inscription, is available. The lamps of this board glow while such a station is busy or when the door lamp-switch is thrown. In order to prevent undesired entry, the door can further be equipped with an electric door opener. In order to open the door, a button must then be operated. If, however, the aforementioned switch has been thrown, the door will not open even when the button is depressed.

#### **POWER SUPPLY**

The power equipment for trickle charge required for these P.A.B.X.'s is as follows:

- 3 Exchange Lines, 22 Extensions and 3 Links :  
One 24-volt storage battery, capacity 18 ampere-hours when the P.A.B.X. is fully equipped ;  
Charging Equipment : (D.C. or A.C.) 0.07 to 0.3 amperes, 24 volts.
- 5 Exchange Lines, 50 Extensions and 5 Links ; 7 Exchange Lines and 60 Extensions :  
One 24-volt storage battery, capacity 40 ampere-hours when the P.A.B.X. is fully equipped ;  
Charging Equipment : (D.C. or A.C.) 0.2 to 0.6 amperes, 24 volts.
- 10 Exchange Lines, 97 Extensions and 12 Links :  
One 24-volt storage battery, capacity 80 ampere-hours, when the P.A.B.X. is fully equipped ;  
Charging Equipment : (D.C. or A.C.) 0.6 to 1.2 amperes, 24 volts.
- 20 Exchange Lines, 199 Extensions and 20 Links :  
One 24-volt storage battery, capacity 160 ampere-hours, when the P.A.B.X. is fully equipped ;  
Charging Equipment : (D.C. or A.C.) 2 to 4 amperes, 24 volts.

#### **ADAPTABILITY OF CITOMAT P.A.B.X.'s**

In comparison with manual P.B.X.'s, the M. & G. type P.A.B.X. offers the facility that the attendant is required only for incoming exchange calls. Outgoing public exchange calls, as well as the other service features (local service, call-back, transfer of calls to other extensions) are entirely automatic.

M. & G., P.A.B.X.'s are always available for service, even when unattended. In the latter case, one station can be delegated to attend to incoming exchange calls.

The above described P.A.B.X.'s meet the service requirements imposed for automatic private branch exchange working in public buildings, municipal and government offices, hospitals, factories, warehouses, department stores, docks and yards, power plants, airports, etc.

# Electrical Properties of Aerials for Medium and Long Wave Broadcasting

By W. L. McPHERSON, B.Sc.(Eng.), A.M.I.E.E.,  
Standard Telephones and Cables, Limited, London, England

EDITOR'S NOTE: *Concluding instalment. The previous sections were published in the April 1938 issue of ELECTRICAL COMMUNICATION.*

*The object of this paper is to present in collected form information hitherto either unpublished or else scattered through many different publications, some of which are not readily accessible.*

*The first part of the paper is theoretical, and is devoted chiefly to an exposition of the treatment of an aerial as a dissipative transmission line, and to the statement of formulae whereby the radiation and driving impedance of an aerial can be estimated. Particular attention is given to anti-fading aerials of the mast and loaded-top types. In the case of mast aerials the problems of the current distribution and vertical radiation polar diagram are analysed in detail. An approximate method is given for the derivation of these properties on the basis that the actual current can be replaced by a wattless component as assumed on the conventional theory of sinusoidal distribution, together with an energising current in time quadrature with the wattless current.*

*The second part is devoted to the citation of measured values of current distribution, impedance, etc., from various sources, on both real and on model aerials, and to the discussion of the light thrown by these measurements on the applicability of the general method of treatment previously described.*

## (14) Conversion of Loop Radiation Resistance to Transmission Line Loading

While the "loop radiation resistance" furnishes a convenient means for relating the power radiated with the value of the aerial current at the current loop or antinode, it has no physical reality. The power is radiated not solely at the current loop, but from all parts of the aerial. The actual distribution of power radiation is complex, but for purposes of engineering

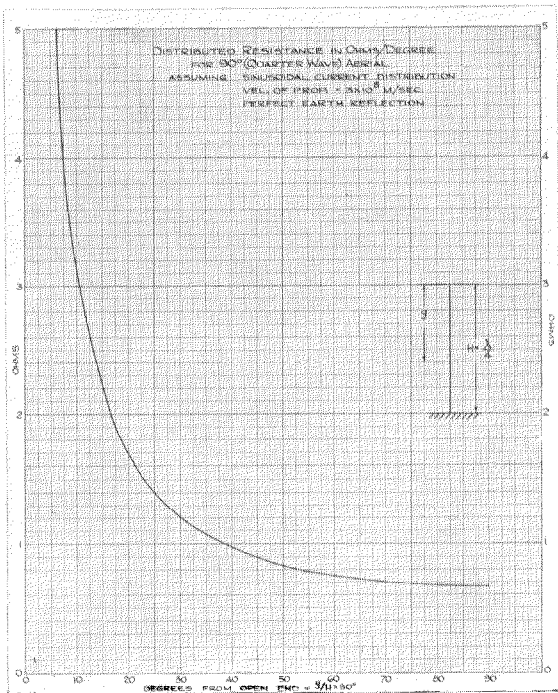

Fig. 3.

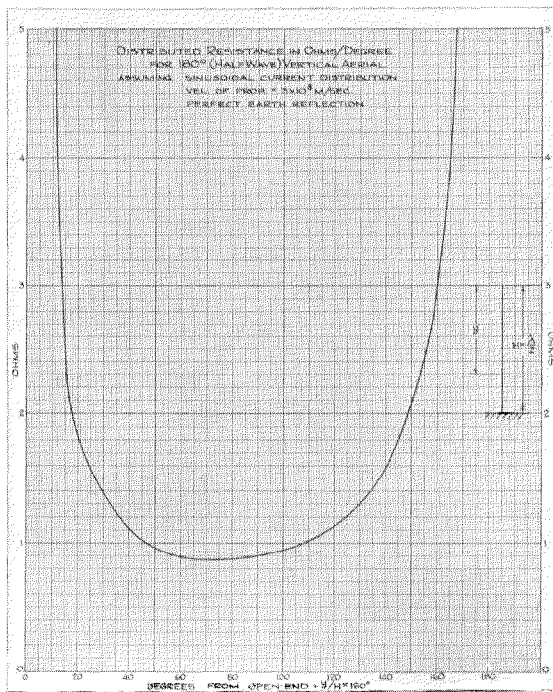

Fig. 4.

computation it is practical to assume that it can be taken as corresponding to the loading of the aerial, considered as a transmission line, by a *uniformly distributed resistance* such that the integral of (current squared  $\times$  resistance/unit length) over the radiating part of the aerial length is equal to (loop current squared  $\times$  radiation resistance) with the conventional sinusoidal current distribution.

That this assumption of uniformly distributed resistance is only an approximation is illustrated by Fig. 3 and Fig. 4, which show the theoretical distribution of resistance due to the radiation load corresponding to sinusoidal current distribution in a quarter-wave and in a half-wave aerial. These curves are obtained by the "induced e.m.f." method of attacking radiation problems (4). While mathematically correct, it must be remembered that even so they cannot correspond to reality since they are founded on the assumption of sinusoidal current distribution, an assumption which is itself incompatible with radiation from the aerial. In practice the agreement between measured aerial impedance values and the values calculated on the uniformly distributed resistance hypothesis is sufficiently good to justify the use of the latter, and indeed suggests that uniform distribution of resistance is closer to reality than the curves just referred to would imply.

Taking the general case of an aerial of height  $H$ , with non-radiating top of equivalent length  $b$  (10), and velocity of propagation as in air,  $B = \frac{2\pi}{\lambda}$ , evaluation of the integral gives the

uniformly distributed resistance per unit length

$$R_0 = \frac{2 R_r}{H \left[ 1 + \frac{\lambda}{4\pi H} \left\{ \sin \frac{4\pi b}{\lambda} - \sin \frac{4\pi(H+b)}{\lambda} \right\} \right]} \dots\dots\dots (35)$$

and  $R_0 H =$  total distributed resistance

$$= \frac{2 R_r}{1 + \frac{\lambda}{4\pi H} \left\{ \sin \frac{4\pi b}{\lambda} - \sin \frac{4\pi(H+b)}{\lambda} \right\}} \dots\dots (36)$$

which is the same for all aerials operated in the same manner, i.e., with the same form of current distribution, independent of the wavelength. The real part of the propagation constant is now

given by  $A \cong \frac{R_0}{2 Z_0}$  and the total attenuation

$$AH \cong \frac{R_0 H}{2 Z_0} \dots\dots\dots (37)$$

In Table IX is given the value of total equivalent distributed resistance  $R_0 H$  for a series of aerials of different heights and different amounts of non-radiating top loading.

It should be noted that the presence of this distributed resistance slightly modifies the characteristic impedance from its lossless value

TABLE IX

Total resistance  $R_0 H$  uniformly distributed over radiating length  $H$  of Vertical Aerial of height  $H$  with non-radiating top termination of equivalent length  $b$ .

$H/\lambda$	$b/\lambda=0$	$b/\lambda=0.05$	$b/\lambda=0.10$	$b/\lambda=0.15$	$b/\lambda=0.20$	$b/\lambda=0.30$
0.125	17.6	23.3	23.5	23.8	23.3	30.3
0.150	26.3	31	33	34	34	31
0.175	36.5	42.5	44.5	44.5	44	38
0.200	47	53.5	57	57	56	43
0.225	60.5	67	70	69	62.5	44
0.250	73	82	84	82.5	76.5	40
0.275	88	97	98	94.5	85	30.5
0.300	104	113	112	106	89	20
0.325	120	127	125	113	88	10.5
0.350	138	143	136	117	83	5.2
0.375	155	155	143	115	71.5	5.7
0.400	168	164	145	107	57.5	12
0.425	181	173	142	97	44.5	22
0.450	192	173	133	81	33	36
0.475	199	169	119	65	25	52.5
0.500	199	159	103	53	25	72
0.525	194	143	87	44.5	32.5	93
0.550	181	125	72	42	40.5	114
0.575	163	106	62.5	46	56	133
0.600	151	93	61	57	72	149
0.625	121	81.5	65.5	71	93	164
0.650	105	79	74.5	88.5	113	175
0.675	93	83.5	89	108	133	176
0.700	91	94	117	127	152	177

of  $Z_0$  given by the equation of section (2), making it

$$\begin{aligned} Z_{01} &= \sqrt{\frac{R_0 + j\omega L_0}{j\omega C_0}} \\ &\cong \sqrt{\frac{L}{C}} \cdot \left(1 - j \frac{AH}{BH}\right) \\ &\cong Z_0 \left(1 - j \frac{AH}{BH}\right) \dots\dots\dots (38) \end{aligned}$$

**(15) Calculation of Base Impedance**

We have now all the data required for an estimate of the base impedance of the aerial, treating the latter as a dissipative transmission line.

If the aerial is of the plain vertical type, of height  $H$ , with no top loading, the base impedance  $Z_b$  is given by

$$\begin{aligned} Z_b &= Z_0 \cdot \coth PH \cdot \left(1 - j \frac{AH}{BH}\right) \\ &= Z_0 \cdot \coth (AH + jBH) \cdot \left(1 - j \frac{AH}{BH}\right) \dots (39) \end{aligned}$$

whence the base resistance  $R_b$  is

$$R_b = Z_0 \cdot \frac{\sinh 2AH - \frac{AH}{BH} \sin 2BH}{\cosh 2AH - \cos 2BH} \dots\dots (40)$$

and base reactance  $X_b$  is

$$X_b = -Z_0 \cdot \frac{\sin 2BH + \frac{AH}{BH} \sinh 2AH}{\cosh 2AH - \cos 2BH} \dots\dots (41)$$

where  $Z_0$  is the characteristic impedance discussed in section (2),  $BH$  is the angular length and  $AH$  is the real component of the propagation factor as discussed in section (11).

If the aerial is short, i.e.,  $\frac{H}{\lambda}$  less than 0.2, the expressions for the base impedance may be simplified to

$$R_b = \frac{R_r}{\sin^2 BH} \dots\dots\dots (42)$$

where  $R_r$  is the loop radiation resistance, and,

$$X_b = -Z_0 \cot BH \dots\dots\dots (43)$$

These expressions can be applied to  $T$  and  $L$  aerials, treated as described in section 8, in which case  $R_b$  can be taken from Table VI without further calculation.

In the case of the loaded top aerial the formulae are more complex. If  $X$  is the reactance of the non-radiating top ( $X = -Z_0 \cot \frac{2\pi b}{\lambda}$ ), the base impedance is given by

$$\begin{aligned} Z_b &= Z_0 \frac{Z_0 \sinh PH + jX \cosh PH}{jX \sinh PH + Z_0 \cosh PH} \cdot \\ &\quad \left(1 - j \frac{AH}{BH}\right) \dots\dots\dots (44) \end{aligned}$$

$$\begin{aligned} &= Z_0 \frac{M \sinh AH + jN \cosh AH}{M \cosh AH + jN \sinh AH} \cdot \\ &\quad \left(1 - j \frac{AH}{BH}\right) \dots\dots\dots (45) \end{aligned}$$

where  $M = Z_0 \cos BH - X \sin BH$   
 $N = Z_0 \sin BH + X \cos BH$

and  $PH, AH, BH,$  and  $Z_0$  have the same significance as in the previous case. The expression for  $Z_b$  has been left in that form which is most amenable to computation.

**(16) Study of Low Impedance (Mast) Aerial**

By means of the data given in the foregoing sections we are now in a position to give provisional figures for aerial performance :

(a) The horizontal figure of merit is determined from the equation

$$F = \frac{1900 K_{90^\circ}}{\sqrt{R_r + R_l}} \text{ mV/m. at 1 km. for 1 kW input;}$$

(b) The polar curve is determined by the general equation

$$F_\theta = \frac{1900 K_\theta}{\sqrt{R_r + R_l}}$$

where  $K_\theta$  and  $R_r$  are given by the equations and tables in sections (5), (6) or (7), while  $R_l$  is estimated, usually at 10 ohms ;

(c) The base impedance is determined by the equations of section (15).

Now all the foregoing is dependent on the admittedly incorrect initial assumption of "lossless" or "sinusoidal" current distribution. Having once established the transmission line constants we are, however, able to form a rather more correct idea as to the true current distribution, and check back from this on the error introduced by our original assumption.

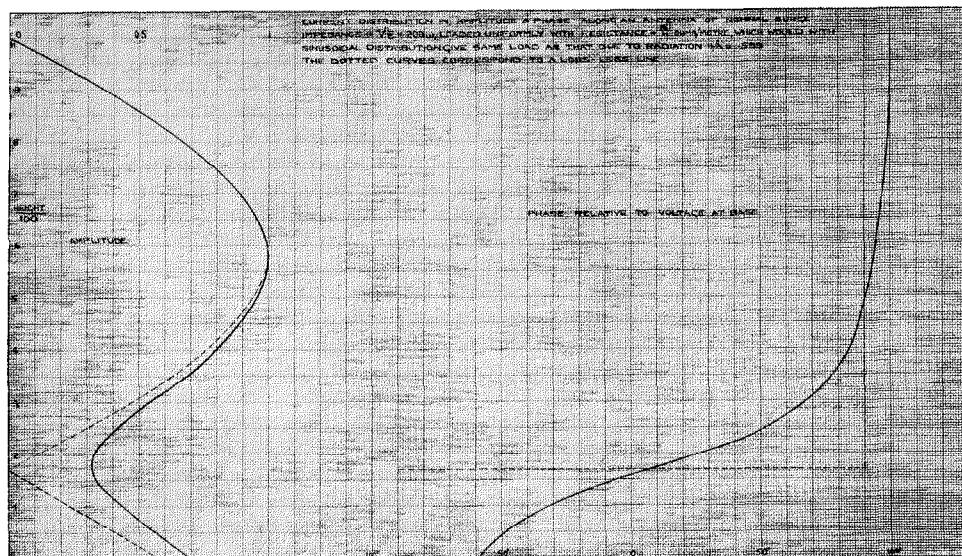

Fig. 5.

The current distribution over the length of the aerial, assuming that there is no top loading, i.e., the case of a pure vertical aerial, is given by

$$I_x = \frac{E \sinh Ay \cos By + j \cosh Ay \sin By}{Z_{01} \cosh AH \cos BH + j \sinh AH \sin BH} \dots \dots \dots (46)$$

where  $I_x$  = current at height  $x$

$y = H - x$

$E$  = base voltage

$A + jB$  = complex propagation constant.

In order to bring out clearly the various factors let us consider the case of a rather long vertical aerial, appreciably longer than a half wavelength, say  $\frac{H}{\lambda} = 0.6$ , angular length  $\alpha_l = 216^\circ$ , physical length 100. Furthermore let us take a low characteristic impedance,  $Z_0 = 200$  ohms, so as to still further emphasise the effect of large attenuation factor  $A$ . Then for this case we have

$$R_r = 65.5 \text{ ohms,}$$

$$R_0 H = 151 \text{ ohms,}$$

$$A = 0.00377 \text{ per unit length,}$$

$$B = 2.16^\circ \text{ per unit length.}$$

Inserting these values in the equation, we obtain the current phase and amplitude given by the full line curves in Fig. 5. For comparison the phase and amplitude corresponding to the original "lossless line" assumption are shown as dotted curves. It will be observed that the zero nodal current is replaced by a current whose amplitude is over 30 per cent. of that at the current loop, while the time phase of the current slowly revolves.

The base impedance  $Z_b$  is found to be 275 ohms  $\angle -59^\circ$ , with a resistance component of 138 ohms. For one ampere at the current loop the base current  $I_{x=0}$  is 0.7 amp., giving a dissipation of 67.5 watts, as compared with our assumed radiation loss of 65 watts for the same value of loop current.

The question now arises as to how the theoretical polar radiation diagram of the aerial is modified by the change in current distribution. By a series of rather laborious graphical integrations the polar coefficient  $K'_\theta$  has been evaluated for the full line current amplitude and phase distribution given in Fig. 5, and is plotted together with  $K_\theta$  on Fig. 6. Here  $K_\theta$  is the polar constant calculated on the conventional basis, i.e., by equation given in section (5). The effect of using "dissipative



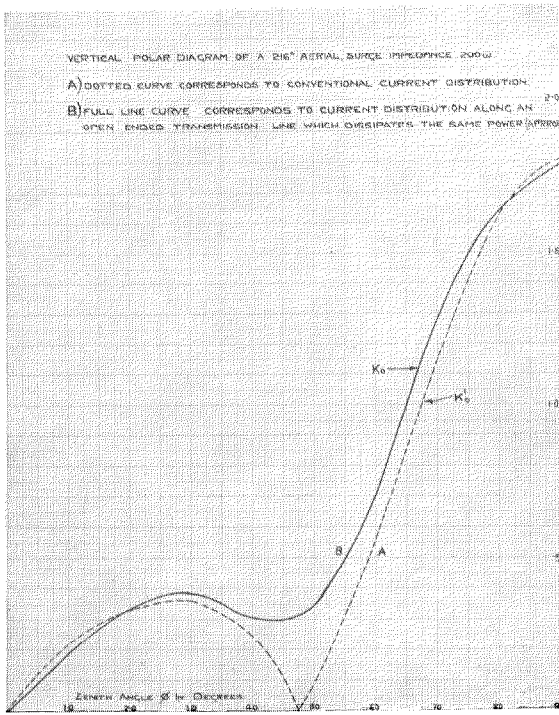

Fig. 6.

line" distribution is that at no zenith angle does the radiation fall to zero (except of course at the vertical) although there remains a marked minimum at what would have been the angle of zero radiation, and the secondary lobe is still evident. The horizontal radiation is hardly affected at all. The loop radiation resistance obtained by further graphical integration, is approximately 68 ohms as compared with our initial assumption of 65.5 ohms, and the value of 67.5 ohms calculated from the base impedance. The agreement is sufficiently close to justify us in the belief that using the conventional value of radiation resistance to obtain the equivalent distributed value will not result in any serious error.

Considering the relatively large change in current at the nodal point it is rather surprising that the radiated power should change so little; presumably this is due to the change occurring at a point which does not contribute much to the total output. As a further refinement we might take the current distribution given by equation (46) and calculate a new value for the distributed resistance  $R_0$ , and so obtain a second correction to the distribution curve; but this hardly seems worth while in view of the

fact that so far everything is based on the assumption that an aerial behaves as a line with uniformly distributed constants. This assumption seems to be very close to the truth, but cannot be wholly correct with an aerial whose proximity to ground varies enormously from base to top.

It is interesting to note the effect of varying  $Z_0$ , keeping  $\frac{H}{\lambda}$  constant. In Fig. 7 is plotted the nodal current in terms of the antinodal current for an aerial of  $\frac{H}{\lambda} = 0.6$ , for values of

$Z_0$  between 100 ohms and 1000 ohms. For wire aerials the practical upper limit of  $Z_0$  is usually taken as 550 ohms, which gives a nodal current about 10 per cent. of the loop current. The lower limit of  $Z_0$  with tower aerials may be taken as 100 ohms, for which value we get a nodal current of 60 per cent. of the loop current. In this case the departure from the theoretical distribution might well cause an appreciable change in the radiation, and remove the appearance of the secondary lobe which is still evident (Fig. 6) with  $Z_0$  equal to 200 ohms.

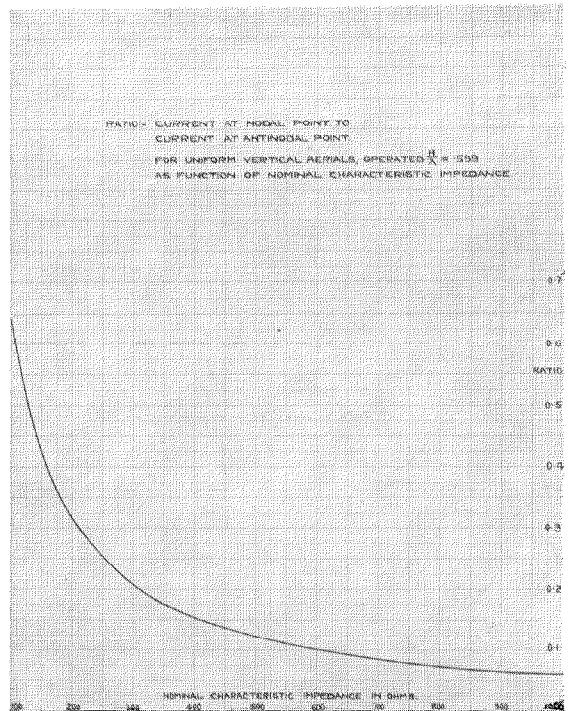

Fig. 7.

**(17) Approximate Current Distribution in Plain Vertical Aerial of Low Characteristic Impedance**

Comparison between the two sets of curves shown in Fig. 5 suggests that the aerial current can be regarded as having a "normal" component corresponding to the conventional distribution in amplitude and phase, and a feed component associated with the energy transfer along the aerial. Taking as our reference current the actual total current at the highest antinodal point ( $By = \frac{\pi}{2}$ ), the current at any other point is given in terms of the antinodal current by the ratio

$$\begin{aligned} \frac{I_y}{I_{y_{90^\circ}}} &= \frac{\sinh Ay \cos By + j \cosh Ay \sin By}{j \cosh Ay_{90^\circ}} \\ &= \sin By \cdot \frac{\cosh Ay}{\cosh Ay_{90^\circ}} - j \frac{\sinh Ay \cos By}{\cosh Ay_{90^\circ}} \\ &\cong \sin By - j \sinh Ay \cos By \\ &\cong \sin By - j Ay \cos By \dots\dots\dots(47) \\ &\cong \sin By - j \frac{R_T y}{2HZ_0} \cdot \cos By \end{aligned}$$

where  $R_T = R_0 H$ .

At the nodal point  $By = 180^\circ$ ,  $y = \frac{\lambda}{2}$ ,

$$\begin{aligned} \text{nodal current} &= j \frac{R_T y}{2H Z_0} \times \text{loop current} \\ &= j \frac{R_T}{4Z_0 H/\lambda} \times \text{loop current} \dots\dots (48) \end{aligned}$$

An alternative approximate method of handling the same problem is as follows. If we assume sinusoidal distribution, then the current at distance  $y$  from the free end of an aerial of height  $H$  is

$$I_y = j \frac{E}{Z_0} \cdot \frac{\sin By}{\cos BH}$$

For unity current at the antinode this gives

$$E = Z_0 \cos BH$$

and the voltage at the nodal point is therefore

$$V = E \frac{\cos 180^\circ}{\cos BH} = -Z_0$$

The magnitude of the feed current at the

nodal point must be such that  $VI$  equals the power fed from the nodal point towards the free end of the aerial. This power is

$$\begin{aligned} W &= R_0 \int_y^0 I_y^2 dy \\ &= -\frac{R_0}{B} \int_{By}^0 \sin^2 \alpha d\alpha, \text{ if } \alpha = By \\ &= -\frac{R_0 y}{2}, \text{ for } \alpha = By = 180^\circ \dots\dots\dots \\ &= VI; \\ \therefore \frac{I_{180^\circ}}{I_{loop}} &= \frac{W}{V} \\ &= \frac{R_0 y}{2 Z_0} \\ &= \frac{R_T}{4Z_0 H/\lambda} \end{aligned}$$

which coincides with the approximate value given by the preceding and more legitimate analysis.

Using the simplification given above, the current distribution is described by

$$I_x = I_{loop} \left\{ \sin B(H-x) - j A(H-x) \cos B(H-x) \right\} \dots\dots\dots(49)$$

The first term corresponds to the normal "lossless" distribution, and is  $90^\circ$  out of phase with respect to the voltage; the second term is at right angles to the first, and is therefore in phase with the voltage; it represents the energising component of the total current.

**(18) Polar Diagram of Plain Vertical Aerial of Low Characteristic Impedance**

The polar coefficient  $K_\theta$  for a plain vertical aerial has been given in section (6) as

$$K_\theta = \frac{\cos\left(\frac{2\pi H}{\lambda} \cos \theta\right) - \cos \frac{2\pi H}{\lambda}}{\sin \theta}$$

This equation is based on the theory of lossless or "sinusoidal" current distribution. In section (16) however it has been shown that if

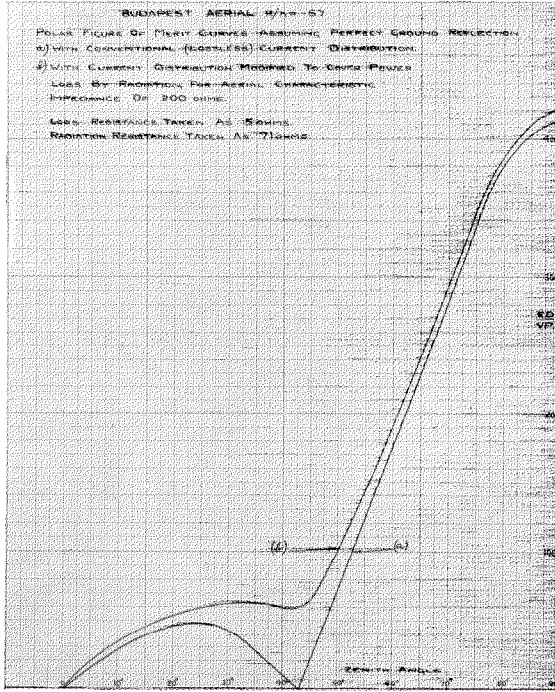

Fig. 8.

the characteristic impedance is low, the current distribution departs appreciably from the sinusoidal form, and that while this departure does not greatly affect the total power radiated it does affect quite perceptibly the polar diagram. It is therefore desirable to modify the original equation for  $K_\theta$  to take account of this low impedance effect. Using the simplified equation for the current distribution outlined in Section (17), we have  $I_x$ , the current at height  $x$ , given by

$$I_x = I_{loop} \times \left\{ \begin{aligned} &\sin B (H - x) - jA (H - x) \\ &\cos B (H - x) \end{aligned} \right\}$$

where  $A$  and  $B$  are the real and imaginary components of the propagation constant.

The current in the aerial thus consists of two components in time quadrature. The first component, proportional to  $\sin B (H - x)$ , corresponds to the conventional current distribution, and gives rise to a polar distribution of the field such that for zenith angle  $\theta$

$$E_{mV/m} = \frac{60 I \text{ amps}}{D_{km}} \cdot K_1 \theta$$

where  $I$  is the loop current, and

$$K_1 \theta = \frac{I}{\sin \theta} \left\{ \cos \frac{2\pi H \cos \theta}{\lambda} - \cos \frac{2\pi H}{\lambda} \right\}$$

The second component, proportional to  $jA (H - x) \cos B (H - x)$ , gives a polar distribution of field such that

$$E_{mV/m} = j \cdot \frac{60 I \text{ amps}}{D_{km}} \cdot K_2 \theta$$

where  $K_2 \theta = AH \left\{ \frac{\sin 2\pi H}{\lambda} + \frac{\lambda (1 + \cos^2 \theta)}{2\pi H} \left( \frac{\cos \frac{2\pi H}{\lambda} - \cos \frac{2\pi H \cos \theta}{\lambda}}{\sin^3 \theta} \right) \right\} \dots \dots (50)$

The total field due to both components is then of magnitude

$$E_{mV/m} = \frac{60 I K_\theta}{D_{km}} = \frac{60 I}{D_{km}} \sqrt{K_1^2 \theta + K_2^2 \theta} \dots \dots \dots (51)$$

where  $\sqrt{K_1^2 \theta + K_2^2 \theta} = K_\theta$ , the modified polar coefficient.

On Fig. 8 are shown the polar figure of merit curves for the Budapest aerial (a) on the conventional current distribution theory, and

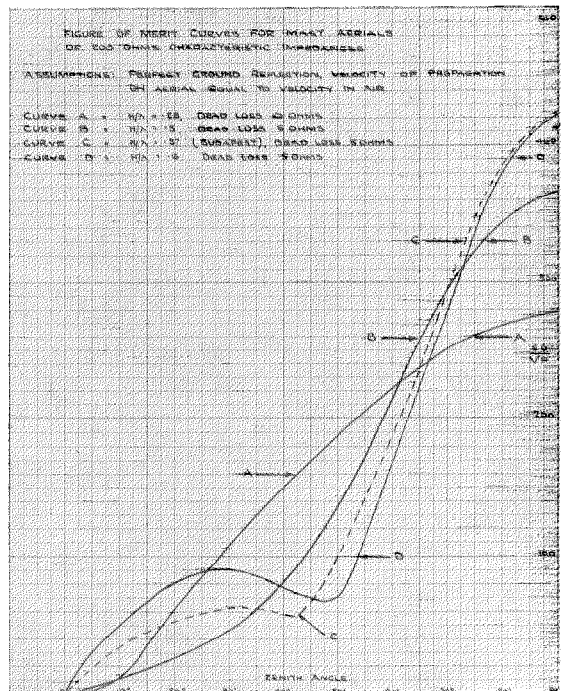

Fig. 9.

(b) allowing for the energy component of aerial current. Curve (a) shows the field passing through zero for a polar angle of about  $42.5^\circ$ . This passage through zero is of course accompanied by a phase change of  $180^\circ$ . Curve (b) shows only a rather flat minimum. This curve, it should be noted, refers to amplitude only, the phase of the field varying continuously with the polar angle; whereas for curve (a) the phase of the field is constant throughout except for the normal reversal on passing through the zero value. For both curves the same value of radiation plus loss resistance has been used; this is not strictly correct, and slightly favours curve (b); but the latter agrees closely with the measured value for  $\theta = 90^\circ$ , and has therefore not been corrected.

Fig. 9 gives polar figure of merit curves for aerials of 200 ohms characteristic impedance for values of  $H/\lambda = 0.25, 0.50, 0.57,$  and  $0.60$ , calculated by the method outlined above. In the case of the quarter-wave aerial the dead loss has been taken as 10 ohms; the shape of the polar diagram is only negligibly affected by the energy component. For the other aerials the dead loss has been reduced to 5 ohms, a value which seems to be borne out by practical results. It will be observed that though the sky radiation of the high aerials is definitely greater than that given by the normal theory, they are still appreciably better than the quarter-wave aerial for polar angles exceeding say  $10^\circ$ .

It might be anticipated that in the case of the low impedance aerial the absence of the sharp minimum between the major and minor lobes of the radiation polar diagram, as evident in a high impedance aerial, would seriously depreciate its anti-fading properties. Actually this is not the case. If the position of the reflecting ionospheric layer were constant it would be possible to select a high impedance aerial with polar diagram such that at some given distance the reflected and interfering ray would originate at this angle of minimum radiation, and therefore be so weak as to reduce fading to negligible proportions. Unfortunately the reflecting layer varies both in height and in inclination to the ground, the height alone varying from about 80 km. to 140 km. As the result of this the reflected ray received at any point varies over several degrees in its angle of emission, the

advantage of the sharp minimum is largely lost, and in practice the average value of interference at a given point is much the same for thin wire and for mast aerials when taken over a long period.

### (19) *Approximate Current Distribution along Low Impedance Aerial Energised at Current Antinode*

Using the same methods as outlined in section (17), we can consider the case where the aerial is fed, not at the base, but at the current antinode, the base being grounded through a suitable tuning reactance. Here the nodal voltage will be as before, if we again assume sinusoidal distribution, but the power to be transferred now corresponds only to the portion of the aerial *below* the nodal point, instead of the long portion above it, and for unit loop current is given by

$$W = \frac{R_0}{B} \int_0^{\pi} BH \sin^2 \theta d\theta = \frac{R_0}{2B} [BH - \pi - \sin BH \cos BH]$$

The nodal current becomes

$$I = \frac{W}{V} = \frac{R_0}{2BZ_0} [BH - \pi - \sin BH \cos BH] = \frac{R_0 H}{2BH Z_0} [BH - \pi - \sin BH \cos BH] = \frac{R_0 H}{2Z_0} \left[ 1 - \frac{\pi}{BH} - \frac{\sin BH \cos BH}{BH} \right]$$

Inserting the values for our  $216^\circ$  aerials of characteristic impedance 200 ohms, the

$$\text{Current at nodal point} = \frac{1.51 \times 100}{2 \times 200}$$

$$\left[ 1 - \frac{180^\circ}{216^\circ} - \frac{\sin 216^\circ \cos 216^\circ}{216^\circ \times \pi/180} \right] = 0.039,$$

as compared with 0.32 for the same aerial fed at the base.

It is evident therefore that with this method of feeding the aerial, i.e., at the current loop, the current distribution is for all practical purposes sinusoidal and independent of the characteristic impedance of the aerial. While there will still

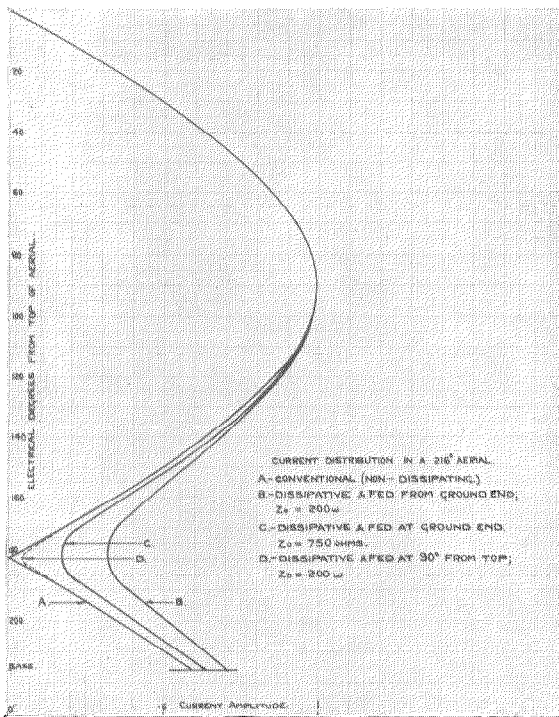

Fig. 10.

be a certain departure from the theoretical polar radiation curve, this departure will be far less than if the aerial were of low impedance and energised from the ground end, and is so small that the formula for  $K_\theta$  given in section (6) can be used without modification.

The value of feeding the aerial at a point near the top is illustrated by the curves in Fig. 10, which give the current distribution along a 216° aerial for different characteristic impedances and methods of feed. It shows that D, a low impedance aerial fed at the 90° point, approaches very near to the ideal, and is definitely superior to C, a high impedance aerial fed at the base, though this latter has the impracticably high impedance of 750 ohms, corresponding to a height/diameter ratio of 140 000. Even with an impedance of 500 ohms the length/diameter ratio is 2 000, and involves an aerial supported on a wood mast such as that used at Breslau.

The system of feeding the aerial at a high point thus definitely overcomes the depreciation of the vertical polar diagram which occurs with a low impedance aerial fed at the base. It gives the self-supporting low impedance radiator some advantage over supported high impedance

aerials fed at the base. The distortion of the current distribution introduced by the impedance factor becomes so small as to be negligible, and comparison between high and low impedance aerials both fed at the 90° point is a matter of cost and convenience rather than of radiation performance.

PART II

DISCUSSION OF SOME EXPERIMENTAL DATA

(20) Cigar-shaped Radiator Towers Guyed at a Single Point

During recent years a great deal of discussion, particularly in America, has centred round the performance of radiators of this pattern. This discussion—(14), (18), (19), (20), (21)—primarily arose from the suspicion that owing to the shape of the radiator the capacity must be distributed in such a manner that the loop current is situated considerably below its theoretical height. Unfortunately there is no means of settling the question by direct measurement of the current distribution, because in this case the changes in cross-section of the mast with height give rise to

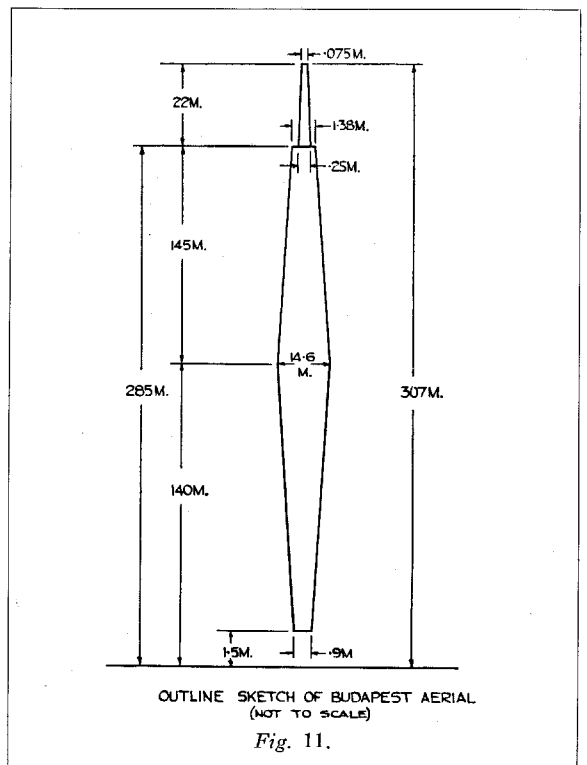

complicated changes in the coupling to any possible measuring device.

A good example of the type of mast construction under consideration is found in the 307 m. radiator erected at Budapest<sup>(13)</sup> to Blaw-Knox design. This mast is of square cross-section and is fitted with only one set of guys, attached at the point of maximum cross-section, which is also a point of low potential. Fig. 11 gives the main dimensions of the mast with the top or "flagpole" section set for a working wavelength of 550 m.

While Fig. 11 quotes the critical dimensions, the fact that it is not to the same scale in both vertical and horizontal directions is apt to give a misleading idea as to the proportioning of the aerial. Actually the height is some twenty times the average width of a side, and the variations in width of side are not of so very great magnitude compared with the height. The aerial is in fact more uniform than it at first appears.

Making all allowances, however, there still remain some dimensional points which inevitably raise queries. One of these is the value of the "flagpole," the top 22 m. section. This is of cylindrical cross-section, tapering from about

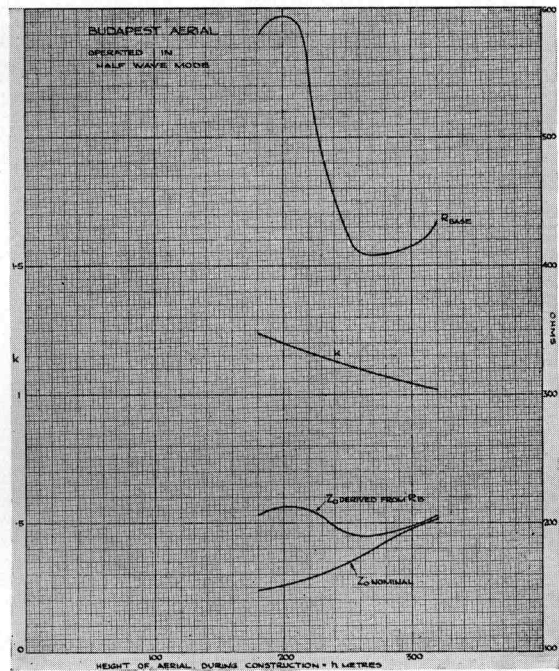

Fig. 13.

25 cm. diameter at the bottom to 7.5 cm. diameter at the top, and can be raised or lowered to give various heights of top section. At the base of this top section the main mast structure has a cross-section of approximately 19 000 sq. cm. or a mean diameter of 155 cm. It might therefore be expected that the pole would be electrically negligible compared with the rest of the structure. That this is not the case is shown by Fig. 12, on which is plotted the wavelength corresponding to approximately half-wave distribution (as judged by high base impedance at unity power factor) for various heights of the mast during the course of erection. It will be observed that the curve extends smoothly from the region below 285 m. height (i.e., no flagpole) to the maximum height of 320 metres, including 35 metres of flagpole. The latter must, therefore, despite its smaller diameter, be reckoned as having equal value with the remainder of the structure in determining the electrical characteristics.

Fig. 12 also shows a similar wavelength-height curve for an 'ideal' aerial. The wavelength of the mast aerial is abnormally long, for the lower range of heights, suggesting that *B*, the imaginary part of the attenuation constant,

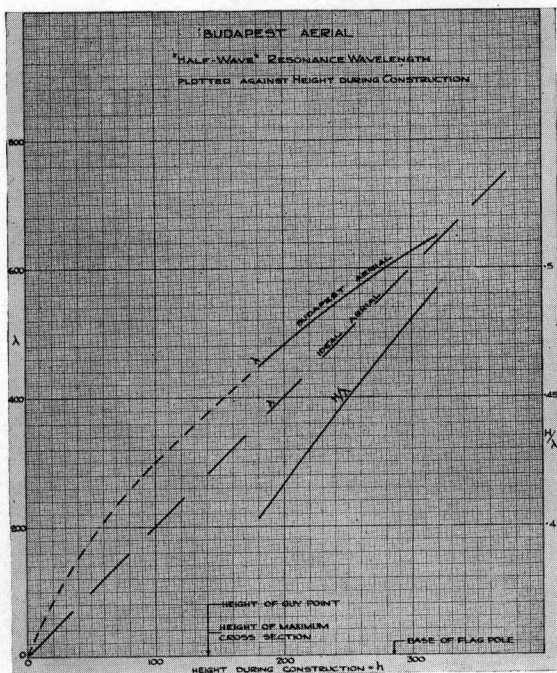

Fig. 12.

is not  $\frac{2\pi}{\lambda}$ , but is something rather greater and changing with the geometrical form of the mast. For the complete mast the discrepancy between the two curves is small. The difference between the theoretical and the apparent value of  $B$  may be partly ascribed to the variation of characteristic impedance along the length of the mast.

Remembering that owing to the inherent coupling between each section of the aerial and its neighbouring sections it is unsound to consider the aerial as composed of a series of separably calculable sections (as witness the effect of the flagpole referred to above), the next simplest hypothesis is to assume that the current is distributed in accordance with uniform transmission line conditions but with a velocity of propagation changed as shown by the wavelength-height curve of Fig. 12, making  $B = \frac{k \cdot 2\pi}{\lambda}$ . We can then calculate the radiation resistance by the method outlined in section (9).

In Fig. 13 is shown a curve of base resistance of the Budapest aerial when excited in the half-

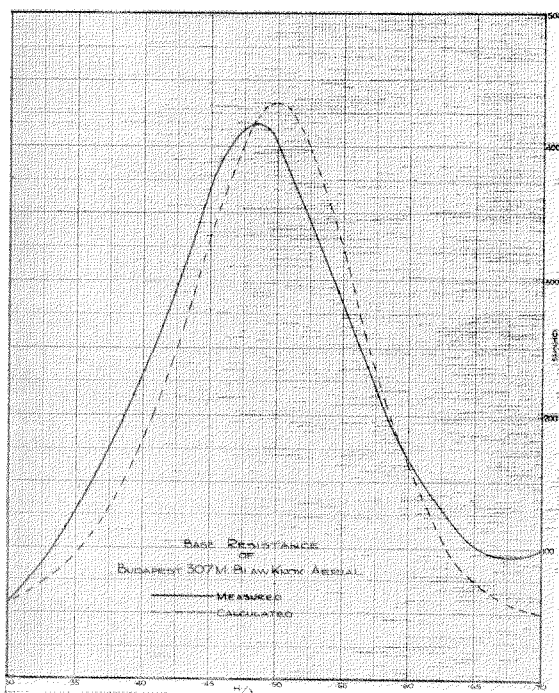

Fig. 14.

wave mode at various stages during erection. We are now in a position to get a rough estimate of the characteristic impedance, by assuming the whole radiation resistance lumped at the end of a quarter-wave line, in which case

$$Z_0 = \sqrt{\text{base resistance} \times \text{radiation resistance.}}$$

The values of  $Z_0$  so obtained are also shown on Fig. 13; they average about 200 ohms, over the range of heights for which measurements are available.

$$\text{Using the formula } Z_0 = 60 \left\{ \log \frac{H}{r} - 1 \right\}, \text{ a}$$

curve of  $Z_0$  "nominal" has been calculated for the aerial at various stages of construction. For the full mast the agreement with the value calculated from the base resistance is rather good; for the truncated mast there is an appreciable discrepancy which is worth considering.

Granting that the characteristic impedance equation is only an approximation, it still seems that the characteristic impedance of the truncated mast should be lower than that of the full mast, for not only has the height been decreased but the average radius has increased, both factors tending in the same direction. On the other hand, the figure deduced from the measurement of base resistance tends to be constant. The divergence between the "measured" and "nominal" curves increases with  $k$ , the agreement being quite good when  $k$  is near to unity.

Now an increase in  $k$  means that  $\sqrt{L_0 C_0}$  is abnormally large. This might be due simply to the change in distribution and magnitude of the A.C. capacity of the aerial with change in current distribution. With an aerial of uniform cross-section, however, we do not encounter changes in  $k$  of such magnitude as we are now dealing with; and it seems more likely that the large values of  $k$  must be attributed to the presence of either excess capacity or excess inductance connected with the shape of the mast. It is surely significant that  $k$  approaches close to its usual value (between 1.0 and 1.05) as the tower approaches completion and becomes more symmetrical, at the same time as the "measured" value of characteristic impedance tends to coincide with the "nominal" value.

The above arguments lead to the following general conclusions :

- (a) For a symmetrical tower or mast such as that used at Budapest, the irregularity introduced by shape is small ;
- (b) When operated in the vicinity of the half-wave mode, such a tower behaves like a uniform transmission line of characteristic impedance approximately 200 ohms, and velocity of propagation similar to that of a thin wire ;
- (c) As the mode of operation is removed from the half-wave point, some change in both characteristic impedance and in velocity of propagation must be expected ;
- (d) As the mode of operation approaches the quarter-wave point, we may expect the characteristic impedance to increase and the velocity of propagation to decrease.

In Figs. 14 and 15 are shown the base resistance and base reactance of the Budapest aerial adjusted to a height of 307 metres, together with theoretical resistance and reactance curves. The theoretical curves have been calculated using the Siegel formula for characteristic impedance (which is taken at the round figure of 200 ohms for half-wave operation), and assuming average velocity of propaga-

tion as in air, i.e.,  $B = \frac{2\pi}{\lambda}$ .

In comparing the theoretical and measured curves, it must be borne in mind that the theoretical curves are based on a whole train of successive approximations. The characteristic impedance has been taken as constant over the whole length of the aerial ; this cannot be absolutely true in view of the varying distance from earth between base and free end of the aerial, and something must also be allowed for changes in cross-section with height. The same factors that affect uniformity of  $Z_0$  also affect uniformity of  $B$ . Still another source of inaccuracy is the assumption that the resistance equivalent to the radiation load is uniformly distributed. This has already been commented on in section (14).

Bearing in mind all these sources of inaccuracy the correspondence between the measured and theoretical curves around the half-wave point must be considered as rather satisfactory. As

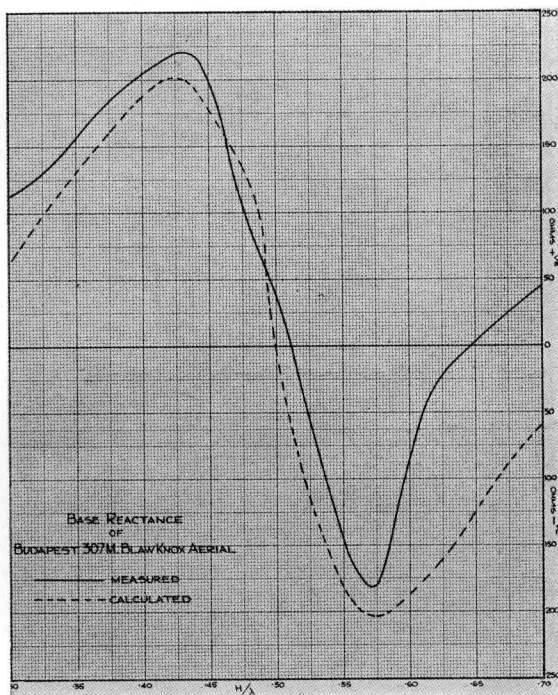

Fig. 15.

we approach the three-quarter wave mode of operation the discrepancy between the two sets of curves becomes serious ; it is probable that part of this discrepancy can be attributed to the increasing difference between the actual current distribution and that given by the conventional " lossless " distribution.

Referring to Fig. 14, it will be noticed that the peak of resistance occurs not at  $\frac{H}{\lambda} = 0.5$

but at about  $\frac{H}{\lambda} = 0.48$ . This peak of resistance

should correspond to zero reactance but, referring to Fig. 15, we see that the zero reactance point occurs at  $\frac{H}{\lambda} = 0.51$ . The

general shape of the measured reactance curve, particularly when taken to values of  $\frac{H}{\lambda} > 0.7$ ,

indicates the presence of an inductive reactance in series with the aerial ; some of this inductance can certainly be accounted for by the thin wire connections used to connect the aerial to the measuring equipment. The same sort of thing has been observed by Morrison and Smith<sup>(22)</sup> in connection with another mast



aerial, and they suggest that the earth system itself presents a small but quite definite amount of inductive reactance. These two sources of error between them probably account for the discrepancy between the maximum resistance and zero reactance points, a discrepancy which after all is not very great. Another factor which has not been taken into account is the shunt capacity across the base insulator; but this is small and should by itself not make very much difference as the theoretical aerial impedance is much lower than the capacity reactance of the insulator. That the inductive reactance effect just referred to is not always noticeable is shown by Fig. 16, which reproduces the composite base impedance curves of five aeriels and is due to Messrs. Chamberlain and Lodge.<sup>(23)</sup> It is understood that these composite curves refer to aeriels similar in general construction to the Blaw-Knox type but without "flagpole."

The measured horizontal figure of merit of

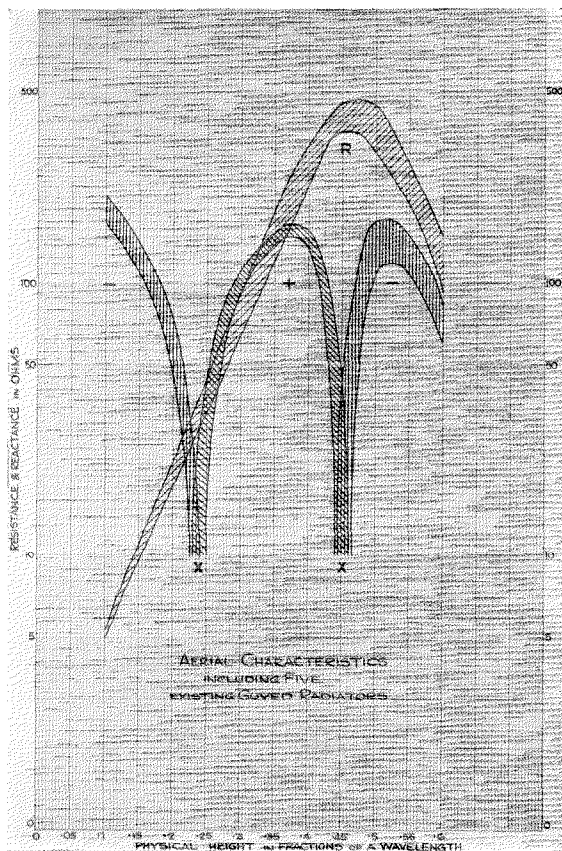

Fig. 16.

the Budapest aerial is 422 millivolts/metre at 1 km. for 1 kilowatt input. This corresponds closely with the value given by the theory of Part I for an aerial with normal propagation velocity and a loop loss resistance of 5 ohms. The range of non-fading reception is reported as 180 km. to 200 km.

It has been contended by Roder<sup>(19)</sup> that in this type of mast the current loop is seriously displaced downwards. In support of this contention he has attempted to obtain the current distribution by replacing the aerial by a series of concentric tubular transmission lines with large fixed outer diameter, and inner diameter corresponding to the average of the aerial diameter over the section, using 15 sections in all. It is felt that this system of analysis is subject to two serious errors. First, it is very dangerous to split up the aerial into separate sections each having properties dependent upon the dimensions of that section alone, since the electrical properties of any given point of the aerial are closely related to the current distribution at all other points, as mentioned in section (2) and confirmed by the absence of any sharp transition point in Figs. 12 and 13 at the junction of the flagpole to the main structure. Secondly, each section of the aerial has been considered as non-dissipative with its reactance calculated accordingly and, while this might be justified for one short open-ended section, the effect of ignoring the resistance component altogether is to create an error of rapidly increasing seriousness every time an additional section is added. (To illustrate the seriousness of the effect, an open section a quarter wavelength long on a non-dissipative basis has zero impedance, while if we allow for the radiation load its impedance is changed to 36 ohms resistance.) Thus the attempt at accuracy by subdividing the aerial into 15 sections is self-destructive, and the current distribution curve calculated on this basis cannot even approximately correspond to reality. Incidentally such a current distribution would result in an aerial which would not give a unity

power factor impedance until  $\frac{H}{\lambda}$  was made

something like 0.75 or even greater, whereas Figs. 14 and 15 show unity power factor for a

value of  $\frac{H}{\lambda}$  close to the theoretical 0.5.

### (21) Measurements on Models of Cigar-shaped Radiators

Pursuing the problem of current distribution on cigar-shaped masts, Messrs. Gihring and Brown<sup>(21)</sup> constructed some small models operated on short-waves so as to give the same  $\frac{H}{\lambda}$  ratio. The current at any point in the aerial was taken as proportional to the magnetic flux opposite that point at some fixed distance therefrom and the flux measured by a wavemeter. "This consisted of a small coil (two turns), a small variable condenser and a thermal milliammeter. This wavemeter was placed on a support which enabled it to be moved parallel to the axis of the antenna. The wavemeter was kept at a large enough distance from the antenna axis so that wavemeter readings remained constant as the antenna was rotated about its vertical axis. . . . Then the current at the height of the wavemeter is proportional to the wavemeter reading." It is essential to the success of this method that the flux be measured as close to the aerial as possible since the flux at a point distant from the aerial is the algebraic sum of the fields set up at that point by all the current elements in the whole length of the aerial. The condition that "the wavemeter was kept at a large enough distance from the antenna axis, etc.," is, therefore, incompatible with measurements of the true field. No information is given as to the actual distance of the wavemeter from the aerial axis, and the observed measurements are not shown on the curve of deduced current distribution; it is, therefore, impossible to arrive at the factors which might correct for the distance effect. The current distribution curves shown by these writers all exhibit a current loop displaced downwards; this is exactly the effect to be expected if we take the true current distribution as corresponding to that on a low characteristic impedance transmission line and then allow for the contribution made opposite any point on the aerial by the current at other points.

Other experiments on short-wave models have been made by Berndt and Gothe.<sup>(24)</sup> In this case two model cigar-shaped aerials were placed horizontally and back to back so as to

give the effect of an image in the ground without actually involving the reflecting properties of the ground. Fig. 17 taken from their article shows the polar radiation diagram for two aerials, each with  $\frac{H}{\lambda} = 0.56$  and slightly different formations, one having a "flagpole" termination and the other no "flagpole." These diagrams agree in general formation with those calculated on the uniform transmission line basis and show a definite improvement in reduction of sky radiation as compared with a normal quarter-wave radiator, while also showing that the major and minor radiation lobes merge together without passing through the zero value given by "lossless" current distribution.

Current distribution measurements have also been made by Berndt and Gothe on model uniform cross-section masts and these correspond very closely with the distribution given by the dissipative transmission line theory.

### (22) Radiators of Uniform Cross-section, Guyed at a Single Point

When a radiator is of uniform cross-section

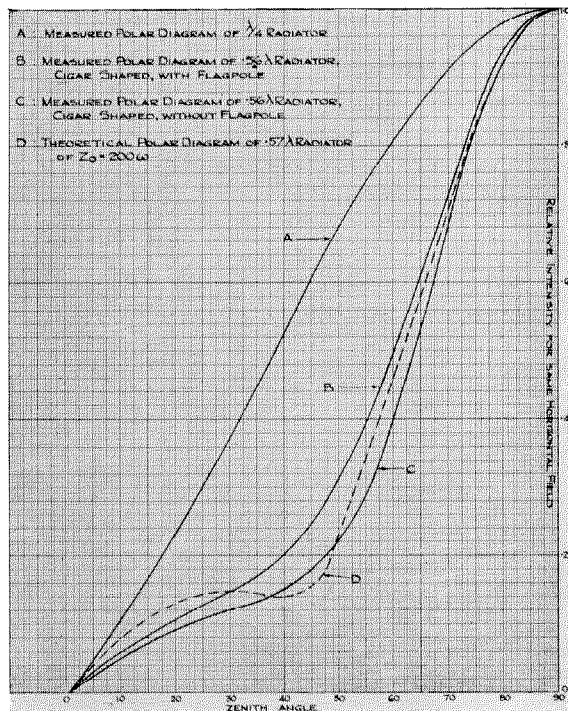

Fig. 17.

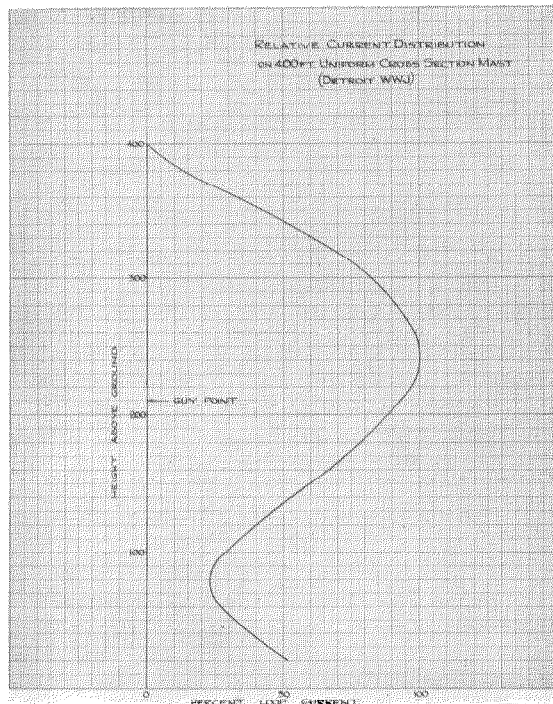

Fig. 18.

it becomes feasible to obtain measurements of the relative current amplitude over a large part of its length. In Fig. 18 is shown such a current distribution curve for a 400 ft. mast, Fig. 19 giving the measured base impedance of the same mast. (Both curves are taken from a monograph<sup>(22)</sup> by Morrison and Smith.) The mast in question is of square cross-section ( $6\frac{1}{2}$  ft.  $\times$   $6\frac{1}{2}$  ft.) over its whole length, except for the lower 22 ft., which tapers down to the diameter of the supporting insulator. One set of guys is attached at a height of about 210 ft.

On examining Fig. 18 it will be seen that while the general shape of the current distribution curve corresponds to that given by the transmission line theory, there is a certain amount of compression, i.e., the phase component of the propagation constant is not  $\frac{2\pi}{\lambda}$

but  $1.06 \times \frac{2\pi}{\lambda}$ . Using the compressed aerial formulae of section (9), with  $k = 1.06$ , we find that for a frequency of 1 450 kc. the loop radiation resistance is approximately 48 ohms, and  $K_\theta$  for horizontal radiation is 1.6, giving (on a no-loss basis) a figure of merit of

$$F = \frac{1900 \times 1.6}{\sqrt{48}} = 440 \text{ mV/m. at 1 km. for } 1 \text{ kW input.}$$

This agrees very closely with the mean observed figure of merit.

Referring to Fig. 18 again, the nodal current is seen to be approximately 23 per cent. of the loop current; for a low velocity aerial this ratio should equal  $\frac{R_0 H}{4 Z_0 k H/\lambda}$ . Inserting the

numerical values ( $k$  deduced from Fig. 18 and  $R_0$  calculated from  $R_{loop}$  and  $BH = \frac{2\pi k H}{\lambda}$ ), we find that  $Z_0 = 190$  ohms. This does not compare very well with the value of about 220 ohms given by the normal formulae based on the mast dimensions, but the disagreement cannot be considered as either serious or surprising when it is remembered that these formulae are founded on current distributions known to be in error.

Turning now to the base impedance curves shown on Fig. 19, it will be noticed that these suggest a very serious decrease of velocity. The half-wave mode of oscillation for example, appears to correspond to  $H/\lambda$  equal to 0.425, giving  $k = 1.18$ . The measured current distribution curve, however, indicates that  $k$  is of the order of only 1.06. The discrepancy between the theoretical and observed impedance values can be accounted for, according to the writers of the monograph, by a series reactance of 6.8 microhenries in the earth system, and a capacity of about 200 micromicrofarads in shunt with the aerial base. Of this the base insulator itself would supply only about 30 micromicrofarads; the remainder may come from the disturbance in the distribution of capacity along the aerial due to the proximity of the earth. In order to illustrate the possible magnitude of this effect, reference may be made to Fig. 20, in which is plotted the distribution of capacity along 100 ft. of an aerial of constant radius 3.38 ft., with its lower end at heights of from 2 ft. to 5 ft. above the ground. This curve has been calculated by Howe's method, which assumes a uniformly distributed static charge, and, therefore, cannot be wholly valid for the high frequency case, but at least it indicates the order of magnitude of the effect

to be expected. It shows that over the first few feet nearest the ground the capacity per unit length is very much higher than over the remainder of the aerial and is easily enough to justify us in considering these first few feet as behaving rather as a shunt capacity than as a section of transmission line of the average characteristic impedance of the aerial.

The expression for the distributed capacity at the extreme base of the mast can be simplified to

$$C_{\mu\text{F}/\text{ft.}} = \frac{33.8}{\log_e \frac{4h}{r}}$$

where  $r$  = radius of mast,  
 $h$  = height of base above ground.

We may, therefore, consider all masts of the same radius, raised to the same height above ground, to have much the same excess base capacity, independent of their height. On the other hand the mean capacity per unit length (which governs the characteristic impedance) definitely involves the height as well as the radius.

In addition to the effect of the earth in increasing the capacity distributed along the length of the aerial, there must also be considered the "end capacity" of the aerial, i.e., the capacity to earth of the horizontal surface at the base. This is probably just as large a factor in the total stray capacity as is the increase in the distributed capacity, but it is also just as difficult to estimate with any degree of accuracy, since

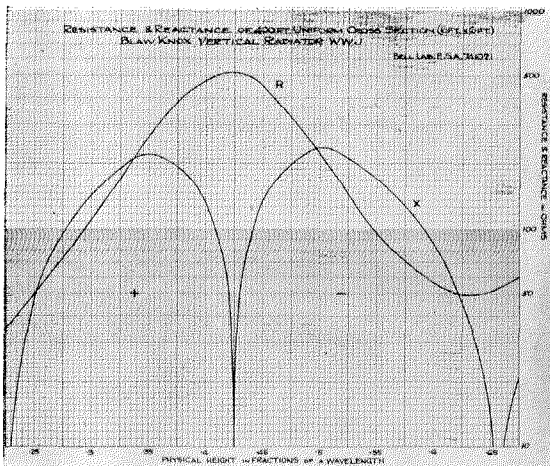

Fig. 19.

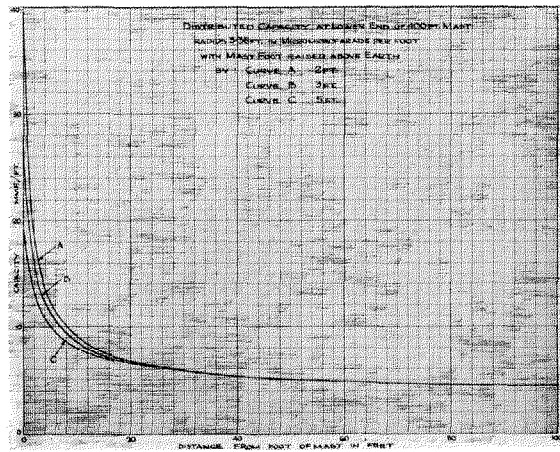

Fig. 20.

mast aerials are not simple cylinders in shape. When they are tapered at the base (as in the Budapest and Detroit cases) it may be expected that both the earth effects will be smaller than for a purely cylindrical structure; this will apply more particularly to the "end capacity," which is roughly proportional to the mast radius, and to a lesser extent to the distributed capacity, which varies with the logarithm of the mast radius. In all cases the height of the mast foot above ground is a major factor.

Accepting the fact that there may exist quite a large stray capacity shunt across the aerial-earth system, it becomes clear that aerial base impedance curves must be interpreted with caution. What looks like low velocity of propagation may really be a shifting of the resistance maximum due to the stray capacity tuning with the true aerial inductive reactance; and an effect of this nature must always be looked for, particularly where the base of the aerial is brought very close to ground, say by the use of short base insulators. If the resistance maximum is shifted only slightly, this may be taken as evidence that there is little compression and only a small excess shunt capacity; a large excess shunt capacity apparently compensated by "expansion" of the standing wave on the aerial is unlikely, since loading of any kind—capacitive or inductive—has the effect of lowering the velocity of propagation, and can never increase it. If violent changes in characteristic impedance occur at some point on the aerial there is, of course, the chance that the effect of the impedance discontinuity may be

to simulate expansion of the standing wave; such an apparently violent change occurs at the junction of the flagpole to the main structure in the Budapest radiator, but as already remarked it does not appear to affect the characteristic to any noticeable extent.

### (23) Effect of Guy Wires

Reference to the current distribution curve of Fig. 18 shows nothing to indicate that the guy wires have any appreciable influence. This may be partly because they are located near a voltage node. It is more likely, however, that the main reason for their innocuousness is that they are broken up by insulators into lengths which are too short to resonate, and that their characteristic impedance is so much higher than that of the mast (owing to their thinness) that their capacity effects are negligible compared with that due to the mast itself. The fact that they are connected near a voltage node is, of course, helpful, as it means that the insulators which break up the guys are not subjected to any great electrical stress. In the case of a mast guyed at several points, it is probable that at least the top set of guys would be under considerable voltage stress, and might have some effect.

It should be noted that in the mast radiator the low value of characteristic impedance which is responsible for the large ratio of nodal current to loop current is also responsible for a considerable decrease in the voltage at the free end as compared with that which would be encountered in a high impedance aerial operated in the same mode. The effect of the guys as absorbers of energy through the insulators is, therefore, less important with mast aerials than with wire aerials. At the same time it must be remembered that this "impedance effect" is fundamentally due to the large damping factor or ratio of radiation resistance to characteristic impedance; and that, if the mast is operated at values of  $H/\lambda$  less than 0.25, the radiation resistance and hence the damping factor is so much reduced that very large voltages may be encountered towards the free end of the mast, while at the lower end the driving voltage is so increased by the high ratio of aerial reactance to resistance that there also high voltages are encountered. The magnitude of the voltages to be dealt with can be gauged from Table X, in which are given comparative figures for half-wave and eighth-wave aerials of the mast ( $Z_0 = 200$  ohms) and thin-wire ( $Z_0 = 500$  ohms) types, calculated on the uniform dissipa-

TABLE X  
VOLTAGE DISTRIBUTION ALONG PLAIN VERTICAL AERIAL FOR INPUT 100 kW

Type of Aerial	Mast		Thin Wire	
	$Z_0 = 200$		$Z_0 = 500$	
Angular length $BH$ .. .. .	180°	45°	180°	45°
Loop radiation resistance $R_r$ .. .. .	99.5	3.2	99.5	3.2
Distributed Resistance $R_0H$ .. .. .	199	17.6	199	17.6
$AH = \frac{R_0H}{2Z_0}$ .. .. .	0.497	0.044	0.199	0.0176
Base Resistance .. .. .	435	6.5	2 045	6.5
Base reactance .. .. .	0	200	0	500
Base impedance .. .. .	435	200	2 045	500
Current for 100 kW .. .. .	15.2	124	7	124
Base Voltage .. .. .	6 600	24 800	14 310	62 000
Voltage at mid-point .. .. .	1 460	32 400	1 400	81 000
End Voltage .. .. .	5 850	35 000	14 000	88 000

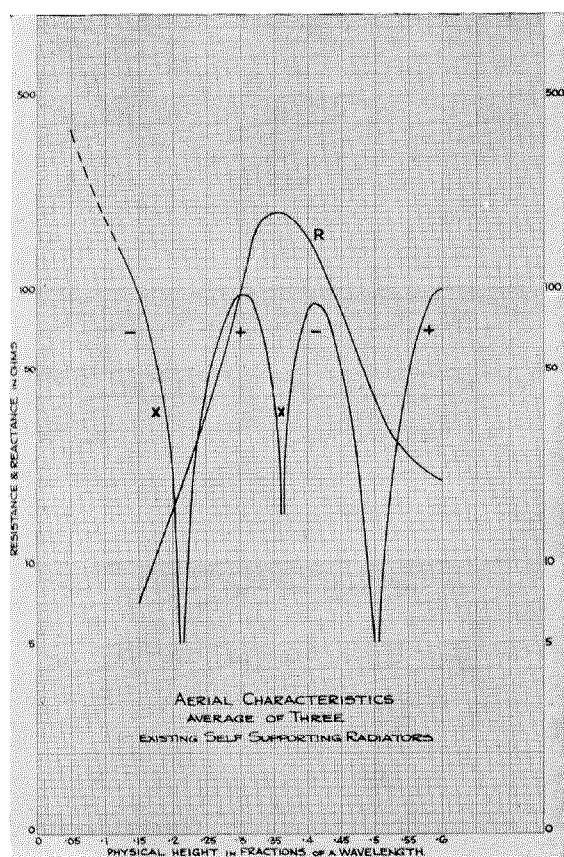

Fig. 21

tive transmission line theory,

$$\text{i.e., } E_x = E_{\text{base}} \times \frac{\cosh P(H-x)}{\cosh PH}$$

where  $x$  is the height above base.

It may be remarked that in Table X no account has been taken of earth resistance; this does not affect appreciably the voltage figures for half-wave operation ( $BH = 180^\circ$ ) but for eighth-wave operation the voltages in practice would probably be 30 per cent. to 40 per cent. lower than indicated, since the earth resistance for this mode of operation is at least comparable with the radiation resistance. Even making this correction, however, it is evident that stay insulators on mast aerials operated around the half-wave mode are subjected to only comparatively small voltages from the aerial itself, particularly so if connected near the voltage node. Using suitably sectionalised guys, there is, therefore, little likelihood of any marked effect from the stays

with mast aerials, although a rather different picture would be presented by a thin wire aerial.

For an aerial operated in the half-wave mode the voltage at the mid-point would be zero on the "lossless" current distribution theory; the change from zero to some finite value as shown on the table is due to the power dissipation element being taken into consideration, and reflects the corresponding difference in current distribution as discussed in Section (17). In the case of the thin wire high impedance aerial the (nodal) mid-point voltage, while numerically about the same as for the mast aerial, has a much lower ratio to the base voltage, in the same way as the nodal current has a lower ratio to the loop current.

#### (24) Self-supporting Towers

Very little data suitable for analysis has been published in connection with towers of this type. For mechanical reasons the cross-section is a maximum at the base, tapering slowly to the top, the ratio, length/maximum side, in the case of square towers being of the order of twelve or fourteen to one, as compared with rather over twenty to one for the cigar-shaped radiator. It is obvious that with such a shape the capacity distribution must be far from uniform and specially concentrated near the base.

Fig. 21, due to Chamberlain and Lodge,<sup>(23)</sup> shows the average measured base impedance of three self-supporting towers. The half-wave mode of oscillation appears to occur at  $H/\lambda = 0.35$  instead of at  $H/\lambda = 0.5$ , but there is little doubt that much of this shift is due to the excessive base capacity. In the absence of definite information as to the current distribution it is unsafe to draw any information from the curve as to the probable average characteristic impedance. From the general shape-ratio one would calculate this as about 150 ohms; this figure lines up qualitatively at any rate with the base impedance measurements, particularly when these are compared with the measurements on the narrow-based masts of Figs. 14, 15, and 19.

Owing to the abnormal "direct-to-earth" base capacity of the self-supporting tower the ground immediately under the tower has to carry an appreciable dielectric current which

shows up as an abnormal loss. It has been pointed out by the authors just cited and by others that this loss can be almost entirely eliminated by providing a metallic earth screen under the base of the tower and a foot or so above ground, extending some feet beyond the mast base; or, alternatively, by in effect raising the entire mast by insulating it not at ground level but at a height of about twenty feet.

#### (25) *Aerials with Non-Radiating Tops*

Self-supporting mast aerials with non-radiating (capacity) tops have only recently come into use,<sup>(25), (26)</sup> and no measurements in connection therewith appear to have been published to date. There is, however, no reason to believe that the addition of the capacity termination exerts any particular influence on the behaviour of the radiating elements with respect to characteristic impedance, velocity of propagation, and "stray" base capacity, as discussed in the preceding sections.

Thin wire aerials supported by wooden masts and terminated in end capacities have been in use for some years. Typical examples are those used at Breslau<sup>(27)</sup> and Copenhagen.<sup>(10)</sup> The latter has been the subject of special study by Prof. Pedersen, who has published data showing that:

- (a) The velocity of propagation along the aerial is practically identical with that in air;
- (b) The current distribution between base and current loop coincides closely with that given by the transmission line theory of Part I of this paper;
- (c) The current distribution is also given with very fair accuracy if we assume the aerial to behave as a lossless transmission line with the whole radiation resistance inserted in one lump at the current loop, for the case when the aerial characteristic impedance is high, i.e., of the order of 500 ohms upwards.

In the particular case studied by Prof. Pedersen the aerial was 125 m. high with a radius of 0.75 cm., and with a capacity termination equivalent at the operating wavelength of 255 m. to 23 m. of aerial wire, giving  $Z_0 = 530$  ohms;  $H/\lambda = 0.49$ ;  $\frac{b}{\lambda} = 0.091$ ;  $R_r = 60.6$  ohms.

In considering the power dissipation in the aerial a loop loss resistance of 9.6 ohms was allowed, making the total loop resistance 70 ohms. The measured ratio of nodal/loop current was about 12 per cent., as compared with the calculated ratio of about 13 per cent., and contrasted with the 25 per cent. ratio found with aerials of low characteristic impedance. If the polar radiation diagram is computed it can be seen the smaller ratio of nodal to loop current (i.e., the closer approximation to "lossless" current distribution) is reflected in the more definite appearance of a radiation minimum between the major and minor radiation lobes.

In the case of Breslau the aerial was 140 m. high, operating on a wavelength of 325 m., and a capacity termination equivalent at the operating wavelength to 42 m. of aerial, giving  $H/\lambda = 0.43$ ,  $b/\lambda = 0.13$ . The measured figure of merit at full power (60 kW) was 347 mV/m. for 1 kW at 1 km. The radius of non-fading reception was about 106 km. as compared with 80 km. for an aerial of the quarter-wave type.

#### (26) *Earth Systems*

In considering the earth system it is necessary to remember that this has two distinct functions: (a) to provide a low resistance return path for the current in the aerial, and (b) to ensure that the earth in the immediate neighbourhood of the aerial really does act as a perfect reflector. The first function directly affects the radiation efficiency of the aerial, but not the form of the radiation polar diagram, i.e., the relative distribution of the power radiated between "sky" and "ground" zones. The second function does not affect the efficiency of radiation, but does affect the polar diagram and, therefore, the anti-fading properties of the aerial.

When the aerial is low ( $\frac{H}{\lambda} \leq 0.25$ ) the current maximum occurs at the base of the aerial, and the earth current density is clearly a maximum near the base. Under these conditions the resistance effect is the dominating one, and the earth network must be designed to take care of high current density near the mast. Experience has shown that with a liberal buried network, extending out from the base of

the aerial and the ground projection of any horizontal portion of the aerial by a distance equal to the height of the supporting masts, the earth resistance on medium wavelengths (200 m. to 550 m.) is likely to be between five and ten ohms, while on the long wave broadcasting band (1 000 m. to 2 000 m.) the resistance is reduced to between two and five ohms. It was on this basis that the figure of 10 ohms dead loss was quoted in section (6).

With high aerials ( $\frac{H}{\lambda} = 0.4$  to 0.6) the current loop is raised well above the base, the earth currents corresponding to this current maximum are well out from the base, and the earth current density over a radius of say a quarter wavelength from the base of the aerial remains fairly constant; the buried network is, therefore, used more efficiently. But it is clear that earth currents of considerable magnitude must exist well beyond the quarter-wavelength radius, and unless the ground conductivity is known to be good it is worth while extending the buried network to a radius of a half-wave-

length, if only to avoid joulean losses in the earth.

Turning to the question of earth reflection as it affects the polar diagram and anti-fading properties of the aerial, the important sky wave radiation which we desire to suppress is roughly that between the zenith angles of zero and  $45^\circ$ . All the contributions to radiation within this zone arising from the current elements at different aerial heights are partly directly radiated and partly reflected from points on the earth surface within the area covered by a radius equal to the aerial height. Unless this area reflects the radiation with unchanged amplitude and phase, we do not get the cancellation between direct and reflected radiation which is responsible for the reduction in sky radiation and extension of the non-fading radius expected from high aerials. As pointed out in section (12), it is not at all clear how an earth with any finite conductivity can reflect in the required manner; but experience shows that, provided the conductivity is high, radiating systems do behave in accordance with the

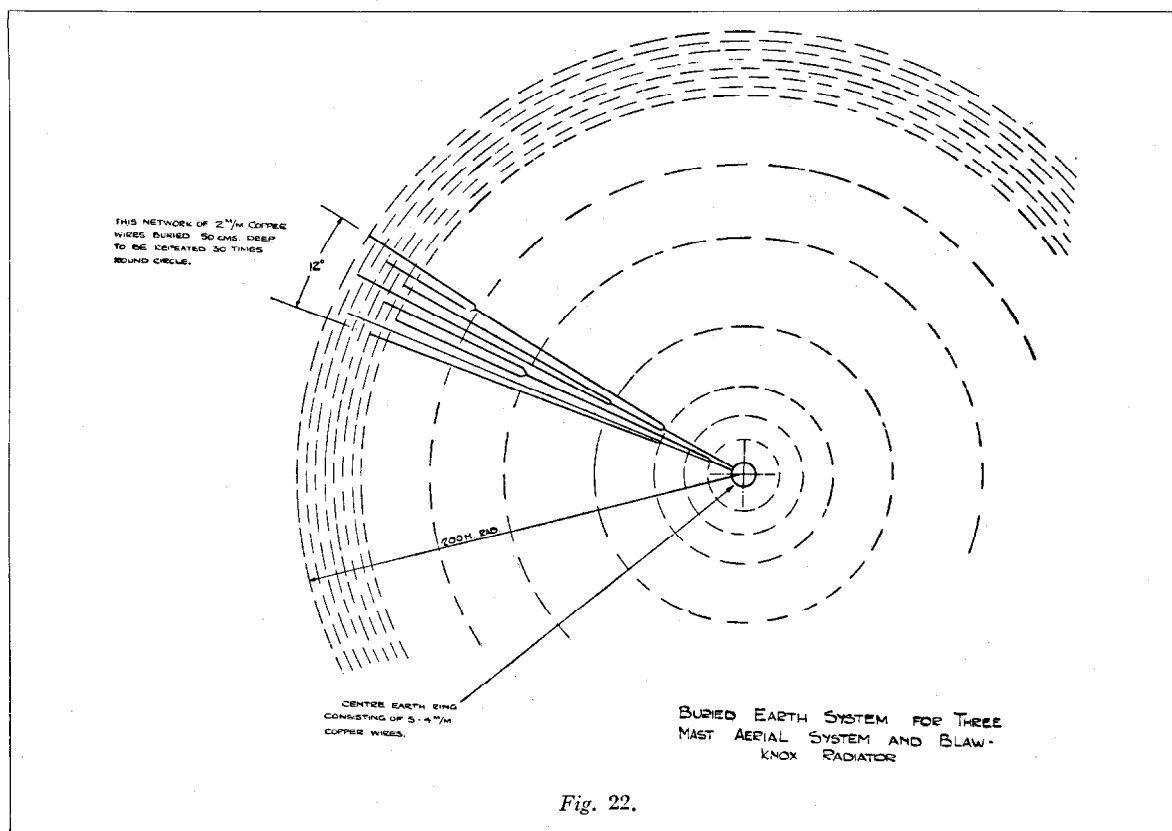

Fig. 22.



“perfect reflection” theory. It is, therefore, necessary that everything possible be done to ensure high conductivity of the ground included in the area mentioned above if we are to obtain the anticipated sky-wave reduction, and for this reason, quite apart from the joulean losses, it is advisable to provide a buried earth network extending out to a radius of half a wavelength when the anti-fading properties of the aerial are important. This is particularly the case with the shorter waves, say below 350 m.; on wavelengths of 450 m. and above, given a good site, i.e., one of naturally low earth resistivity, the radius of the earth network can be somewhat reduced. In the case of Budapest, where the earth resistivity is exceptionally low, operating on a wavelength of 550 metres, with an  $H/\lambda$  ratio of 0.56, excellent anti-fading results were obtained with an earth system of 180 metres radius, or one-third of a wavelength. Fig. 22 shows the general form taken by the earth network in this case.

Exactly the same argument applies to the low angle radiation, except that in this case the radius of the reflecting area involved is enormously greater, and the effect of perfect reflection is to give addition rather than cancellation of the direct and reflected components of radiation. Since the reflecting area is so very much larger it is obviously impossible to reinforce it by a metallic network, and the horizontal radiation must be considered as influenced mainly by site conditions rather than by any earth system which can be supplied artificially, apart from considerations of overall radiation efficiency as affected by ohmic resistance in the path of the earth currents. If the site conditions are not good the horizontal radiation will be decreased and, even with a good buried earth taking care of the sky-radiation, the ratio of sky-field to ground field will be abnormally high and the anti-fading radius correspondingly decreased; while, if the earth system is limited, the combination of no-cancellation in the sky radiation and little reinforcement in the horizontal radiation may result in very disappointing performance. It is believed that factors such as these have been largely responsible for the poor results obtained in one or two cases with high mast aerials.

The value of an extensive earth system is

illustrated by the figure of merit data given by Chamberlain and Lodge.<sup>(23)</sup> They quote for aerials of  $H/\lambda = 0.5$  to  $0.6$  an average of 335 mV/m. at 1 km. for 1 kW input, using an earth radius of a quarter wavelength, increased to 440 mV/m. with earth radius increased to a half wavelength; this corresponds to an increase of station power of no less than 70 per cent.

With regard to the value of dead loss resistance to be used in connection with high aerials, it seems that the value of 10 ohms originally mentioned is probably an outside figure. In quite a number of instances the measured figure of merit corresponds to two ohms or even less and, in the case of Budapest, the earth network of which is rather smaller than would normally be recommended nowadays, the dead loss appears to be about five ohms. If then the figure of ten ohms is used for the dead loss resistance in terms of the loop current, it is unlikely that any over-estimate of field strength will be made.

#### (27) *General Deductions from Measurements*

Combining the data discussed in sections (20) to (26), the following broad conclusions are reached:

- (A) For uniform aerials of wire or mast type, and for cigar-shaped masts operated in the region  $H/\lambda = 0.4$  to  $H/\lambda = 0.6$ , the velocity of propagation along the aerial is substantially the same as in air;
- (B) For the same cases, the current distribution is given with sufficient accuracy for practical purposes by the dissipative transmission line theory outlined in Part I;
- (C) For the same cases, the polar diagram can be calculated using the method given in section (16);
- (D) For the same cases, the figure of merit can be determined from the polar factors calculated as in section (16), and the radiation resistance given by Table III in section (7), taking the loop dead loss resistance as 10 ohms;
- (E) In the case of self-supported towers there is insufficient data to enable any statement to be made as to whether or not the same treatment can be applied as in A, B, C and D above;

- (F) The base impedance can be calculated very closely in the case of thin wire aerials from the dissipative transmission line theory;
- (G) In the case of mast aerials the base impedance can be estimated as regards the magnitude of its resistance and reactance components from the dissipative transmission line theory, but it is necessary to correct the values so calculated to include the effect of the capacity shunt due to the proximity of the mast base to earth, and the reactance of the earth system. There is still not sufficient data to enable this correction to be calculated, but as a first approximation use may be made of the base impedance curves of Figs. 14, 15, 16, 19 and 21.

#### Acknowledgments

It is inherent in a paper of this description that it involves extensive reference to other sources. Moreover, while much of the material dealt with is original so far as the author is concerned, it has been found to have been duplicated and published by others. Where such publication has been found it has been indicated through the cited Bibliography, but the literature on the subject is so extensive and scattered that no attempt has been made to assign priority. In the more important cases direct acknowledgment of the source of information has been embodied in the text.

#### BIBLIOGRAPHY

- (1) G. W. O. HOWE : "Capacity of Radiotelegraphic Antennae," *Electrician* 1914, Vol. 73, p. 829.
- (2) G. W. O. HOWE : "Potential Difference and Capacity in A.C. Problems," *Experimental Wireless*, 1928, Vol. 5, No. 54, p. 113.
- (3) F. W. G. WHITE : "Propagation of Radio Frequency Currents along a Wire of Finite Length," *Proceedings of the Cambridge Philosophical Society*, 1932, Vol. 28, p. 356.
- (4) E. B. MOULLIN : "The Radiation Resistance of Aerials whose Length is Comparable with the Wavelength," *Journal I.E.E.*, 1936, Vol. 78, p. 540.
- (5) E. SIEGEL and J. LABUS : "Radiation Resistance of Aerials," *Hochfrequenz Technik und Elektroakustik*, 1934, Vol. 43, p. 166.
- (6) A. A. PISTOLKORS : "Radiation Resistance of Beam Antennae," *Proc. I.R.E.*, 1929, Vol. 17, p. 562.
- (7) B. VAN DER POL : "Wavelength and Radiation of Loaded Antennae," *Proc. Phys. Society*, 1917, Vol. 29, p. 269.
- (8) G. W. PIERCE : *Electric Oscillations and Electric Waves*, 1920, McGraw Hill Book Co., Inc.
- (9) STUART BALLANTINE : "On the Radiation Resistance of a Simple Vertical Antenna at Wave Lengths below the Fundamental," *Proc. I.R.E.*, 1924, Vol. 12, p. 823.
- (10) P. O. PEDERSEN : *Radiation from a Vertical Antenna over Flat Perfectly Conducting Earth*, Danmarks Naturvidenskabelige Samfund, on commission by G. E. C. Gad, Copenhagen.
- (11) C. B. FELDMAN : "Optical Behaviour of the Ground for Short Radio Waves," *Proc. I.R.E.*, 1933, Vol. 21, p. 764.
- (12) J. A. RATCLIFFE ; L. G. VEDY, and A. F. WILKINS : "The Spreading of Electro-Magnetic Waves from a Hertzian Dipole," *Journal, I.E.E.*, 1932, Vol. 70, p. 522.
- (13) F. HOLLAND ; C. E. STRONG and F. C. MCLEAN : "The Budapest Anti-Fading Antenna," *Electrical Communication*, 1934, Vol. 12, p. 289.
- (14) E. A. LAPORT : "Increased Efficiency from Tower Antennas," *Electronics*, 1934, August, p. 238.
- (15) C. P. STEINMETZ : *Theory and Calculation of Transient Electric Phenomena and Oscillations*, 1920, McGraw Hill Book Co., Inc.
- (16) E. JAHNKE and F. EMDE : *Tables of Functions*, 1933, Teubner, Berlin.
- (17) W. L. BARROW : "On the Impedance of a Vertical Half-Wave Antenna above an Earth of Finite Conductivity," *Proc. I.R.E.*, 1935, Vol. 23, p. 150.
- (18) STUART BALLANTINE : "High Quality Radio Broadcast Transmission and Reception," *Proc. I.R.E.*, 1934, Vol. 22, p. 564.
- (19) HANS RÖDER : [Discussion on Item (18) above]. *Proc. I.R.E.*, 1935, Vol. 23, p. 256.
- (20) H. E. GIHRING and G. H. BROWN : "A Brief Survey of the Characteristics of Broadcast Antennas," *Broadcast News*, 1934, December, p. 4.
- (21) H. E. GIHRING and G. H. BROWN : "Tower Antennas for Broadcast Use," *Proc. I.R.E.*, 1935, Vol. 23, p. 311.
- (22) J. F. MORRISON and P. H. SMITH : "The Shunt-Excited Antenna," *Proc. I.R.E.*, 1937, Vol. 25, p. 673.
- (23) A. B. CHAMBERLAIN and W. B. LODGE : "The Broadcast Antenna," *Proc. I.R.E.*, 1936, Vol. 24, p. 11.
- (24) W. BERNDT and A. GOTHE : "The Vertical Polar Diagram of High Aerials for Broadcasting," *Telefunken-Zeitung*, 1936, Vol. 17, No. 72, p. 5.
- (25) A. J. MCKENZIE : "Developments in Broadcasting Aerials," *Telecommunication Journal of Australia*, 1936, No. 3, p. 58.
- (26) R. A. TURNER : "Grafton N.S.W. Radiator : Some Aspects of Design, Construction and Erection," *Telecommunication Journal of Australia*, 1936, No. 3, p. 63.
- (27) F. EPPEN and A. GOTHE : "Anti-Fading Aerial of Breslau Broadcasting Station," *Elektrische Nachrichten Technik*, 1933, Vol. 10, p. 173.

# Broadcasting Station LS-1—Buenos Aires

By R. E. CORAM,  
*Bell Telephone Laboratories,*

A. W. KISHPAUGH,  
*Bell Telephone Laboratories,*

and

W. H. CAPEN,  
*International Telephone and Telegraph Corporation*

**B**ROADCASTING station LS-1 of the Municipality of Buenos Aires, Argentina, has been operating since early in 1927 with a type 104, 5-kW transmitter built by the Western Electric Company. The sterling service obtained from that equipment during ten years has been the chief factor influencing the decision, in April 1937, for the replacement of the old equipment by a 50-kilowatt Western Electric transmitter, to be installed by Compañía Standard Electric Argentina, a subsidiary of the International Standard Electric Corporation.

Located near the suburban town of Monte Grande, about twenty miles in a south-westerly direction from the city of Buenos Aires, the new transmitter is housed in a two-storied building of strictly modern lines, half of this building being occupied by the living quarters for the resident station chief. Heat from the water-

cooling system of the power tubes is dissipated by a spray pond via a set of inter-coolers. Owing to the high efficiency obtained in the transmitter, the spray pond itself is only called upon to dissipate about 55 kW, permitting the use of a relatively small, well-proportioned fountain which serves as a decorative *motif* for the front of the building.

The station is the property of the Municipality of the city of Buenos Aires and is operated under the administration of the Colon Theatre, which is one of the world's finest opera houses, where the pick of the world's artists are heard each season. There are sixteen or seventeen hours of transmission daily with a varied programme of entertainment of widely international flavour, and of cultural and educational subjects. However, the main attraction of LS-1, and its outstanding and unsurpassable feature, has

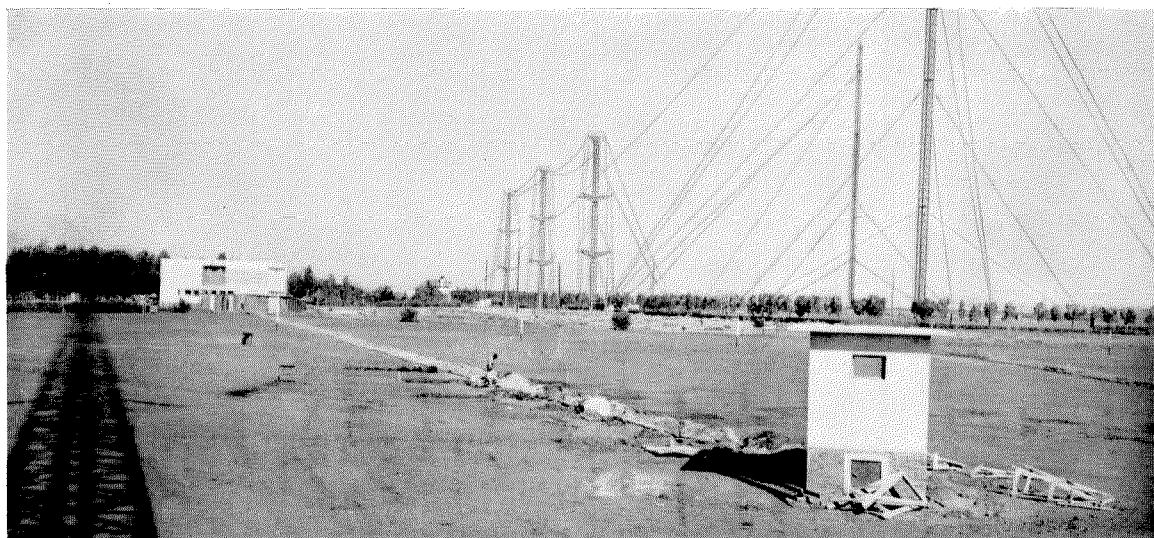

Fig. 1—General View of LS-1 Showing Transmitter Building, Coupling House and Transmission Line Trench.

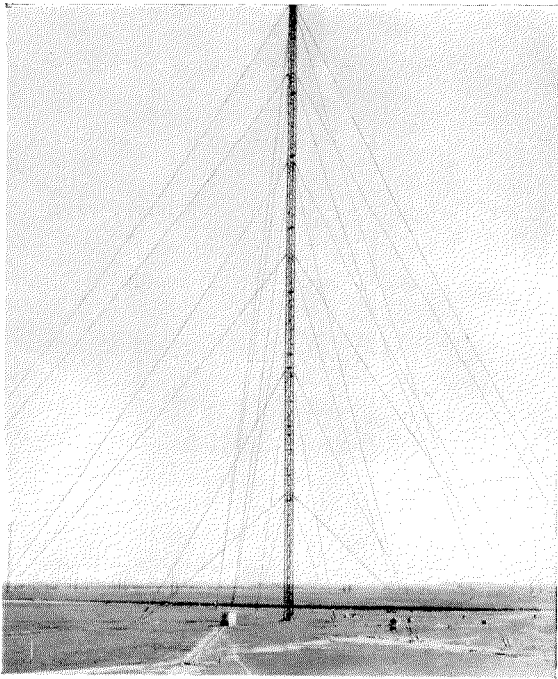

Fig. 2—Shunt-Excited Grounded Radiator.

always been the complete transmission of the opera and other musical activities of the Colon Theatre. These transmissions, supplemented during intervals by well-informed commentaries on the work being performed, bring great music by first-rate performers into the homes of listeners almost nightly throughout the season. The new equipment, with its greater power and more efficient radiation system, makes these programmes available to the great majority of the population of Argentina as well as to listeners in Chile, Uruguay and Southern Brazil.

The Colon season, formally opened this year by the President of the Republic in a grand gala performance on 23rd May, usually lasts about six months. A wide repertory of classic Italian, German and Russian opera is usually presented with a sprinkling of modern Argentine works. The latter end of the season is taken up with ballets and concerts of symphonies and choral works. During the

summer months concerts and ballets are given in the open air on a stage set with natural scenery.

Interest in the musical performances at the Colon Theatre is not limited to a select few, but is widespread throughout a comparatively large section of the population. Their popularity is augmented by being regularly heard on the air.

This new station, a general view of which is shown in Fig. 1, was inaugurated on 22nd May, 1938, and covers all the more densely populated districts of Argentina. It incorporates the high efficiency Doherty amplifier, the total load on the mains being only 140 kW with full output and average programme modulation, and 125 kW when no modulation is applied.

The antenna shown in Fig. 2 is a shunt-excited grounded radiator 778 feet high (0.56 wavelength); it is the tallest broadcast antenna in South America and the highest of its kind anywhere. It is also the first vertical radiator in South America, using the shunt excitation method developed by the Bell Telephone Laboratories. The ground system consists of one hundred and twenty buried radials, each 670 feet long, with an equal additional number of radials 280 feet in length. Power is fed on to the antenna system via a 62 ohm nitrogen gas filled, concentric copper tube transmission line with a total length of 640 feet. A similar line, with an electrical length of a quarter wavelength short circuited at the extreme end, is used to prevent radiation of the second harmonic. This is additional to the regular harmonic filter in the transmitter. Both these lines have been buried in a trench with a specially prepared base of

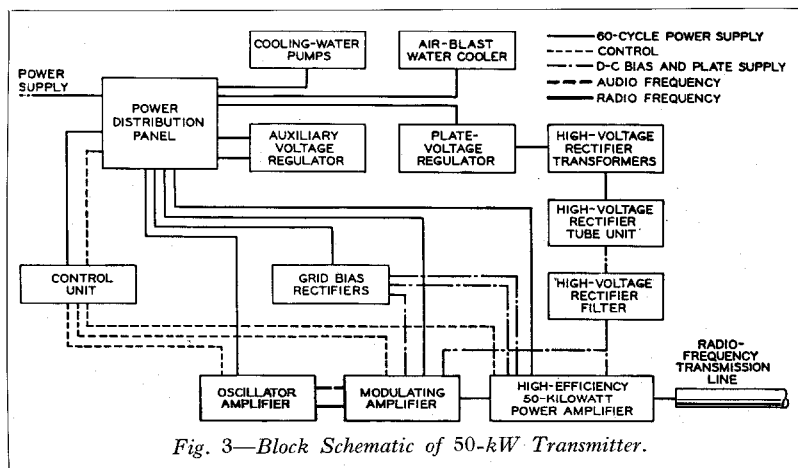

Fig. 3—Block Schematic of 50-kW Transmitter.

wood planks and fine sand, necessary due to the nature of the soil.

An interesting addition to the shunt-fed radiator is the provision for relative readings at the transmitter itself of the actual current circulating in the radiator. This is effected by mounting a pick-up loop at a convenient point on the antenna and taking the induced radio frequency back to the transmitter via a special flexible concentric cable. This cable is carried, together with the gate interlock for the coupling house and other control circuits, in a conduit laid alongside the transmission line, the corrosive nature of the soil making compound treatment of its surface necessary.

Visitors to the station, especially those technically interested, have all expressed a favourable impression of the greatly reduced size of the equipment, as compared with previous designs of the same power rating, without overcrowding or sacrifice of accessibility. This has been made possible by careful design and by

the great advance in efficiency, which allows a lighter mains plate supply equipment to be employed.

The studios and studio equipment have also been completely replaced. The new and ample studios, built below ground level close to the Colon Theatre, are completely sound-insulated. All facilities for control, etc., have been provided.

The new broadcasting station is equipped with the latest Western Electric 50-kilowatt transmitter, which has been coded the No. 407-A. Although the use of fifty kilowatts for broadcasting is no longer a novelty, this new equipment presents such a number of features of importance that the progress represented is comparable to that which aroused interest when the first Western Electric fifty-kilowatt transmitter was being tested by the Bell Telephone Laboratories at Whippany, New Jersey, U.S.A., in 1927. While the achievement at that time was principally in the utilization of increased power, the present advancement is in refinement of trans-

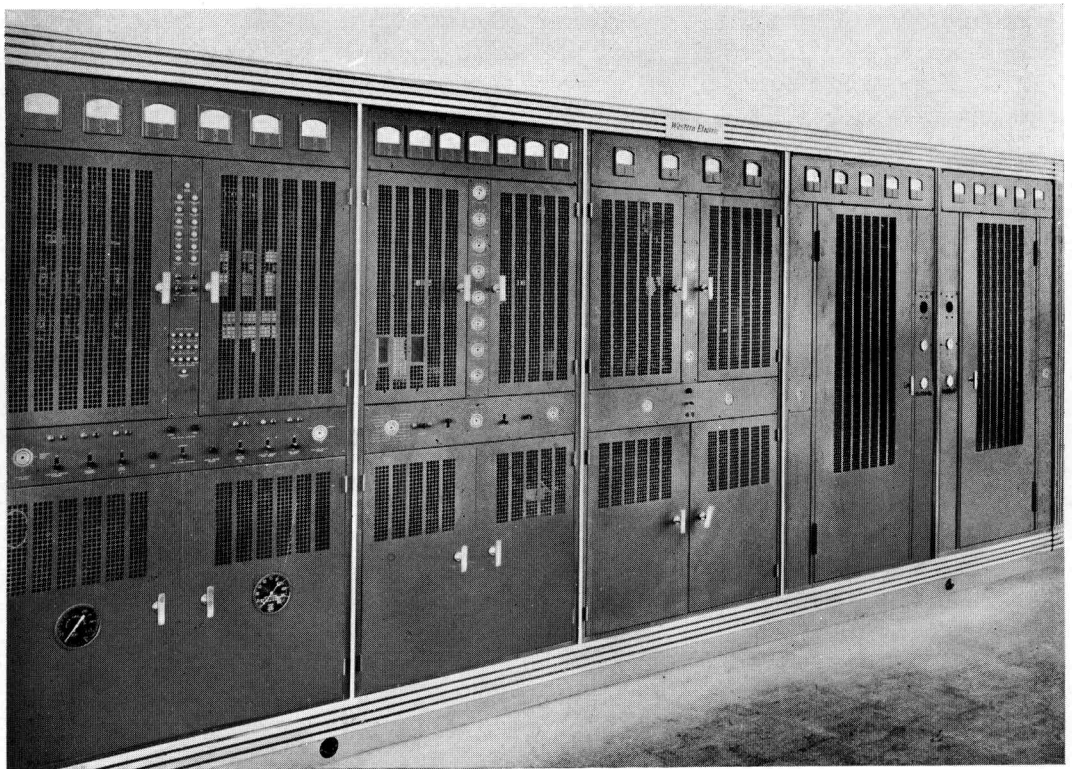

Fig. 4—Audio and Radio Frequency Units of 50-kW Transmitter.

mitter design to give improved performance, and more efficient, more reliable, and more economical operation.

An outstanding feature of the new equipment is the use of the high-efficiency amplifier circuit invented by W. H. Doherty of the Bell Telephone Laboratories. By the use of this circuit in the final amplifier stage, the power consumption of the transmitter has been greatly reduced, the plate losses in the power amplifier being cut from nearly 100 to less than 30 kilowatts. Among the other features that make the transmitter outstanding in its class are the use of stabilized feedback to minimize noise and distortion, complete A.C. operation to eliminate motor generators for filament current and grid bias voltages, two 100-kW tubes in the final stage instead of, as formerly, six smaller ones, complete remote control of all power circuits, automatic regulators for plate and biasing supplies, and individual control of the filament voltages of the power amplifier.

The equipment of the 50-kW transmitter is indicated in Fig. 3. The audio and radio frequency circuits are included in four units arranged as a line of cabinets, as shown in Fig. 4. At the left is the control unit where the operating control of the entire equipment is centred. Here are toggle switches that operate contactors on the power-distribution panel for all circuits, and pilot lamps that indicate circuit conditions and sources of interruption. The second unit is the oscillator amplifier, which includes the oscillator and three radio-frequency amplifier stages, and the entire audio-frequency circuit. The next unit is the modulating amplifier. It includes two tubes operated in parallel with grid-bias modulation. The output of this section drives the 50-kW amplifier, which forms the final unit. Here are two 100-kW tubes operated in a Doherty high-efficiency circuit. The appearance of this section, with its two doors open, is shown in Fig. 5.

Besides these four major units there is the power and rectifying equipment, the component parts of which are usually installed in an enclosure behind the cabinets or on the floor below. All the power required for the transmitter is taken from a 460-volt, three-phase supply, which is carried directly to the power

distribution panel. No fuses are employed; all circuits are protected by circuit breakers, and power for the various circuits is switched through contactors operated from the control unit. All the power except that for the pumps and fans of the water-cooling system is regulated to secure constant voltage. Two automatic regulators are employed. One of them supplies the high-voltage transformers for an 18 000-volt rectifier that furnishes plate potential for the power and modulating amplifiers. The other feeds a bus in the distribution panel from which circuits are taken for the oscillator-amplifier units, for filament supplies for the other amplifier units, and for three bias rectifiers for the modulating and power-amplifier stages.

It is very desirable to have the major units of a broadcast transmitter so designed that they will serve as building blocks from which various sizes of transmitters may be assembled. This enables a station to start with a low-power transmitter and increase its output from time to time with a minimum of expense. This principle has been followed in the design of this 50-kW transmitter.

The first three units of this transmitter are essentially the 5-kW Doherty transmitter (see Fig. 6). The smaller size of the modulating amplifier of the 5-kW transmitter, however, permits it to be included in the oscillator-amplifier unit, which becomes the driving unit. The 5-kW power amplifier occupies the third cabinet, the final one of the 5-kW transmitter.

Mounting space is provided for two 702-A oscillators, both of which are kept at the operating temperature at all times. A small switch adjacent to them permits either to be switched into the circuit at a moment's notice. With all possible variables changing in the same direction at once, the frequency deviation is much less than ten cycles which, although it is the guaranteed deviation for the transmitter, is only one-fifth of the usual fifty-cycle requirement. The oscillator is provided with a fine adjustment so that the frequency can be set to agree exactly with the frequency monitor or with any other reference standard. Space is provided adjacent to the oscillator to permit the required synchronizing apparatus to be installed if the transmitter is to be made part of a synchronized system.

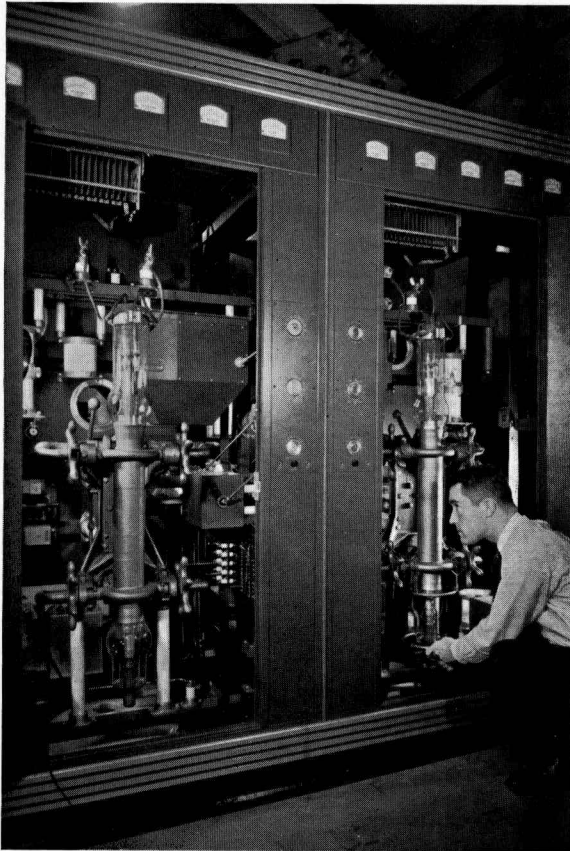

Fig. 5—50-kW Amplifier.

Another interesting feature of the transmitter is the use of straight porcelain piping, glazed inside and out, as the insulating connection for the cooling water supply for the 5-kW and 50-kW amplifier tubes. Formerly these connections have been either unsightly rubber hose or a coil of ceramic tubing, which is not glazed on the inside and is difficult to clean on the outside.

Continuity of service is increasingly important in the operation of broadcasting stations, and to some extent becomes of greater importance as the size of a station increases. In this new 50-kW transmitter, therefore, every effort is made to avoid shutdowns by giving warning of approaching failure, and by reducing to a minimum the time off the air when an interruption does become necessary.

One of the features designed to reduce loss of time is the use of a protective circuit, described in the *Bell Laboratories Record*.\* It operates

on any type of disturbance in the output circuits and removes the radio frequency power until the trouble has cleared itself—usually only a small fraction of a second. This prompt removal of power avoids the serious damage that might otherwise result from heavy currents, and reduces the time off the air to inappreciable intervals. An important feature of this circuit is a meter that indicates continuously the state of circuit adjustment, and in some cases gives warning of approaching trouble.

Another added feature of the 50-kW transmitter is the provision of a seventh, or spare, rectifier tube in the rectifier for the power amplifier. This tube may be rapidly substituted for any of the others without removing it.

Arc-backs are infrequent with modern rectifier tubes. When they do occur, they are quickly cleared by a very fast circuit breaker in the main feeder to the rectifier. This breaker automatically recloses once after it opens and thus makes the interruption so short as to be unnoticeable. At the same time arc-back relays give an indication of the particular tube in which the arc-back occurred. Another safeguard is the provision of three single-phase transformers for supplying this rectifier. Two of them in an open-delta connection will carry the load, and thus any one of the three transformers may be considered as a spare.

With the same general objective, many protective circuits are included in the control unit to ensure continued operation by giving warning of dangerous conditions and controlling the sequence of the operating procedures. Among these are electrical interlocks to prevent the application of power in the wrong sequence, the automatic reduction in the rectifier voltage before starting, and flow meters in the cooling water system that will give an alarm and, if necessary to avoid damage, will remove power immediately from the water cooled tubes.

Tuning for the high-efficiency Doherty amplifier is easily checked by the aid of a cathode-ray oscilloscope, which can be connected by plugs and jacks to the plates and grids of the two 100-kW tubes. When correctly adjusted, the grid potentials of the two tubes are approximately  $90^\circ$  apart, and will show a vertical ellipse on the oscilloscope as shown at the left of Fig. 7. The dotted ellipses indicate

\**Bell Laboratories Record*, March, 1938, p. 254.

improper adjustment on either side of the correct one. Between plate and grid, the phase relationship is  $180^\circ$ , and the pattern for correct adjustment is a diagonal line. When the phasing is not correct, the line widens to an ellipse.

The performance of this new 50-kilowatt transmitter is of the high order required of modern broadcasting equipment. From the broadcaster's standpoint, the economy and ease of operation experienced will set new standards. From the standpoint of transmission, little further improvement can be visualized. Through careful circuit design and with the benefits of negative feedback, the audio-frequency characteristics approach perfection. The audio-frequency response does not vary more than one decibel between 30 and 10 000 cycles. The audio distortion at complete modulation will not exceed 5 per cent. over the 50 to 5 000 cycle range, and is very much less in the middle frequencies, or over the entire range with average modulation. The carrier noise is negligible, being more than 60 decibels below the signal at 100 per cent. modulation.

As previously mentioned, the transmitter is designed to be flexible as regards power, and it is interesting to note that the driving unit alone

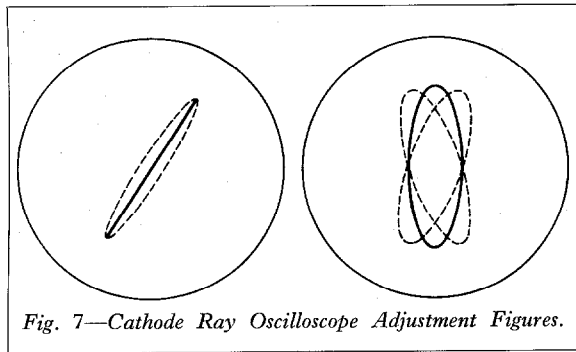

Fig. 7—Cathode Ray Oscilloscope Adjustment Figures.

may be arranged to serve as a complete 100-watt transmitter. Provisions are also made for increasing the output of the 50-kW transmitter to 500-kW by the addition of a 500-kW amplifier. In each case certain circuit and equipment changes are necessary, but by careful design the changes have been reduced to a minimum, and the flexibility provided does not impose any economic penalties on the purchase of any one size. Besides these arrangements for increasing the power of the transmitter, provisions have also been made to permit the transmitter to operate at reduced power during certain hours of the day or under emergency conditions. The minor modifications required depend for the

most part on the particular conditions to be met.

The results and performance of the new LS-1 station have more than equalled expectations, and many complimentary comments have been made in the broadcasting and musical circles of Buenos Aires both because of the high quality of its programmes and because of the revolutionary design of the equipment, which marks one more step forward in the annals of local broadcasting, and gives Buenos Aires the most modern station, with quality and performance worthy of the high standards of the Colon Theatre.

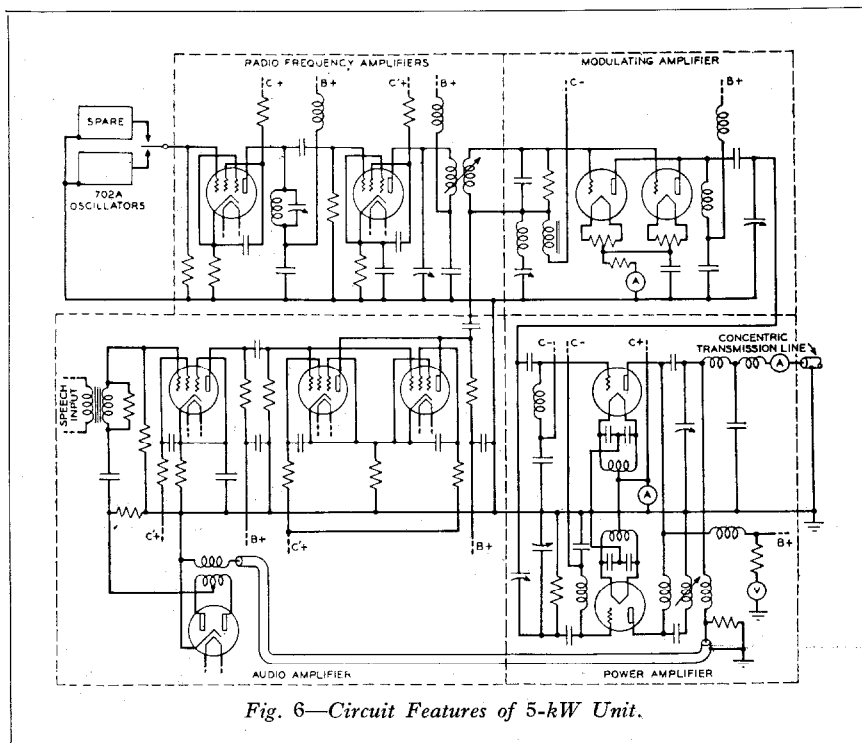

Fig. 6—Circuit Features of 5-kW Unit.



# Recent Progress in Automatic Ticketing in Belgium

By J. A. MARCHAL,

*Ingénieur en Chef—Directeur Régional, Circonscription Téléphonique, Brussels,*

and

G. E. H. MÖNNIG,

*Ingénieur en Chef—Directeur Adjoint, Circonscription Téléphonique, Brussels*

WHEN the possibility of handling toll telephone traffic automatically in Belgium was first examined, one of the main problems which arose was the method to be adopted for charging subscribers' calls. Multiple metering, the system hitherto adopted in other countries, may be satisfactory from a technical point of view, but is necessarily incomplete inasmuch as it offers no information as to the number of connections made, their destination, or their duration. The records produced by this method being essentially in the nature of aggregates of chargeable units over a given period, the subsequent separation of the records into their constituent elements, in the event of a question or for a statistical study, is impossible.

On the other hand, the call-ticket which is prepared for every call in manually operated toll service provides valuable information, not only from an exploitation point of view, but also for the eventual satisfaction of the subscriber. It is consequently logical that, concurrently with the substitution of automatic for manual switching methods, engineers should have set themselves the task of producing, by automatic means, all the particulars hitherto associated only with manual service. The Bell Telephone Manufacturing Company of Antwerp has achieved this result by the use of printing registers incorporated in the system known as "Automatic Ticketing."

A technical description of this system appeared in a previous issue of *Electrical Communication*.<sup>1</sup> It is not the present intention to elaborate this aspect, but rather to record some of the results of the field trials of the system carried out by the Belgian "Régie des

Télégraphes et des Téléphones" and to outline some further developments which have been and are to be introduced in the national telephone network.

## *Trial Installations in the Bruges Zone*

In the first instance, Automatic Ticketing was applied to the traffic from Bruges to Blankenberghe, the new equipment having been cut over early in December, 1936. Certain junction lines were set aside to deal exclusively with this traffic and, with each of these junctions, a printing register<sup>2</sup> was permanently associated at the Bruges end. For the traffic in the opposite direction, that is, from Blankenberghe to Bruges, the multiple metering system, in service since 1934 with two message registers for every subscriber, was retained.

Subsequently, it was decided to extend the system to include the traffic from Bruges to four other towns in the Bruges zone and vice-versa, and also the multi-fee traffic between these towns.<sup>3</sup> All the printing registers for the new services were concentrated in the Bruges exchange, the switching centre of the zone, thereby creating the new problem of identifying a calling subscriber from a distant exchange.

The use of a special group of junctions outgoing from Bruges for calls requiring printing registers has been abandoned; each of the outlying exchanges is now connected to Bruges by but two junction line groups, one for each direction of traffic. The lines converging on Bruges carry, in addition to automatic ticketing traffic, other classes of traffic, such as calls to "special services" and transit calls between certain of the outlying exchanges not requiring

<sup>1</sup>"Automatic Ticketing of Telephone Toll Calls," by L. B. Haigh, *Electrical Communication*, April, 1937.

<sup>2</sup>"Automatic Printing Register for Telephone Call Recording," by L. Devaux, *Electrical Communication*, April, 1937.

<sup>3</sup>*Electrical Communication*, October, 1937, page 180.

a printing register. The equipment at the outlying exchanges thus had to be designed so that a signal could be sent to the zone centre exchange to call for a printing register only when one was needed. The lines radiating from Bruges carry manually established toll connections as well as traffic with automatic ticketing.

The printing registers are accordingly no longer permanently associated with individual outgoing junction lines; they are now more economically assembled in a single common group and any one of them can become connected, automatically, to any incoming junction line, or, in the case of calls originated in Bruges, any second group selector. By this means, the number of printing registers installed at the zone centre exchange is reduced to a minimum.

Two of the four new offices of the second stage were completed at the beginning of June 1937, at which time of year the traffic reaches its maximum, and the Régie was thus able to carry out its field trials under the most severe service conditions likely to be encountered.

In November, 1937, two more outlying exchanges were cut over, bringing the total number of subscribers' lines in service with automatic ticketing facilities at the end of the year to 5 400.

#### **Results of Field Trials**

The operating results for the period from July 1 to September 15, 1937, show that there was a total of some 62 000 calls from these lines for which tickets were needed. Of these, the number of calls which either could not be charged or were wrongly charged, due to the ticket bearing incomplete or incorrect details, was 80; that is, 0.13% of the whole.

It may be mentioned that 50% of the total number of failures reported were due to faulty printing of the ticket serial number, which serves only as a check on the number of tickets produced, a duty which could be preformed equally well by an ordinary message register. The Régie accordingly decided to abandon the serial number and instead to install a message register on every printing register bay.

The trial period is past and the installations which will now be described, and which will be placed in service during 1938, will be

considered as forming part of a comprehensive plan for developing the toll service throughout Belgium.

#### **Automatic Ticketing in Brussels City Exchanges**

At the present time there is a somewhat anomalous situation in the Brussels area, akin to that which existed in the Bruges area before the introduction of automatic ticketing in 1936. Whereas subscribers in the suburbs, who are connected to exchanges of the 7-D Rotary type, are able to dial directly to the city or to other suburbs, city subscribers can as yet dial only to subscribers within the local or single-fee area, that is, within the city sector. For calls going beyond the limits of this sector, a subscriber must avail himself of the services of an operator. Such calls are, however, established on a "C.L.R." basis, without recall of the calling party, so that rapid service is furnished.

It has now been decided to replace the present manual operation by entirely automatic switching, including automatic ticketing instead of multiple metering. In view of the possibilities of extending dial service to the case of toll calls from Brussels to other large cities—possibilities which have been opened up by recent developments, particularly by the automatic ticketing system, and which are now being actively studied—the conversion of the city exchanges will include centralisation of the "special services" and provision for future outlets to a second urban zone and to an automatic toll exchange, as well as to the suburban zone.

One level of the first group selectors—now carrying only the traffic to "special services," most of them localised—will then be used to route these four classes of traffic to a pivotal switching point in the toll exchange where they will separate at intermediate selectors, as can be seen from the routing diagram shown in Fig. 1. Since all the other levels of the first group selectors are already in use, extensive re-routing of local area traffic will thus be avoided.

By centralising in the toll exchange the tariff control circuits and printing registers required for the whole of the 107 000 urban subscribers, it has been found possible to arrange this equipment in large groups and to use the same circuits not only for the traffic to the suburbs

but also, at a later date, for the automatic toll traffic.

**New Method of Identifying the Number of a Calling Subscriber's Line**

The automatic determination or "identification" of the calling subscriber's line, in an originating city office of the 7-A Rotary type, is performed in a novel manner by one of a group of identification control circuits with the aid of a regular final selector. The calling party identification system is included in diagrammatic form in Fig. 1. A signal transmitted from the tariff control circuit TCC causes circuit changes in the outgoing junction circuit at the originating exchange, as a result of which a voice frequency tone of 1 500 cycles is impressed on the "c" brush of the first group selector to "mark" the cord circuit engaged by the call, and the finder

switches of a group of cord control circuits CCC start to rotate. One of these control circuits connects itself to the cord circuit of which the group selector forms a part and impresses a similar tone of the same frequency on the "c" brush of the associated second line finder, whence it is conveyed over a brush of the first line finder to the "c" wire of the calling line.

A finder LIF associated with each of a group of identification control circuits ICC simultaneously starts to hunt. To the arcs of these finders is connected a multiple of 500 wires each representing one of the 10 levels of one of the 50 groups of final selectors which are to be found in a 10 000-line exchange. 100 of these wires are connected to the arc terminals over which each of 5 brushes wipe, so that in one revolution these 5 brushes explore the whole

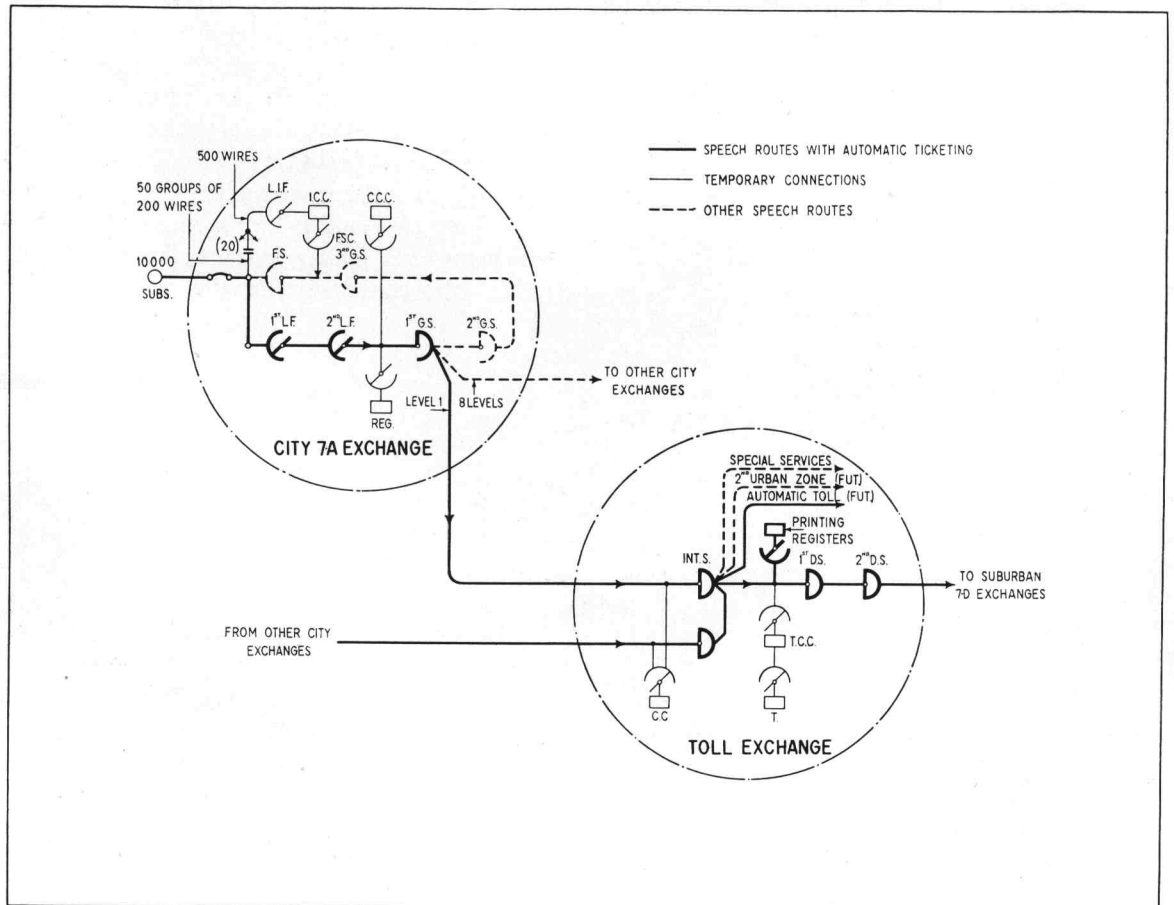

Fig. 1—Routing Diagram illustrating the Introduction of Automatic Ticketing in Brussels.

multiple. It is well known that in the 7-A Rotary system a final selector has access to 20 subscribers' lines on each level; thus each of the above mentioned 500 wires represents a group of 20 subscribers' lines.

Every group of 20 lines is provided with a block of 20 small condensers. On one side, these 20 condensers are joined and connected to the multiple wire representing the group; on the other side, they are connected individually to the "c" wires of the corresponding 20 subscribers' lines. The tone propagated from the cord control circuit, having reached the "c" wire of the calling line over the path already described, passes through the condenser belonging to this line and "marks" one of the 500 arc terminals on the finders LIF.

These finders rotate with a valve detector connected to each of the 5 brushes, and one of them stops as soon as a brush encounters the marked terminal. When this occurs, it will be clear from the foregoing that the position in which the finder has stopped, together with the particular brush over which the marking tone was located, can indicate to the identification control circuit not only in which group of 20 the calling subscriber's line is to be found, but also the group of final selectors which has access to the line and the level on which it appears. If one of these final selectors can now be caused to search on the appropriate level for the line with the "c" wire carrying the tone, the identity of the calling subscriber's line will be completely established.

In order to achieve this result, the second finder FSC of the identification control circuit is caused to choose a disengaged final selector in the appropriate group and the trip spindle of the selector is driven to the position in which it can trip the brushes of the desired level. The brush carriage then rotates, transmitting reverberative impulses in the usual way to the identification control circuit until a valve connected to the "c" brush once more detects the tone. The brushes then stand on the terminals of the calling line itself; the number of impulses counted by the control circuit indicates the "units" digit, and hence completes the identification, of the calling subscriber's line.

Since all 6 digits of the directory number of this line are now identified in the control

circuit from the various indications received, there remains only the problem of transferring them to the printing register in the toll exchange. This operation is performed by transmitting 6 series of A.C. impulses of a different voice frequency from the identification control circuit, via the "c" brushes of the final selector, first line finder and second line finder in turn, to the cord control circuit whence they are repeated, this time by direct current means, via the "c" brush of the group selector to the outgoing junction. In this circuit they are once again repeated and transmitted over the junction, also by direct current means, to the tariff control circuit TCC, where they are finally repeated to the printing register and recorded.

This new system of calling subscriber's line identification, developed by the Bell Telephone Manufacturing Company, is better suited to exchanges of the 7-A Rotary type than is the system consisting entirely of finders, employed in 7-D Rotary exchanges and previously described in *Electrical Communication*. In the first Brussels city exchanges, installed between 1922 and 1924, there are intermediate distribution frames and, even in some of the most recent offices, the subscribers' lines do not always appear in numerical order in the arcs of the first line finders. The application of the principle of identifying a calling line by determining in succession the group of first line finders to which it is connected, and the position of the brushes of the particular first line finder which has been engaged, presents difficulties in such cases. These difficulties do not arise when the line is approached on the final selector, or numerical, side of the frame; the latter method, therefore, has been chosen for all the Brussels city exchanges.

#### ***Automatic Ticketing in Brussels Suburban Exchanges***

As mentioned above, subscribers in the suburbs are already able to dial directly to the city. The eleven existing 7-D Rotary type suburban exchanges, all situated outside the city single-fee area, were provided at the outset with multiple metering equipment and tariff translators for this purpose. Multi-fee calls are recorded upon subscribers' auxiliary message

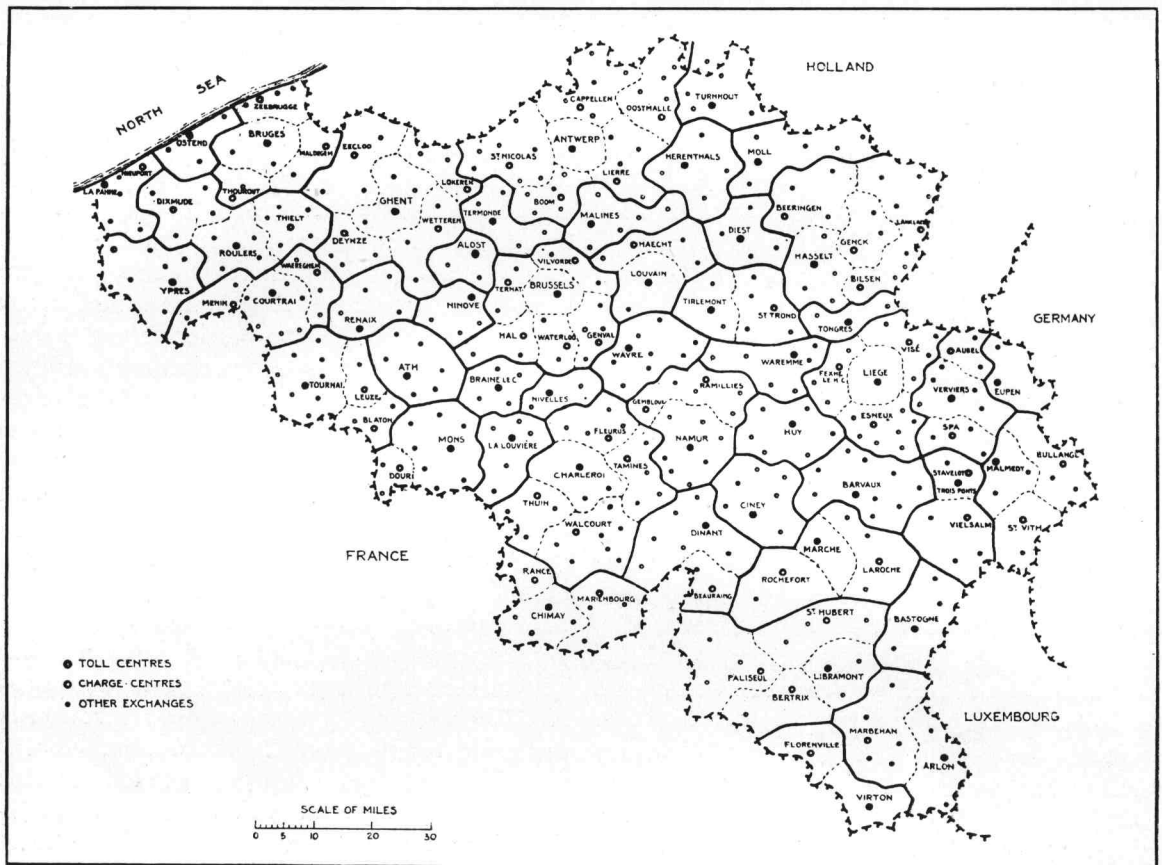

Fig. 2—The Division of Belgium into Zones for National Dialling.

registers, the normal message registers being reserved exclusively for single-fee calls.

A twelfth exchange, now in course of construction, will contain none of these features, since automatic ticketing will be provided instead of multiple metering. The printing registers and the necessary equipment for tariff determination will be centralised in Brussels and, in fact, will be the same as those which are used for calls in the opposite direction, i.e., from the city to the suburbs.

The existence of automatic telephone plant operating on the multiple metering system is thus no bar to the introduction in the same zone of new plant equipped with the more modern automatic ticketing system. It will not be necessary to modify the first eleven suburban exchanges until such time as direct dialling from these exchanges beyond the limits of the Brussels zone is introduced.

### *A Co-ordinated Plan for National Dialling*

It may be well to indicate here briefly some of the steps taken by the Régie with a view to the introduction of automatic toll service throughout the country.

Belgium, which has an area of 11 770 square miles, has been divided into 101 "sectors" of an average area of some 116 square miles, corresponding to a radius of about 6 miles. Any call remaining entirely within a sector is registered by a single operation of the calling subscriber's message register. In other words, such a call is considered as a "local" call and it should be noted that it is made by dialling only the 5 or 6-digit directory number of the desired subscriber. Two to six of these sectors, when combined, constitute an area, which is referred to as a "large zone" to distinguish it from a "small zone" consisting of a single isolated sector.

Any call remaining within a large zone can also be made without the need of dialling more than the desired subscriber's number. On the other hand, in contra-distinction to the case of a call remaining within a sector, a call between subscribers belonging to different sectors of the same zone is charged according to the air-line distance between the "charge-centres" of the sectors in question. The "charge-centre" of a sector is a single arbitrarily chosen point, coinciding usually with the most important central office, and replaces the multiplicity of charge-centres which previously existed, when every town and village in a sector, provided it possessed a central office, constituted a point from or to which charges were computed.

The country, as will be seen from Fig. 2, now comprises 23 large zones with 77 sectors in all, and 24 small zones, a total of 101 sectors with 101 charge-centres, instead of the 450 such points, previously obtaining, corresponding to the 450 central offices. The zone of Brussels consists of 6 sectors, namely, the city sector and 5 others denoted by the charge-centres of Halle, Waterloo, Genval, Vilvorde and Ternath.

Calls between subscribers of different zones will be established automatically by dialling the prefix of the zone to which the desired

subscriber belongs, followed by his directory number. Prefixes consist of 2 or 3 digits, according to whether the directory numbers in the zone comprise 6 or 5-digit numbers, respectively. The first of these prefix digits is always "0."

Thus the total number of digits to be dialled is made uniform and never exceeds 8. Up to the present, only Brussels subscribers have 6-digit numbers. For the whole country there will be 23 + 24, or 47) prefixes in all, corresponding to an equal number of zones.

#### ***Subscriber-to-Subscriber Dialling from One Zone to Another***

The present year will witness the inauguration of new automatic local and toll switching equipment in the town of Malines, which lies midway between the two most important cities in the country. Malines subscribers will be able to dial directly to subscribers in the Brussels city sector, to which the prefix "02" has been assigned, and also to Antwerp city subscribers by using the prefix "031." Automatic ticketing will be employed. This installation will thus constitute the first example of subscriber-to-subscriber dialling from one zone to another in accordance with the above-mentioned national plan.

# National Dialling in the Netherlands

By J. P. VERLOOY,

*Bell Telephone Manufacturing Company, The Hague, Holland,*

and

M. DEN HERTOOG,

*Bell Telephone Manufacturing Company, Antwerp, Belgium*

## Introduction

THE Netherland Governmental Telephone Administration, which controls all telephone lines of the country not connected to the municipal networks of the cities of Amsterdam, Rotterdam and The Hague ('s-Gravenhage), is carrying out a vast programme of automatisisation of its telephone plant. This includes the conversion to automatic operation of all present manually operated local exchanges and the installation of automatic equipment for handling long distance traffic on an automatic basis, the total number of exchanges amounting to approximately 1 200.

The conversion of the local exchanges has made rapid progress. On January 1, 1938, 217 exchanges had been converted to automatic operation. Since the majority of the larger exchanges is included in this figure, the percentage of subscribers connected to automatic telephone exchanges amounted to 53.5% of the total number of 187 380. Adding to this figure the 100 000 subscribers of the cities of Amsterdam, Rotterdam and The Hague, all of whom are being served by machine switching equipment, the total number of subscribers now able to handle their calls automatically is 70% of the total number of lines connected in Holland. At the same time, the exchange networks have been grouped and cable plant provided to correspond with the division of the country into twenty rural zones or districts, constituting the basis on which the long distance traffic will be handled. Some particulars of the planning of this division, as well as a description of the Rotary type automatic telephone equipment in so far as operation within the Haarlem rural zone is concerned, have been given previously.<sup>1</sup>

<sup>1</sup> "The 7-D Automatic Telephone System in the Haarlem Rural Area," by F. O. Bloembergen, E.I., *Electrical Communication*, October, 1933.

The purpose of the present article is to describe the manner in which the installation of Rotary automatic telephone equipment in the city and rural areas of Haarlem has been extended with a view to permitting the establishment of calls on an automatic basis to and from other zones.

## Some Interesting Data

The Haarlem zone comprises the following number of exchanges and equipped lines :

	Exchanges	Lines
City area .. .. .	4	20 000
Rural area .. .. .	20	8 400
Total .. .. .	24	28 400

All these exchanges are now arranged for automatic intercommunication, both mutually and with exchanges in other zones throughout the country.

Inauguration of the service from the Amsterdam zone to that of Haarlem took place on February 28, 1938, 30 toll lines being available. The service from the whole of the Haarlem zone towards the Amsterdam zone, where some 60 000 subscribers are connected, was successfully opened to subscribers on July 1, 1937, over 24 toll lines. Since inauguration, it has been necessary to increase the number of these lines to 30, due to stimulation of traffic through the provision of automatic facilities.

## Open Numbering

In order to establish calls within a local exchange area, the wanted subscriber's number, which may consist of from three to six digits, depending on the size of the area, is dialled as usual. For a call to a subscriber connected to a distant exchange area, either in the local zone or in a distant zone, the subscriber's number

must be preceded by a prefix by means of which the wanted exchange area is identified. As many prefixes as exchange areas are obviously required.

The prefix always commences with "K"

of prefixes is equal to the number of zones.<sup>2</sup>

For the time being, the prefixes in use in the Netherlands comprise three figures and the "K." The first following the "K" determines the zone required ("centre de distribution").

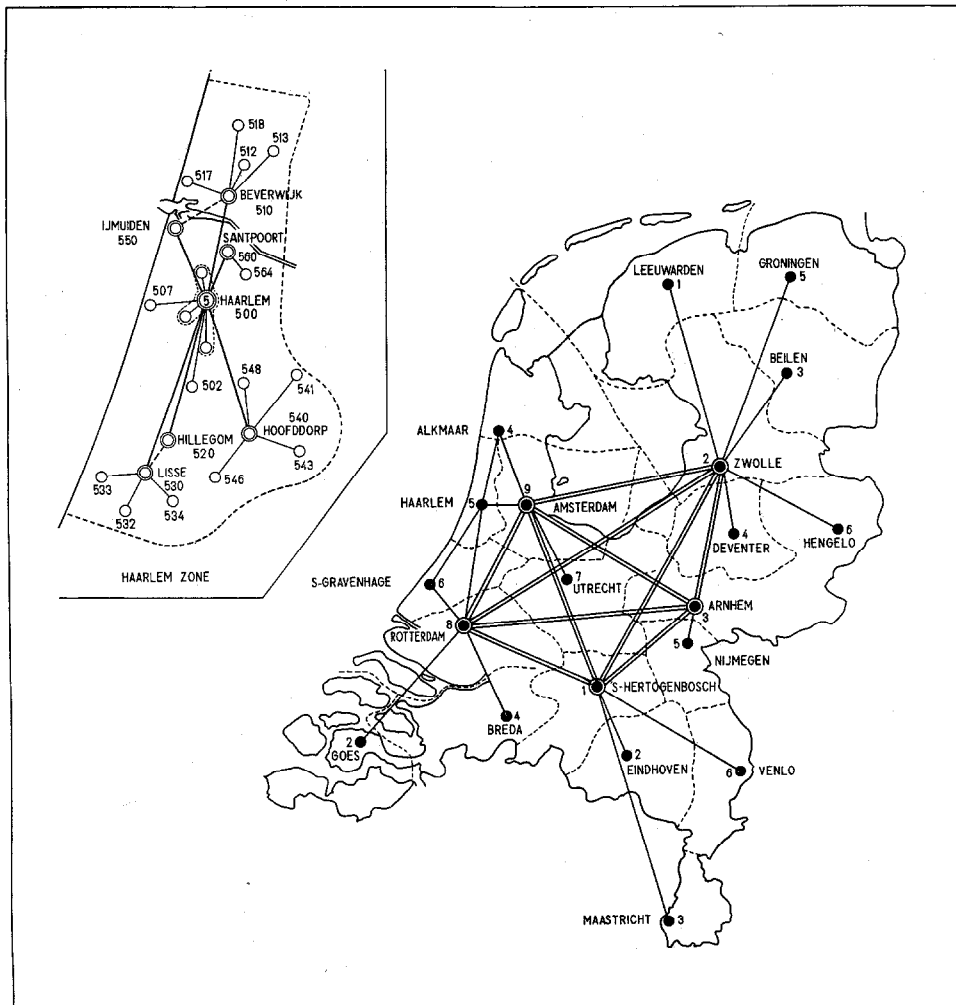

Fig. 1—Fundamental Toll Plan—Netherlands.

("K" = "0" on the dial). The number "0," therefore, is never used as a first digit in the local numbering scheme of an exchange area.

The scheme of numbering herein described is known as the "open numbering system" in contrast with the "closed" or "concealed" numbering system whereby all subscribers within any zone can call one another by dialling only the subscriber's number without a prefix. In the latter scheme, a prefix is used only when dialling into distant zones, and the number

The second relates to the sector in that zone or district; and finally, the third indicates the end or minor exchange. The three are referred to as "A," "B" and "C," respectively.

With this system of decimal numbering, the maximum number of exchanges is theoretically 1 000; but, since the combinations K-01 to K-09 and K-00 are reserved for special services, it follows that only 900 exchanges can be

<sup>2</sup> "The 7-D Rural Automatic Telephone System," by W. Hatton and J. Kruithof, *Electrical Communication*, April, 1935, pp. 317-8.



reached. Moreover, the subdivision is also on a decimal basis, resulting in 9 zones or districts, each of which contains 10 sectors individually offering the possibility of connecting 10 end or minor exchanges.

Automatic connection with eight other zones is thus possible. An example of the present numbering is :

Amsterdam zone .. ..	K-900 to K-999
Rotterdam zone .. ..	K-800 to K-899
Haarlem zone .. ..	K-500 to K-599

Fig. 1 shows the country divided into twenty zones. The first digit of the prefix is shown beside the name of the zone centre.

It will be seen that, at present, the same first figure is used for more than one district. For example, the figure 6 is used for Venlo, 's-Gravenhage and Hengelo but, of these three, only 's-Gravenhage is accessible to Haarlem

's-Hertogenbosch .. ..	K-1
Zwolle .. ..	K-2
Arnhem .. ..	K-3
Alkmaar .. ..	K-4
Haarlem .. ..	K-5
's-Gravenhage .. ..	K-6
Utrecht .. ..	K-7
Rotterdam .. ..	K-8
Amsterdam .. ..	K-9

Since the country is divided into twenty zones, connection with the remaining eleven can be made only through the intervention of an operator. For this purpose, five manual toll exchanges are planned: Amsterdam, Rotterdam, Zwolle, Arnhem and 's-Hertogenbosch, respectively. Each of these five toll exchanges can be considered as the nodal point of a group of zones for the purpose of handling operator-controlled toll traffic; they, therefore, are called "group centres." Fig. 1 illustrates the inter-connection of these manual toll exchanges.

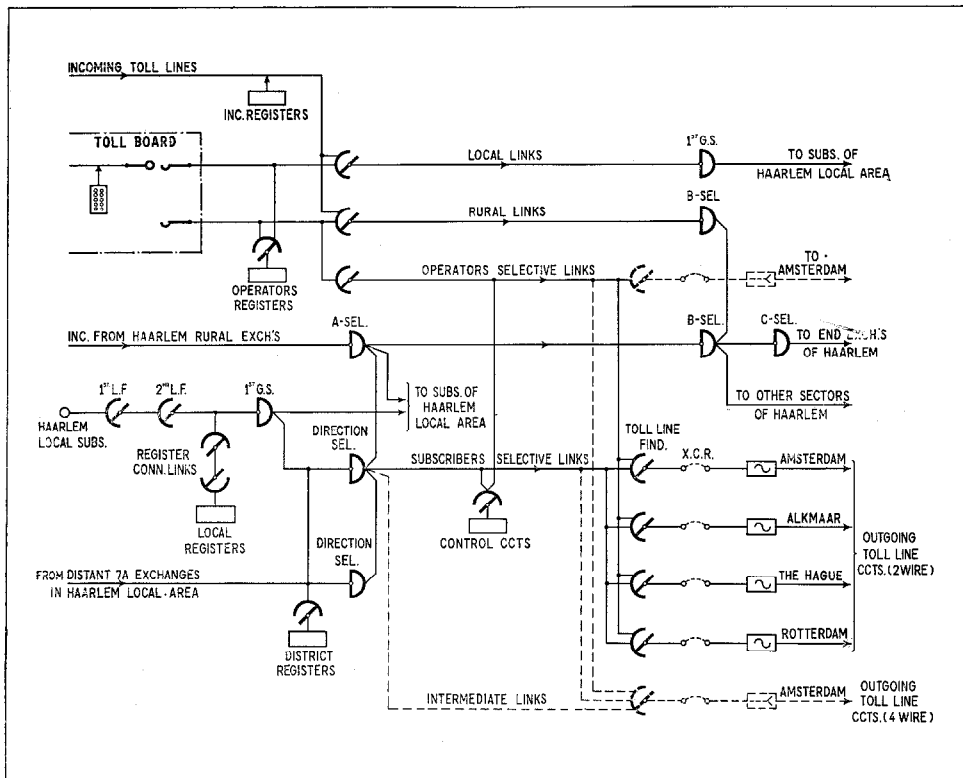

Fig. 2—Function Diagram of Haarlem Zone Centre.

subscribers on an automatic basis as may be seen from the following list of zones automatically accessible from Haarlem :

The manual toll service is not as yet completely concentrated in the five group centres, operators being employed in zone

centres such as Haarlem. The Haarlem operators have available the same facilities as those at the group centres, and have automatic access to the subscribers of all zones in the country, in so far as they have been automatised, and regular manual access to all manual networks.

The numbering scheme outlined above was adopted some years ago as a result of the consideration that 85% of the total toll traffic was directed to the local zone and the eight neighbouring or most important zones, so that merely 15% would be handled through operators if automatic access were given only to nine of the twenty zones.<sup>3</sup> Hence it was felt that the extra expense and complication of giving 100% automatic service would not be justified.

Subsequently as a result of the experience gained with the first toll lines converted to automatic long distance operation, the Administration has become convinced of the advantage of giving completely automatic service throughout the country. As a consequence, the exchange prefixes will shortly be changed to comprise four digits instead of three, besides the "K," and each zone will be identified by the two initial figures thereof. The first will indicate the group centre according to Fig. 1 and the second, the zone ("centre de distribution").

The introduction of four-digit prefixes will not only allow each subscriber to reach any other subscriber in the country automatically; but also, by a more flexible routing of calls and a more extensive application of alternative routing, it will permit a better utilisation of the cable plant. This, added to the saving effected in operating expense, more than outweighs the additional automatic equipment required.

### **National Dialling**

From an economic point of view, the Netherlands Telephone Network is in a favourable position for the introduction of national dialling, the principal reason being density of population of the territory served.<sup>4</sup>

<sup>3</sup> "Die Automatisierung des niederländischen Fernsprechnetzes," by J. H. Warning, *Fortsschritte der Fernsprech-Technik*, January, 1936.

<sup>4</sup> "Automatic Telephony in Country Districts of Great Britain," by E. P. G. Wright, *Electrical Communication*, July, 1937.

A fundamental requirement for the introduction of national dialling is the provision of ample toll line circuits so that no-delay service can be given. This type of service is especially advantageous when the traffic density is high since the efficiency of a traffic path in the case of no-delay service very considerably increases with the size of the group in which it is used. The efficiency becomes comparable with that obtained on lines worked on a delay basis only when the size of the group is relatively large. It will be evident, therefore, that the conditions for the introduction of no-delay service with high efficiency are particularly favourable in densely populated areas.

Inasmuch as distances are relatively inconsiderable in the Netherlands, one of the objections sometimes raised against national dialling, namely, giving subscribers the control of valuable circuits and cable equipment, assumes comparatively little importance.

One considerable advantage of the automatic handling of toll traffic is that a twenty-four hour service per day, for any kind of connection throughout the country, can be given to every subscriber. For subscribers of the smaller exchanges, to whom formerly even local service was given during only a part of the day, this is an important consideration. However, local automatic service, unless provision is also made for the possibility of calling outside the local area, has very little significance, particularly in the case of the smaller offices where the greater part of the traffic is non-local. With automatic long distance dialling, the subscriber is no longer dependent solely on a small local exchange, but has access to the complete network of the country.

That the public appreciates these advantages is indicated by the fact that automatised of the rural networks has caused a considerable increase in the number of subscribers. Toll traffic also has increased beyond the estimated figures.

National dialling also increases the efficiency of the cable plant, inasmuch as the time required to establish an automatic toll call is less than when the connection is built up by an operator.

Another factor meriting consideration is the possibility of extensive applications of tandem trunking and alternative routing. The efficiency

of the cable plant is thus increased due to the fact that small separate groups of lines may be combined in larger groups with improved traffic handling efficiency per line.

National dialling provides high grade, general uniformity of service. Automatic toll calls are established over the entire country in exactly the same way. A small percentage of calls, which for some reason or another must be handled manually, may ultimately be concentrated at a small number of toll boards (five in the Netherlands) where uniform methods are also easily applicable.

### **Metering**

With national dialling, the tariff must be metered automatically for each call. Charges to the calling subscriber are made in accordance with a unit tariff and the duration of conversation.

In the Netherlands, the cost of long distance calls is counted on subscribers' message registers on the basis that the tariff per unit of time (three minutes), for all kinds of calls, is a multiple of the local calling fee, as may be seen from the following tariff table :

Local call .. .. .	2 cents
Toll call for distances :	
0-10 km. .. .. .	4 "
10-15 " .. .. .	10 "
15-25 " .. .. .	20 "
25-35 " .. .. .	30 "
above 35 km. .. .. .	40 "

The fee for local calls is independent of their duration. Toll calls are metered for every three minute period ; and, in the Rotary system, metering takes place at the beginning of each three minute conversation period, except at the beginning of the first period, when it is delayed by approximately ten seconds in order to provide for subscribers verifying the correctness of the connection and for releasing without metering in the case of a wrong connection.

### **Routing of Toll Calls in the Haarlem Zone**

The junction diagram of the Haarlem rural main exchange or zone centre (Fig. 2) indicates the manner in which the various kinds of call are completed through Haarlem. For the purpose of simplification, a part of the local train of switches has been omitted, namely, the 2nd and 3rd group selectors and final switches

for local traffic in the Haarlem local exchange ; also, the switches handling traffic from the rural area to the Haarlem city subscribers.

Connections originating in the Haarlem rural zone enter the Haarlem rural main exchange on so-called "A" selectors. When directed to sectors or end exchanges of the same zone, they are switched via "B" selectors to the required sector, and thence over "C" selectors to the end exchange. Connections between one end exchange and another of the same sector do not pass through the Haarlem exchange.

Connections directed to four of the most important nearby zones are established over direct toll lines or tie lines from the Haarlem rural main exchange to that of the required zone, 50-cycle signalling circuits being employed.

To the arcs of the backward hunting finders, associated with the outgoing toll lines to the four directions mentioned, are multiplied so-called "selective link circuits" for operators and subscribers. These, in conjunction with a temporarily attached control, cause the particular group of toll line finders to which the call is directed to hunt for the selective link handling the call.

The operators' selective links are associated with backward hunting finders in the arcs of which the toll operators' jacks are connected. The subscribers' selective links are multiplied in the arcs of three groups of selectors. From the junction diagram it will be seen that two of these groups of selectors, called "direction selectors," can be reached over a level of the 1st group selectors of the Haarlem City area, one group being provided for the Haarlem main exchange (which is installed in the same building) and the other group for other exchanges in the local area. The third group of selectors is the group of "A" selectors used for traffic originating in the exchanges of the Haarlem rural zone.

### **Calls from Haarlem City Subscribers**

When a subscriber in the Haarlem local area dials the prefix of a distant area, the call is directed by the local register to a direction selector. The direction selector then seizes a district register, which then takes charge of the call.

The district register causes the direction selector to choose a free selective link circuit and control circuit, whereupon it sends the first digit following "K" (the "A" figure) into the control circuit. The latter circuit then enables the selective link circuit, for the purpose of hunting, to mark one of the four groups of toll line finders.

When a free toll line finder has been connected, the control circuit releases, and the district register proceeds to send the next two figures of the prefix ("B" and "C") via the tie line into the distant district.

The district register performs still another function, namely, it indicates the number of times the subscriber message register must operate per unit of conversation time. The tariff being dependent on the prefix, the district register by means of a translator sends a signal to the time and zone metering equipment associated with the direction selector in order to set it for a predetermined number of metering operations for each three minutes' interval.

When the selection of the prefix has been completed, the district register disconnects itself. A second dialling tone is transmitted from the distant exchange, and the subscriber may dial the wanted party number, which is

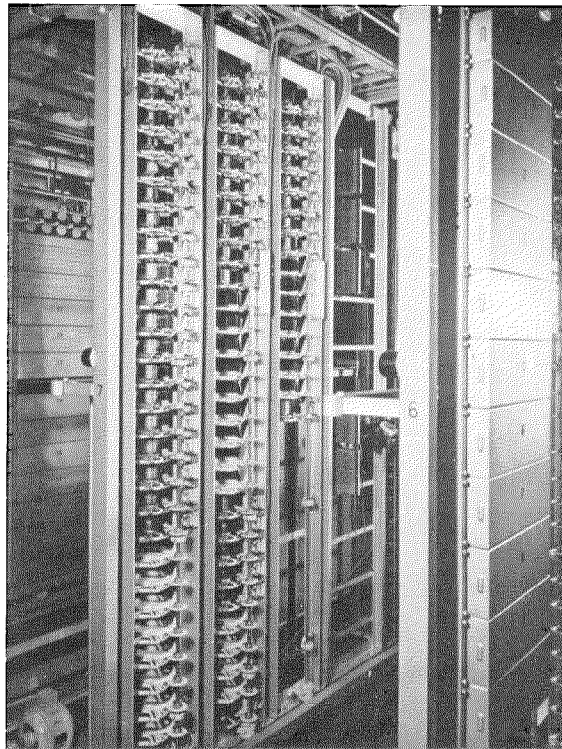

Fig. 4—Finder Bays and Cross Connecting Rack.

conveyed directly via the toll line in the form of 50 cycle impulses to the distant area.

When the called subscriber answers a signal is passed back from the distant exchange to the direction selector, thereby starting the time and zone metering apparatus.

**Calls from Haarlem Rural Subscribers**

Traffic from subscribers in the Haarlem rural district (7-D Rotary equipment) to nearby districts connected by direct tie lines to Haarlem is handled in a manner similar to that described for calls from Haarlem city subscribers, but

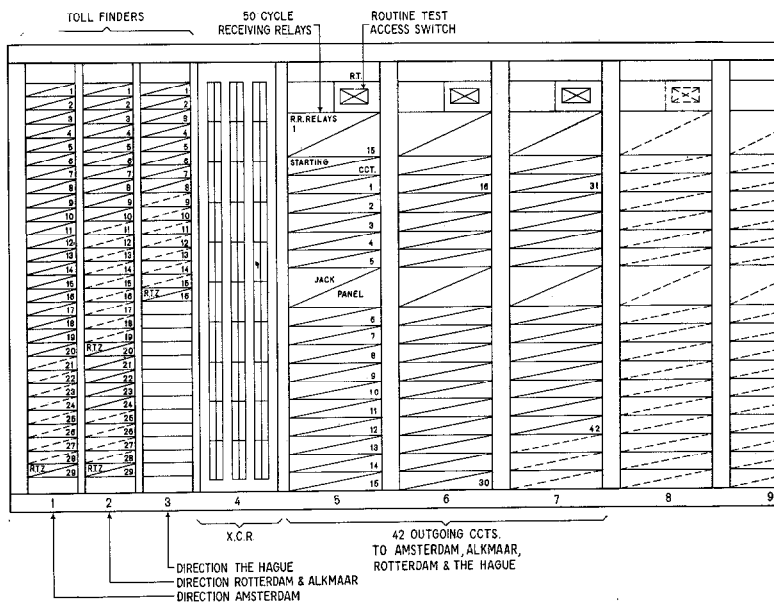

Fig. 3—Equipment Layout of Switchboard with Outgoing Toll Line Circuits (Front of Rack).

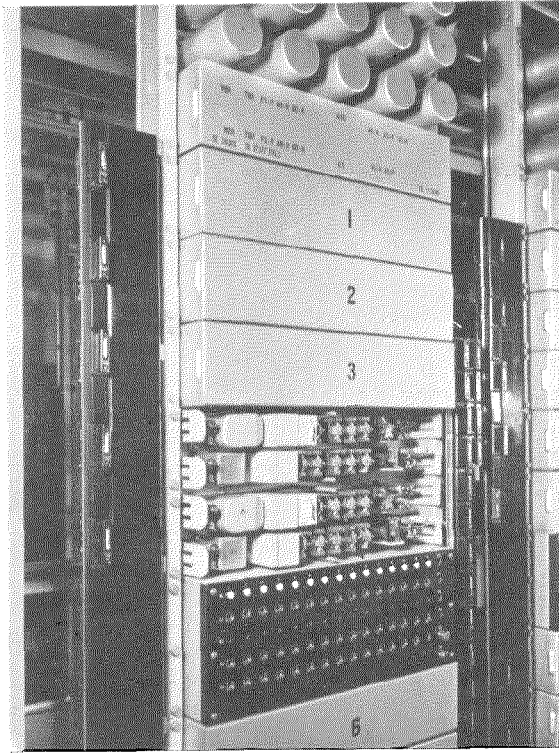

Fig. 5—Part of Bay Mounting 50-Cycle Outgoing Toll Line Relay Group.

for this class of call the rural centre register performs the function of controlling the prefix selections. The registers in the rural centre exchange also control the time and zone metering indication. The time and zone metering equipment is placed in the rural exchange, and is started under the control of a back impulse received at the moment the called subscriber answers.

#### ***Calls from Haarlem Toll Operator***

For connections established by the toll operator, a keyset register is attached to the jack as soon as the operator has plugged in. The operator transmits the prefix of the wanted exchange as well as the sub-

scriber's number. Depending on the prefix sent, the toll register causes the jack to be picked up either by a rural link (for a subscriber of the Haarlem rural area) or by one of the operators' selective links (for a call to a distant district). In each case, the keyset register controls the completion of the call.

#### ***Tandem Service via Amsterdam Group Centre***

The direction selectors are of the rotary single motion type, and their arcs are divided into three groups of terminals or "levels." One level is required for calls commencing with K-4, K-6, K-8 and K-9, which correspond to zones connected by means of tie lines to Haarlem. A second level is used for calls commencing with K-1, K-2, K-3 and K-7, e.g., for connections to zones not directly connected to Haarlem by tie lines, but which are tandemed through the Amsterdam group centre. The third level is used for the traffic remaining inside the Haarlem zone.

The "A" selectors, for calls from the rural district, have a similar division of their arcs, but an additional level is used for calls to subscriber lines of the Haarlem local area.

The level of the district selectors and "A" selectors corresponding to prefixes K-1, K-2, K-3 and K-7, referred to above, leads to inter-

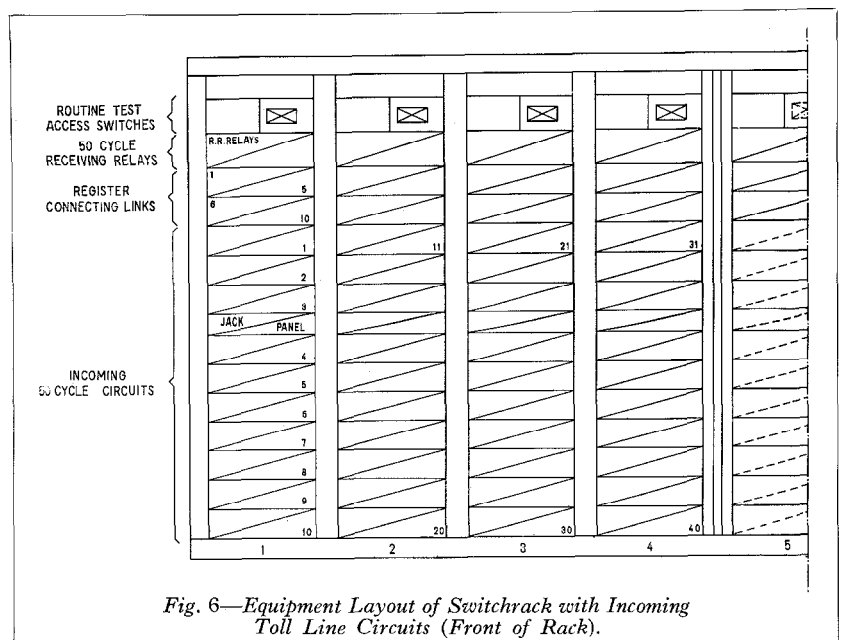

Fig. 6—Equipment Layout of Switchrack with Incoming Toll Line Circuits (Front of Rack).

mediate links, which are connected in the arcs of a group of toll line finders associated with four-wire lines to Amsterdam. The equipment for these four-wire circuits is indicated in dotted lines on the junction diagram (Fig. 2).

On calls commencing with K-1, K-2, K-3 or K-7, the district or rural register routes the connection via the intermediate link to the four-wire lines to Amsterdam. The intermediate link does not contain selecting equipment, and the "A" figure sent by the register is immediately passed on to Amsterdam to set the "A" selector, at the incoming end of the line, to the level corresponding to the wanted zone. The lines from Amsterdam to the zone involved are also four-wire and, consequently, for this tandem operation, two four-wire lines are placed in series. Voice frequency signalling is used on the four-wire lines.

#### ***Overflow of Traffic to Tie Line Directions via Amsterdam***

Means have been provided whereby, if all tie lines to a given direction are occupied, the call can be routed alternatively via Amsterdam. For this purpose, the selective link circuits are also multipled over the finder arcs of the backward hunting finders associated with the four-wire toll line circuits to Amsterdam. Assuming that all lines in a given tie line direction are occupied, the control circuit of the selective link circuit receives an indication to this effect and then causes the four-wire toll line finders to hunt for the selective link circuit. It will be clear, however, that under these conditions care must be taken initially to send the "A" selection to Amsterdam in order to set the "A" selector to the level corresponding to the wanted zone. As the "A" selection is received from the district register at the control circuit, the latter repeats it to Amsterdam before releasing and before permitting the district register to proceed with the "B" and "C" figures of the prefix. This is evidently possible by using a register which can be arranged to send its selections independent of the speed of dialling.

#### ***Accessibility of Toll Lines to Operators***

At present, the toll operators of the Haarlem toll board are charged with the completion of

those calls which cannot be established automatically prior to the complete automatization of the country and the introduction of the four-digit prefix system. For the nearest districts, the operators have access to the same groups of tie lines as are used for subscriber traffic. When the four-wire circuits to Amsterdam are in service, this route also will be at their disposal. In addition, the operators will have access to another group of four-wire circuits to Amsterdam for connections to all zones which cannot be reached directly by three-digit prefixes and which terminate at Amsterdam on so-called "S" selectors. On the Amsterdam "S" selectors, a selection will be made to direct the call to one of the other four group centres shown in Fig. 1.

The lines connected in the arcs of the "S" selectors are also four-wire lines and enter on "A" selectors at the other group centre, whence access is obtained to the required zone.

In order to reach the zones accessible via "S" selectors, the operators send a four-digit prefix, the first digit of which is the "S"

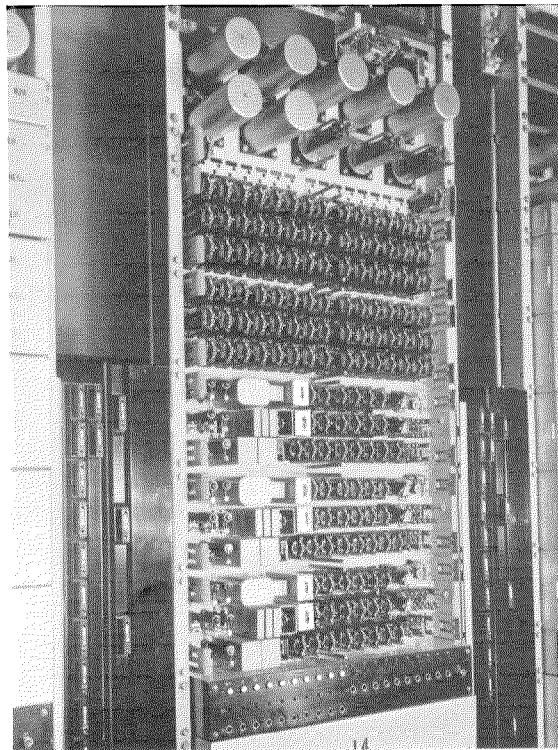

Fig. 7—Incoming Toll Line Circuits and Register Links.

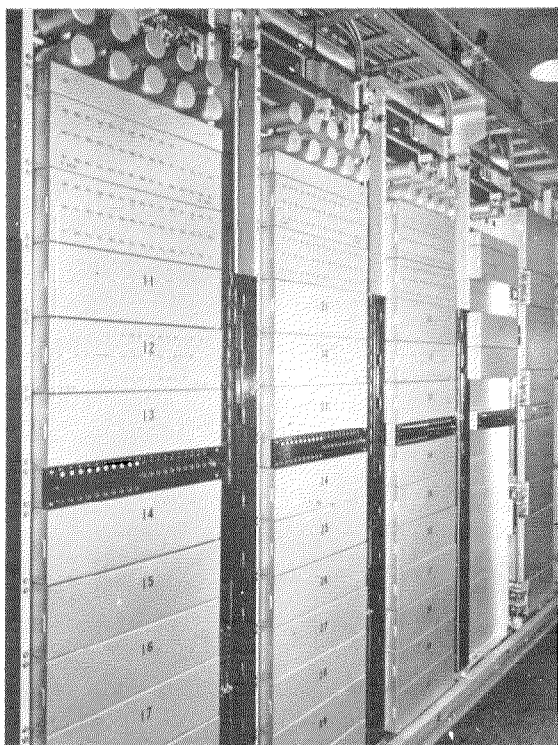

Fig. 8—Switchrack with Incoming Toll Line Equipment.

indicating the group centre. The three other figures have the same significance as the "A," "B" and "C" figures sent by subscribers.

#### **Incoming Calls from Distant Zones**

Connections from other districts entering on incoming toll lines are multiplied in the arcs of two groups of backward hunting finders, which are associated with link circuits for traffic to the local network and to the rural Haarlem network, respectively. The circuits are designed to work from distant exchanges of different types, rotary as well as step by step. The toll lines may be operated either by 50-cycle or voice frequency currents, and for the purpose of completing the selection in the Haarlem local and rural zones they may temporarily attach a register. The first impulse of the first train of dialling impulses arriving on the toll line causes instantaneous connection of the register, so that this first impulse is received at the register. This is accomplished by register links comprising relays only.

#### **Equipment**

The local equipment of the Haarlem main exchange, which consists of 7-A Rotary equipment, has been extended to the maximum capacity of 12 000 subscriber lines permissible by the available floor-space. The automatic toll equipment is installed in a separate switchroom.

Fig. 3 illustrates the equipment layout of the outgoing 50-cycle circuits. Toll line finders and the outgoing toll line relay groups are mounted on the same rack. An associated cross connecting rack is provided for jumpering the relay circuits to the finders for the various directions, as dictated by traffic requirements.

Fig. 4 shows the finder bays and the cross connecting rack, which may be seen at the left-hand side of Fig. 3. Fig. 5 shows part of a bay mounting 50-cycle outgoing toll line relay groups.

The mounting plates of Fig. 5, from which the covers have been partially removed, each mount a complete circuit with the exception of the polarised relays used in the 50-cycle receiving unit<sup>5</sup> which may be seen at the top of the bay.

At the left-hand side of each bay may be seen a strip of fuses. These are the 50-cycle fuses which are provided individually for each circuit and which protect the individual 50-cycle supply transformer of the circuit. The supply transformers are concealed behind the 50-cycle fuse strips, and are connected by short wires to the 50-cycle sending relays mounted under the square protecting covers immediately adjacent to the transformers. The potential on the primary side of the transformer, to which the fuse is connected, is 12 volts and is stepped up by the transformer to 60 volts or 120 volts, as required by the type of receiving equipment at the distant end of the line. With the equipment arranged as described, the 50-cycle high potential is present on a small part of the equipment only.

The direct current fuses for all the circuits are mounted on the right-hand side of the bay.

The mounting plate immediately underneath the polarised relays of the 50-cycle receiving

<sup>5</sup> For the 50-cycle circuits, see: "A Field Trial of 50-Cycle Signaling on Toll Lines," by W. Hatton, *Electrical Communication*, October, 1936.

units contains the apparatus for the common alarm circuit; also the starting circuits for the toll line finders.

As shown in the illustration, the row of 15 circuits is interrupted between the fifth and sixth circuits by a jack panel. This jack panel, for each circuit, contains a busy lamp controlled by a common key, a listening jack, a busy jack, a routine test jack, and a test jack to permit adjustment of the polarised relay. By means of the last mentioned jacks, it is also possible to check the current received in the polarised relays from the distant end.

The 50-cycle incoming circuits are mounted in a similar way on a separate switch-rack. The equipment layout of this rack is illustrated in Fig. 6; Figs. 7 and 8 show further details.

The capacity of a bay is 10 incoming circuits. The bay also contains the register link circuits and a jack panel.

Fig. 7, at the top of the bay, shows the polarised relays forming part of the 50-cycle receiving units. The 6 rows of relays below them form part of the register link circuits. The jack panel, seen in Fig. 8, contains a busy jack and a busy lamp for each circuit.



*Illustrating method of controlling the perpendicularity of a quartz crystal by means of polarised light, resulting in the formation of "airy" spirals—Les Laboratoires, Le Matériel Téléphonique, Paris.*



# The Application of Styrene to H.T. Cable Systems

By T. R. SCOTT, D.F.C., B.Sc., M.I.E.E., and J. K. WEBB, M.Sc., A.M.I.E.E.,

*Standard Telephones and Cables, Limited, London, England*

## PART III

*In Parts I and II of this article an account was given of the early experimental work carried out in applying the technique of styrenation to joints and terminations for high tension cables. Some discussion was also included of the problem of migration of compound in cables, which led to the adoption of stop-joints and barriers. In the present instalment, a description is given of how the effort to simplify the construction of styrene joints and terminations resulted in discoveries which considerably extend the scope of styrenation. Inhibition (as defined hereinafter), acceleration, the use of plasticisers, etc., have been studied in considerable detail with important results which are dealt with herein. Reduction of time of polymerisation in the field has been achieved. New fields of development and application have become evident, in comparison with which the original applications recede into positions of relatively minor importance.*

**I**N Part I of this article, the commercial difficulties arising from the tendency of monomeric styrene to polymerise at room temperature, in storage, and during transport were considered. This question has now been studied in detail, and satisfactory methods have been evolved to overcome the inconvenience and loss associated with such premature polymerisation.

The problem includes the control, in general, of the time taken to effect polymerisation, which early experience showed was apt to be irregular in its operation, and consequently introduced considerable uncertainty in the fabrication of styrene plugs and joints. Furthermore, monomeric styrene during storage or transport frequently polymerised unexpectedly even though stabilising material had been added to inhibit polymerisation.

Although it was known that the rate of polymerisation was a critical function of temperature within the immediate range of 120°C., the effect of the presence in solution of certain materials in very small quantities was not at first appreciated. Such materials may be added intentionally, in which case they may be classified as accelerators, retarders, or inhibitors. Otherwise, they may be added inadvertently or accidentally, in which case the general effect is usually one of retardation. Impurities find their way into the styrene in the course of joint

construction chiefly through contamination from the jointer's hands. Besides slowing up the rate of polymerisation, such impurities raise the power factor of the monomeric styrene quite considerably, although on polymerisation the resultant increase may be negligible. It was, in general, soon found that there is an intimate relation between the rise in power-factor due to the addition of impurities and the rate of polymerisation.

This led to a closer examination, by Dr. S. G. Foord, of the Chemical Laboratory of Standard Telephones and Cables, Ltd., of the factors affecting the mechanism of polymerisation. It was found that any given sample of monomeric styrene has an induction period during which no polymerisation, as indicated by change of viscosity, takes place. After this period, the styrene suddenly commences to polymerise, the rate increasing to a maximum; it then continues steadily at a rate depending on the temperature. It is the function of *inhibitors* to control the *duration* of the induction period only, while *retarders* and *accelerators* affect the *rate* of polymerisation once it has started. While some substances clearly fall into one or other of these categories, there are also others which combine both functions.

It has long been known that quinone added in considerable quantity would substantially prevent polymerisation of monomeric styrene, but the

work of Dr. Foord has shown that small quantities increase the induction period appreciably and, therefore, enable accurate forecasts to be made of the period of time during which the material may be stored or heated without increase of viscosity. Fig. 1 illustrates graphically the effect of adding a small quantity of quinone to pure monomeric styrene. The addition of large quantities of an inhibitor, e.g., quinone, achieves such complete inhibition that distillation or some similar process must be applied to free the styrene for polymerisation. Distillation is a very inconvenient process to apply in the field or even in a cable factory. The discovery of the effect of the addition of small quantities of inhibitor, therefore, had revolutionised styrenation technique.

It appears to have been general practice in the past to study the effects of inhibitors by observing the total time taken to effect complete polymerisation. It has apparently been assumed that such inhibitors slowed down the rate of polymerisation, i.e., the rate of increase of viscosity. Fig. 1 shows by the slope of the log-viscosity/time curve that this is not the case for the small quantity of quinone added in this instance. It is a case of inhibition without retardation.

Several of the inhibitory materials examined were found to be only very slightly soluble in the monomeric styrene and, since the completion of the induction period coincides with the solute becoming exhausted through chemical transformation, it follows that, if excess of the inhibitor be added, the induction period can be lengthened by any desired amount. As fast as the solute is used up, more dissolves and preserves the state of maximum concentration. Ordinary convection currents, aided by diffusion, appear to be sufficient to give a uniform dispersion.

A typical example of an inhibitor of this class is metol, which is only very slightly soluble (i.e., about .001%). This promotes an induction period of over 2 months at 30°C., decreasing to 10 minutes at 120°C.

Destabilisation may be effected by heating for the time corresponding to the induction period. If excess metol (or a similar inhibitor) is present, it must first be removed by filtration.

The addition of any stabiliser has the effect of raising the power factor of the monomeric

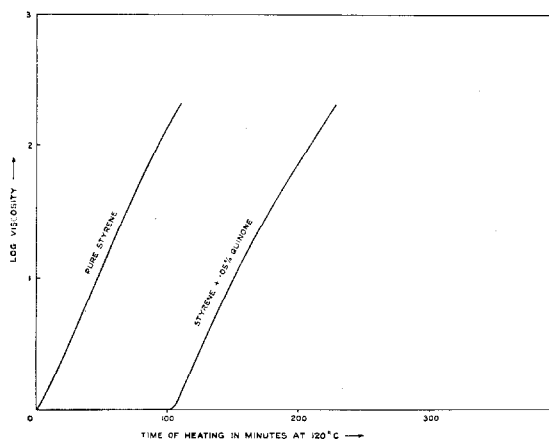

Fig. 1—Showing the effect on the polymerisation characteristics of styrene by the addition of a small quantity of quinone. It will be noted that this gives rise to a distinct "induction period" during which no polymerisation takes place, following which the rate of polymerisation is about the same as that for pure styrene.

styrene, but under properly controlled conditions this effect is usually negligible when the polymeric state is reached.

The discovery of the induction period is also likely to have far reaching effects in connection with styrenation processes, which depend on the washing out of oil or compound from cables by flushing through with styrene. At one stage in the development, owing to the irregular behaviour of styrene, it was considered preferable to use benzene or some other oil solvent for such purposes. The objection to styrene was the liability of premature polymerisation cutting off the flushing process before all the oil had been removed. Inhibited styrene can, however, be used safely for this purpose. Benzene is still used for certain special applications in which its higher vapour pressure is of advantage. When stabilised styrene is used as a solvent, the process results in the collection of considerable quantities of an oil/styrene mixture. A simple method of recovering the styrene from such a mixture, however, was devised by Mr. A. J. Warner of the Chemical Laboratory of Standard Telephones and Cables, Ltd., so that no wastage of styrene occurs.

Plasticisers are frequently added to modify the mechanical properties of the polymer, but it has been determined that their presence has little influence on the action of the stabiliser.

In general, however, they have a certain retarding influence on the rate of polymerisation. The same may be said of other substances which, while being soluble in monomeric styrene, separate out on polymerisation. A typical example of this class of substance is the mineral oil used for impregnating cables. Adulteration with oil will retard polymerisation in the case of joint construction. This is probably purely a question of dilution.

Monomeric styrene, properly stabilised, may thus be conveniently stored and transported without risk of deterioration, while the time necessary for polymerisation at 120°C. is but little affected. Only negligible change occurs in the electrical characteristics of the polymer.

While this study gave a clearer conception

of the factors governing the process of polymerisation, and provided a convenient means of preserving styrene in the monomeric form indefinitely, it still offered no solution to the anomalies introduced by the addition of impurities. Although accelerators were found which increase the rate of polymerisation, they in general only do so at the expense of a relatively large increase of power factor; hence, their scope is limited. Although a case may be made out for the use of limited quantities of an accelerator in many instances, it is nevertheless bad technique to use an accelerator to neutralise the effect of an inhibitor. This is a case of dual contamination of the styrene.

Technically also it is almost axiomatic that "slow" polymerisation produces the type of

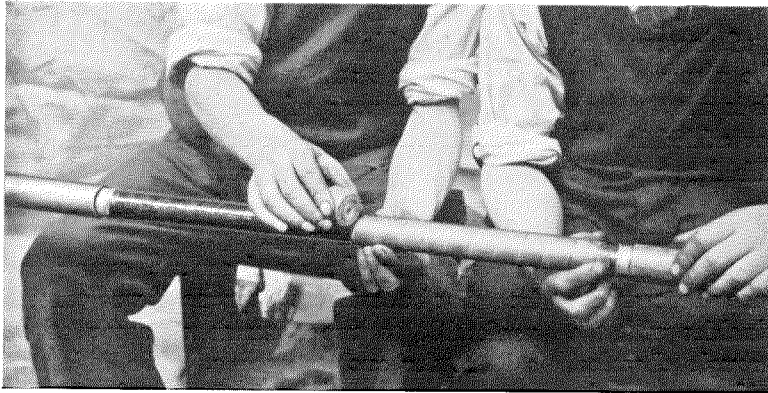
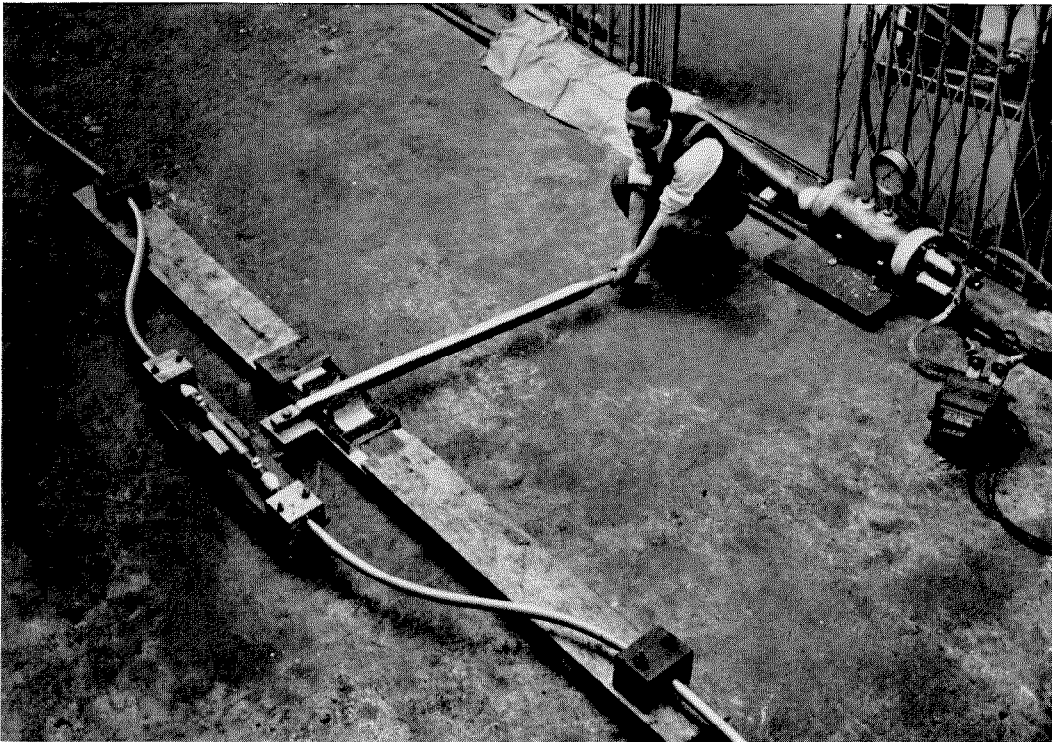

*Fig. 2—Lapping on the paper tape.*

*Fig. 3—Coating the layer just applied with a film of monomeric styrene before winding on the next layer. This first serves as a lubricant, until it more fully interacts with the polystyrene in the paper, which it then causes to swell, and so forms a thick plastic mass with a good barrier action. The monomer is converted to polymer in course of time.*



*Figs. 2 and 3—Two stages in the fabrication of a styrene joint by the "cold process" using pre-polymerised styrenated paper.*



*Fig. 4—Bending Test on a Styrene Joint. Joints in practice have to withstand the forces set up when the cable expands out of a duct. The test illustrated for the case of a 33-kV joint simulates such conditions.*

polymer which is most desirable for high tension cable work. The low temperature ("slow") polymers have, in addition, a higher softening point, which is of considerable importance in cable work. Generally speaking, therefore, the use of accelerators is only justified on economic grounds.

Polymerisation which has to be effected completely "in situ" in the field has several drawbacks, even if all anomalies could be eliminated. There is the difficulty of providing suitable heating equipment, as well as the careful supervision required, very often intensified by awkward locations. The time taken up in effecting polymerisation on site must also be deprecated, while another unfavourable factor is the thermal contraction which must inevitably occur on cooling down from the polymerisation temperature. There is also a serious risk of oil adulteration in the early stages of polymerisation, frequently

necessitating the application of freezing mixtures or CO<sub>2</sub> snow to the cable. Furthermore, in the case of a cable joint, it is hardly possible to obtain a uniform temperature throughout, on account of the relatively high thermal conductivity of the copper conductor.

While satisfactory joints can be made despite these adverse influences, much thought was given to any possible simplification of the process.

One of the present authors<sup>1</sup> attempted for some time to produce a paper impregnated in monomeric styrene and polymerised in the factory. The idea was to use such pre-polymerised paper tapes in the fabrication of the joint and so reduce or, if possible, eliminate the heating period required in the field. Some formidable difficulties had to be overcome. Attempts to styrenate the paper by lacquering

<sup>1</sup> J. K. Webb. B.P. 454 923.

proved to be somewhat unsatisfactory on account of the incompleteness of impregnation. Neither was it found commercially practicable to impregnate with monomeric styrene and polymerise the paper in sheet form. While it was possible to impregnate and polymerise a roll of paper in a sealed container, the difficulty then arose of separating adjacent layers. This, of course, could be overcome by adding a relatively large proportion of plasticiser to the styrene, but it led to the rewound paper re-adhering when subjected to quite low temperatures.

A thorough investigation into the scope and range of available plasticisers was then undertaken by Mr. A. J. Warner, and the success of the final process evolved is largely due to the proper selection of the plasticiser incorporated in the styrene, both with regard to quality and quantity. Other factors of course also had to be examined and controlled.

As the result of this work there can now be produced, on a commercial scale, a paper which has been dried, impregnated with monomeric styrene (with a small addition of plasticiser) and polymerised in roll form, adjacent layers of the paper being afterwards separated by unwinding. The surface may be calendered and, on rewinding into roll form,

there is no tendency for adjacent layers to re-adhere, even when heated to 120°C. On account of complete penetration of the styrene into the paper fibres, this paper has remarkable electrical characteristics which will be fully discussed later, and which distinguish it completely from any so-called styrenated paper which is prepared by merely lacquering. Such lacquered paper has only about one-third of the breakdown value of paper prepared by the impregnation process, the latter having a B.D.V. of about 1 500 volts/mil (or 60kV/mm.), when the paper thickness is 5 mils (or .127 mm.).

In making a joint or termination, this pre-polymerised styrenated paper is wound on in the usual way, but each layer in turn may be given a coating of monomeric styrene as illustrated in Figs. 2 and 3. The immediate effect of this coating is to act as a lubricant, which enables the tapes to be tightened. After a few seconds, the polymer in the paper swells as it enters into solution with the film of monomer, and a thick plastic mass ensues. When the joint has been finally taped in this way, although it still contains a certain amount of monomer, the resultant build-up is sufficiently hard to act as a barrier. Furthermore, the electrical characteristics are excellent, so that it may be placed forthwith in service, when the process of polymerisation will continue at ordinary temperatures over a period, perhaps, of several months. This will, however, in no way detract from the electrical characteristics.

The space between the lead sleeve applied over the joint and the insulation can be filled with rubber, which is afterwards swollen by the addition of mono-styrene. A thick rubber-like mass is consequently formed, tightly sealing the channel and completing the barrier.

The so-called "cold process" just described and illustrated in Figs. 2 and 3 has thus succeeded both in very considerably simplifying

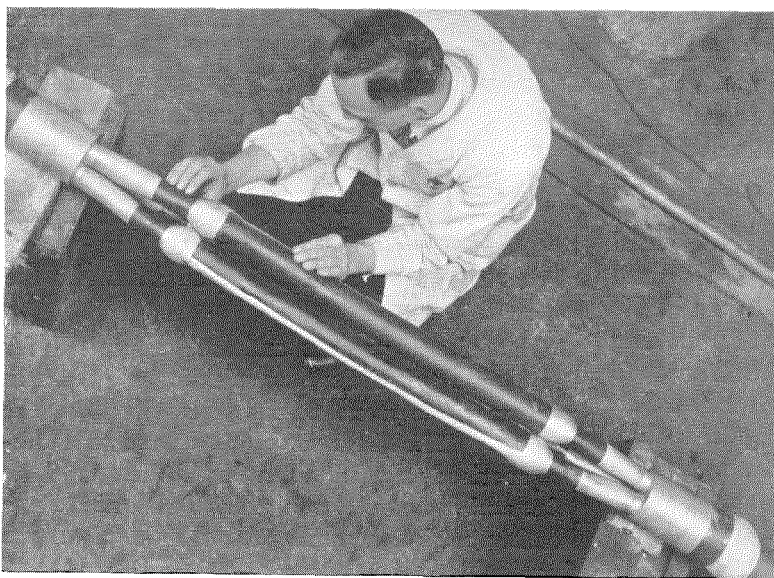

*Fig. 5—Trifurcating type of styrene barrier joint for 3-core screened cable. A similar construction allows the change-over from screened cable to single-core terminating tails to be conveniently effected.*

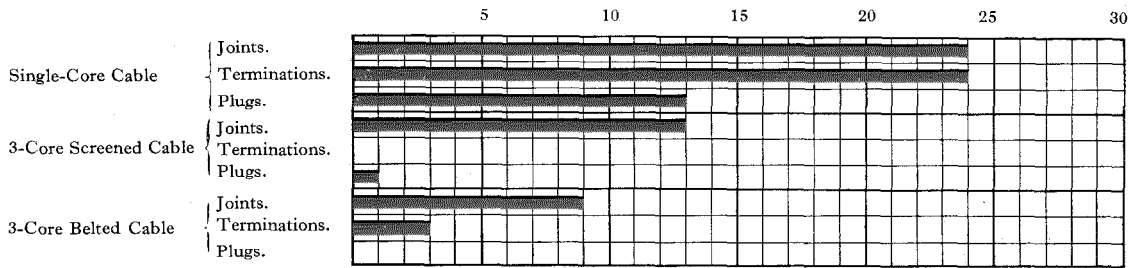

Fig. 6—Record of Styrene Joints, Terminations and Plugs installed to date, on cables of varying voltage up to 66kV.

the technique of joint construction and, also, of improving the electrical characteristics. The latter improvement is probably partly due to the elimination of the voids formed through thermal contraction when the joint had to be polymerised at 120°C., and also to the contraction attendant upon polymerisation, when this had to be carried out completely "in situ." In the cold process there is also less liability of contamination from the jointer's hands since there is less contact with the monomeric styrene.

In testing joints on a 33 kV cable system (i.e., 19 kV to neutral), voltages of 60, 70, 80, 90, 100, 110, 120 kV, etc., to earth are progressively applied for a period of one hour each. Joints recently constructed have successfully withstood this test, breakdown occurring in the cable. In making such tests, the Condenser Cone<sup>2</sup> is a useful adjunct for reinforcing the cable ends. Joints have also been subjected to bending tests to simulate the movement of cable from ducts, as illustrated in Fig. 4, and to life tests under severe conditions of current loading and excess voltage over prolonged periods with completely satisfactory results.

The "bending test" consists of first clamping the joint and arranging the associated cable as under service conditions, in which case the cable is bent away from the joint before it enters the ducts. The purpose of this bending is to accommodate the movement of the cable due to thermal expansion. In the present test such movements are greatly exaggerated by the mechanical means illustrated, and the process

taken through many cycles while the joint is simultaneously being pressure tested.

This new technique, employing pre-polymerised paper tapes, was soon extended to terminations. An easily constructed barrier type has thus been evolved, isolating the oil in the cable from that in the pothead. It was mentioned in Part II of this article.

In the case of 3-core screened type cables, a trifurcating joint of simple construction has been designed and constructed (Fig. 5). It should lead to great economies in barrier joints in cables of this type.

For the 3-core screened type of cable, this joint provides simultaneously a straight through or trifurcating joint and a barrier joint. The trifurcating aspect is probably of the greatest importance since it has hitherto been difficult to terminate simply 3-core screened cables, particularly when it is desired to introduce single-core tail cables for ease of installation at the termination. This joint renders the change-over from screened 3-core to S.L. or single-core cable a simple matter, involving small space requirements and at the same time introducing a barrier effect in a position where in general it is of maximum advantage. It is believed that this type of joint may remove some of the disabilities of the 3-core screened cable and permit distribution and transmission engineers to make greater use of the advantages and economies arising from the use of this type of cable.

Multicore belted type cables required the development of styrenated fillers made from textiles and other pre-polymerised materials. This has also been successfully undertaken.

The fundamental principle of the "cold process" may be described in a simple manner,

<sup>2</sup> "The Condenser Cone—A New Device in Connection with High Tension Cable Terminations and Joints," by J. K. Webb, *Electrical Communication*, October, 1933.  
"Condenser Cones for Cable Testing," by J. K. Webb, *Electrical Communication*, April, 1937.

as follows. Complete polymerisation of monomeric styrene to polymeric styrene as checked, for example, by the cessation of smell (which indicates elimination of the majority of the monomer) is a comparatively long process compared with the thickening of the monomer into a plastic solid which forms a barrier to hydraulic pressure. In the last-mentioned stage there exists a considerable proportion of unpolymerised monomeric styrene which serves to plasticise the polymer. It is reasonably certain that in most of the barrier joints and terminations so far constructed by the "hot process" (i.e., polymerisation effected in the field) heating was discontinued long before 100% polymerisation was attained. The joints polymerised in the field direct from monomer were, therefore, just as plastic, just as incompletely polymerised, as the joints made by the cold process herein described. The ageing characteristics of joints, still being investigated, show improvement of electrical characteristics over periods of weeks, regardless of whether the joints have been made by the hot or cold process. Some of these effects are undoubtedly due to the

continuation of the polymerisation process. It may be emphasised here that tests taken on joints or terminations immediately after fabrication give a relatively poor indication of the characteristics of the joint under service conditions when ageing is completed.

The same effect as that produced by heating monomeric styrene can be obtained by adding a relatively large volume of polymer to a relatively small volume of monomer; the latter dissolves or swells the former and yields a plastic mass. This action is the one used in the "cold process," for example, by the mixture of styrenated paper containing polymer with a small quantity of monomer as described in the joint construction given above. The action can be used in a number of ways to give a variety of results, and its discovery is of outstanding importance in this field of development. A short period of heat treatment may be desirable in some cases, particularly if the percentage of monomer is high; but, for all items of the joint and termination category, save only the plug, the prolonged heat treatment has been eliminated from commercial practice.

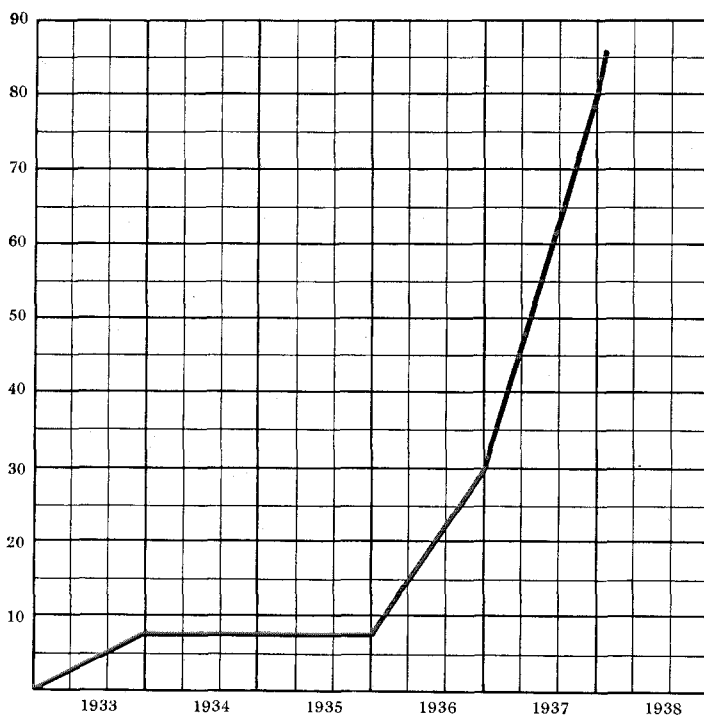

Fig. 7—Chart to illustrate rate of growth of demand for styrene barrier joints, terminations and plugs. This demand is at present rapidly increasing.

Because of the revolution in the art due to the discoveries mentioned above, viz., stabilisation by use of inhibitors, styrenated paper, cold process action, etc., it has not been possible so far to consolidate or to standardise effectively. It is not claimed that all the problems of joints and terminations have been solved and that the electrical characteristics, ageing characteristics, etc., observed in experimental work are of a fundamental nature. Rather it is claimed that since the basic principles are now very well understood it will be possible in the near future to solve the detailed problems which present themselves in connection with the variety of types of joint and termination encountered in commercial service. The economics of the process have been very considerably improved by the recent discoveries, so much so, that the joints designed even for low voltages bid fair to compete on a price basis with normal

oil or compound filled joints, independent of the question of provision of barrier action.

Figs. 6 and 7 indicate the growth of the commercial demand for such joints and terminations. It is significant that this demand is now rising rapidly.

One of the authors<sup>3</sup> has drawn attention to the interesting material produced by blending rubber and styrene. This material not only has application to extruded cables, but also is becoming of importance in jointing technique.

While pre-polymerised styrenated paper was being successfully applied to the case of joints and terminations, its possible application as a dielectric material for the general insulation of cables was also being explored. Basic electrical measurements indicated that the paper had an exceptionally low power factor at power frequencies, particularly at high temperatures, and a further interesting fact emerged, viz., that certain grades of the paper could readily be re-dried after humidification by the normal

process of applying vacuum at an elevated temperature.

The earliest experiments suggested application of the paper to low tension cables, e.g., those normally insulated with varnished cambric, in order to obtain improved electrical characteristics at temperatures of the order of 75°C. This led to consideration of its use in gas pressure cables in order to improve the thermal stability characteristic of this type of cable. Detailed study of the characteristics of the paper led to proposals for other applications, and it now appears that the applications of styrenation technique to cables themselves will overshadow the original applications to joints, etc., so that the latter will become relatively of minor importance. On the other hand, the widening of the field of application will tend to reduce the cost of styrene and of styrenated materials so that, economically, joints and terminations will gain thereby.

Discussions of high tension cables of various type employing styrene as part of the insulation will be deferred for a subsequent instalment of this paper, which is proposed for publication in an early issue of this journal.

<sup>3</sup> "Superstyrex," by T. R. Scott, *Electrical Communication*, July, 1937.

#### ERRATUM

*Electrical Communication*, Vol. 16, No. 3, January, 1938, page 282, "The Application of Styrene to H.T. Cable Systems."

For the formula in the second paragraph, the following should be substituted:

$$\frac{dv}{dt} = \frac{689\,000 \times 3\,600}{18\,300 \times 20 \times 4\,000}$$

$$= 1.7 \text{ cm}^3/\text{hour.}$$



## Recent Telecommunication Developments of Interest

*New "Standard" Medium Wave Broadcasting Equipment.*—The new "Standard" 10 kW Broadcasting Transmitter, recently developed by the New Southgate Laboratories of Standard Telephones and Cables, Ltd., combines economy in operation with the essential characteristics of extreme reliability and high fidelity, and the form of construction lends itself to rapid installation and facility of maintenance.

The economy in operation arises from the use of a high efficiency system of modulation, in this case final stage Class "B" modulation, and the excellence of the transmission characteristics is due to the application of reverse feed-back in the audio frequency system. The technique follows closely the methods already very successfully applied in recent "Standard" 100 kW transmitters.

The mechanical design exemplifies well the modern tendency towards unit construction and rational sectionalisation of the apparatus according to function, one advantage of which is the incorporation of standardised units used in transmitters of different powers with resulting

concentration of development effort and experience.

A valuable feature of the transmitter is the provision of reserve valves in the final high frequency and low frequency amplifiers and in the output stages of the high frequency and low frequency exciters, these being arranged to be cut in at a moment's notice. This facility is becoming a definite requirement in broadcasting transmitters of all powers.

The accommodation of reserve valves in the final stages has been facilitated in this transmitter, without a considerable increase of dimensions, by the method of mounting components on horizontal bars of low loss ceramic insulating material. This is more economical of space than the alternative method of mounting on vertical insulators and results also in a neat lay-out owing to the flexibility permissible in the disposition of components.

All valves, also a large proportion of the components, are easily accessible through the doors at the back of the cabinets. The remainder are accessible by the removal of the front panels

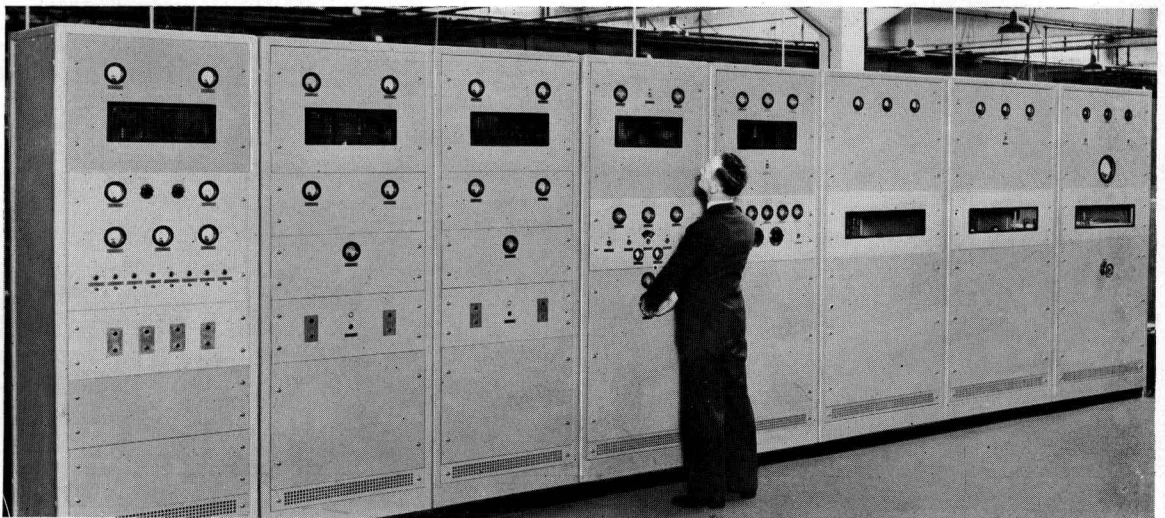

*New "Standard" 10 kW Broadcasting Transmitter. The units from left to right are : 1. Main control and grid bias rectifier unit ; 2. Exciter control and supply unit ; 3. Optional reserve exciter supply unit ; 4. High frequency exciter ; 5. Low frequency exciter ; 6. Low frequency power amplifier ; 7. High frequency power amplifier ; 8. Output circuit.*

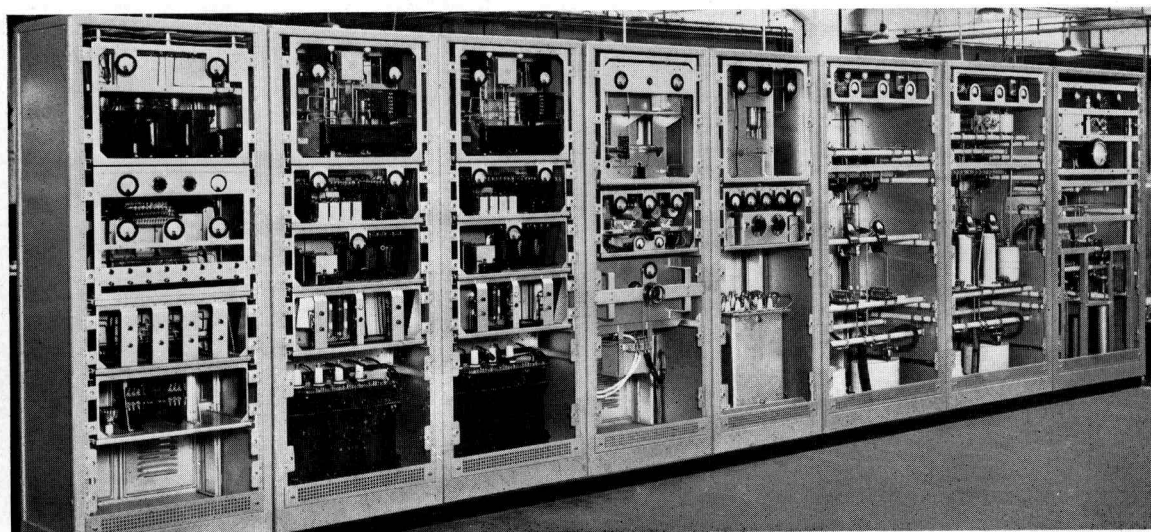

New "Standard" 10 kW Broadcasting Transmitter—Front view with panels removed. These panels are detachable without interference with the controls and meters.

which are designed to be easily detached. The equipment in the lower power sections is divided into separate self-contained chassis units which can easily be withdrawn from the main mountings.

The power amplifiers operate with a plate voltage of 9250 furnished by a six-tube hot cathode mercury vapour rectifier. Provision is made for the automatic reapplication of voltages in the event of a momentary overload or interruption of the main supply.

The 9250 volt rectifier and the modulation transformer and feed reactor are accommodated in a protected high tension enclosure situated behind the transmitter cabinets.

The plate circuit efficiency of the final high frequency and low frequency amplifiers together is 60 per cent. and the overall efficiency of the transmitter for carrier is 34 per cent.

• • •

*Berlin-Bogota and Lima Radio Telegraph Circuits ; Rome-Lima Radio Telegraph and Telephone Circuits.*—In May, 1938, direct radio telegraph circuits were opened between the Reichspostministerium Berlin radiotelegraph station and All America Cables, Inc. (an I.T. and T. subsidiary), radio telegraph stations at Bogota (Colombia) and Lima (Peru). These circuits carry traffic between Germany and beyond, and countries served by All America Cables in Central America, the West Indies

and the north and west coasts of South America.

A radio telegraph circuit also has been opened between the Rome station of the Italian Radio Company and All America Cables, Inc., radio station at Lima (Peru) to carry traffic between Italy and points beyond, and countries served by All America Cables in Central America, the West Indies and the north and west coasts of South America.

In addition, a radio telephone circuit has been established between the same Rome and Lima stations.

• • •

*Cine-Arc Selenium Rectifier.*—Le Matériel Téléphonique, Paris, recently developed a selenium rectifier unit for the supply of D.C. to cine projector arcs. These arc lights employ copper-plated carbons operating at 34 to 37 volts and drawing from 35 to 80 amperes, depending on the diameter of the carbons.

For either single-phase or three-phase supply, three units are available—40, 60 or 80 amperes. They are built up of the required number of single-phase or three-phase elements. The single-phase element consists of sixteen 112 mm. selenium discs in a full-wave circuit, four discs being included in each arm of a bridge. The three-phase element consists of eighteen 112 mm. selenium discs in a full-wave, three-phase circuit, which has six arms with three discs in each arm.

Since the use of oil-immersed rectifiers is objectionable in certain instances, L.M.T. has developed a unit with a case containing an air-cooled transformer, a rotary commutator (connected to primary taps) for adjustment of the arc current, and a rectifying unit. The latter is available either in oil-cooled form (immersed in a non-inflammable special oil) or air-cooled, employing special cooling fins. The first of these two alternative designs is reserved for low-priced rectifiers; the second is furnished where municipal authorities do not permit the use of oil-immersed apparatus.

In the oil-cooled design the 40, 60 and 80-ampere models contain, respectively, 2, 3 and 4 units (each rated at 20 amperes). The air-cooled design comprises 3, 4 or 5 special units with cooling fins (each rated at 15 amperes, approximately).

For cine-arc application, where dual projectors are used and where each projector is on 20 minutes and off 20 minutes, it is possible to run the discs safely at the above ratings. The average efficiency is 65 per cent. for the oil-cooled and 70 per cent. for the air-cooled design.

On the control panel of the case are an ammeter and the handle of the rotary commutator. A.C. and D.C. terminals are mounted inside the case.

The compactness of the design is illustrated by the following dimensions, which apply to the three-phase 60-ampere unit: width 60 cm., depth 48 cm., height 117 cm.

• • •

*R.22 Mobile Transmitter.*—Standard Telephones and Cables, Ltd., London, have developed a mobile telephone and telegraph radio transmitter (R.22) for portable or mobile

use. It is suitable for transport in light motor trucks, horse-drawn vehicles or by pack animals. It may be fitted for permanent operation in the vehicle or removed and operated on the ground. Its advantages are simplicity of installation and operation and shock-proof construction; further, it is tropically finished and therefore suitable for use in any climate. It can be erected and operated by unskilled personnel.

The wavelength range of 40 to 600 metres (7.5 Mc.–500 kc.) is covered in four bands with continuous tuning over the whole range. The master oscillator can be used as an auto oscillator or will provide four low temperature coefficient crystal-controlled spot wavelengths.

The frequency response is sensibly linear within  $\pm 3$  db from 200 to 6 000 p:s. Distortion is less than 5% at 80% modulation for any frequency between 300 and 5 000 p:s, while the noise level is 50 db below 80% modulation. For M.C.W. operation the modulating tone is approximately 1 000 p:s.

The carrier power delivered to the aerial circuit rises from 40 to 80 watts on C.W. and 10 to 20 watts on M.C.W. and telephony. The power consumption is 26 to 30 amps. from a 12-volt battery. Power may also be taken from a petrol-driven generator set.

The normal aerial system is a simple telescopic mast about 30 feet high, which weighs approximately 60 lb. (27 kg.) and which can be erected by one man in 30 seconds.

The complete transmitter is assembled in a metal chassis sliding into an aluminium box. The transmitter unit is  $11\frac{3}{4}$  in. high,  $18\frac{1}{4}$  in. long and  $11\frac{3}{4}$  in. deep (300 mm.  $\times$  464 mm.  $\times$  300 mm.). The weight of the transmitter unit with the cradle is about 40 lb. (18 kg.).

## Licensee Companies

BELL TELEPHONE MANUFACTURING COMPANY.....	<i>Antwerp, Belgium</i>
<i>Branches : Brussels</i>	
BELL TELEPHONE MANUFACTURING COMPANY.....	<i>Berne, Switzerland</i>
BELL TELEPHONE MANUFACTURING COMPANY.....	<i>The Hague, Holland</i>
CHINA ELECTRIC COMPANY, LIMITED.....	<i>Shanghai, China</i>
<i>Branches : Canton, Nanking, Tientsin.</i>	
COMPAGNIE DES TÉLÉPHONES THOMSON-HOUSTON.....	<i>Paris, France</i>
COMPAÑÍA RADIO AEREA MARITIMA ESPAÑOLA.....	<i>Madrid, Spain</i>
COMPAÑÍA STANDARD ELECTRIC ARGENTINA.....	<i>Buenos Aires, Argentina</i>
CREED AND COMPANY, LIMITED.....	<i>Croydon, England</i>
FABBRICA APPARECCHIATURE PER COMUNICAZIONE ELETTRICHE.....	<i>Milan, Italy</i>
<i>Branch : Rome.</i>	
INTERNATIONAL MARINE RADIO COMPANY, LIMITED.....	<i>London, England</i>
INTERNATIONAL STANDARD ELECTRIC CORPORATION, <i>Branch Office</i> ,....	<i>Rio de Janeiro, Brazil</i>
JUGOSLAVIAN STANDARD ELECTRIC COMPANY, LIMITED.....	<i>Belgrade, Yugoslavia</i>
KOLSTER-BRANDES, LIMITED.....	<i>Sidcup, England</i>
LE MATÉRIEL TÉLÉPHONIQUE.....	<i>Paris, France</i>
<i>Branch : Rabat, Morocco.</i>	
NIPPON DENKI KABUSHIKI KAISHA.....	<i>Tokyo, Japan</i>
<i>Branches : Osaka, Dairen, Taihoku.</i>	
SOCIÉTÉ ANONYME LES TÉLÉIMPRIMEURS.....	<i>Paris, France</i>
STANDARD ELECTRIC AKTIESELSKAB.....	<i>Copenhagen, Denmark</i>
STANDARD ELECTRIC COMPANY W POLSCE SKA z O. O.....	<i>Warsaw, Poland</i>
STANDARD ELECTRIC DOMS A SPOL.....	<i>Praha, Czechoslovakia</i>
<i>Branch : Bratislava.</i>	
STANDARD ELECTRICA.....	<i>Lisbon, Portugal</i>
STANDARD ELÉCTRICA, S.A.....	<i>Madrid, Spain</i>
<i>Branches : Barcelona, Santander.</i>	
STANDARD ELEKTRIZITÄTS-GESELLSCHAFT A.G.....	<i>Berlin, Germany</i>
STANDARD FABRICA DE TELEFOANE SI RADIO, S.A.....	<i>Bucharest, Rumania</i>
STANDARD TELEFON-OG KABELFABRIK A/S.....	<i>Oslo, Norway</i>
STANDARD TÉLÉPHONE ET RADIO, S.A. Zürich.....	<i>Zürich, Switzerland</i>
STANDARD TELEPHONES AND CABLES, LIMITED.....	<i>London, England</i>
<i>Branches : Glasgow, Leeds, Dublin, Cairo, Pretoria, Calcutta.</i>	
STANDARD TELEPHONES AND CABLES (PTY.), LIMITED.....	<i>Sydney, Australia</i>
<i>Branches : Melbourne ; Wellington, New Zealand.</i>	
STANDARD VILAMOSÁGI RÉSZVÉNY TÁRSASÁG.....	<i>Budapest, Hungary</i>
SUMITOMO ELECTRIC WIRE & CABLE WORKS, LIMITED.....	<i>Osaka, Japan</i>
VEREINIGTE TELEPHON- UND TELEGRAPHENFABRIKS AKTIEN-GESELLSCHAFT, CZEJKA, NISSL & CO.....	<i>Vienna, Austria</i>

*Sales Offices and Agencies Throughout the World*