



ELECTRICAL COMMUNICATION

JANUARY

No. 3

1937

VOL. 15

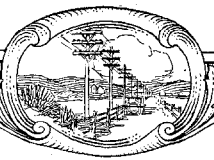

ELECTRICAL COMMUNICATION

A Journal of Progress in the
Telephone, Telegraph and Radio Art

H. T. KOHLHAAS, Editor

EDITORIAL BOARD

E. A. Brofos P. K. Condict G. Deakin E. M. Deloraine P. E. Erikson James E. Fullam
J. J. Gilbert F. Gill Frank C. Page H. M. Pease Kenneth E. Stockton

Published Quarterly by the

International Standard Electric Corporation

Head Offices

67 BROAD STREET, NEW YORK, N. Y., U. S. A.

European General Offices

CONNAUGHT HOUSE, ALDWYCH, LONDON, W. C. 2, ENGLAND

P. K. Condict, President

S. G. Ordway, Secretary

Joseph A. Redegeld, Treasurer

Subscription, \$3.00 per year; single copies 75 cents

Volume XV

JANUARY, 1937

Number 3

CONTENTS

	PAGE
ELECTRICAL COMMUNICATION IN 1936	177
ULTRA-SHORT WAVE RADIO LANDING BEAM—THE C. LORENZ- A.G. RADIO BEACON GUIDE BEAM SYSTEM	195
<i>By R. Elsner and E. Kramar</i>	
INSTALLATION OF RADIO DISTRIBUTION IN THE BEAUJON HOS- PITAL, PARIS	207
<i>By G. Meunier</i>	
PROPAGATION TESTS WITH MICRO-RAYS	211
<i>By A. G. Clavier</i>	
SOME EXAMPLES OF GROWTH CURVES	220
<i>By H. C. Plessing</i>	
X-RAYS IN VACUUM TUBE MANUFACTURE	224
<i>By W. T. Gibson and G. Rabuteau</i>	
AN EXPERIMENTAL TELEVISION TRANSMITTER	232
<i>By S. Van Mierlo and P. Gloess</i>	
AN EXPERIMENTAL TELEVISION RECEIVER	236
<i>By S. Van Mierlo and C. A. Pulles</i>	
POWER PLANTS FOR RURAL FULL AUTOMATIC OFFICES	239
<i>By V. C. Meeuws and H. B. Lee</i>	
PUBLIC ADDRESS INSTALLATION FOR THE PERFORMANCES OF "LE VRAY MISTÈRE DE LA PASSION" ON THE PLACE DU PARVIS IN FRONT OF NOTRE DAME CATHEDRAL, PARIS	251
<i>By G. Meunier</i>	
RECENT TELECOMMUNICATION DEVELOPMENTS OF INTEREST	259

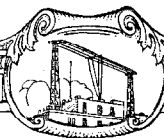

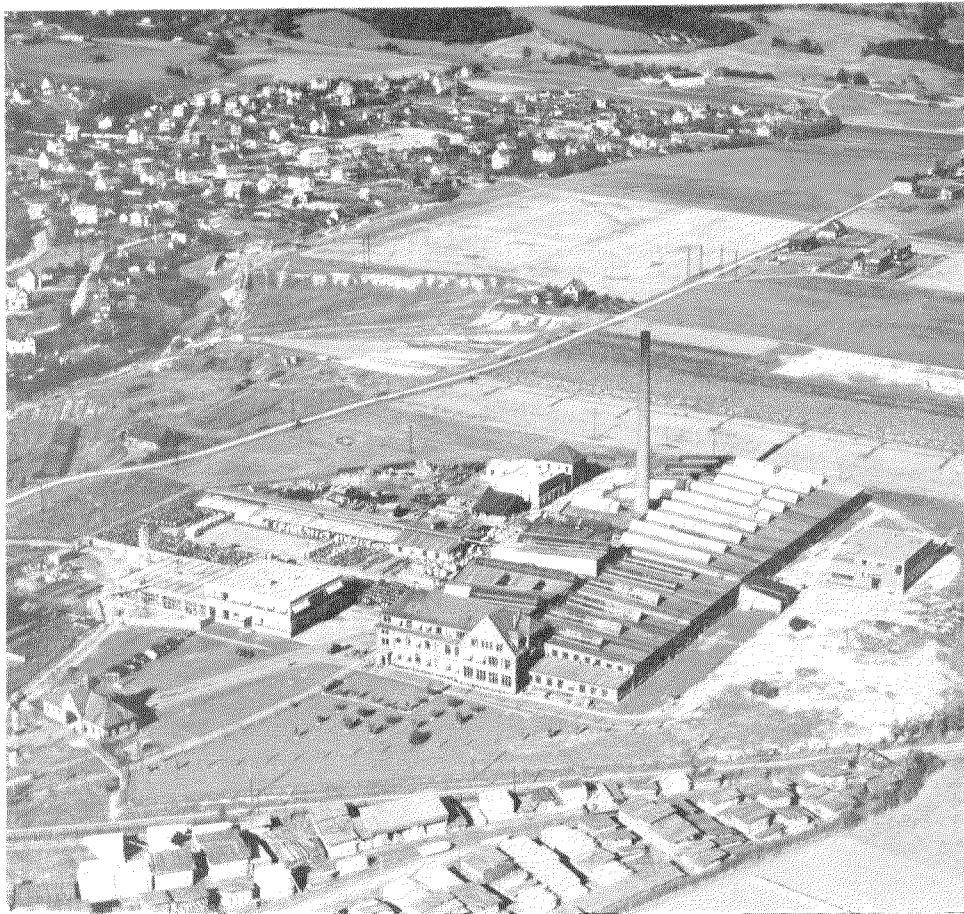

AIRPLANE VIEW OF THE MODERN PLANT OF STANDARD TELEFON-OG KABELFABRIK A/S, OSLO, NORWAY, FOR THE PRODUCTION OF BARE AND RUBBER INSULATED WIRE; TELEPHONE AND POWER CABLE; THE MANUFACTURE OF LOADING COILS; AND THE ASSEMBLY OF TELEPHONE APPARATUS AND EQUIPMENT. FLOOR SPACE OCCUPIED IS 150,000 SQUARE FEET AND THE SITE ON WHICH THE BUILDINGS ARE ERECTED CONTAINS 37 ACRES.

Electrical Communication in 1936

General Trend of Development

THE modern communication system is being formed increasingly by the progressive coordination of individual transmission paths of various types, capable of manual and more and more frequently of automatic selection and control. The means utilised for routing electric currents over such paths, together with adequate pick-up and reproduction facilities, provide the present day public with services which are continually improving in quality and expanding in variety: telephone, telegraph, facsimile, telephotography, teleprinter, etc.

In the switching field, the direction of development is in the provision of more complete automatic operation within areas of increasing size. The principal elements of such a problem are the long distance transmission of selective impulses, the control of the overall equivalent of the transmission path by means of the automatic insertion of repeaters with appropriate gains, and the recording of both the duration of the call and the tariff data involved. In certain cases alternate toll paths are automatically selected and the equivalent of manually prepared toll tickets containing all the pertinent information is printed automatically without the intervention of an operator.

These problems are solved principally by association of mechanical means with others adapted specifically to the transmission problem; the use of voice frequency currents for impulsing being predominant in the very long circuits, whilst for circuits of limited length lower frequencies are also used successfully. The problem of maintaining a given overall equivalent over complex circuits is one which may involve also the use of voice frequency signals destined to regulate the gain at given points.

The transmission paths themselves have been the object of a great deal of new thought during the last few years, due principally to the desire to obtain wider bands of communication. These wider bands may be made necessary by the

increasing complexity of the characteristics of the signals to be transmitted or by efforts to obtain lower costs for individual narrow bandwidths separated from each other in the wide band system by means of appropriate sharp filters.

These wide-band transmission systems necessarily use higher frequencies and involve special types of conductors often of larger overall size than those previously used. On account of the higher attenuation resulting from the use of these higher frequencies, the development of stable amplifiers giving high gains over wide bands has taken a very important place in research activities. Outstanding amongst these is the use of reverse feed-back amplifiers and possibly, in the future, the application of secondary emission phenomena to amplification of weak currents.

Another phase of these new developments is the search for means of filtering a band of frequencies out of the wide band system, leaving a minimum of lost space between two adjacent channels. One of the most promising methods is the application of structures involving quartz crystal elements giving very sharp cut-off even at the highest frequencies, and this new technique is likely to be of basic importance in future multi-channel communication systems.

The wide-band systems of to-day may be found inadequate, in the future, for use in connection with more refined methods of television or for very large groups of telephone or facsimile channels, and it is natural to consider the possibilities of systems using ultra-high frequencies. In this case, one may conceive guides which may have physical transverse dimensions of the same order of magnitude as the wavelength of the currents to be transmitted. The effect of a tubular conductor or solid dielectric structure is then to canalise the wave in the interior of the cylinder: a technique intermediate between ultra-short wave radio systems, where the energy is directed through free space; and that of wire transmission, where the metallic conductor acts as the carrier for the currents transmitted.

To a certain extent developments in radio transmission are paralleling those in the wire communication field. Wide-band systems are being actively developed for television transmission, facsimile or multiplex telephony. They employ ultra-short waves as carriers and involve, in some cases, the use of radio repeaters. Development is also proceeding in the hyper-frequency range applied to direct transmission without guide.

Apart from these problems involving essentially the transmission of intelligence from one point to another, a new general line of development is opened by the increasing demand for positional knowledge of mobile systems in space.

In general the problem of communication from ships or aircraft to ground systems has been solved, but further research is necessary to provide means of obtaining readily exact knowledge of the position of a ship or airplane.

The problem includes the creation in space of characteristic zones which give the navigator the information required, either for travelling from one point to another, for landing without visibility, or for entering a harbour. Part of this technique involves ultra-short wave systems and recent automatic goniometric methods eliminating errors due to reflected waves or other causes.

Another problem, which is also part of the technique in process of development, is that of the transformation of visual phenomena into electric waves and back. The acoustical equivalent is already highly perfected, particularly with the introduction of binaural perspective and high fidelity systems; but the technique of transformation of visible pictures into electric waves is of a much more complex nature and is only in its infancy. Very remarkable progress has been made by means of scanning by an electron beam a suitable granular photoelectric surface, thus resolving the visible pictures into electric currents. The inverse phenomena have also been produced with success by means of appropriate cathode ray tubes. Future years, however, undoubtedly will see many new additions to this technique.

The future of wide-band systems using very high frequencies is consequently of outstanding importance. This line of development involves complex phenomena due partly to the higher frequencies involved and also to the necessity of

measuring carefully quantities hitherto of secondary importance, such as the phase relationship of input and output currents in wide-band amplifiers for applying reverse feed-back, or the exact value of frequency and attenuation in a range for which measuring equipment so far has been very primitive. It would seem that much technical effort necessarily will be devoted to the elaboration of a measuring technique capable of coping with such new problems.

Progress in Communication Systems

Considerable activity has taken place in the extension and modernisation of European long distance systems, particularly in Great Britain.

During the year 85 new trunk cables to a total length of approximately 3,000 km., involving the construction of 1,600 km. of duct line, were provided in Great Britain. This represents an addition of approximately 600,000 km. of single wire to the British Post Office trunk system.

890 new inland trunk circuits, of over 40 km. in length, have been set up during the year. The longer routes show the larger increases, e.g., the number of trunks between London and Scotland has now reached 98, of which 55 have been provided since October, 1934. Between London and the West of England there are now 67 circuits, 55 of which have been provided since October, 1934. Nine additional Continental trunks, of which 5 are London-Paris circuits, have been brought into service during the year. Additional circuits were also provided for special occasions, the Olympic Games, Berlin, requiring 14 extra circuits, being an outstanding example.

Several important projects were completed and new construction started embodying the latest developments in the application of carrier telephony to underground cable systems. These included the complete laying of the London-Birmingham coaxial cable (290 km.)* designed for carrier telephony and television transmission, and the commencement of the extension of this cable to Manchester (210 km.). Included also is the Bristol-Plymouth non-loaded, multi-conductor, carrier cable* (involving two cables of 200 km. length) which has been completed together with the intermediate repeater and

* Developed and installed by Standard Telephones and Cables Ltd., London.

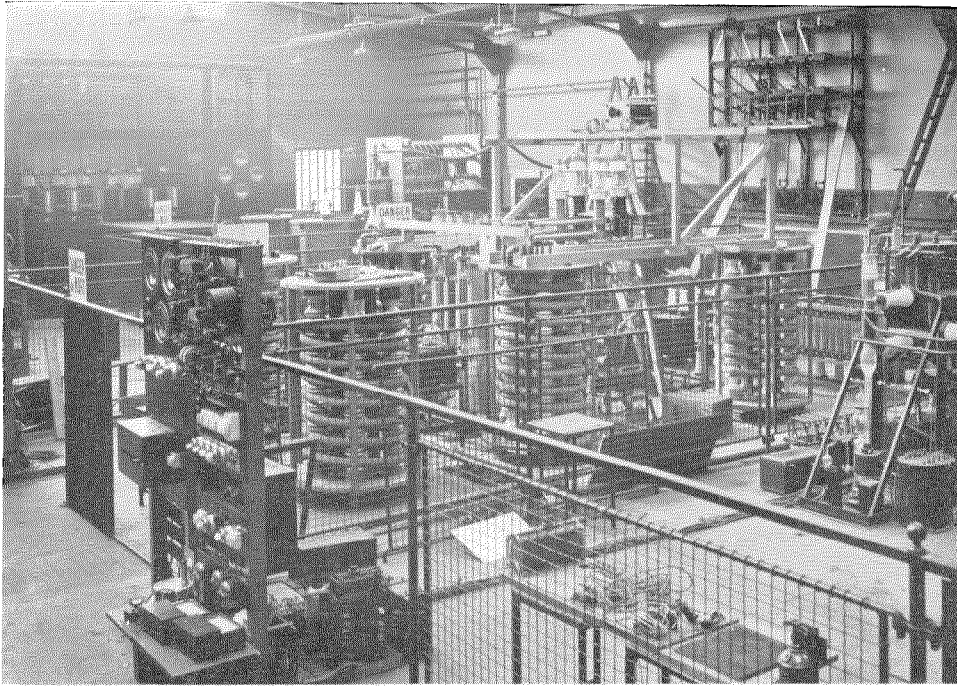

Part of Vacuum Tube Testing Laboratory, Les Laboratoires Le Matériel Téléphonique.

terminal equipments on a 12-channel carrier per pair basis for a large proportion of the available cable circuits. The repeaters are spaced at distances of about 32 km. along the route and are designed on the negative feed-back principle. Several additional cable systems of the same general design are already planned for installation.

The Czechoslovakian system has progressed according to the plans laid down in 1935, 105 km. of modern cable having been completed during the year with a further 122 km. under construction.

The Danish long distance system has recently been considerably extended. In addition to the 73 km. of cable completed, a further 221 km. is now under construction with additional projects in view for 1937.

The Netherlands Administration completed and has under construction considerable extensions to their long distance system, including cables for carrier telephone operation. A cable network for telephone purposes, comprising 153

km., was completed for the Provinciale Noord-Brabantsche Electricitats Maatschappij (a power company in Holland).

In Italy, projects of the P. & T. Department are proceeding normally. An important telephone cable for the Salerno-Reggio Railway, comprising 425 km. of track route, was completed.

Norway has made considerable progress in its long distance system. 175 km. of cable were completed during the year with a further 114 km. under construction. Part of the supplementary repeater equipment involved was also completed and placed in service.

Sweden has continued its usual heavy programme of underground cable construction. During the year, 516 km. of cable were installed, together with new and extended associated repeater equipments.

The Swiss Administration has devoted considerable attention to the problem of subscriber-to-subscriber dialing, and a successful demonstration of an automatic, 50-cycle, toll dialing

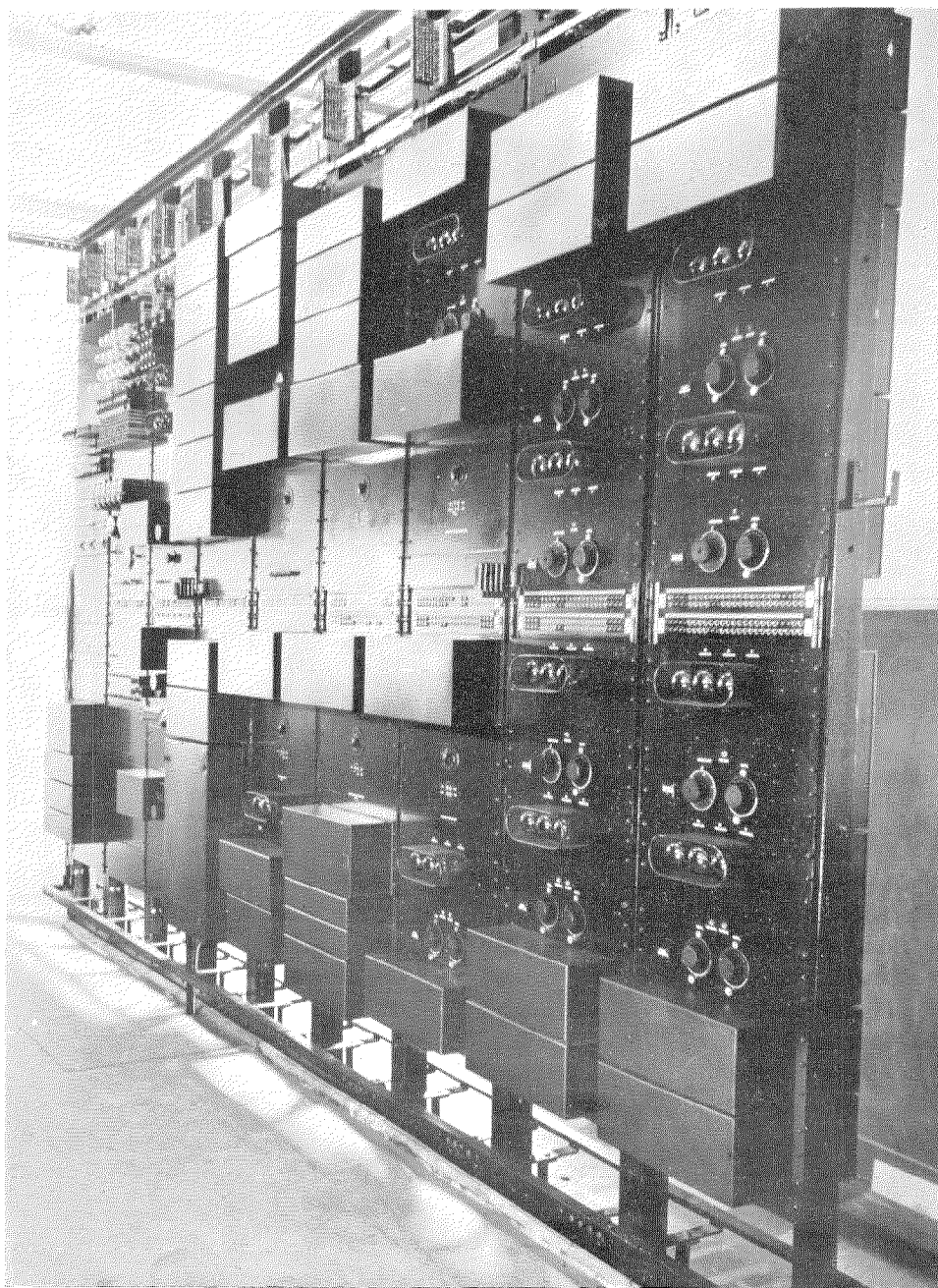

Cable Terminal Equipment at Stanley, Tasmania: Australia-Tasmania Submarine Cable.

scheme was given during the year over a section of the Swiss underground network. Extensions to the network comprised 95 km. of cable completed with a further 68 km. under construction.

The Australia-Tasmania submarine cable was successfully completed and put into service early in the year. This 180 mile cable is, incidentally, one of the longest submarine telephone cables in existence, and was designed for five telephone and seven duplex telegraph circuits, as well as for a special channel for the transmission of radio broadcast programmes. In both Victoria and New South Wales, Australia, steps are being taken towards the installation of underground toll cable systems; also, in Australia and New Zealand, to extend the use of carrier systems.

Extensions to the South African telephone cable network have been completed and new systems are contemplated.

In Germany, considerable activity occurred in the application of carrier telephony and television to coaxial cables as well as in extensions to loaded cable systems employing single channel and 3-channel carrier systems.

In France, progress continues to be made in the extension of the long distance telephone system. Approximately 450 km. of cable were placed in service during the year with a further 800 km. under construction.

Construction of the non-loaded cable circuit between Tokyo and Mukden—over 2700 km.—is making definite strides through the collaboration of Teishinsho (Japanese Telephone and Telegraph Administration), Korean Communication Bureau, and the Manchukuo Telephone and Telegraph Company. The first section Antung-Mukden, and the second section Osaka-Nagoya, were open early in 1936. Cable installations over the Seoul-Heijo and Fusan-Fukuoka sections have already been completed and the terminal and repeater equipments will be installed by March, 1937. The whole route is scheduled to be completed early in 1938.

All the terminals and repeater equipments for this project are specified to be the Nippon Electric Company's standard 3-channel non-loaded cable carrier telephone and repeater system. This system, which is intended for use on multi-core non-loaded cable is the result of extensive research in Japan and embodies many important improvements.

In Japan other toll communication networks are also becoming substantially complete through the active installation of inexpensive multi-channel carrier telephone and telegraph systems.

At Singapore, a 65 km. underground cable telephone system is now under construction.

Progress has been made by the Chinese Telephone Administration in furthering its long distance communication project, involving communication by wire between important points in a number of provinces. The installation of toll switchboards and repeater station equipment for operation over the newly constructed open-wire toll network was commenced at the beginning of 1936 and the first portion is now completed. There are to date five such installations: Shanghai, Nanking, Yingkiahwei, Kiukiang and Hankow. Standard Telephones and Cables Limited, London, manufactured the toll boards, repeater equipment, and the cables for river crossings.

The cutting into service of these equipments permitted the inauguration of telephone communication over land lines between Shanghai and Hankow, a distance of approximately 650 miles.

Plans have been prepared and the equipment ordered for the extension of this toll network. During 1937, seven or eight new toll switchboards and repeater stations will be installed and placed in operation, thereby establishing long distance telephony on a large scale in China.

There are indications that traffic over certain of the circuits already provided will increase in the very near future to such an extent as to necessitate the provision of additional circuits. The use of carrier telephony to provide these circuits is under serious consideration.

The Argentine State Railway Administration Headquarters at Buenos Aires is now provided with telephone and telegraph communication with the State Railway lines in Northern Argentina over a 3-channel carrier telephone and telegraph installation linking its Buenos Aires offices with the important terminal and division offices at Santa Fé, Añatuya, Tucumán, and Cruz del Eje, a route distance of over 1600 km. Voice frequency carrier telegraph is superimposed on one of the telephone channels between Buenos Aires, Santa Fé, and Tucumán on which Creed printers are used for handling messages. The carrier equipment was manufactured by Standard Telephones and Cables Limited, London, and

was installed by the Compañía Standard Electric Argentina and is one of the first installations of its kind in the world where 3-channel carrier telephony with superimposed voice frequency carrier telegraph has been applied to train despatching circuits.

Subscribers' Equipment

In the field of subscribers' sets, development is tending towards higher quality of transmitters and receivers as well as of the circuits themselves, with resulting elimination of noise, both extraneous and internal, in keeping with the efforts directed to removing noise from transmission systems and central office equipment.

The use of moulded local and common battery sets is being extended. Of particular interest is the advent of the convertible set introduced by the Bell Telephone Manufacturing Company, Antwerp. It offers the advantages of easy convertibility for use as a desk or wall set, as well as for local or common battery (either manual or automatic) working.

New and interesting developments in the P.A.B.X. field include an arrangement whereby two or three extension sets in multiple may call and intercommunicate with each other, ringing and talking current being supplied from the central office.

Further improvement has taken place in P.A.B.X. equipment with capacities ranging from 3 to 3,000 lines. New facilities and improved methods of operation have been embodied in attendants' sets and in the P.A.B.X.'s themselves.

To enable a P.A.B.X. subscriber to rapidly obtain connections without the necessity of dialing, the Bell Telephone Manufacturing Company, Antwerp, has recently developed an "Executive Rapid Call Equipment." Essentially it consists of a telephone set with a key box at the subscriber's station together with an adaptor circuit at the P.A.B.X., calls being made to a limited number of subscribers on the same board by merely pressing the key designated for a particular subscriber.

An interesting new development of Standard Electric, Budapest, is the so-called Home Coin Collector Box. It is attached to the subset and serves the purpose of preventing summer guests, boarders, or visitors from using the telephone without payment.



Subscriber Set Equipped with Budapest Home Coin Collector.

Remote Control and Signaling Systems

The application of remote control and indicating systems is being extended rapidly. Power Supply Authorities for large areas, either sparsely or densely populated, are finding it necessary to create within their own areas a central control point for control and remote indication of the major substations and the smaller lower voltage satellite substations. Owing to the large number of such stations, any remote control and indicating system to be attractive, must be relatively inexpensive and must occupy minimum space in the control room. A "Line Finder" system, meeting these requirements, has been developed. It provides the greatest possible flexibility for extensions.

Advances in railway signaling systems have continued, a notable instance in this connection being the Dial Train Control System which has been standardised by the L. & N. E. Railway of England. Systems have also been developed providing a method of indicating at some central point the position of a large number of track circuits (whether occupied or clear) over one common line channel.

It is apparent that the technique of railway signaling is undergoing a change, the most obvious result of which will be the gradual elimination of lever control of signal frames and the introduction of a system whereby the operation of the various points and signals is controlled from a desk provided with a track diagram.

A similar technique is also being employed in

the remote control of street lighting, remote indication of fuse ruptures, etc., etc.

Telegraph and Teleprinter Systems

Growth in telegraph traffic in Great Britain has been met by expansion of the 18-channel voice frequency system. The 4-channel system which was introduced in 1935 between London and Oxford has proved satisfactory and has been applied to other suitable routes.

An experimental 12-channel system was opened in January, 1936, between London and Paris and has been operated with success.

For use on V.F. systems generally, a static transmitting unit consisting essentially of a high grade transformer and a number of dry rectifiers in bridge formation has been introduced and will eventually be fitted on all "Standard" systems, thereby giving greater stability and economy in maintenance by eliminating the moving contact of the transmitting telegraph relay.

The use of teleprinters for handling telegraph traffic has now been generally adopted by Telegraph Administrations, and the C.C.I.T. has fixed the code and standards of performance required for machines used on International communication channels. Development work in 1936, therefore, was largely directed towards perfecting the design and manufacture of teleprinter systems in order to improve their performance and reduce maintenance costs.

A combined keyboard perforator and automatic tape transmitter* to provide Telex subscribers with a most efficient means of transmission in a convenient and compact form has been developed. The apparatus enables messages to be prepared in the form of a perforated paper tape before the initiation of a call. Keyboard operator delays are thus eliminated from the actual line transmission time, the messages being transmitted automatically at the maximum speed of the apparatus.

Teleprinter exchange subscribers in Great Britain have increased. Following the recent introduction of International Telex services, future growth is likely to be rapid.

A commercial Telex service was opened between Great Britain and Holland in May, 1936,

and a successful service was also maintained between Great Britain and the Olympic Stadium in Berlin during the 1936 Olympiad.

The C.C.I.T. and C.C.I.F. having adopted 1,500 p:s as the standard frequency for International Telex operation (on a single channel carrier basis), it was decided to convert the Inland Telex system in Great Britain from the frequency of 300 p:s previously used to 1,500 p:s.

The introduction of ancillary working in the British Inland Telegraph Service to cope more efficiently with the increase in traffic following the reduction of telegraph rates in 1935, has necessitated the provision in 1936 of a further 500 Creed teleprinters. These machines are fitted with answer-back units, especially developed for use in conjunction with the switching equipment, in order to dispense with the need for acknowledging telegrams as received.

Administrations in Europe and elsewhere are extending the use of teleprinters. In France, an additional 100 Creed teleprinters have been supplied for the National Telegraph Service. The Swedish National Telegraph News Services will increase their facilities by the addition of a total of 50 teleprinters.

Following the introduction in 1935 of the Johannesburg stock exchange service, which employs Creed teleprinters, a similar service was inaugurated in Sydney, Australia, in March, 1936, and similar services will be opened soon in Melbourne and Adelaide.

A teleprinter broadcast system has been developed for use in Great Britain to diffuse information on a full or partial broadcast basis; also a system for use in conjunction with standard P.B.X.'s. and apparatus on the ordinary telephone extension. In the latter case, when the lines are not required for broadcasting, the normal telephone and Telex facilities are available but, on operating the broadcast keys, the lines are transferred from the P.B.X. to the broadcasting equipment.

Radio Broadcasting

Attention continues to be focussed on improving the power efficiency of broadcasting transmitters. The use of high power modulation has been still further developed and it is now possible to obtain high efficiency, high fidelity, class "B" push-pull modulators incorporating

* Developed by Creed & Co.

"Black" feedback for carrier powers up to 100 kW. Another method of attacking the problem, put forward by the Bell Telephone Laboratories, is applicable to low power modulation systems and involves a power amplifier stage of two valves, one valve being connected directly to the output circuit and one through an impedance inverting network and operative only on the peaks of modulation. In a third line of development, all valves are driven at constant amplitude and high efficiency, the modulation being effected by combining the output of two amplifier systems with phase-modulated drives.

European broadcasting has exhibited a continuation of the tendency to operate all stations at high power, particularly in those cases where the station has sole use of a wavelength. An aerial power of 100 kW. is now common.

In Czechoslovakia, arrangements are being made for the installation of a new 100-kW. station and the replacement of a low power by a 100-kW. station which can be extended to 200 kW. Another 100-kW. station is contemplated.

Sweden is installing a new 100-kW. station and is contemplating further stations of similar size. In addition the network of low power relay stations in that country and in Norway is being extended to take care of the peculiar geographic problems encountered.

The advantages of the high mast radiator are being increasingly recognised and practically all new high power stations in Europe will be equipped with some radiator of this type.

A 910-foot Blaw-Knox radiator is being installed at Liblice, Czechoslovakia. It will be the second tallest mast in the world, the tallest being at Budapest. The new 100-kW. Czechoslovakian station will also have a vertical radiator of this type. The British Broadcasting Corporation now has two examples of such radiators, one in Northern Ireland and one at the new Scottish station at Burghead.

In connection with these mast radiators, the "shunt excitation" system introduced by the Bell Telephone Laboratories is of special interest. While it has hitherto been considered necessary to insulate mast aerials so as to apply the excitation in series with the mast, under this new scheme the mast is connected to ground and the power is applied through a short single wire transmission line to a point on the mast at some

height above ground of the order of one-tenth wavelength. This system considerably simplifies the provision of aircraft warning lights, now generally required on all high structures. Obviously, it may have appreciable economic reactions on the mechanical design and cost of the structure for a given height.

The British Broadcasting Corporation has continued the development of its scheme of distribution, and during the past year has put into service a number of high power stations to replace earlier and low powered stations. In addition to these developments in the B.B.C. "Home" service, a rapid expansion of the Empire service is taking place with the object of improving the strength and reliability of receptions from Daventry.

A new transmitter building has been erected at Daventry to house four high power short wave transmitters. Eight additional masts are being erected to support new aerial arrays, which have been designed as an outcome of experiments carried out since the Empire station at Daventry was placed in service in 1932.

Common wavelength frequency control equipment is being introduced on eight of the B.B.C. transmitters, and other European countries are studying this system as a means of solving the problem of wavelength congestion.

In Australia, the regional transmitters, installed by Standard Telephones and Cables Ltd. in the past year, are now coming into use and it is anticipated that further expansion of the service will be made to meet the public demand.

New Zealand is also increasing the power of its stations.

The Government of India have indicated their intention of proceeding with an extensive network of broadcasting stations, both medium and short wave.

It is understood that the two 150-kW. broadcasters for Tokyo station JOAK, the manufacture of which is reported to be almost complete, will be placed in operation in the Spring of 1937.

In connection with the regular international broadcasts by the Japan Broadcasting Association, the Japanese International Telephone Company ordered a new high power short wave transmitter and speech input equipment. The 50-kW. transmitter utilises low power modulation and is under test in the Nippon Electric Com-

pany's factory. It will shortly be installed in the Nazaki Station of the Japanese International Telephone Company.

The installation at Canton, southern China, of a 50-kW. broadcast station to replace the existing 1-kW. station is proceeding. It is anticipated that the new equipment will be ready for cutting into service early in 1937.

It is of interest to note that increasing use is being made of extremely short wave links for communication between broadcast networks and outside broadcast points which cannot normally be connected by wire.

Commercial Radio

Outstanding international radio telephone services inaugurated in 1936 include: Paris-New York; Tokyo-Shanghai; Tokyo-Cape Town (via London); and Tokyo-Rio de Janeiro (via Berlin). A similar service between Japan and French Indo-China also was started and negotiations are in process for a link between Tokyo and Bangkok.

Chinese authorities have been carrying out tests with England and America for the purpose of establishing radio telephone communication in the near future.

During 1936 short wave radio telephone links were established between Shanghai and Hankow, and between Shanghai and Canton. Facilities are provided for connecting the equipment at the terminals to the local telephone systems.

In the delta of the southern rivers in Kwangtung Province, China, a number of ultra-short wave equipments are being provided for telephone communication between various cities. The circuits radiate from Canton. Western Electric equipment is employed.

A radio telephone service between Great Britain and Kenya, East Africa, was inaugurated in March. Through submarine telephone cables Ceylon and Tasmania have been included in the international radio telephone network via India and Australia, respectively.

C. Lorenz-A.G., Berlin, provided an installation of four short wave transmitters for the Olympic Games in Berlin. These transmitters were the results of extensive development work and had to meet the following requirements: 40 kW. output in telephony; highest stability of frequency; percentage modulation 80%; and

quick changeability of wavelength. These transmitters form the focal point of the directional antenna system which directs programmes towards North, Central, and South America, Africa, and South and East Asia.

A considerable amount of experimental work on ultra-short waves continues to be carried out in all parts of the world. Evidence has been brought forward to show that on wavelengths below 250 cm. variations in atmospheric refraction or reflection (or both) from temperature inversion layers in the lower atmosphere may be definite factors in producing fading. Contrary to expectation, there also are indications that wavelengths between 5 and 10 metres may have a range of several thousand miles. In any case, equipments working in this band cannot always be considered as providing only a local field and the question of interference with remote stations may require attention.

Beginning with the latter half of the year, a 9-channel ultra-short wave link between Stranraer (Scotland) and Portpatrick (Ireland) has been operating on an experimental basis and is expected to be cut into regular service early in 1937. This link, which was ordered by the British Post Office to form part of its regular telephone network, will be the first single carrier, multi-channel radio link to be placed in commercial service.

An interesting radio telephone link is that to the island of Guernsey. This link employs 250-watt transmitters each handling two channels. The distance covered is 85 miles, approximately 1.7 times the optical range. Wavelengths of 5, $5\frac{1}{2}$, 8, and $8\frac{1}{2}$ metres are used.

Since the end of 1935, Teishinsho has been experimenting on the trial ultra-short wave telephone circuit over Tsugaru Strait (Aomori-Hakodate, 100 km.) with satisfactory results, using trial equipments. Recently an order has been issued for two transmitters with an output of about 50 watts and two receivers designed to provide six channels on one carrier utilising alternative wavelengths of 4 and 6 metres. The equipment is now under construction by the Nippon Electric Company.

A further application of ultra-short wave working is found in the Radio Corporation of America's experimental link set up between New York and Philadelphia. This link is intended to carry

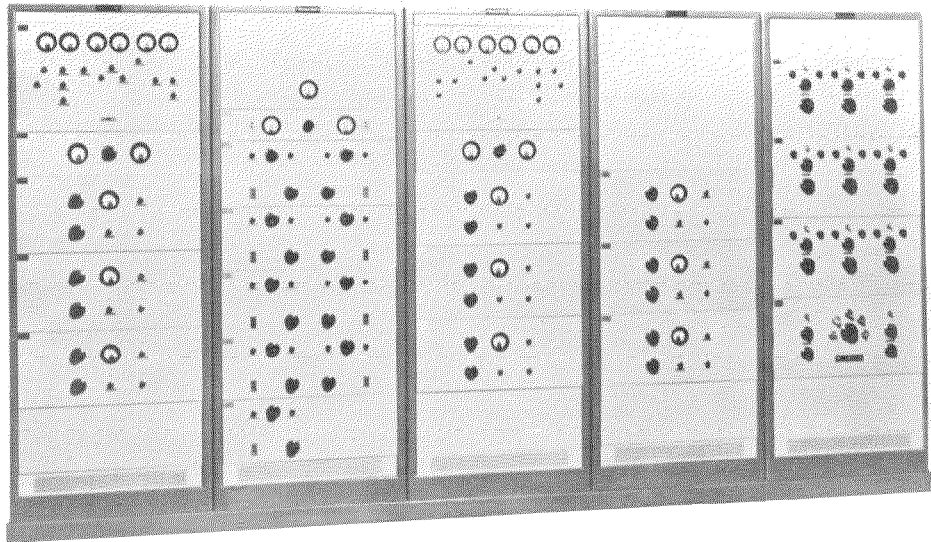

*Stranraer (Scotland) and Portpatrick (Ireland) 9-Channel Ultra-Short Wave Radio Telephone Link—
Transmitters and Channel Modulators.*

facsimile channels and uses 75-watt transmitters. The distance between the terminals of 91 miles is covered not in one step but with the introduction of two relay stations. The system operates on wavelengths of about 3 metres.

During 1936 an ultra-high frequency radio system was developed, installed, and placed in successful operation by the Mackay Radio and Telegraph Company between its New York central operating department and its main radio telegraph transmitting station at Brentwood, Long Island, for the remote control of radio transmitters by the central operating department, involving the use of a carrier frequency of about $3\frac{1}{2}$ metres and power of 80 watts, carrying six tone channels which it is intended to increase to eight in the future. Transmitters and receivers with semi-automatic switching facilities are installed in duplicate to ensure continuity of service. The distance from transmitter to receiver is 41 miles.

A number of new inventions and developments were made during the year on high frequency antenna systems, resulting in new types of radiation arrangements and tending towards

greater efficiency with lower capital costs. The resulting improvements were incorporated in the new antenna structures recently built by Mackay Radio.

Increasing interest is being shown in the use of ultra-short wave radio equipment for police use. The United Telephone and Telegraph Works, Ltd., Vienna, in conjunction with the Austrian police authorities successfully demonstrated such a system to representatives of many European police organisations.

Patent Suit

On October 14, 1936 the United States District Court, Eastern District of New York, handed down an opinion in a suit brought against the Mackay Radio and Telegraph Company for alleged infringement of five patents relating to directive antennas. The Court held that the antenna structures erected by Mackay Radio did not infringe any of the claims of the patents and that, furthermore, the antennas used by Mackay Radio were actually more efficient than could be constructed under the patents in the suit.

Television

The British Broadcasting Corporation are conducting commercial television transmissions on two systems: the E.M.I. (Marconi-H.M.V. group), and the Baird. Both these systems are installed at the B.B.C. television studios in Alexandra Palace and are employed alternately. The subjects televised include open-air shots, studio programmes, and films.

Some six of the larger British manufacturers are offering television receivers which range in price from about £85 to £120 and function on either of the two transmission systems employed by the B.B.C.

The French P.T.T. are transmitting one hour per day on an experimental basis. Direct pick-up transmissions are made from a studio at Rue de Grenelle. In the recent Paris Exhibition five television transmitters were shown in operation together with a large number of receivers.

French experimental telecinema emissions, using the same transmitter, will start early in 1937.

Les Laboratoires L.M.T. completed their second television system (the first was shown September, 1935). In cooperation with Le Matériel Téléphonique, this system was demonstrated at the Radio Exhibition. Motion picture films only were employed as programme sources.

The most recent demonstration of television in Italy was at Milan in April, 1936. The equipment employed electronic scanning for transmission and cathode ray tubes for reception. Research in Italy is being carried on in all details of transmission and reception, including the development of a suitable television transmitter to cover a service radius of 30 km. on a wavelength between 5 and 7 metres. For cine-films, 240 lines, 25 images per second were used. For daylight pick-up, 120 lines were employed. The receiver for combined vision and sound reproduction employed 13 valves.

The number of exhibits at the Berlin Radio Exhibition in 1936 indicated that development work on television is very active in Germany. The television transmitter at Witzleben, which is transmitting programmes two hours daily, is connected by means of coaxial cables to the Berlin television studios, to the site of the Olympic Games, and also to Nurnberg and Leipzig.

In the United States of America, the Radio Corporation of America have installed a television transmitter in the Empire State Building in New York City, connected by coaxial cable to the National Broadcasting Company's studios in the R.C.A. Building about a mile away. Experimental programmes are being broadcast from these studios.

Other American companies also are active in the field of television. The Bell System has installed an experimental coaxial cable system between New York and Philadelphia which will be available for television experiments.

Picture Transmission

Teishinsho, since 1935, had been experimenting with picture transmission over the 2,300 km. radio link between Tokyo and Taihoku, Formosa, employing Nippon Electric equipment. Encouraged by the results of the above transmission, Teishinsho, the Allied News, and Nippon Electric jointly undertook the first Europe-Asia radio picture transmission, taking the opportunity of the Eleventh Olympic Games held in Berlin in August. By arrangement with the

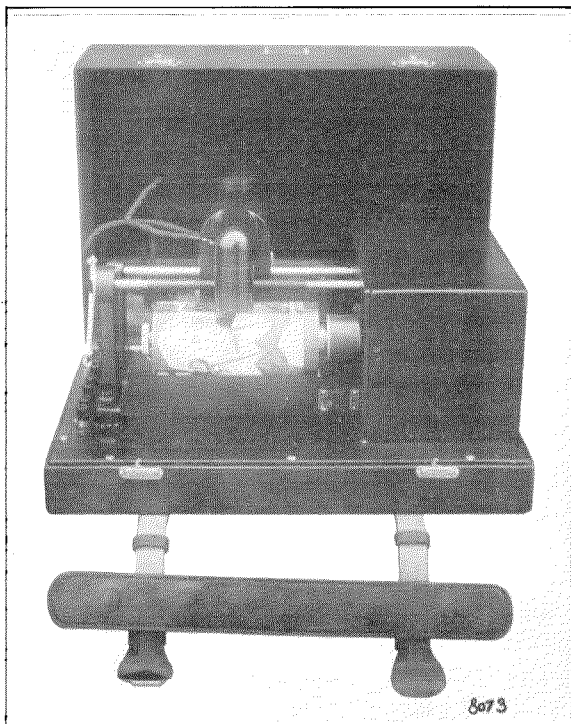

Nippon Electric Portable Picture Transmitter—Width, 402 mm.; Depth, 280 mm.; Height, 191 mm.

German Reichspost, Nippon Electric sent Japanese engineers and a complete set of No. 19-B radio picture transmission equipment to Berlin. This equipment is the newest model in which switching-over between time modulation and amplitude modulation can easily be performed as desired according to the conditions of the radio circuit.

The first part of the experiments was conducted with Nippon Electric's receiver in Tokyo and Siemens and Halske's transmitter in Berlin over the period from July 1st to August 17th. Time modulation system with a dot frequency of 170 cycles was employed for this experiment, and picture transmission was performed over a carrier circuit of 14,665 kc. between Nauen DFD Transmitting Station and Komuro Receiving Station, Japanese International Telephone Company, where two beam antennas for space diversity reception were used. Slight changes in the scanning density and speed of rotation were made in Tokyo in order that interworking between the Siemens and Nippon systems might be satisfactorily accomplished. The control operation from Tokyo was performed over a 15,750 kc. circuit. Pictures of the Olympic Games were printed in the Tokyo morning papers of the next day.

In the second part of the experiments, made during the three weeks that followed the Olympic Games, Nippon Electric equipments were used in Berlin and Tokyo and transmission was conducted in both directions. In this case both time modulation and amplitude modulation systems were employed with success. For the former system, an optical time modulation set employing a photo-cell was provided in the transmitter, and a special neon tube limiter was used for reception, while in the amplitude modulation the picture transmitter was coupled directly with the radio transmitter and a special device was fitted on the receiving side in order to minimise fading. High hopes are now entertained of the future of commercial picture transmission over radio links between Japan and Germany.

The transmitter was then moved to London, and the London-Tokyo trial transmission was started on November 17th with the collaboration of the British Post Office.

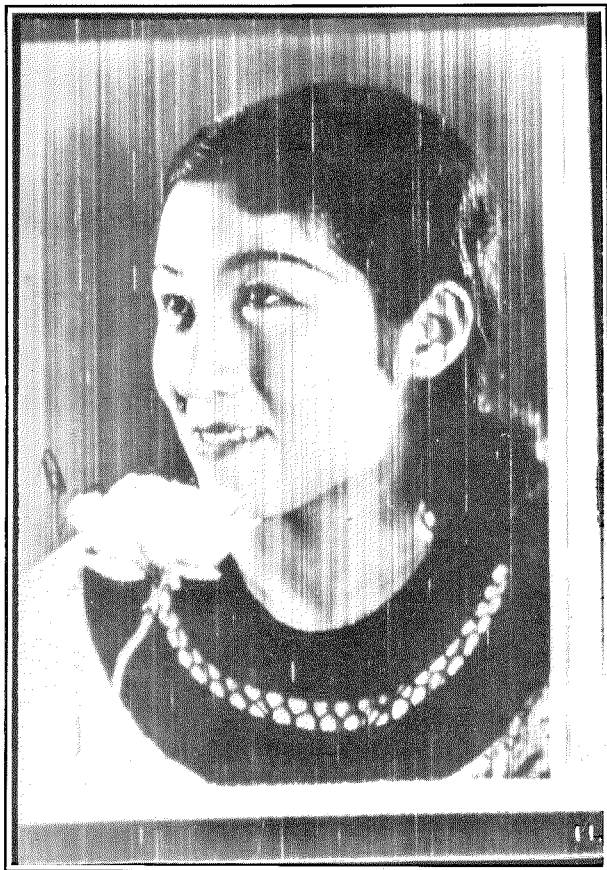

Picture Transmitted September 12, 1936, by Nippon Electric System from Berlin-Nauen DFD to Komuro-Tokyo. Received with Audio Automatic Volume Control using 2-Beam Antennas for Space Diversity Reception (Amplitude Modulation).

Marine and Aviation Radio

Marine. The unqualified success of the radio equipment* on the R.M.S. Queen Mary has been an outstanding event of 1936. It was only fitting that such a ship should be provided with an installation capable of meeting the demands of what promised to be a very remarkable maiden voyage. This promise was more than fulfilled; on this single voyage a radio telegraph traffic of over 275,000 paid words, 291 radio telephone calls to all parts of the world, and 40 separate broadcast programmes, made a record highly gratifying both to the equipment designers, the operating staff, and the Cunard White Star Line.

* "The Radio Installation on the Cunard White Star, R.M.S. Queen Mary," by H. Thorpe-Woods, H. H. Buttner, and E. N. Wendell, *Electrical Communication*, July, 1936.

This equipment includes a 3-kW. medium wave and a 3-kW. long wave transmitter together with two 400-watt short wave transmitters, all remotely controlled from the receiving room with respect to power, keying, and selection of spot wavelengths. The receiving room includes facilities for reception on 8 different channels simultaneously.

A new system of duplex transmission, which enables two messages to be sent simultaneously from one radio transmitter, has been tested from the Portishead Radio Station. The messages are transmitted on two neighbouring frequencies, separated by approximately 10 kc, by the use of a high speed thermionic switching device. The tests show that the system is workable and that satisfactory reception of either of the two messages is possible by the usual type of ship's receiver.

In April, 1936 Teishinsho installed a Nippon Electric short wave radio telephone equipment on the N.Y.K. liner S. S. Chichibu-Marun, and the first ship-to-shore service on the Pacific was opened to the public on August 8th with very satisfactory results. The equipment comprises a 2-kW short wave, crystal controlled transmitter, a 19-valve superheterodyne receiver (both operating on the frequency range of 4-20 megacycles) and a special 4-wire system telephone repeater which is provided with a CODAN apparatus. Beginning in November, the service was extended to include Canada, the United States, Cuba, and Mexico.

Teishinsho are now considering equipments for the S. S. Yasukuni-Marun, a more up-to-date N.Y.K. European service vessel, and the S. S. Asahi-Marun, a Tokyo-Formosan liner. The former vessel is tentatively scheduled to take the Imperial Party to England for the Coronation Ceremonies.

The Mackay Radio and Telegraph Company, in the field of ship equipment through the Laboratories of Federal Telegraph Company, has developed an automatic alarm receiver, also improved and simplified ship transmitters of low power primarily for emergency and life boat use, to meet the requirements of the Safety of Life at Sea Convention recently ratified by the United States Government.

Aviation. During recent years the increase in aircraft traffic has necessitated the use of more wavelengths and as many as six are employed for general aircraft navigation in Europe. The use of

these six wavelengths has naturally complicated the radio equipment. In addition short waves are employed for long distance routes, particularly in the tropics for communication with ground stations and between planes.

This increase of traffic has also necessitated the use of more than one airport at important terminals. At London, for instance, traffic is now brought in by the Croydon radio control to the Croydon controlled zone, and then handed over by radio to the Croydon, Heston, and Gatwick controlled zones for landing. Besides the instantaneous wavechange facilities for transmitters and receivers, this system has also necessitated the fitting of each of these airports with Lorenz blind approach equipment and the equipping of aircraft approaching Croydon with three-wavelength ultra-short wave receivers.

In order that navigators may be able to find their positions immediately most Aviation Operating Companies are now fitting direction finding apparatus on the aircraft, thus making direction finding work independent of the airports and enabling the latter to deal with more traffic.

Since the introduction of direction finding apparatus on aircraft, and the allocation of yet another wavelength for broadcasting weather reports, there is a tendency to use more than one receiver. The pilot thus may receive weather reports independently of the normal communication channel. Each of these receivers, if necessary, acts as a spare for the other in case of emergency.

The extension of the Imperial Airways services through the British Empire has involved the provision of many new ground stations for direction finding and for communication purposes along the various routes. Particular attention must be paid to the importance of radio on the Pan-American Airways' transpacific route, which involves "hops" of between 1,200 miles and 2,400 miles. On this route the position of the machine is determined every half hour by means of ground direction finding stations operating on the Adcock basis. Owing to the length of the "hops," it has been necessary habitually to take bearings at distances far beyond those hitherto considered reasonable.

The success of the Lorenz blind approach system is demonstrated by the fact that equipments have been, or are being, installed in a number of important airports throughout the world.

An extensive ground station network involving

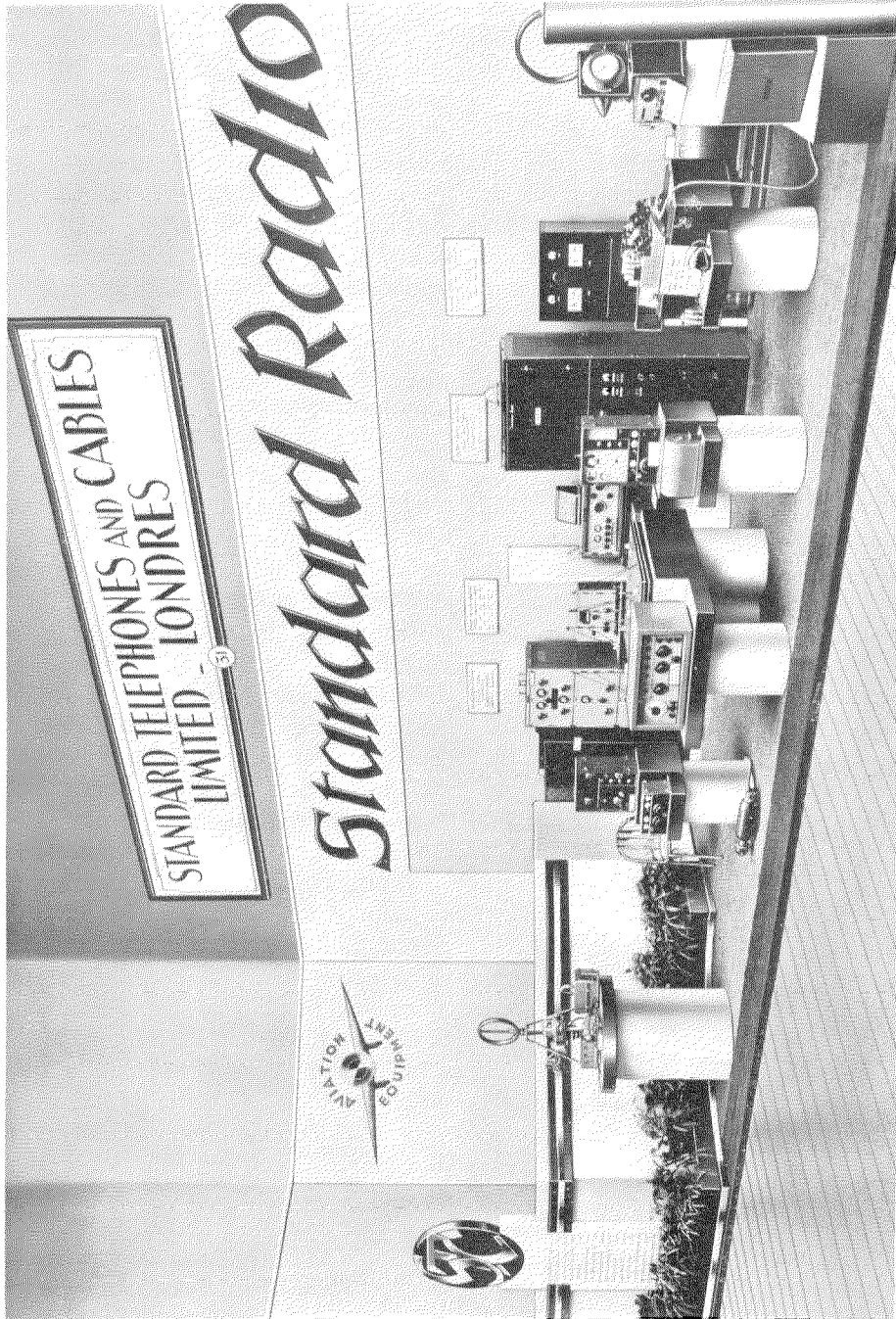

STANDARD RADIO STAND—PARIS EXHIBITION

Norway, Sweden, and Finland is in course of installation. In addition to normal communication facilities, Adcock direction finding and blind approach systems will be included. In South Africa a network of ground stations, including Adcock direction finders, has been completed.

The Air France route to South America is now being completely equipped with Adcock direction finding stations.

At the International Aviation Show held in Paris in November, the French Air Ministry exhibit gave prominence to the R.C. 5 Radio Compass,* a model of which was displayed. In addition a small scale model showing the installation of an R.C. 6 Ground Direction Finder was on view. The fighter aircraft set of Standard Telephones and Cables Ltd., London, also attracted a good deal of interest since it was the only electrically remote-controlled set exhibited.

Rotary and Automatic Ticketing

The conversion of the Paris telephone network from manual to automatic, started in 1928, is now virtually complete, the whole of the Paris city area being on a full automatic basis with the exception of one office (8,000 lines to be cut over in 1937). There are 37 offices equipped for 330,000 lines.

The Paris suburban area comprises seventeen offices (equipped for 63,900 lines) either in service, under construction, or in process of installation. In the city area 25 offices (214,000 lines) and in the suburban area 10 offices (39,600 lines) were supplied by Le Matériel Téléphonique.

The Paris automatic telephone network will be extended to include the Paris regional area, designated "Zone No. 1," which takes in all places situated within a radius of 25-30 km. from Paris.

History was made on December 7, 1936 when the first installation for the automatic ticketing of toll calls was put into commercial operation by the Belgian Government. As its name implies, the system produces automatically a ticket on which is recorded the number of the calling party, the number of the called party, together with the town prefix, the rate, the duration of the conversation in minutes, the time, and the date.

* "The Automatic Radio Compass and Its Applications to Aerial Navigation," by H. Busignies, *Electrical Communication*, October, 1936.

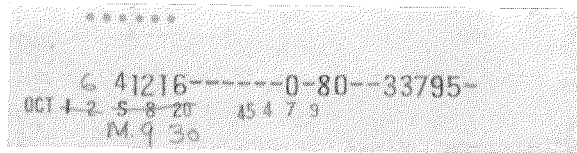

First Ticket Charged by the Belgian Administration with the Aid of the New Automatic Toll Printing Register. The Corrections are Due to the Fact that the Ticket was Printed while the Equipment was still under Test and the Machines were not all set to the Correct Date and Hour.

The system has been designed as an integral part of the rotary automatic system and may be easily applied to existing rotary type exchanges which were installed long before automatic ticketing was thought to be commercially practicable. In fact, this first installation was added to the Rotary 7-D Exchange in Bruges and to similar exchanges along the Belgian coast where a multitude of visitors from all over Europe congregate during the summer season. Because of this great influx of visitors, the seasonal variation in traffic is very great. With automatic toll ticketing, variations in regional traffic make little difference since there is no manual operating force to adjust to meet the changing traffic conditions. The success of this first installation resulted in the Belgian Administration placing orders for the extension of the system in the Bruges area.

Automatic toll ticketing may be applied to various purposes and in whole or in part. For example, it may be used generally in connection with suburban services to avoid the making out of a multitude of tickets for low-priced calls. On the other hand, it may be applied to a limited extent in connection with international or long distance calls, in which event it is not necessary to utilise identification equipment or make the recording equipment available to more than a few groups of important subscribers desiring international or long haul toll service on a full automatic basis. Examples of such subscribers are banks, exchanges, and important commercial houses having frequent occasion to telephone, say, from Brussels to Paris.

The development of automatic ticketing is the joint effort of the laboratories of the Bell Telephone Manufacturing Company, Antwerp, and Les Laboratoires L.M.T., Paris.

The rotary automatic system is now installed

in 815 exchanges in 39 countries and the total lines installed or on order at the end of 1936 exceeded 1,960,000.

During 1936 six digit dialing was introduced in the Budapest automatic telephone area.

National Dialing

A field trial of the rotary automatic toll system was carried out in Switzerland between the towns of Faido and Zurich. The cable circuit was built up by loops to total approximately 800 km., and equipment was put into service to represent an originating and terminating toll exchange with two intermediate tandem exchanges. Included were six standard two-wire repeaters with two of these repeaters connected automatically at the tandem points. For dialing, the new low voltage 50-cycle signaling system was used.*

The field trial was in every way satisfactory and equipment for a new full automatic toll exchange in Zurich was ordered by the Administration. Expressed in number of toll lines, switching and signaling equipment is foreseen for a total of 880 toll lines with the possibility of growing to three times this number.

The rotary automatic toll system was also demonstrated in Haarlem, Holland, in which country national dialing is also moving ahead.

Step-By-Step

The increase in the number of new subscribers of the British Post Office in 1936 was 416,000 as compared with 350,000 in 1935; the net increase was 230,000 in 1936 as compared with 180,000 in 1935.

The automatization of exchange plant in Great Britain has been greatly accelerated. The number of automatic exchanges opened during the twelve months ending September, 1935, totaled 258, including 51 major exchanges. This figure is exactly twice that for the previous twelve months. For rural areas three sizes of unit automatic exchanges have been standardized, namely, 100-, 200-, and 800-line exchange types. All these types incorporate the new Post Office relay, and the two larger sizes also include the new Post Office standard 2-motion selector.

* "A Field Trial of 50 Cycle Signaling on Toll Lines," by W. Hatton, *Electrical Communication*, October, 1936.

To improve the quality of the various tone signals in automatic exchanges and to obtain a greater measure of uniformity in these tones, an inductor tone machine has been developed to replace the tone drums hitherto used.

Equipment installed experimentally in the Folkestone automatic area to replace the "number engaged" tone by an aural announcement of the word "engaged" has had the effect of reducing from 11 seconds to 6.5 seconds the period the switches are held by the subscriber after the application of the engaged signal. The extension of this facility to trunk and toll calls is now under consideration.

Automatic traffic recorders, which record automatically the amount of traffic handled by a group of automatic switches, have been developed, and are now being installed at all except the smallest type of automatic exchange. This will enable a closer watch to be kept on the growth of traffic, and thus ensure adequate provision of switching plant at all times.

A speaking clock was made available to London subscribers in July, 1936. Subscribers on manual exchanges by asking the operator for "time" and subscribers on automatic exchanges by dialing "TIM," are connected to the clock and hear the time announced accurately to within 1/10th second. Calls are now ten times the number made previously, and in view of the evident utility of the service its extension to other areas is under consideration.

Installation of automatic telephone exchanges in Japan is making continuous progress. During the year fourteen step-by-step exchanges, with a total capacity of 53,200 lines, were opened by Teishinsho.

Increase in private branch exchange installations in Japan during 1936 is estimated to be at least 30,000 lines.

An important addition has been made to the Buenos Aires terminal communication network of the Buenos Aires Great Southern and Buenos Aires Western Railways, now working under joint management. This addition consists of three exchanges of 250, 150, and 80 lines, respectively, which interwork with the existing 300-line 7-B Rotary automatic exchange at the Plaza Constitucion office. The entire network of 780 lines is one of the largest privately owned automatic P.B.X. systems in South America.

International Telephone and Telegraph Corporation Operating Companies

Based on preliminary results for the year 1936, eight of the subsidiary Operating Companies of the I. T. & T. show station gain greater than in the corresponding period of 1935. The 1935 station gain figures, incidentally, were exceeded only by those of 1929 and 1930. In 1935 the gain was 58,000 telephones, while in 1936 it was slightly over 72,000 telephones. (The 1936 gain includes only the first six months' results of the Spanish Telephone Company, as they are the latest data available.) Every major company showed a substantial gain for the year, with the companies in Argentine, Rumania, Chile, Shanghai, Cuba, Mexico, Porto Rico, and Peru contributing most heavily. The toll traffic handled by these companies was the best in their history and estimates are that (exclusive of the Spanish Telephone Company) the results for 1936 will surpass those for 1935 by 12.3%.

In all these companies, plant extensions were carried out during 1936 to meet the increased demand for service. Important new toll lines were constructed and the capacity of existing lines in several territories was increased by the application of carrier systems.

A line constructed from Antofagasta, Chile, to Iquique connected the telephone system of the latter for the first time to the national Chilean network, and thus to the international network.

In September, 1936 the City of Lima, Peru, joined the ranks of cities which have an entirely automatic telephone system. As a result of further additions to automatic equipment during the year, every provincial capital city of Cuba is now on a full automatic basis. Four new dial central offices were added to the United River Plate system in Argentina and various magneto offices in the outlying sections of the country were converted to common battery working. An important dial installation took place in Porto Alegre, southern Brazil, and further progress was made with the automatic programme in Chile and Rumania.

Three important radio telephone extensions during 1936 involved these International subsidiary companies. The inauguration of service between the United States and Porto Rico in February, 1936, is of special interest because of

the large trade with Porto Rico and the rapidly growing tourist interest in this Island. Radio service also was opened between Porto Rico and Santo Domingo; also between Lima, Peru and Antofagasta, Chile.

Power Line Carrier

About twenty terminal equipments for power line carrier telephone systems have been supplied by the Nippon Electric Company during the year to several power companies. The systems employ different frequencies for opposite directions of traffic and the carrier frequencies are not suppressed. In addition to the stability of performance achieved by an automatic volume control, much higher quality of transmission has been obtained by the use of greatly improved filters.

Power Transmission

In the field of underground power cable, the greatest interest is directed to transmission at the highest voltages. To this end there have been put forward in the past few years various designs which permit a more economical utilisation of material at the expense of a more severe stressing of its electrical properties. This is rendered feasible by the ensured maintenance of a minimum fluid pressure on the impregnated paper dielectric. The sheath thus becomes involved in a new function while the simplicity of the normal type of solid core cable is sacrificed.

At the higher voltages the employment of these pressure devices has hitherto been considered essential, but the upper limit to the economical employment of solid type cable promises to be raised by the development of internally compensated intersheath cables in which the maximum electrical stresses are reduced by the configuration adopted in the design.

In high voltage cables, progress has been made in achieving a greater compactness of the active dielectric by the selection of more suitable materials and by improved paper-lapping methods, by the elimination of adulterants such as oxidation and acid products as well as moisture, and by the reduction of the gaseous content of the cable through improved impregnation methods.

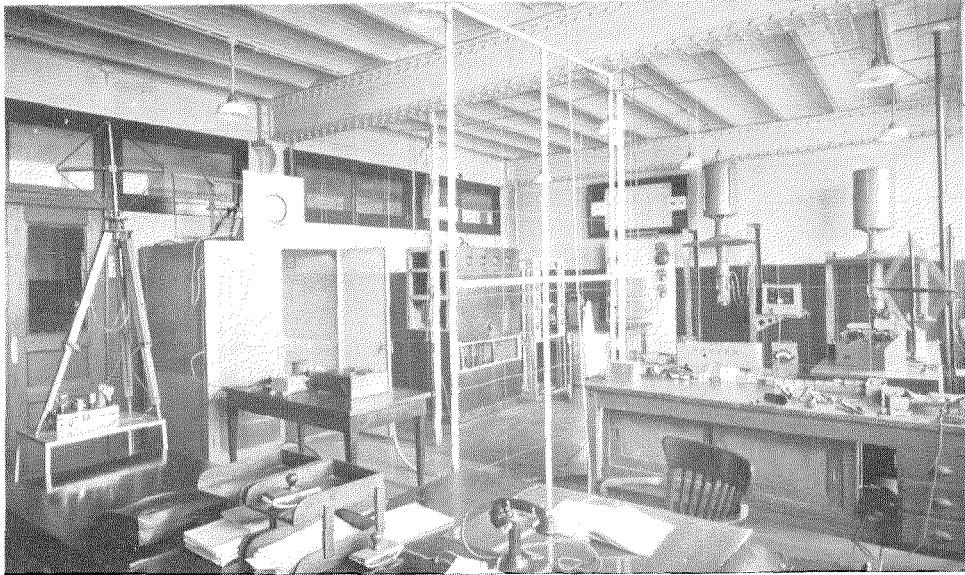

Radio Direction Finding Laboratory, Les Laboratoires Le Matériel Téléphonique.

The application of fluid pressure to cables has called attention to the need in special cases for barrer joints for preventing the migration of compound or limiting the pressures set up within the cable. The development of the "Styrene Joint" offers many advantages, both electrical and dimensional, over the more conventional type of stop-joint.

A "dry core" type of power cable working at high gas pressure has been proposed. This type of cable would to some extent bridge the gap between telephone and power cable practice and might find application in both fields.

Bell's 60th Anniversary in Japan

Early in June, 1936, the Japanese Institute of Telephone and Telegraph Engineers, allied with Teishinsho, held a convention and exhibition at the Mitsukoshi Department Store in Tokyo to celebrate the 60th Anniversary of Alexander Graham Bell's invention of the telephone. During the course of the exhibition Mr. T. Kajii, Director General of Teishinsho, gave a popular lecture on the history of Japan's communication systems. In addition, Teishinsho and many of the communication manufacturing companies supplied equipments for public demonstration.

Ultra-Short Wave Radio Landing Beam

The C. Lorenz-A.G. Radio Beacon Guide Beam System

By R. ELSNER AND E. KRAMAR,

C. Lorenz-A.G., Berlin-Tempelhof, Germany

WITH modern methods of aerial navigation and growing air traffic density, electrical landing facilities are of constantly increasing importance. Under unfavorable weather conditions they are indispensable to successful aircraft operation.

Preliminary to a description of the essential advantages of the C. Lorenz-A.G. ultra-short wave system, it may be stated that basically, it provides radio telegraph reception indicating the approach path to the airport and, similarly, two distance markers governing the landing process. When developing the system, the guiding principle was to employ radio only for such purposes as could not be accomplished by other means, and at the same time provide a receiver which

would be electrically independent of that used for communication purposes, thus reducing the manipulation on board to a minimum. In view of these considerations and with due regard to factors such as interference from landing beacons of neighboring airports, the operating frequency had to be chosen. Because of their definitely determined operating ranges, only frequencies over 30 megacycles could be considered, both for the radio beacon itself and for the marker beacons.

The direction of approach in the C. Lorenz-A.G. system is based on the beacon principle, giving side or boundary indication of the landing path; and, also, at two points along this path, signals serving as distance markers, and indicat-

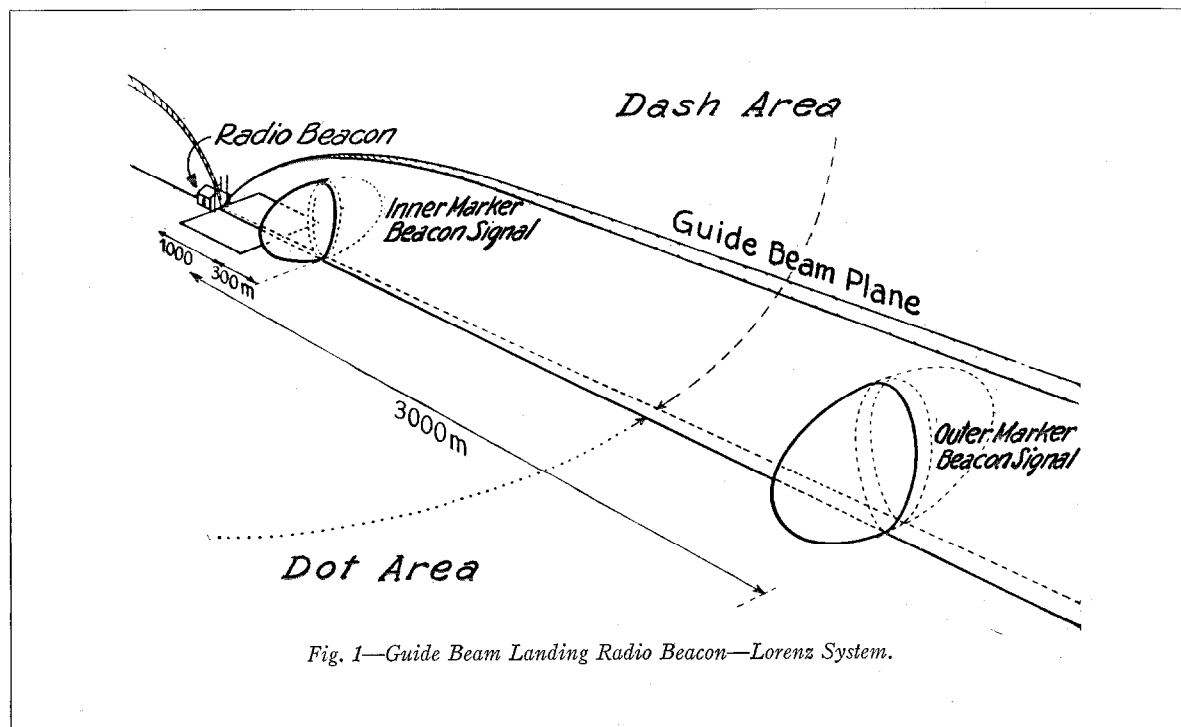

Fig. 1—Guide Beam Landing Radio Beacon—Lorenz System.

ing to the pilot the distance of the machine from the landing field (Fig. 1).

Ultra-short waves, with their lines of constant field strength, may be utilized under specific circumstances in vertical navigation as electrical landing curves; but they have not been thus applied in Germany during the last part of the landing process despite the fact that experiments have indicated their practicability under certain conditions. Difficulties in their application lie mainly in the fact that the course of their curve does not correspond to the natural glide path. These difficulties have been overcome with the help of clockwork regulating instruments which reshape the normal indication obtained by means of the beam into a straight glide path. The experimentally tested glide path (Gleitweg) process, with due regard to certain attendant circumstances, can be utilized as, for example, in Switzerland, where the glide path is followed down within a few meters from the ground.

The equipment of the ground station is the same, irrespective of whether the method of electrical vertical navigation is employed or that at present utilized in Germany, viz., of landing at a constant rate of descent (Fig. 2).

Outline of the Approach and Landing Process in the C. Lorenz-A.G. Ultra-Short Wave Guiding Beam System

If, in consequence of poor visibility due to fog or other conditions, landing by means of a radio beacon beam is necessary, the pilot guides his machine to the vicinity of the airport (a zone of approximately 30 km. radius) by existing means of direction finding or homing. By means of the tone modulated signals radiated by the main beacon, he reaches the approach path marked by this beacon. For the reception of the beacon signals an automatically operating receiver is used, furnishing the pilot with both aural and visual indication of the position in the horizontal plane of the machine with respect to the guiding beam of the radio beacon. The approach path sector, as is well known, is defined by the intersection of two radiation diagrams produced by the alternate operation of two reflector dipoles (Fig. 3). Should the airplane be outside of this approach path, short dots are heard on the port side, or dashes on the starboard side. Diver-

gencies off the course are again indicated both aurally and visually (Fig. 4). By intermittent deflections to left or right of the received signal, the indicating instrument shows the direction in which the pilot should steer his machine in order to reach the approach path in which the (complementary) signals, by merging into one another, become a continuous note. At the moment when the continuous note is reached, the direction indicator comes to rest and indicates to the pilot that he should maintain his course for a safe landing at his destination.

During the approach, the pilot gradually decreases his height to about 200 meters. At about 3 km. from the boundary of the landing field when reaching the outer marker beacon signal, lamp ("V") on the left-hand side of the visual indicator apparatus lights up and, at the same time, a deep note (700 p : s) is heard in the headphones. The pilot then throttles back and gliding down at an approximately constant rate of descent reaches the admissible minimum height at the inner marker beacon. The inner marker beacon signal is given at a distance of 0.3 km. from the boundary of the landing field—a few seconds before the machine reaches this boundary—and is conveyed to the pilot by a rhythmic short-keyed high note as well as by the lighting of the right-hand lamp H in the visual indicator equipment. The pilot now knows that there are no obstacles to his flight in the final section of the landing path and can, consequently, further reduce the height of flight in order that he may bring his machine down safely even when ground visibility is at its worst.

This briefly described landing method is used to a very great extent in Central European traffic. It consists in the determination of the approach course to the airport as well as in the transmission of signals which mark two important distances from the boundary of the landing field and which are involved in the process of landing. This landing method, employing landing beacon beams of the type used in the C. Lorenz-A.G. ultra-short wave system, is being increasingly applied in European air traffic.

The Design of the C. Lorenz-A.G. System

The Lorenz system of navigation necessitates a "ground station" at the airport, and the installa-

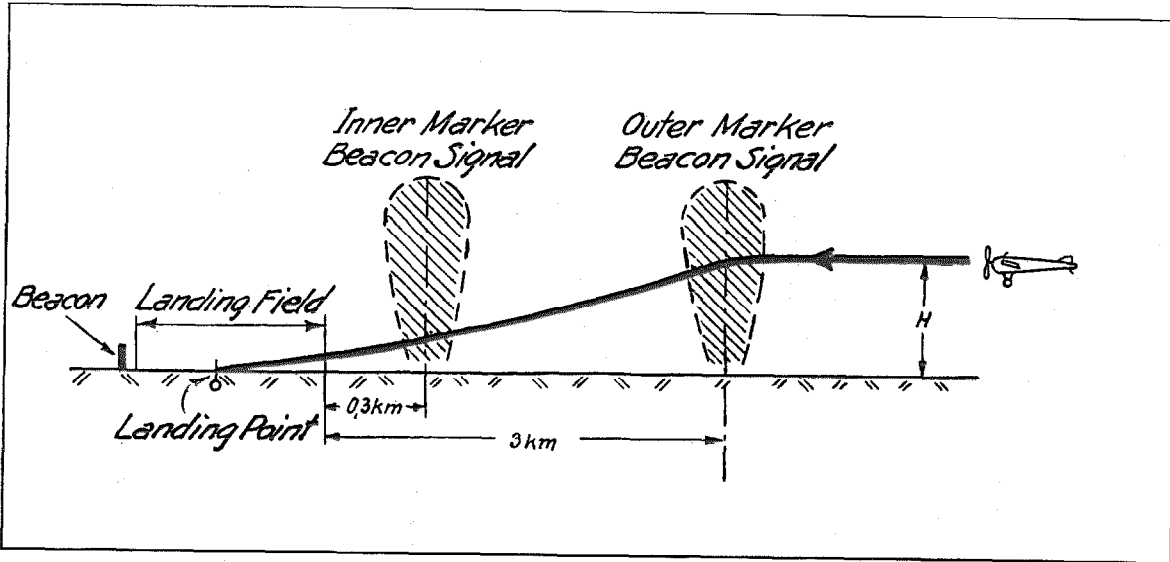

Fig. 2—Schematic Arrangements of Landing Method in the C. Lorenz-A.G. Ultra-Short Wave Guide Beam Process.

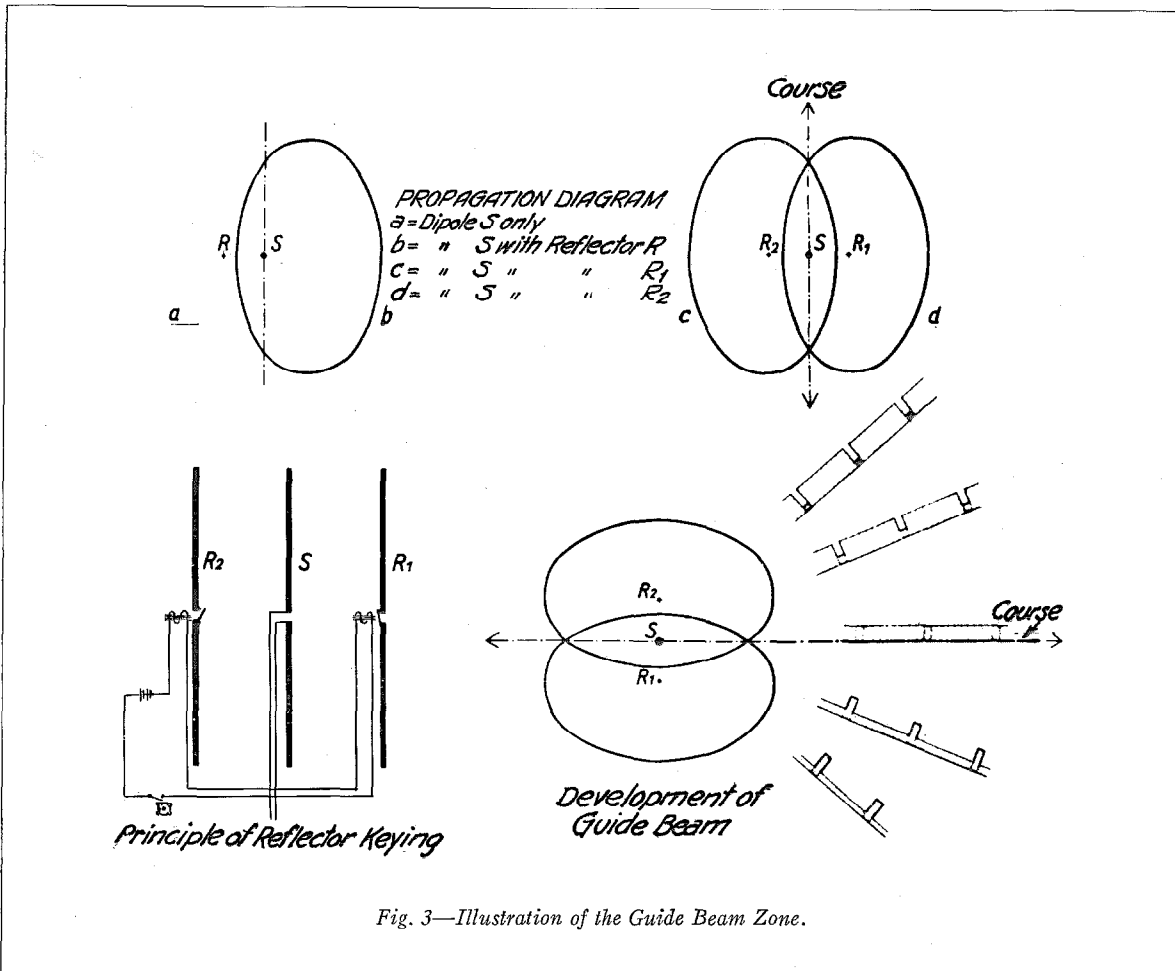

Fig. 3—Illustration of the Guide Beam Zone.

tion of complementary receiving equipment ("plane station") in the airplane. For the ground station, central and fully automatic remote control both of the main transmitter and of the marker transmitters is provided. On the control panel, indication of the correct working of all three beacons is provided by means of similar revertive signals. The airplane receiving set is fully automatic in operation; it employs a minimum number of valves, is simple in design, and is light in weight. The necessary range is ensured by an adequate design of the ground station.

The ground equipment comprises a 500 watt guide beam beacon transmitter together with two or four small (5 watt) transmitters for the transmission of the "signals," according to whether one or two directions of approach flight are provided for (Fig. 5). The remote control of all transmitters takes place from a central control set ("control station") where, also, the revertive signal impulses for the supervision of traffic are made perceptible. All the transmitters are crystal controlled, operating on ultra-short waves and are designed for all mains operation. They are supervised in every phase of operation by means of visual and audible indications at the "control station." These measures doubly ensure the operation of every component part and guarantee a high degree of reliability for the system as a whole. They represent an absolute necessity for purposes of landing when visibility is bad.

(a) *The Radio Main Beacon Transmitter.* The requirements for this transmitter emerge from the physical bases of the landing method employed in the C. Lorenz-A.G. system. In addition to necessary constancy of radiation to provide constant field strength, the navigational significance of "beacon" radiation requires a high frequency stability as well as an adequately constant degree of modulation. Fundamentally, the circuit employs a crystal controlled oscillator stage from which the operating frequency ($f_B = 33.3$ megacycles) is amplified in four stages and, by means of the grid potential, the fourth stage is tone modulated. The transmitter is shown in Fig. 6a, where the disposition of the constituent equipment may be seen. In the lower part are housed the component aggregates for the power supply which, in addition to the ventilation devices for the transmitter container, also

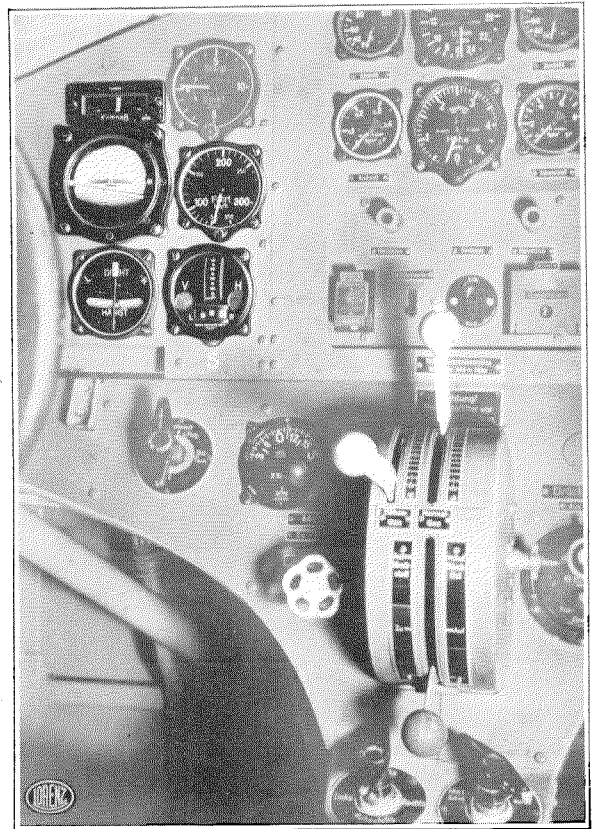

Fig. 4—Visual Indicator Equipment Mounted on the Dashboard of a Commercial Airplane in Conjunction with Other Navigational Instruments.

include the high and low tension rectifiers (selenium rectifiers and smoothing devices). Above this equipment are the component sections intended for the circuit distribution of the feed potentials including all the associated testing instruments and also the auxiliary devices used for modulation of the operating frequency and for the keying of the associated radiation system. Near the cast iron transmitter container, a quick acting voltage regulator operates from the local 3-phase mains regulated to $\pm 0.5\%$. The beacon transmitter is installed in a specially provided, small brick building from which feeder and keying lines connect to the radiator system. The latter consists of an energizing dipole, which is fed from the transmitter terminal stage, and on both sides of which a reflector dipole is placed at an interval of $\lambda/4$. These, with the energizing dipole, are in a plane vertical to the guide beam plane and are fed by radiation coupling. The complete vertical radiation system is mounted on

stiffened wooden masts erected directly in front of the beacon building (Fig. 6b).

(b) *The marker beacon (signal) transmitters* function on an operating frequency of $f_E = 38.0$ megacycles and differ, from a high frequency aspect, from the beacon transmitter only in the number of amplifier stages (Fig. 7). According to the purpose for which they are to be used, the modulation frequency is either 700 p : s (for the outer marker beacon signal) or 1,700 p : s (for the inner marker beacon signal); the allocated keying series are shown in Fig. 8. The current supply of the signal transmitters is arranged for mains connection, the anode and initial grid potential being obtained by means of dry rectifiers. The transmitter itself is of a rigid and concentrated design and includes complete mounted keying and revertive signal equipment as well as all the accessories.

With regard to all the transmitters, the following may be said: in principle, importance is attached to easy manipulation and control of the correct operation of all the component apparatus.

In addition to being remotely controlled all transmitters can be put into operation locally by means of switching devices which are conveniently accessible on the transmitter front panel. In practical operation they are normally connected and disconnected from the "control station" which is generally installed in the control tower of the airport.

(c) *Transmitter Radiation Fields.* The arrangement of the radiation fields, in relation one to another, is illustrated in Fig. 1. It shows how the approach path sector—produced as a result of the keying rhythm of the main transmitter by the alternating operation of the reflector dipole—is intersected at two characteristic points by the two radiation fields of the signal transmitter.

The transmission of the marker signals necessary to the landing process is effected by the upwardly directed, horizontal dipoles of the signal transmitters. The correct time period of reception (so-called wall strength) of the marker signals during flight is obtained by influencing in a simple way the radiation field of the horizontal

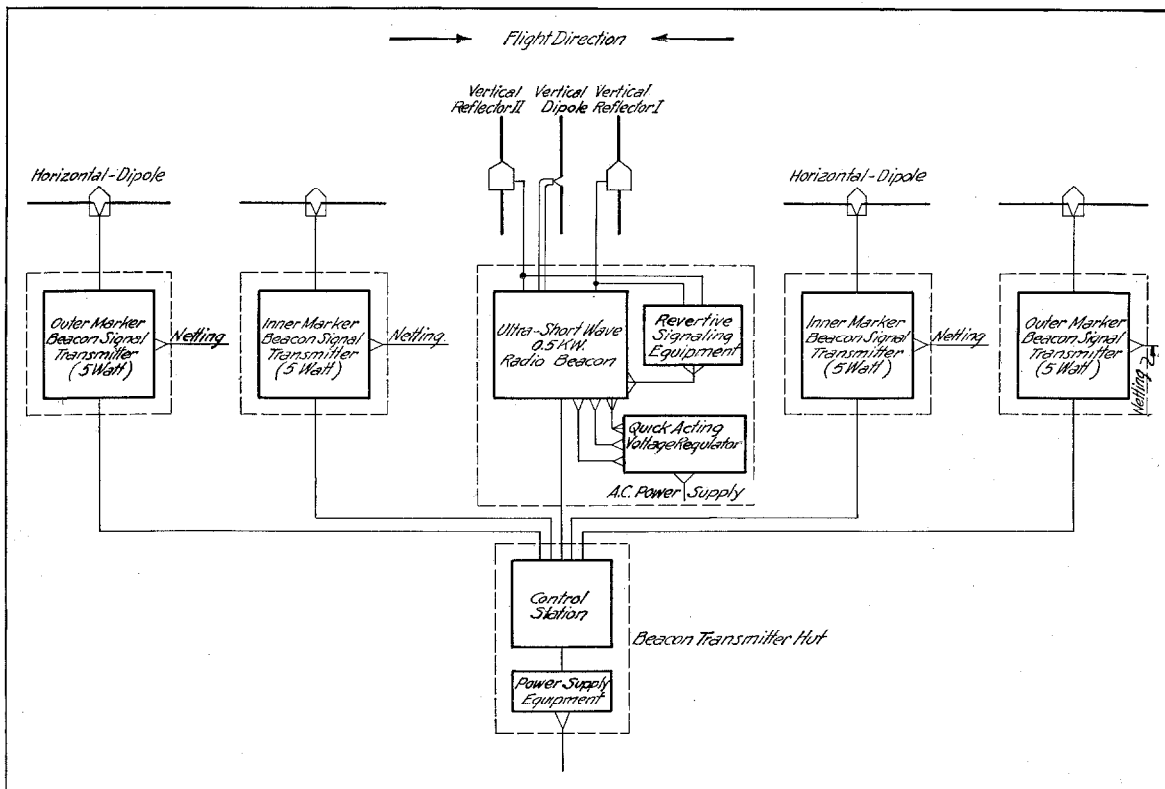

Fig. 5—Plan of a Complete Ultra-Short Wave Radio Beacon Landing System (C. Lorenz-A.G. System).

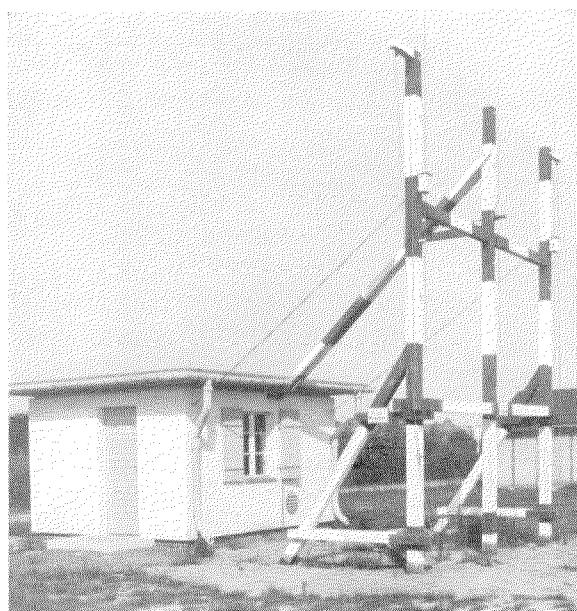
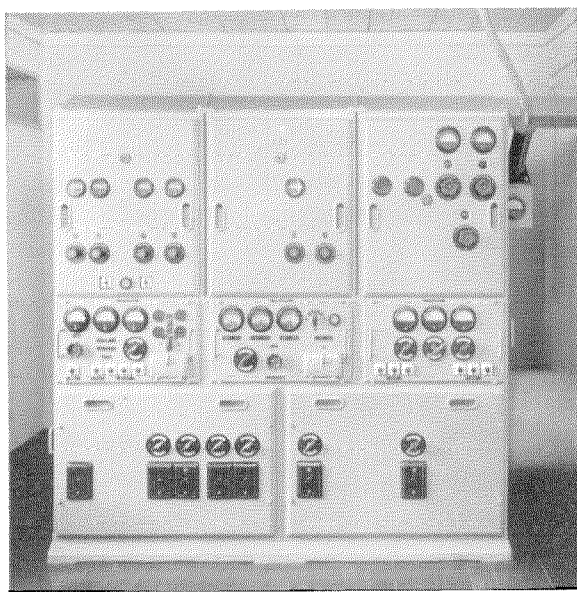

Fig. 6—Radio Beacon Guide Beam Transmitter. (a) The Beacon Transmitter Inside the Protecting Hut. (b) The Hut with Complete Radiation System.

dipoles. By a suitable arrangement of a wire netting, which may be regarded as a reflecting surface, it is possible with the dipole placed at about $\lambda/2$ above the surface to attain the required vertical radiation, the separation of the dipole from the reflection surface being considerably less at its center because of the curvature of the netting (Figs. 9a and 9b). Fig. 10 shows the

characteristic curve of this vertical radiation. The marker transmitter is housed in a wooden hut below the netting.

Operation of Ground Station. As already mentioned, the easy supervision at any time of the operation of all component parts is of exceptional importance in view of the purpose of the system. This is accomplished by means of visual and audible signals on the same apparatus from which the switching is done. The "control station" is accordingly the nucleus of the navigational system and, at the same time, the agency that regulates and supervises the manifold switching processes pertaining to traffic operations. The operating control of all transmitters is based on the revertive signal process: the mains voltage and demodulated antenna currents from all transmitters are carried back to, and suitably indicated at, the control station. The same operating supervision directly at the individual transmitters themselves is also provided.

In practice all transmitters are put in operation by means of one main switch on the remote control panel.

When planning the ground station the direction of approach to the airport for (perfect) landing is determined with due regard to the direction of the wind.

The main switch on the remote control panel with its corresponding control contacts indicated in color on the panel is so arranged that by switching either to one or the other side the appropriate marker beacons for that particular direction of approach are brought into operation. Simultaneously, by the same means, the keying of the beacon transmitter is adjusted in a manner such that dots are always transmitted to the port side of the course. These measures obviously add to the degree of safety in the carrying out of this navigation process.

On the front panel of the "control station" (Fig. 11) colored signal lamps show the presence of mains voltages and meters show that the transmitters are actually working the needles of these meters, swinging in the keying rhythm of each particular transmitter. Along with these purely visual signals, arrangements may be made for listening to the different keying signals and modulation frequencies by means of telephone control. Furthermore, any trouble is indicated acoustically by the operation of an alarm whistle

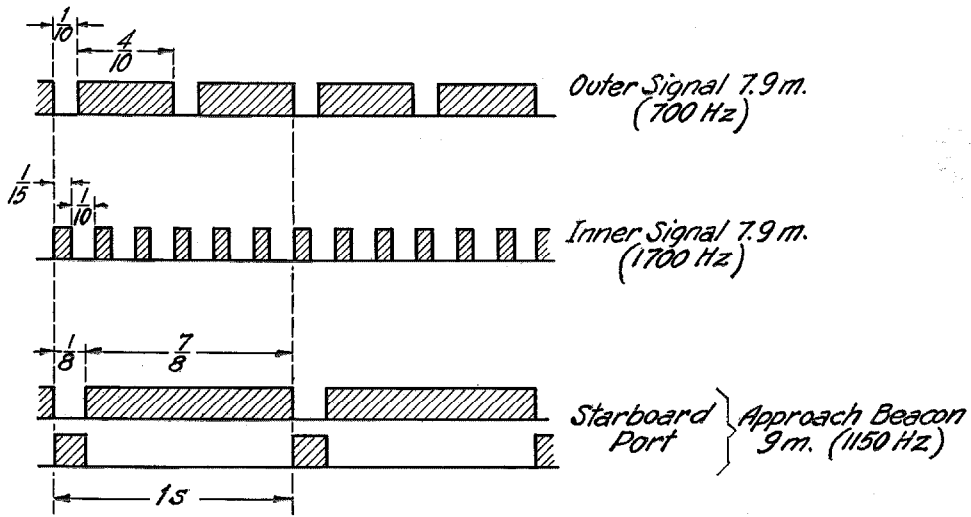

Fig. 7—Keying Sequence.

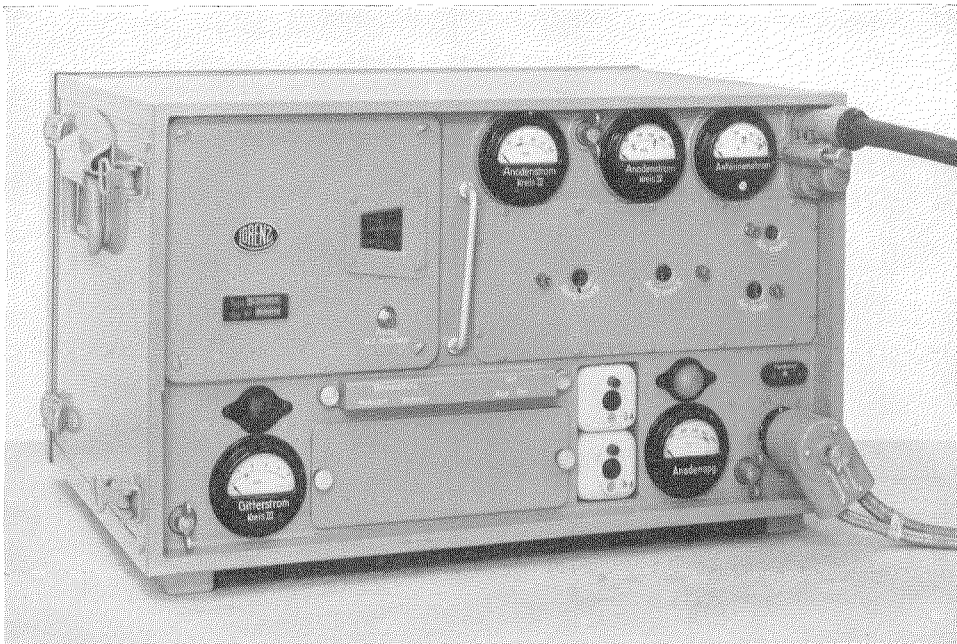

Fig. 8—"Signal Transmitter" with Mains and Antenna Cable Connected.

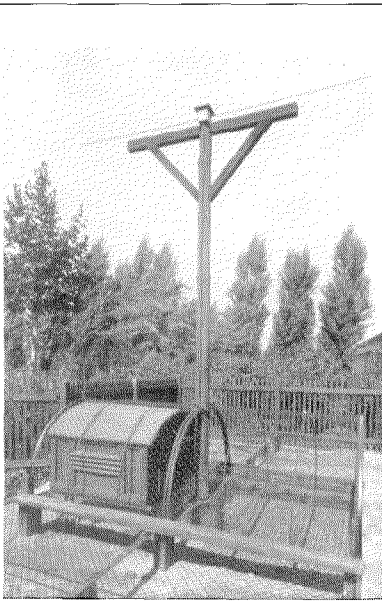

Fig. 9a—Complete Signal Transmitter System.

and visually by the warning signal of a drop indicator. In addition, simple means are provided for the quick testing of all control and revertive signal lines to all transmitters.

Revertive signal equipment which, in particular, is intended for checking the dipole relays and which is mounted near the transmission line, is an additional means of supervising locally the beacon transmitter.

The plan in Fig. 5 shows the fundamental design of the ground station in its electrical association with the central control and supervisory stations provided for two directions of flight and, correspondingly, four signal transmitters. The spacing of the complete ground system is dependent on the position of the airport and, above all, upon the immediately surrounding conditions. It is, therefore, determined as occasion arises.

The Airplane Receiving System (Airplane Set) for Landing Purposes. The airplane receiving system serves to receive the high frequency signals which follow one another successively on the

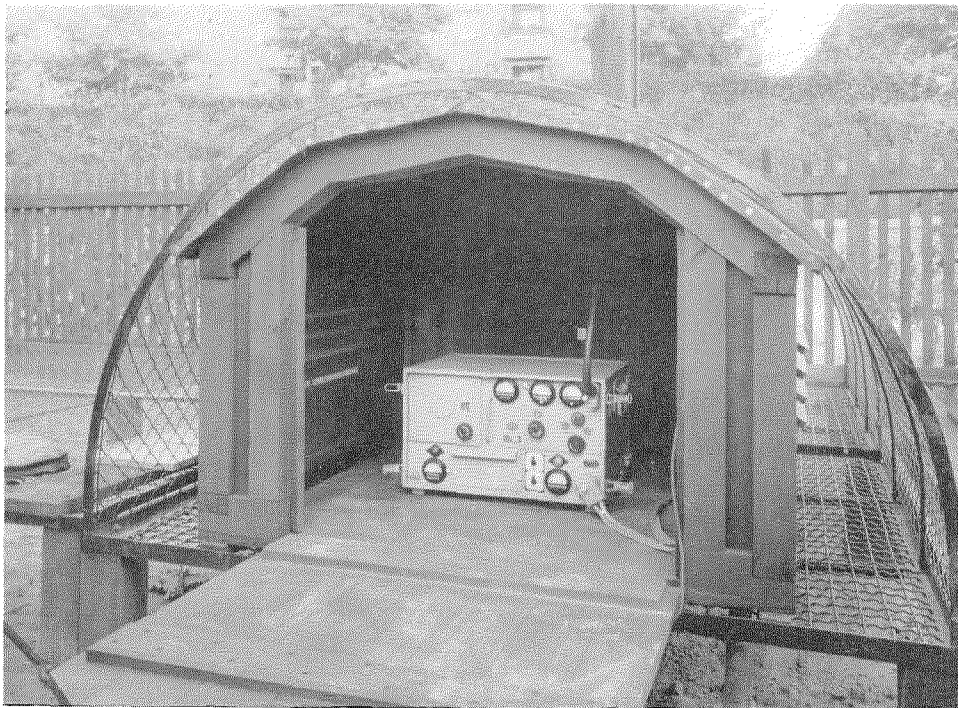

Fig. 9b—Signal Transmitter Erected in Wooden Hut under the Reflector Arch.

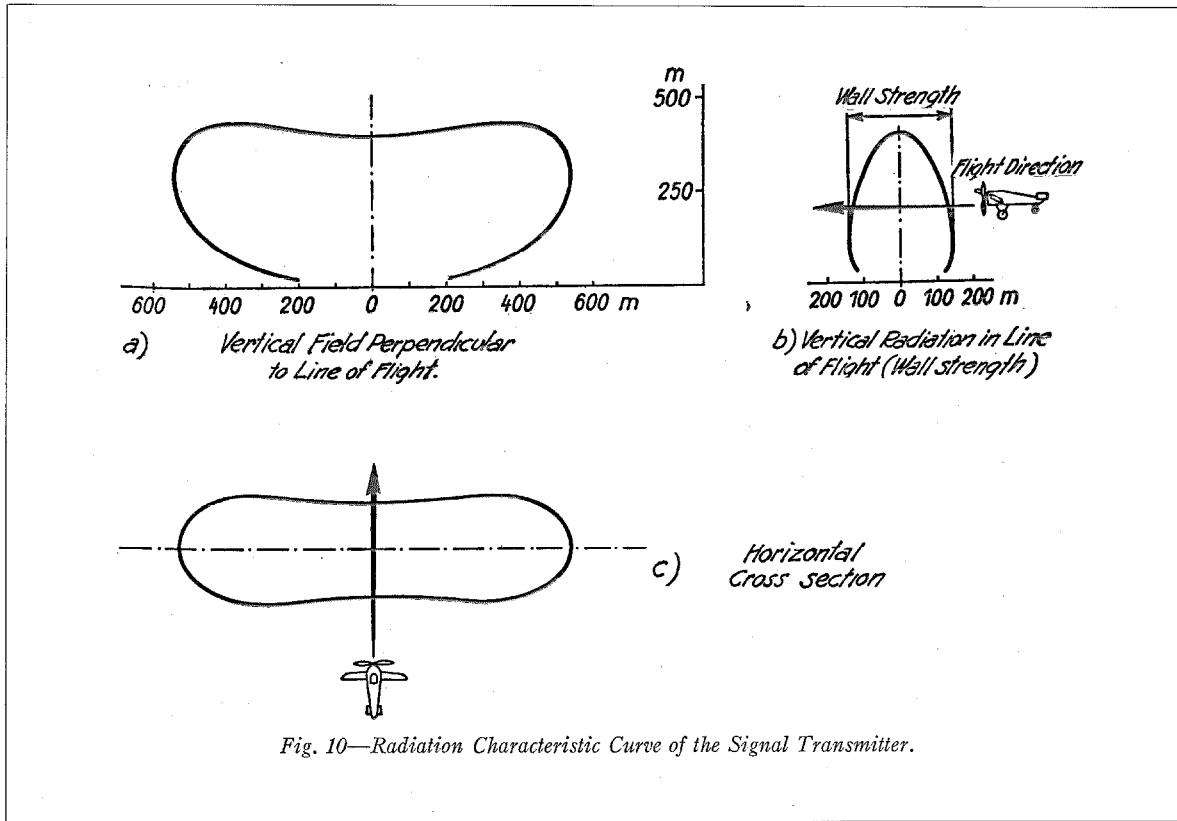

Fig. 10—Radiation Characteristic Curve of the Signal Transmitter.

principle of the landing method. It consists of the receiver and two associated receiving antennae. The apparatus for the pick-up of the beacon frequency is a simple amplifier which has a high frequency amplifier stage, a detector, and a low frequency amplifier. Automatic amplifier regulation maintains the sound volume fluctuations in the headphones (Fig. 12) within admissible limits even with very considerable field strength alterations during flight. A special detector, mounted in its own metal container, is provided for the reception of the marker beacon signals. It retransmits the demodulated tone frequencies of the outer marker beacon signals to the low frequency amplifier of the beacon receiver. Here, therefore, all three modulation notes of the ground transmitter are amplified. A filter network (frequency filter), adjusted to the existing tone frequency, filters the modulation frequencies of the marker signal transmitter (700 p : s or 1,700 p : s, respectively) and passes these low frequency voltages on to the visual indicator apparatus. During the approach to the radio

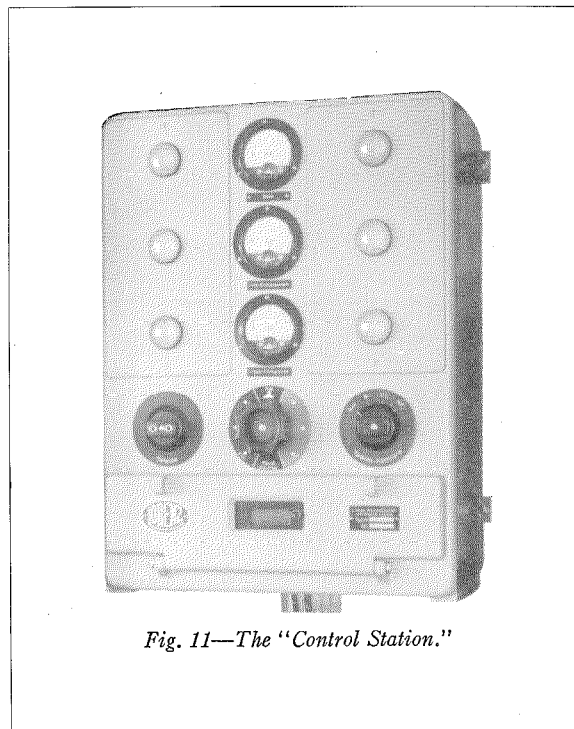

Fig. 11—The "Control Station."

beacon, an approximate idea of its distance is obtained by means of a vertical indicator instrument which is in the visual indicator set and which is connected through a rectifier to the low frequency amplifier. The modulation frequency of the main beacon (1,150 p : s) governs the amplifier regulation as well as the indication of distance and divergence to the side. Special equipment, which is connected to the low frequency amplifier through a rectifying arrangement, and which is mounted horizontally in the instrument container of the visual indicator set, indicates divergences to the side and serves to clearly determine the course of the airplane. During flight, a switch mounted in the operating set on the dashboard of the airplane is placed in the "approach" position, and amplifier regulation is effected. (For the purpose of glide path landing—vertical navigation—this switch is thrown to "glide path" at the outer marker beacon signal, whereupon automatic amplitude regulation is disconnected.) The airplane battery provides the power supply for the receiving set and operates the converter; the latter supplies power for the filament lamps as well as the necessary voltage for the anode circuit of the amplifier. An example of a typical installation of an airplane set in an airplane of the "Deutschen Luft-Hansa" is shown in Fig. 13.

A vertical dipole about 90 cm. in length, connected through a suitable transformer to the receiver input, serves as an antenna for the 9 meter wave of the beacon transmitter (Fig. 14). A horizontal dipole consisting of two copper tubes about 1 meter in length is used for the reception of the marker signals. These copper tubes are fastened at an interval of about 5 cm. along the airplane and under the fuselage by means of streamlined supports, and are connected through a transformer to the detector. The complete airplane receiving equipment, accordingly, consists of the beacon receiver, which contains the common low frequency amplifier, the detector, and the frequency filter, as well as the battery box or a rotary converter. On the dashboard of the airplane is mounted the visual indicator set which includes the two instruments indicating the distance and the deviation from the course as well as the two signal lamps.

Ultra-Short Wave Landing Radio Beacons in the European Air Communications System

If it be recognized that adaptation of the requisite ultra-short waves to this landing procedure makes normal aircraft radio communication on medium waves for additional direction find-

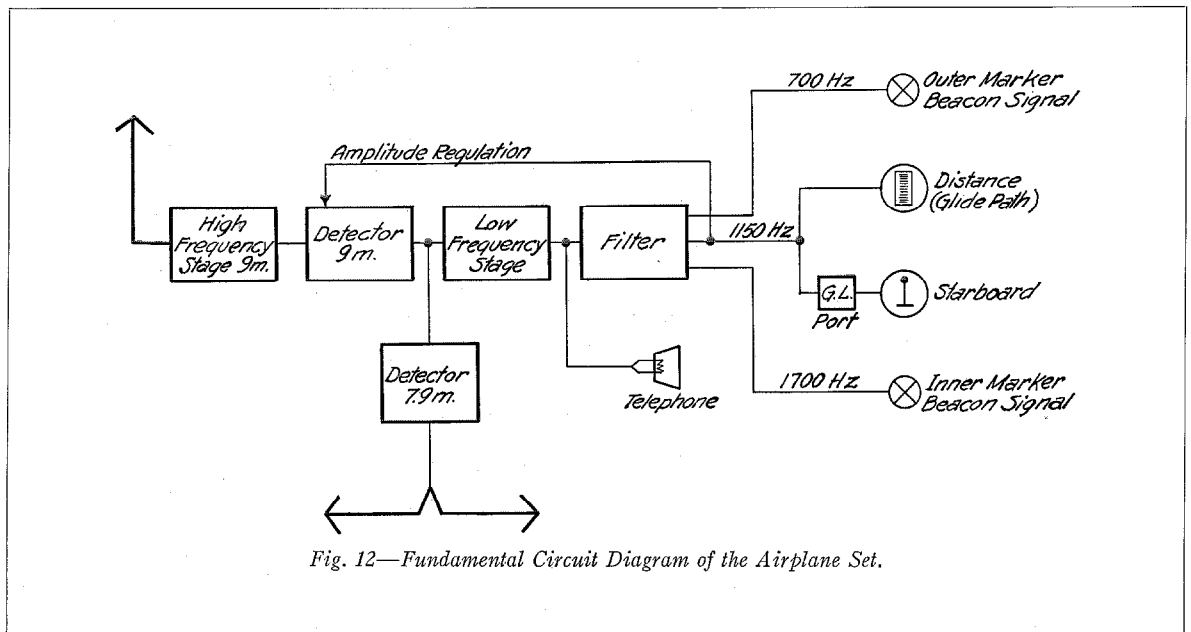

Fig. 12—Fundamental Circuit Diagram of the Airplane Set.

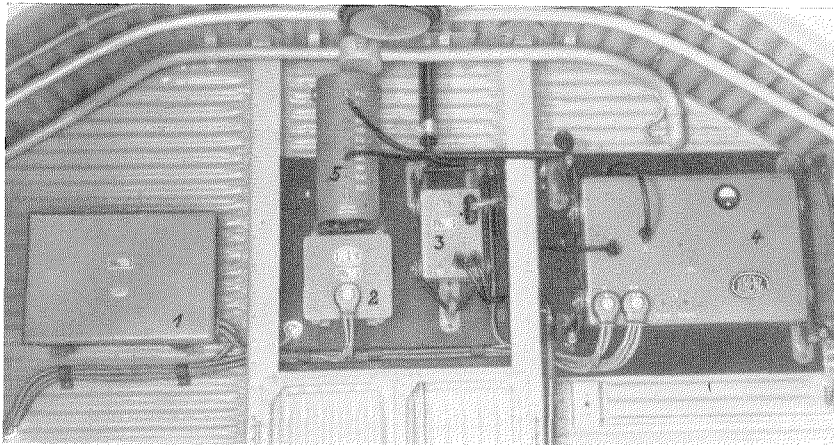

Fig. 13—Installation of a Receiving Set in Goods Carrying Airplanes Belonging to the Deutschen Lufthansa.

ing indication unnecessary and, also, that the normal airplane radio equipment is available for communication purposes during the last minutes prior to landing, a very essential advantage will have been achieved from the viewpoint of the service organization; this, quite apart from the fact that navigation on ultra-short waves is, in practice, not interfered with by simultaneous transmission and reception on medium waves. Furthermore, the ground equipment necessary for this landing method is designed so that it can, without difficulty, be introduced into existing ground station radio organizations. As early as the year 1932, under the direction of German Air Authorities, an experimental system was erected by C. Lorenz-A.G. for bad weather landing at the Berlin-Tempelhof airport and was demonstrated to those attending the International Air Service Conference in January, 1933. The next conference (Geneva, 1934), also the Meeting of Experts (Paris, November, 1933, and Warsaw, September, 1934), dealt with the improved design of this system and determined the operating frequency for the guide beam beacon as well as for the marker beacons,

together with the associated modulation frequencies. These decisions and further practical experience led, during the last two years, to a rapid extension of the landing radio network in Germany and, from time to time, other European countries have adopted it. Today, the following German state airports are equipped with radio landing systems: Berlin, Breslau, Danzig, Leipzig, Frankfurt a/M., Hamburg, Hannover, Köln, Königsberg, München, Nürnberg, Stettin, and Stuttgart. Amongst foreign airports, the following already have complete sets: London (three radio landing systems), Milan, Paris, Stockholm, Warsaw, Vienna, and Zürich; similarly, Japan and Russia.

These radio landing systems are in preparation for Budapest, Prague, Rome, Venice, as also for Poland, Australia, South Africa, and South America.

In view of the great significance of the air service in modern communications, the landing radio beacon offers security facilities which can no longer be disregarded. It is, in fact, fundamental to developments in the important branch of aeronautics pertaining to safety.

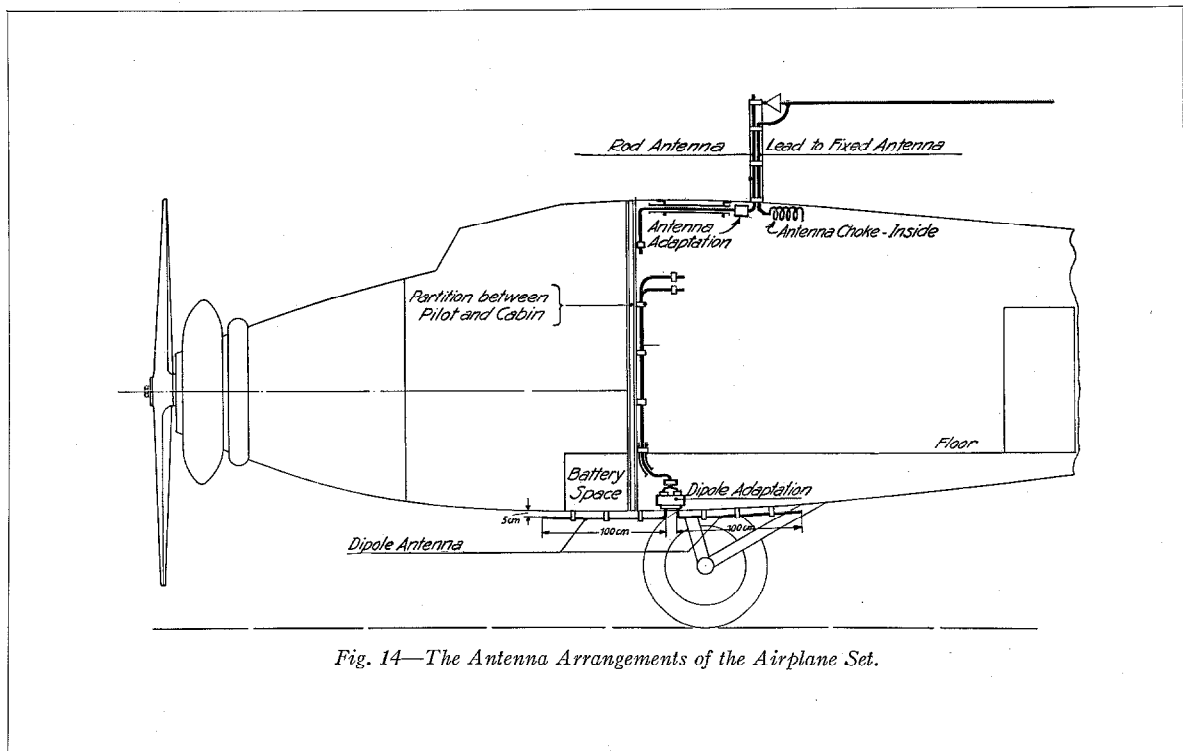

Fig. 14—The Antenna Arrangements of the Airplane Set.

Bibliography

The following list of publications covers specific features and throws light on the development of this navigation system:

1. O. Scheller: "Flugzeugsteuerung bei unsichtigem Wetter," (Airplane control during bad visibility), *Elektrotechnische Zeitschrift*, 1929, No. 6, page 191.
2. E. Kramar: "Neuere Arbeiten auf dem Funkbakengebiete," (Recent developments in the radio beacon field), *Zeitschrift für Hochfrequenztechnik und Elektroakustik*, 1932, Vol. 39, page 88, (No. 3.)
3. Gloeckner: "Verfahren zur Erleichterung von Blindlandung," (Process to facilitate blind landing), *Zeitschrift für Flugtechnik und Motorluftschiffahrt*, 23, Year 1932, page 347.
4. E. Kramar: "Die Ultrakurzwellen-Funkbake," (The ultra-short wave radio beacon), *Elektrische Nachrichtentechnik*, 1932, No. 12, page 469.
5. E. Kramar: "Ein Beitrag zur Gleitwegblindlandung von Flugzeugen," (A contribution to the glide path blind landing of airplanes), *Elektrische Nachrichtentechnik*, 1933, No. 11, page 451.
6. E. Kramar: "A new Field of Application for Ultra-Short Waves," *Proceeding of the Institute of Radio Engineers*, Vol. 21, No. 11, November, 1933, page 1519.
7. Jung-Zaepfer and E. Kramar: "Ein neuer Weg für Gleitwegbaken," (A new method for glide path beacons), *Luftwissen*, 1934, No. 4, page 92.
8. E. Kramar: "Ein Impulsanzeige-Verfahren für Funkbaken," (Impulse indicator process for radio beacons), *Elektrische Nachrichtentechnik*, 1934, No. 4, page 152.
9. P. v. Handel: "Die Blindlandung mit Hilfe elektrischer Verfahren," (Blind landing with the assistance of electrical process), *Luftwissen*, 1935, No. 7.
10. E. Kramar: "The Present State in the Art of Blind-Landing of Airplanes using Ultra-Short-Waves in Europe," *Proc. I. R. E.*, Vol. 23, No. 10, October, 1935, page 1171.
11. R. Elsner and E. Kramar: "Blindlandung von Luftfahrzeugen mittels Gleitwegbaken," (Blind landing of airplanes by means of glide path beacons), *Luftwissen*, 1935, No. 11.

Installation of Radio Distribution in the Beaujon Hospital, Paris

By G. MEUNIER

Le Matériel Téléphonique, Paris, France

THE Beaujon Hospital, erected at Clichy in 1934, with its twelve stories surmounted by its water reservoir, constitutes one of the highest buildings authorised to be built in the Paris area. It is also the most modern hospital. Perfectly ventilated, it faces south with a frontage of over 100 meters, and comprises on each floor four large common wards, disposed in rack-tooth style, where the private wards, resting, dressing, and operating chambers are located, as well as all other associated accessories of this immense "hospital-factory."

More than 1,000 beds are available. On each floor, terraces prolong each ward, thus enabling patients to remain for long periods in the sun and open air under the best possible hygienic conditions. The last two stories, more especially reserved for the treatment of consumptives, are entirely disposed in terraces to which access is obtained from the common and individual wards through large windows.

Annexes are located at the rear of the main building. They are equipped in an up-to-date manner for supplying power, light, and heat to all the buildings.

The dressing and operating rooms for special treatments (radiography and radiotherapy) are provided with the most modern equipment.

The engineers of the "Poor Law Administration," who collaborated in creating this beautiful building, considered that above all, it had to be pleasant and agreeable both to patients and visitors. They endeavoured to eliminate all signs of sadness and did their utmost to achieve an atmosphere of cheerfulness. Air and light are abundant, and the view of Paris from the terraces is magnificent. The decorations of the wards, all different, are bright and pleasing.

It was appreciated that, unfortunately, highly pleasant surroundings will not prevent patients from becoming bored, and radio was resorted to as the best means of diversion. Several hospitals in France had already been equipped with radio, the initiative in furthering these installations

having been due more to social groups than to the hospital managements. For a considerable time, patients themselves have had radio sets installed in nursing homes or sanatoriums. While sometimes quite rudimentary, these, nevertheless, afford the patient and his companions considerable pleasure.

Prior to the Beaujon Hospital installation, Le Matériel Téléphonique had carried out two installations in similar institutions: one for 50 head receivers at the Compiègne Hospital and another for 300 at the Colmar Hospital. The Beaujon Hospital project was of much greater magnitude, since 900 beds were to be provided with radio and 40 rest wards with loudspeakers having adjustable volume.

The decision to instal radio distribution in the Beaujon Hospital was made at a time when the erection of the building was well advanced; and, prior to approaching the firms capable of carrying out such an installation, an order had been placed with the general contractor for the installation of the radio distribution lines. These lines were composed of single-pair 0.65 mm. lead-covered telephone cable; therefore, their capacity was not adequate for distributing several programmes simultaneously or for operating the forty loudspeakers in the rest rooms with sufficient volume.

In view of the foregoing, it was decided to adopt distribution at low power, i.e., at a level allowing only for direct listening with head receivers. Loudspeakers connected in place of head receivers were provided with an amplifier fed directly from the power supply.

The distribution center was required to provide rediffusion of:

- (1) Record music by means of two pick-ups,
- (2) Musical retransmissions brought in directly by the P.T.T. from the different Paris theatres over telephone lines.
- (3) Orchestral music or songs produced in a studio specially provided for this purpose in the hospital itself,
- (4) Announcements and news items transmitted at the distributing apparatus itself.



Beaujon Hospital, Paris.

Equipment for meeting these different purposes was designed as follows:

The radio receiver consists of a Type 63, Le Matériel Téléphonique radio set, and is located on the second floor of the building. An anti-parasite lead-in, a filtrostat system, and a single wire antenna are used.

This set can operate, either the power amplifiers or the control loudspeaker placed in the cabinet, thus permitting the selection of a station while another programme is being furnished to the patients.

The pick-up, Type 104-A, in an oil bath, the announcer's microphone of the diaphragm type, the studio microphone of the electrodynamic type, and the line from the theatrophone terminate in a special preamplifier.

The radio receiving set or the special preamplifier is connected to two No. 1212 amplifiers, each with two 2-A.3 tubes in push-pull, and capable of giving a modulated power of approximately 10 watts per amplifier.

A second group of two amplifiers, Type 1212, has been foreseen, as a spare group to replace the

former, or for joint working in the event of an extension of the installation.

All the operations enabling the transmission of one of the five types of programmes contemplated are made by means of relays. A key and a lamp signal in the middle of the center panel of the cabinet correspond to each of these retransmissions.

To effect the retransmission of a given programme, it is only necessary to throw the corresponding key, with the result that the preceding programme is cut off and the connection between the power amplifiers and the distribution lines is momentarily interrupted, thus allowing the operator to adjust the retransmission without causing inconvenience to the patients. Upon restoring the key to its normal position, the connection between the amplifiers and the distribution lines is secured again.

Another key allows for the suppression of the other key positions without any programme being switched on. Finally, the announcer's microphone is operated by a special key: by operating

it in one direction, the programme transmitted is suppressed and the announcer's microphone is connected; by operating it in the opposite direction, the preceding programme is again switched on.

The control loudspeaker can be used either on the distribution, i.e., after the amplifiers, or only on the radio receiving set for selecting a station. This loudspeaker, naturally, remains in circuit when changing the programme, the connection between the power amplifiers and the distribution lines being suppressed. On the other hand, the loudspeaker is automatically cut off when the key connecting the announcer's microphone is operated.

The control equipment utilises about ten relays of the automatic telephone type and is fed from alternating current (110 volts, 50 cycles) through a selenium rectifier. A lamp signal installed near the auditorium microphone indicates whether the latter is connected. Finally, a switch placed near this microphone enables the artists to cut off the transmission when their performance is finished.

The control loudspeaker is paralleled by an

output power level indicator and can thus be cut out without losing the distribution control.

The whole equipment, mounted in a metal cabinet, has the operating and control apparatus described above placed on its face and includes two pick-ups on a desk-shaped shelf. The lower front portion contains a record filing cabinet; the lower rear houses the power amplifiers.

In planning the installation, much attention was paid to the detection of trouble on lines or distributing apparatus (head receivers and loudspeakers). It was almost impossible to equip the distribution circuits with fuses sensitive enough to cut out defective lines or apparatus automatically, particularly in the case of a partial short circuit or insulation defect. Hence the installation was divided into a certain number of sections, in principle one section per floor, each with an individual line to the operating cabinet.

Every line is controlled by a two-position key, permitting connection to the power amplifiers through a fuse or the cutting out of amplifiers, or else the closure of a circuit to an ohmmeter in the operating cabinet.

When a fuse is blown, indication is given to the



Head Receivers in Use.

operator by the lighting of a lamp corresponding to the defective circuit. It is then easy for him to throw the corresponding key so as to connect the line to the ohmmeter and thus determine whether the trouble is permanent or momentary. The electrician in charge of maintenance makes a careful test of the line by insulating successively at the cut-out boxes the different sections of the line, and thus rapidly locates the trouble.

If the trouble is not such as to blow the fuse but is interfering with the retransmission as a whole, it is easy, by connecting the lines one after the other to the ohmmeter, to locate the defective circuit, to momentarily insulate it, and to make a quick check without disturbing the rest of the installation.

Head receivers, meeting special requirements, were provided. They are very light in weight and do not press on the patients' heads; they are practically unbreakable and capable of being frequently disinfected in formaldehyde fumes. A volume control is readily accessible to the patient. Further, it was desirable that receivers might be detachable from the head band so that patients might hold them by hand. The existing L.M.T. model was modified to meet these requirements.

The ear pieces, in black moulded material, were replaced by white ones of a material similar to Polopaze. The volume control is of special design. It is housed in a white box of a material similar to the receivers and is connected to the middle part of the cord so that the patient may reach it quite easily.

A special cord was developed to resist formaldehyde fumes. It is equipped with a telephone type plug. The corresponding jack is contained in a metallic junction box which is white enamelled and is mounted on the wall for connection to the lead-covered cable.

A resistance shunts the line when the head receiver is removed, in order to avoid changes in volume with variation in load.

The loudspeakers installed in the rest rooms employ a 22 cm. diaphragm similar to that used in radio receiving sets and an amplifier with two stage triodes giving a power of approximately 1.5 watts.

In place of an input transformer, the grid is connected directly to the distribution line through a set of resistances and a potentiometer. The

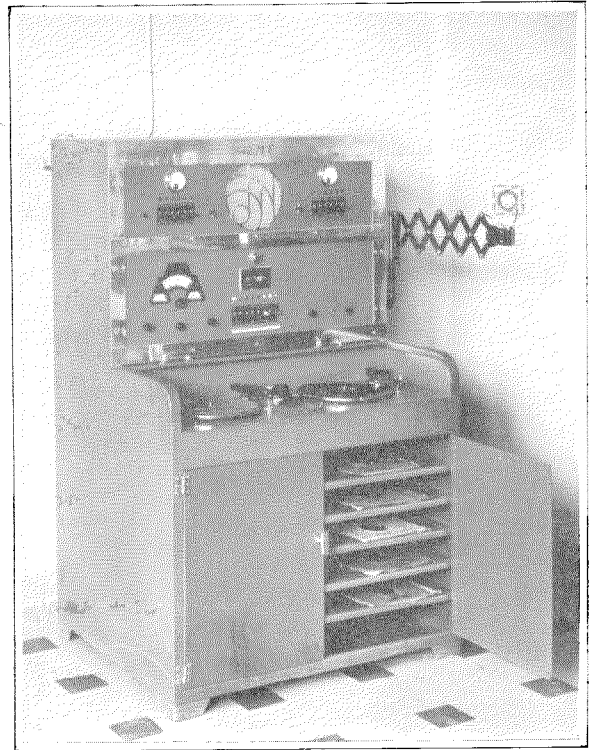

Programme Distribution Switchboard.

pilot lamp shows whether or not the apparatus is energised.

A tone control provides an especially suitable frequency curve. This was deemed necessary inasmuch as the rooms in which the loudspeakers are installed have highly unfavorable acoustic properties.

The Beaujon Hospital installation has the following characteristics:

Distribution at 4 to 5 volts approximately,
 Power of the distributing center: 20 to 40 watts,
 The simultaneous feeding of 500 to 900 head receivers and of 40 loudspeakers of 1.5 watts by means of amplifiers.

The distributing center is located in the library of the hospital. It is operated by the librarian, since the design is such that no special technical knowledge is required for operating the equipment.

This installation constitutes a standard for radio distribution in French hospitals. Several other institutions—sanatoriums, nursing homes, schools, etc.—are now contemplating the installation of a similar system.

Propagation Tests with Micro-Rays

By A. G. CLAVIER

Les Laboratoires Le Matériel Téléphonique, Paris, France

THIS paper relates to tests on propagation of micro-rays, which were carried out between experimental stations at St. Margaret's Bay (England) and Escalles (France) during the latter part of July and the beginning of August, 1935.

It had been known for some time that, on the frequency of 1,700 megacycles per second, which had been in use between the micro-ray stations at Lympne and St. Ingelvert aerodromes, variations of signal strength were actually occurring, particularly during the hot days of the year. The tests here considered were undertaken in order to ascertain what influence a change of wavelength would produce on the amplitude and frequency of these fading phenomena.

The type of valves which was used did not differ from that in operation on the Lympne-

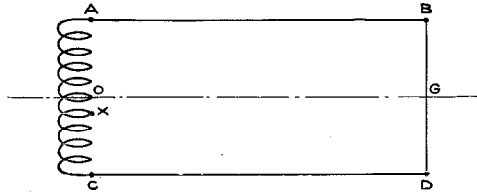

Fig. 1—Schematic Oscillating Circuit of a Micro-Ray Valve. AOC is the Oscillating Electrode and ABGDC, the External Circuit.

St. Ingelvert micro-ray link. Descriptions of these micro-ray valves have already been given.^{1, 2, 3}

¹ "Production and Utilisation of Micro-Rays," by A. G. Clavier, *Electrical Communication*, July, 1933.

² "The Anglo-French Micro-Ray Link between Lympne and St. Ingelvert," by A. G. Clavier and L. C. Gallant, *Electrical Communication*, January, 1934.

³ "Micro-Ray Communication," by W. L. McPherson and E. H. Ullrich, *Journal of the Institution of Electrical Engineers*, 1936, Vol. 78, No. 474.

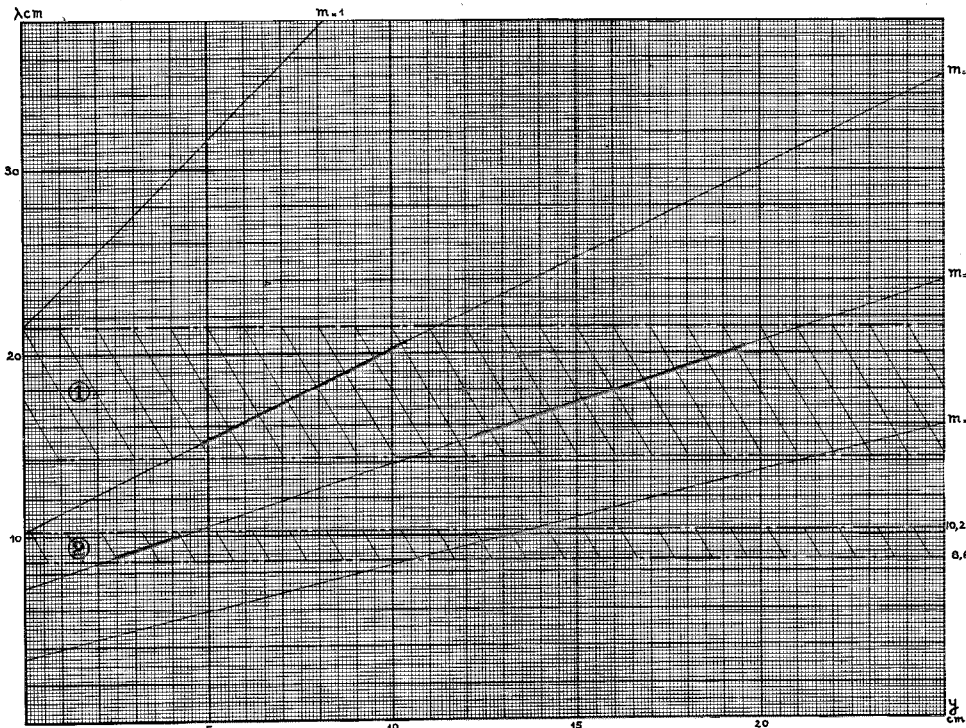

Fig. 2—Chart Showing Ranges of Wavelengths Produced by a Micro-Ray Valve (Type K). y is the Length of Transmission Line Leading to the Doublet and λ , the Wavelength in cm.

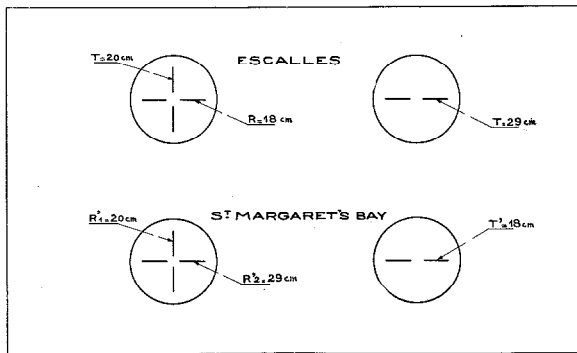

Fig. 3—Arrangement of Antennae for Propagation Tests.

They are made of three electrodes having a cylindrical symmetry, the tungsten filament being the axis of the structure, and a helicoidal oscillating electrode being provided with two wires connecting its extremities to the load circuit. The external electrode is a molybdenum cylinder, the axis of which coincides with the filament.

Since some of the components of micro-ray equipment are closely related to the frequency

employed, it was decided to carry out the tests on a few frequencies of suitable separation. Valves and other components were then designed for these frequencies.

The main factor underlying the design of a micro-ray valve for a specified frequency range has been found to be the length of the wire of the oscillating electrode.⁴ This can be shown by the following considerations.

The mechanism of electron movements inside the valve results in the production of a negative leakance along the wire of the oscillating electrode when suitable voltages are impressed on the electrodes. Thus, if we represent the oscillating circuit as in Fig. 1, it is made of two parts, one, *AOC*, being the oscillating electrode itself and the other, *ABGDC*, the external circuit. When stationary conditions are obtained, it can be assumed that *O* and *G* are nodal points for the oscillating voltage. Then call *V* the difference in

⁴ United States Patent 1,959,019, March 7, 1932.

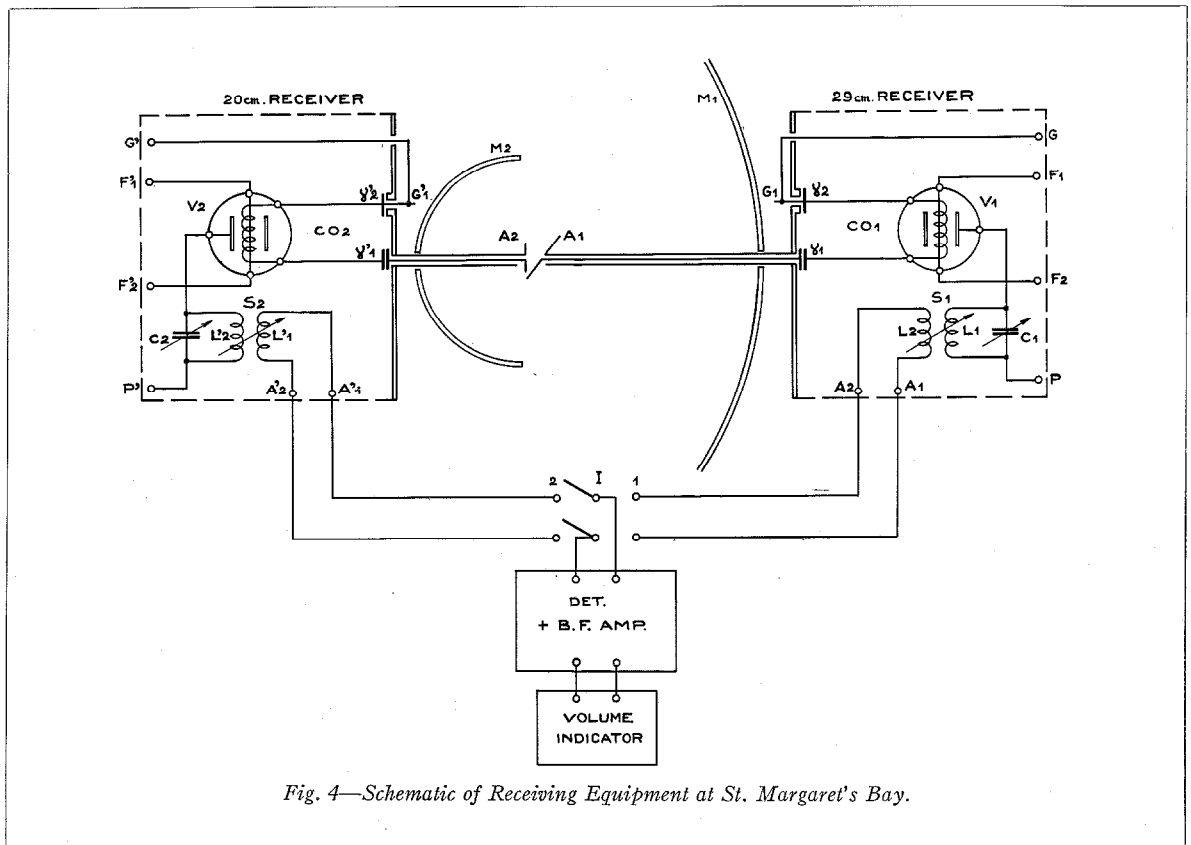

Fig. 4—Schematic of Receiving Equipment at St. Margaret's Bay.

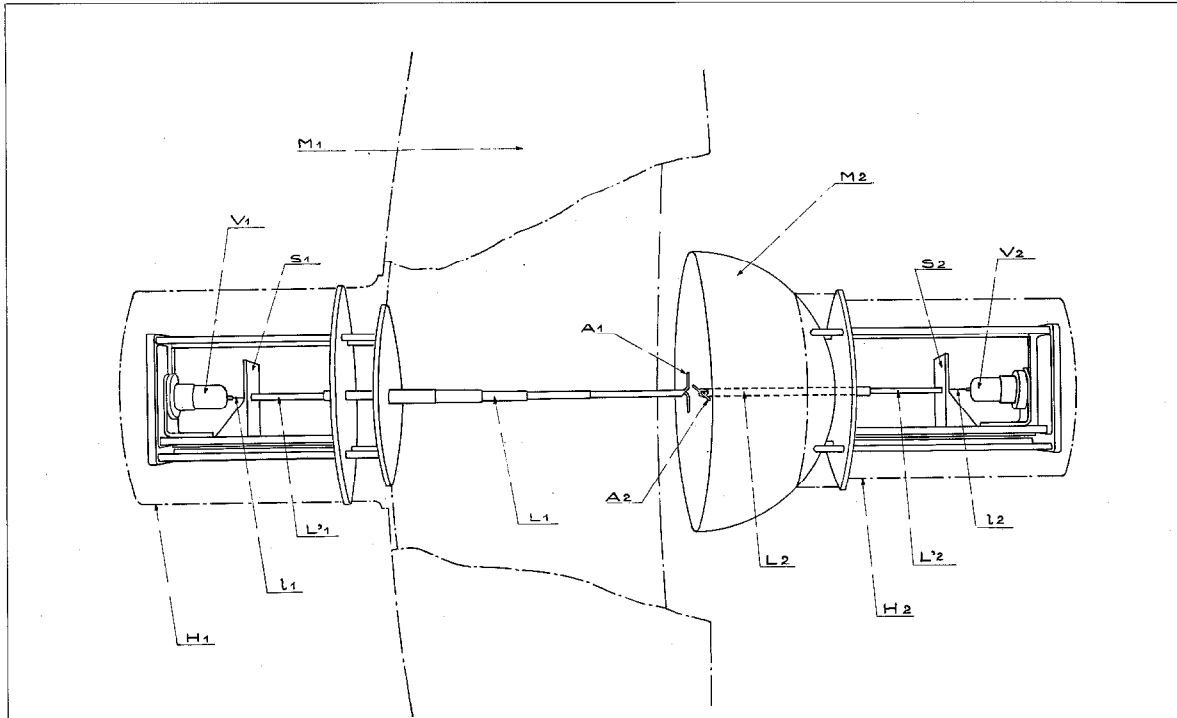

Fig. 5—Mounting of Two Receiving Valves on One Electro-Optical System at St. Margaret's Bay.
 L_1 Transmission Line Leading from Antenna A_1 to Receiving Valve V_1 Behind the Paraboloidal Reflector M_1 .
 L_2 Transmission Line Leading from Antenna A_2 to Receiving Valve V_2 Behind the Hemispherical Reflector M_2 .
 H_1, H_2 Metal Coverings for Receiving Valve Assembly.

volts between any point X of the oscillating electrode and point O . Let i be the high-frequency current and r, l, g, c the usual resistance, inductance, leakance, and conductance coefficients per unit length. The voltage and current relationships may be expressed as follows:

$$-\frac{\partial V}{\partial x} = ri + l \frac{\partial i}{\partial t},$$

$$-\frac{\partial i}{\partial x} = gV + c \frac{\partial V}{\partial t}.$$

From these equations the following general expression may be derived:

$$\frac{\partial^2 V}{\partial x^2} = \left(l \frac{\partial}{\partial t} + r \right) \left(c \frac{\partial}{\partial t} + g \right) V.$$

A solution of the form

$$V = V_0 e^{j(\omega t - \beta x)}, \quad \text{where } j = \sqrt{-1},$$

is obtained when

$$lg + cr = 0,$$

$$g = -\frac{cr}{l}$$

and

$$\beta^2 = \omega^2 cl \left(1 + \frac{r^2}{l^2 \omega^2} \right) \approx \omega^2 cl.$$

Taking β as the positive square root, the solution takes the following form:

$$V = V_1 e^{j(\omega t - \beta x)} + V_2 e^{j(\omega t + \beta x)}.$$

Assuming that point O is a nodal point for the voltages $V_1 = -V_2$,

$$V = -2jV_1 \sin \beta x \times e^{j\omega t}.$$

It is then found that

$$i = j \frac{2\beta V_1}{r + j\omega l} \cos \beta x \times e^{j\omega t}.$$

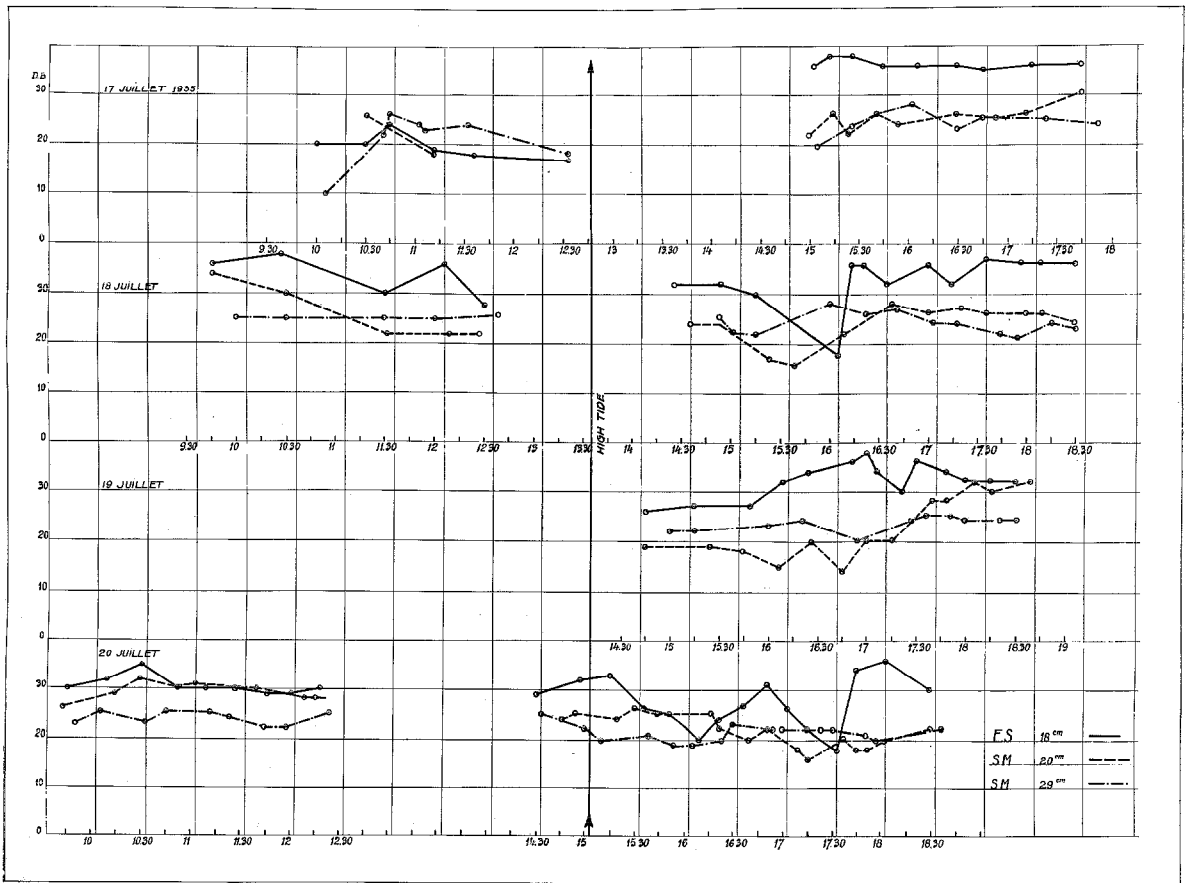

Fig. 6—Propagation Tests Between St. Margaret's Bay, England, and Escalles, France, Showing Signal Strength Above Noise Level.

Between two points X and X' , symmetrical with respect to O , the voltage amplitude will be $-4jV_1 \sin \beta x$. It follows that the internal impedance between the extremities A and C of the electrode will be

$$Z_i = -\frac{2r}{\beta} \operatorname{tg} \beta \frac{\Lambda}{2} - 2j \sqrt{\frac{l}{c}} \operatorname{tg} \beta \frac{\Lambda}{2}$$

when Λ is used to designate the length of the wire of the oscillating electrode.

Now the external circuit can be considered as a transmission line AB, CD with a load R at the end due to radiating resistance.

Let

$$AB = CD = y;$$

then, if Z is the surge impedance of the transmission line, the input impedance is

$$Z_e = Z \frac{R \cos \beta'y - jZ \sin \beta'y}{Z \cos \beta'y - jR \sin \beta'y}$$

We shall consider β' as approximately equal to β , which means that the propagation of the waves along the oscillating electrode and the transmission line will be assumed to be identical. Moreover, R will be assumed as relatively small compared with Z . For instance, in the case of two wires AB and CD 18 mm. apart, with a diameter of 2 mm., Z is approximately equal to 345 ohms and R to 8 ohms. In this case Z_e becomes approximately equal to

$$Z_e \approx \frac{R}{\cos^2 \beta y} - jZ \operatorname{tg} \beta y.$$

The conditions for sustained oscillations may then be written

$$\begin{aligned} -\frac{2r}{\beta} \operatorname{tg} \beta \frac{\Lambda}{2} + \frac{R}{\cos^2 \beta y} &= 0, \\ 2\sqrt{\frac{l}{c}} \operatorname{tg} \beta \frac{\Lambda}{2} + \sqrt{\frac{l'}{c'}} \operatorname{tg} \beta y &= 0. \end{aligned}$$

Considering only the simplified case when

$$\sqrt{\frac{l'}{c'}} = 2\sqrt{\frac{l}{c}}$$

i.e., assuming there is no discontinuity in characteristic impedance on either side of AC, the condition which determines the wavelength is then

$$\lambda = \frac{\Lambda + 2y}{m}$$

where m is any integer.

The condition for sustained oscillation is then

$$-\frac{r}{\beta} \sin \beta \Lambda + R = 0.$$

This implies that $\sin \beta \Lambda > 0$ and determines the ranges of possible wavelengths

$$\begin{aligned} \lambda &> 2\Lambda, \\ \Lambda &> \lambda > \frac{2}{3}\Lambda, \\ \frac{\Lambda}{2} &> \lambda > \frac{2}{5}\Lambda. \end{aligned}$$

But the output delivered to the doublet BD is not constant throughout each possible range. This output can be calculated as a function of the circuit elements and is found to be

$$P = \frac{4V_1^2}{R} \frac{\sin^2 2\beta y}{1 + \frac{Z^2}{4R^2} \sin^2 2\beta y}$$

A maximum occurs when

$$2\beta y = (2k+1) \frac{\pi}{2},$$

in which

$$\beta = \frac{2\pi}{\lambda} = \frac{2\pi}{\frac{\Lambda + 2y}{m}}$$

so that we obtain

$$\frac{8y}{\Lambda + 2y} = 2k + 1,$$

where k is, like m , any integer.

It is thus possible, for a given length Λ of the electrode wire, to draw a chart, such as Fig. 2, which gives as a function of the length y of the transmission line the possible wavelengths which will be produced by the valve provided suitable electronic conditions for oscillations are obtained inside the structure.

Fig. 2 applies to a type of micro-ray valve for which $\Lambda = 21.5$ cm. Region (2) corresponds to a very short wavelength, and the length y for which this would be obtained falls within the bulb of the valve. It is, therefore, region (1) which is usually employed.

This corresponds to $m = 2$ and $k = 1$, and the maximum output is obtained when

$$\begin{aligned} y &= \frac{3\lambda}{8} = \frac{3\Lambda}{10}, \\ \Lambda &= \frac{5}{4}\lambda. \end{aligned}$$

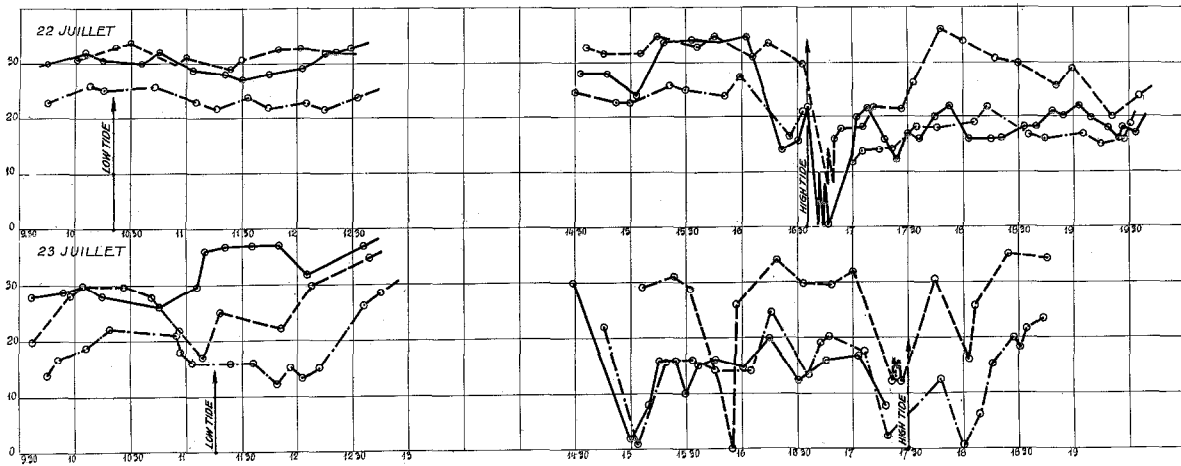

Fig. 7.

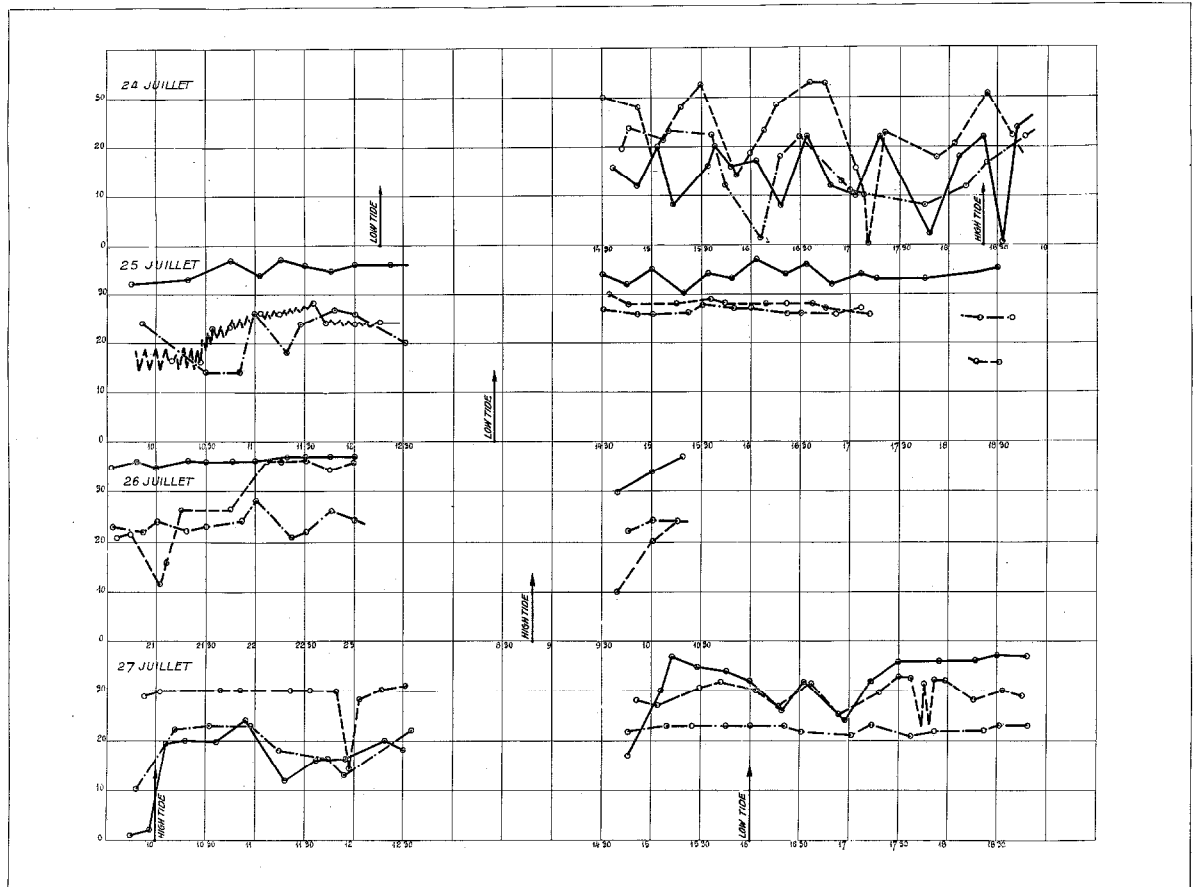

Fig. 8.

It must be remembered that this condition results from simplified theoretical considerations. But experiment gives the same order of magnitude and the same general sequence of oscillation frequencies.^{4, 5}

For instance, valves designed for an optimum wavelength of

$$\frac{21.5 \times 4}{5} = 17.2 \text{ cm.}$$

operated satisfactorily on that wavelength although a larger output was obtainable from the same valves on 19.4 cm., the length of the transmission line being then about 7 cm. Considering that this transmission line is far from possessing uniform properties as it must go through the glass of the bulb, the approximation obtained can be considered as satisfactory. Moreover, when applied to other valves designed for differ-

ent wavelengths, the order of magnitude has always been found to be correct, and in certain cases the agreement between theory and practice proved to be quite satisfactory, particularly for longer wavelengths (up to 30 cm.). For these longer waves the diameter of the oscillating electrode was larger and the apparent internal characteristic impedance was probably nearer to the impedance of the external transmission line. It was thus found possible to manufacture sets of valves suitably designed for different wavelengths, ranging from 10 to 30 cm.

As already mentioned, the tests were carried out between St. Margaret's Bay and Escalles where there were available the two experimental stations which had been erected for the original demonstration of a telephone micro-ray, cross-channel link in March, 1931. Each experimental station was provided with two reflectors only and, in order to make simultaneous observations

⁵ "Vacuum Tubes as High-Frequency Oscillators," by M. J. Kelly and A. L. Samuel, *Bell System Technical Journal*, Vol. 14, January, 1935.

on several wavelengths, one reflector of each station was equipped with two valves. Fig. 3 shows what arrangement finally was decided on in the experiments under review.

Fig. 4 shows the schematic of the circuits used at St. Margaret's Bay on the receiving side. Two valves V_1 and V_2 were used, the first one as a receiver for the 29 cm. wavelength and the second one as a receiver for the 20 cm. wavelength. The corresponding antennae A_1 and A_2 were placed at the focal region of the electro-optical system and at right angles. The 29 cm. receiving valve was mounted behind the paraboloidal reflector in the usual way, but the 20 cm. receiving valve was mounted behind the hemispherical mirror M_2 . As formerly indicated,⁶ the radius of this hemispherical mirror should, for optimum operation, be equal to an integral number of half

wavelengths. M_2 , having a radius of 29 cm., was practically suitable for both wavelengths. A switching arrangement I was used to receive either on one wavelength or the other.

The second reflector, at St. Margaret's Bay, was used for transmission on 18 cm.

At Escalles, one reflector was used to transmit on 20 cm. and to receive on 18 cm., and the second reflector was used to transmit on 29 cm.

On the transmitting side, modulation was effected by applying voltages in a suitable ratio to the oscillating and reflecting electrodes of the transmitting valve in a way which has previously been explained.¹ Great care was taken to apply constant voltages on the valves.

This equipment proved to be quite satisfactory and no appreciable perturbations occurred between the two different receiving equipments. The system was entirely symmetrical and very easily protected against bad atmospheric conditions, as shown in Fig. 5.

⁶ "Reflectors and Transmission Lines for Ultra-Short Waves," by R. H. Darbord, *L'Onde Electrique*, 1932, Vol. 11.

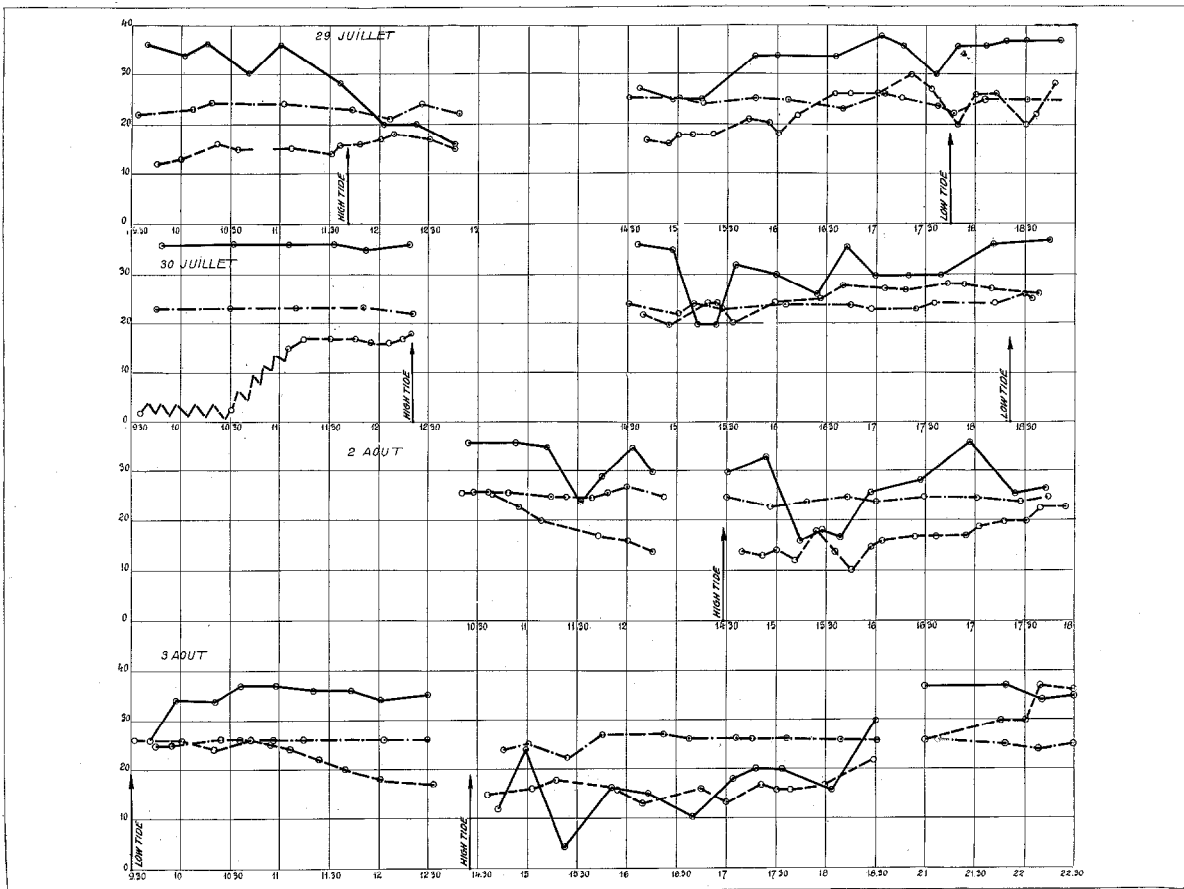

Fig. 9.

The method used for reception has previously been mentioned,³ but further explanation may be of interest. When the micro-ray valve is suitably adjusted, it can perform two different functions simultaneously. First, it can be made to oscillate on a micro-ray frequency and, secondly, it can be used to produce an intermediate frequency, this second frequency bearing no numerical relation whatever with the micro-ray frequency. Consider, for instance, in Fig. 4, the 20 cm. receiving valve. In circuit CO_2 , for suitable values of the voltages applied to the valve, an oscillation of micro-ray frequency F will be sustained, but in circuit $C_2L'_2$ there may also be produced oscillations of an entirely different frequency f . This frequency f is primarily conditioned by the circuit components C_2 and L'_2 , but it also depends on the apparent capacity offered by the micro-ray valve. This capacity is, so to speak, shunted across condenser C_2 .

This valve capacity has been found to vary according to the micro-ray voltage applied across the oscillating electrode. This can be explained as a result of a variation of the dielectric constant of the medium between the valve electrodes, the variation being caused by a corresponding variation of the density of electrons in the same medium.

When an incoming micro-ray wave of suitable frequency is impressed on antenna A_2 , the high frequency potential along the oscillating electrode is varied and the apparent capacity shunting C_2 is also varied. These variations follow the change in amplitude of the incoming micro-ray wave. Therefore, the frequency which is produced in circuit $C_2L'_2$ undergoes a variation, and a frequency modulation of the intermediate frequency f is obtained, its amplitude remaining substantially constant for suitable adjustments of the voltages impressed on the micro-ray valve.

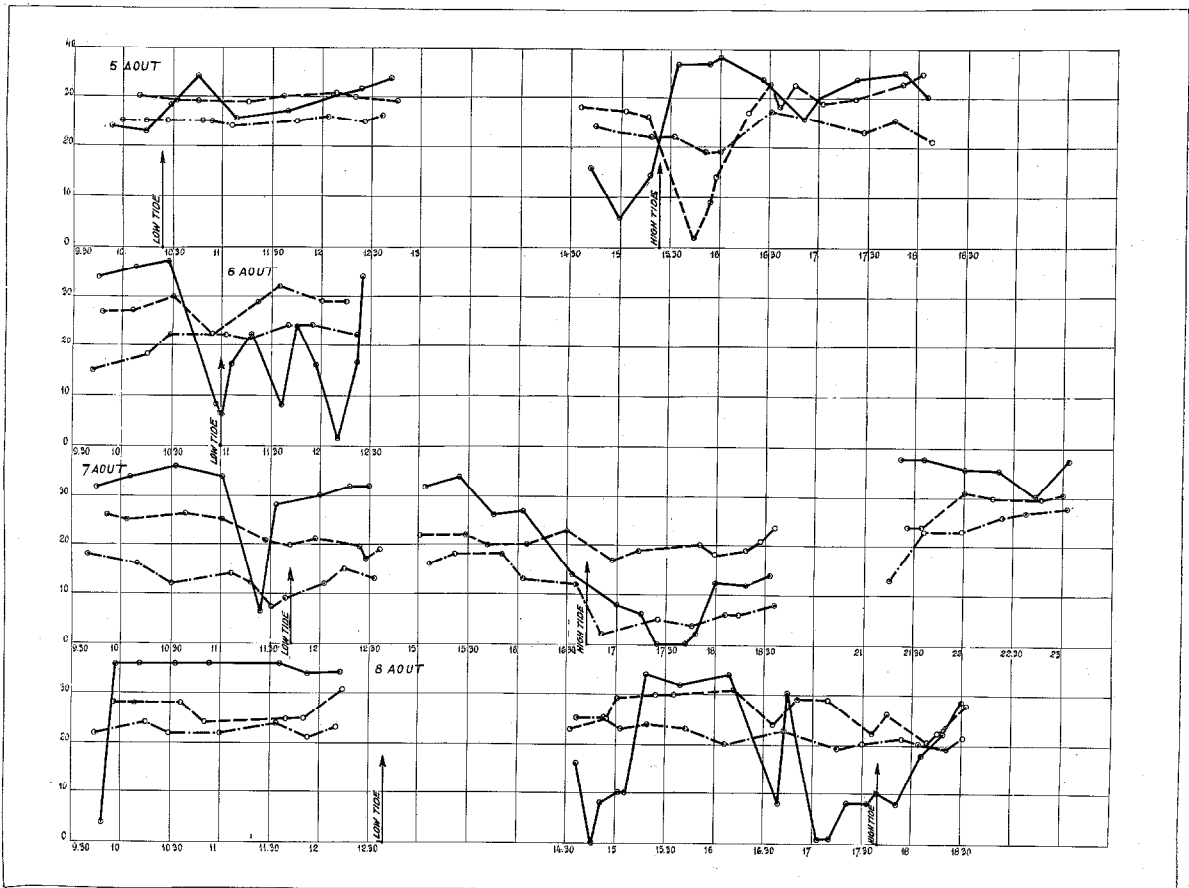

Fig. 10.

This local frequency modulated wave is subsequently transformed into an amplitude modulated wave by means of a resonant circuit and is then passed to the usual amplifying and detecting equipment. Additional low frequency amplification may be used, followed by a second detection, the signal then being applied to a standard volume indicator.

It is easy to adjust the 29 cm. receiving valve so that the intermediate frequency produced in circuit L_1C_1 is the same as that produced in circuit $C_2L'_2$ in the absence of any external micro-ray signal.

Comparison between signal levels and local noise levels can then be effected easily by means of the switch I . A series of long dashes was sent from the transmitters at frequent intervals, and measurements were based on the number of decibels of attenuation which it was necessary to take out of the measuring circuit in order to bring the noise level up to the same level as the signal. The results of the measurements are given on the accompanying charts (Figs. 6 to 10 inclusive). Though such results do not lead to any clear explanation of the propagation circumstances, they have definitely proved that these circumstances differ widely according to the wavelengths used, at least on the circuit under investigation.

The effect of the tide appears to be masked by irregularities in the flow of water in that part of the English Channel over which transmission took place. Certainly, results varied from day to day and transmission conditions appear to be different when the sea is smooth or rough.

Local interference in front of the receiving reflector is of very great importance. People walking along the cliffs caused very large sudden changes in the received signal strength. A similar effect occurred when ships were crossing the line of the beam at a certain distance. It can thus be inferred that an important part of the signal strength instability comes from the changes in the local interference pattern.

The effect of purely meteorological conditions could not be detected with reliability. As previously noticed, fading is apt to occur more frequently when the weather is hot, the humidity

high, and the wind light. The signal strength on all three wavelengths was, as a rule, more stable in the morning than in the afternoon.

Reliable measurements have been taken for 117 hours during which the 18 cm. signal strength remained 18 db. above noise level for 99 hours; the 20 cm. signal strength remained 18 db. above noise level for 94 hours; and the 29 cm. signal strength remained 18 db. above noise level for 96.5 hours; that is, 84.6% of the time for 18 cm.; 80% of the time for 20 cm.; and 82.5% of the time for 29 cm.

If we now compute the percentage of time during which a combination of any two wavelengths would have produced signals remaining 18 db. above noise level, the following results are obtained:

- 18 cm. + 20 cm.—94% of the time;
- 18 cm. + 29 cm.—90% of the time;
- 20 cm. + 29 cm.—96.6% of the time.

These results, which apply to a period of time which was particularly unfavourable to micro-ray propagation, bear out the conclusion that the use of two wavelengths would definitely improve traffic reliability on the circuit under investigation.

Another interesting result from the tests was the development of a new method for receiving continuous wave micro-ray telegraphy.⁷

Referring again to Fig. 4 and considering, for instance, the 20 cm. receiving valve, the frequency f of the local oscillations in circuit $C_2L'_2$ can be adjusted in the absence of incoming signals to give a zero beat-note with a local stable auxiliary oscillator φ . As soon as a signal, a dash for instance, arrives on antenna A_2 , the frequency of the local oscillation produced in $C_2L'_2$ is altered and becomes f_1 , and the altered intermediate frequency f_1 and the local stable frequency φ produce a beat-note $\varphi - f_1$ in the detector equipment. If the amplitude of the signal impressed on A_2 varies within certain limits, the frequency of the beat-note obtained varies correspondingly, but not its amplitude, so that the system to a certain extent provides a means for the correction of fading.

⁷ Brevet Français 801.196.

Some Examples of Growth Curves*

By H. C. PLESSING,

Chief Engineer, Jydsk Telefon-Aktieselskab, Aarhus, Denmark

SUMMARY: The present contribution first explains the application of growth curves in some special cases in the field of telephony and the importance of knowing the laws of growth in this field. Later it is shown how it is possible to adapt such curves to represent the increase in the number of subscribers within districts with different possibilities for development, and finally how the depreciation of composite plants may be influenced by growth curves of the kind treated here.

Introduction

ONE of the first problems to present itself in engineering a telephone plant is the question of the incorporation of suitable reserve equipment.

In order to answer this question, it is necessary to make an estimate in each case of the increase to be expected in the number of subscribers or conversations in a period corresponding to the life of the plant under consideration, including not only the district but also connecting traffic centers. As every essential alteration in the increase thus estimated affects the profitableness of the plant, it is important to know the laws of the movements and growth involved.

Professor Axel F. Enström's article "Framstegslinien" (The Growth Curve) in the *Nordisk Tidsskrift for Teknisk Økonomi*, Nr. 1, 1935, prompted the author to take up some previously commenced investigations relating to increase in the number of subscribers and telephone density (i.e., number of subscribers per 100 inhabitants) within districts having different possibilities for development. A brief account of the results obtained may be of interest to readers of this journal.

Growth Curves

When estimating future growth, it seems natural to build on the knowledge of the development in the immediately preceding years, and it would appear that the estimated growth may be represented by the tangent to the progress curve. If this curve, however, has the

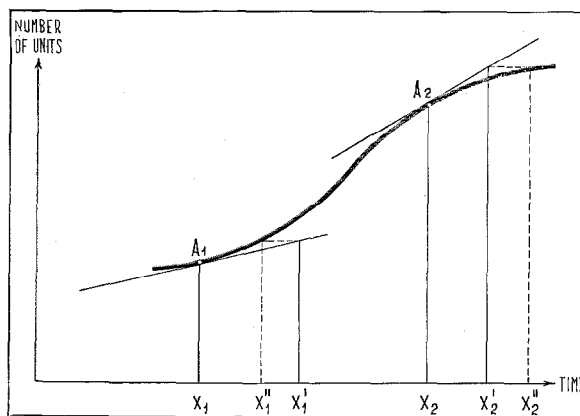

Fig. 1.

appearance shown in Fig. 1 and the size of the plant is determined according to the tangent at A_1 , including a reserve intended to meet requirements for the period $(x_1$ to $x_1')$, the plant would actually be filled up prematurely by $(x_1''$ to $x_1')$ years. The opposite would be the case if the plant were designed according to the tangent at A_2 ; in this case the plant would cover the needs for $(x_2''$ to $x_2')$ years longer than intended.

If the increase is considered not to progress linearly, it can be represented within limited periods by either:

$$y = ce^{bx} \quad (1)$$

$$y = a - ce^{-bx} \quad (2)$$

Curve (1), representing an infinitely increasing growth, assumes: firstly, an unlimited potential expansion in the number of units; and, secondly, a fixed ratio between the rate of increase $\frac{dy}{dx}$ and

the number of units, y , currently required (see Table I). c , for example, may represent invested

* Translated and Reprinted from "Nordisk Tidsskrift for Teknisk Økonomi" (Nordic Journal of Technical Economy), Nr. 5, September, 1936.

capital earning a return at compound interest, and b the "force of interest," where $b = \log_e(1+r)$ and r is the rate of interest per annum.

Curve (2), on the contrary, assumes: firstly, limited potential expansion in the number of units, the curve becoming asymptotic to $y=a$; and, secondly, a fixed ratio between the rate of increase $\frac{dy}{dx}$ and the number of future units required (see Table I).

In a transition period—possibly as a connecting link between (1) and (2)—the increase may be represented by the above mentioned linear form of growth for which $\frac{dy}{dx}$ is constant.

As the growths investigated were all similar to that shown in Fig. 1, the three above mentioned curves could only be used to represent growth within limited periods; and it was therefore natural to attempt to find a single curve which could represent the whole course. As likely to fit the purpose, amongst others, two curves in the above mentioned article, and proposed by Pearl and Reed and Professor Axel F. Enström, respectively, were tried. Both have been employed to represent different courses of production.

In the expression for the first of the two proposed curves, a constant c was introduced for adjustment, thereby giving it the form in which it was tried:

$$y = \frac{a}{1 + ce^{-bx}} \tag{3}^1$$

¹This equation is also used to represent growth of population, see for instance "The Biology of Population Growth," by Raymond Pearl, New York, 1925.

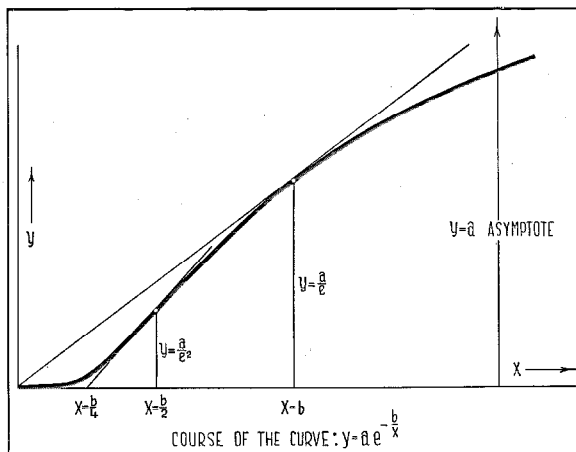

Fig. 2—Course of the Curve: $y = ae^{-\frac{b}{x}}$.

This curve, however, is symmetrical with respect to the inflexion-point. None of the growths investigated, however, displayed this characteristic; and, since it developed that the second curve,

$$y = ae^{-\frac{b}{x}} \tag{4}$$

fitted particularly well for the representation of the growths under investigation, this curve only was used.

The appearance and application of this curve to the representation of production is described in the previously mentioned article.² It shows, as will be evident from Fig. 2, some simple properties, particularly as regards coordinates and tangent; that is, the point of inflexion and the point at which the tangent passes through

² See further: "Om Kärnlinier i ekonomisk-statistiska kurvor," *Ymer*, by A. F. Enström, 1925, Nr. 3 and 4.

TABLE I

$y=f(x)$	$\frac{dy}{dx}=f'(x)$	$\frac{d^2y}{dx^2}=f''(x)$	Some Characteristic Coordinates		
			for $x=0$ is	Inflexion Point	Asymptote
$y = ce^{bx}$	by	b^2y	$y = c$		
$y = a - ce^{-bx}$	$b(a-y)$	$b^2(y-a)$	$y = a - c$		$y = a$
$y = \frac{a}{1 + ce^{-bx}}$	$\frac{b}{a}y(a-y)$	$\frac{b^2}{a^2}y(a-y)(a-2y)$	$y = \frac{a}{1+c}$	$x = \frac{\log_e c}{b}; y = \frac{a}{2}$	$y = a$
$y = ae^{-\frac{b}{x}}$	$\frac{by}{x^2}$	$y \frac{b(b-2x)}{x^4}$	$y = 0$	$x = \frac{b}{2}; y = \frac{a}{e^2}$	$y = a$

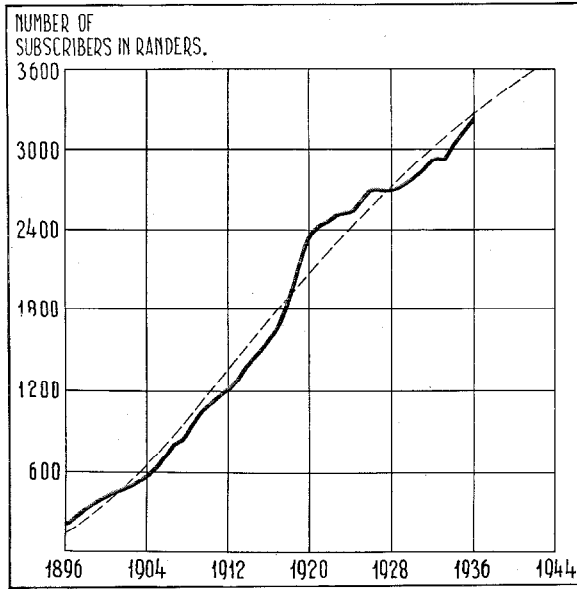

Fig. 3—Development of the Number of Subscribers in Randers
 Number of Subscribers as of January 1, 1936..... 3,235
 Number of Inhabitants as of January 1, 1936
 approximately 39,200

the origin. This curve is thus easy to adjust.³ The main data concerning it and the above mentioned curves are given in the table below:

Practical Application of the Curve $y = ae^{-\frac{b}{x}}$

Figs. 3 to 5 illustrate the application of this curve to the net increase in the number of subscribers in Jutish towns in the period 1896⁴–1936.

The computed curves are shown in dotted lines.

From the curves—see for instance the one representing the net increase in the number of subscribers in Randers—it will be seen how differing conditions in the two periods before and after the Great War gave rise to perceptible deviations from the computed curve. All the cases treated seemed to have the character of a “secular trend.” By further attempts with similar representations of increase in the number of subscribers in other Jutish towns of different size, quite corresponding results were obtained.

³ Some mathematical properties of a similar curve $y = e^{\frac{1}{x}}$ are also described in “Cours d’Analyse,” by Ch. Sturm, Paris, 1905, p. 313.

⁴ The year when the Jydsk Telefon-Aktieselskab was founded by the fusion of a number of different minor companies.

In the cases investigated the starting point of the curve was fixed in the period 1882–1884, corresponding to the time when the increase in the number of telephones commenced in the towns concerned; and it was possible to place the inflexion point in the period 1912–1916.

For some few towns, and especially Aarhus (see Fig. 4), where the growth has had a linear character over a longer period and where, consequently, some uncertainty prevailed regarding the position of the inflexion point, it is possible that future development will prove that the inflexion point should be advanced somewhat.

A similar mathematical representation of the increase in telephone density within a certain district will be somewhat more complicated, because it will appear as the ratio between two curves with different conditions of growth (number of inhabitants and number of subscribers).

Conclusion

In addition to being used, as mentioned in the introduction, for determining the initial cost of the plant and for throwing light on the number of revenue yielding units within a particular district, growth curves of the kind treated here may also directly influence the calculation of the depreciation rate (per cent. per annum) for

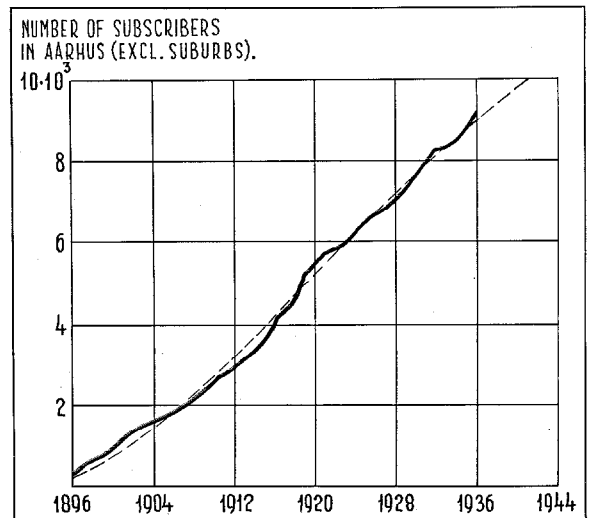

Fig. 4—Development of the Number of Subscribers in Aarhus (excluding Suburbs)
 Number of Subscribers as of January 1, 1936..... 9,185
 Number of Inhabitants as of January 1, 1936
 approximately 90,500

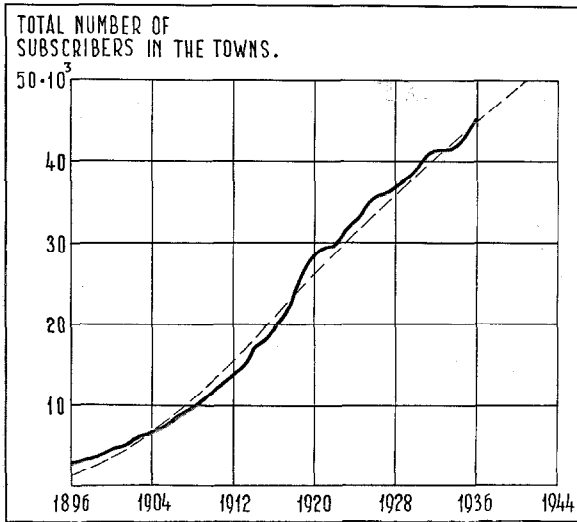

Fig. 5—Development of the Number of Subscribers in All Towns in the Territory Served by the Jutland Telephone Company

Number of Subscribers as of January 1, 1936. 44,987
 Number of Inhabitants as of January 1, 1936
 approximately 517,500

composite plants constructed at different times but scrapped simultaneously.

The calculation of the depreciation of such composite plants is treated thoroughly by Professor P. O. Pedersen in an article, "Afskrivning paa tekniske Anlaeg" in "Polyteknisk Tidsskrift, Ingeniør og Samfund," Nr. 7-12, Copenhagen, 1929.⁵

Only a single typical example near at hand, therefore, will be briefly cited, i.e., pole lines with open wire.

⁵ This article has been reprinted in somewhat abbreviated form: "On the Depreciation of Public Utilities," by P. O. Pedersen, included in: "Miscellaneous Papers," Copenhagen, 1934.

If such a plant is built with a certain number of wires, which increase in proportion to the increase in the number of subscribers, a moment may arrive when it may, for different reasons, be considered advisable to take down a greater or lesser number of the wires and replace them with underground cables. The wires removed will then be of different age, and there will be among them some which, while not entirely depreciated, represent little or no value when taken down. Since the calculation of the rate of depreciation for the whole group of wires is based on its average life, the curve representing growth will influence the calculation of the average life that determines the depreciation rate in question.

Attention may finally be called to the following circumstances. The telephone density may differ widely in different quarters, especially in the larger cities where this difference can be very pronounced. In addition to knowing the growth curves of the kind herein treated, for the different quarters, it is therefore necessary further to know something of the character of the future developments relating to the building up of the town, and this not only for the suburban quarters, but also for the central portions, since centrally located quarters with small telephone density are frequently transformed into business sites with great telephone density.

For an engineer employed in the planning of extensions of telephone plant in a town of considerable size, the building plan of the town, if available, may therefore also provide a valuable aid.

X-Rays in Vacuum Tube Manufacture

By W. T. GIBSON, O.B.E., M.A.

Standard Telephones and Cables, Limited, London, England

and

G. RABUTEAU

Les Laboratoires Le Matériel Téléphonique, Paris, France

ROENTGEN, in 1895, while experimenting with highly exhausted vacuum tubes, discovered that under certain conditions they emitted invisible rays with unique properties. Once a scientific curiosity, these rays—designated as X-rays because of uncertainty as to their nature—have become one of the most important tools available to modern industry.

The rays are produced when high speed electrons are stopped suddenly by collision with a metal anode. While for a long period the nature of the rays remained undecided, it was finally shown by Bragg that it was electromagnetic radiation of a wavelength considerably shorter than that of visible light. Von Laue and Bragg showed how it was possible to obtain diffraction effects by using a crystal as a diffracting grating. However, except in the special arrangements adopted to make use of this effect, as in X-ray crystal examination, the radiation can be considered as traveling in straight lines and not being subject to reflection or refraction.

The important characteristic for radiographic work is absorption, which varies with the material and which is a property of the atoms and not of the chemical compounds. The heavier the atoms, the greater is the absorption. The wavelength of the radiation produced by the X-ray tube decreases as the voltage applied to the tube increases, and at the same time it becomes more penetrating. Consequently, for the examination of objects of heavy materials, it is necessary to use high voltages.

The intensity of the radiation increases as the current through the tube increases. This does not affect the penetration of the rays but reduces the exposure required to obtain a negative of given density.

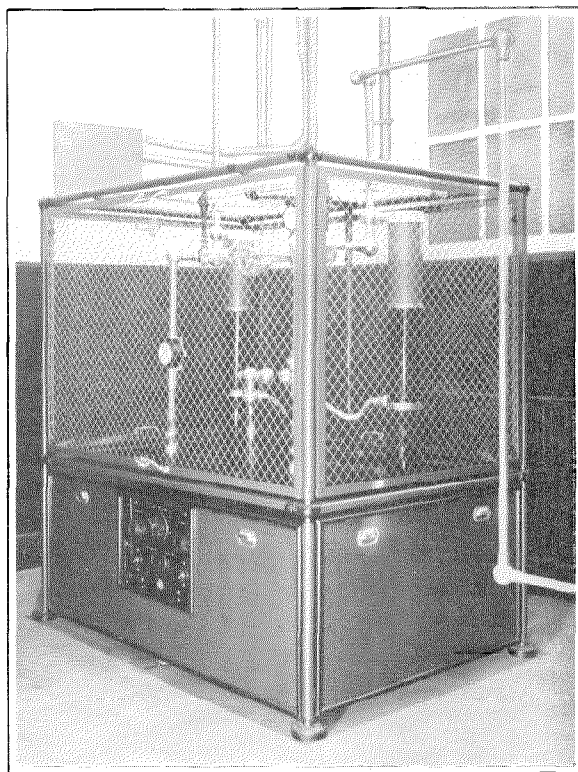

Fig. 1—High Tension Rectifier—Les Laboratoires Le Matériel Téléphonique, Paris.

In industrial radiography of vacuum tubes, the chief application is the photography of the interior of water cooled tubes through the anodes. These anodes may consist of 1.5 cm. total thickness of copper and the objects to be observed, i.e., the filament and grid structures, consist chiefly of molybdenum or tungsten which are to be seen by contrast on the negative. For this purpose, the most useful X-ray tube voltages are from 140,000 to 180,000 volts. The tube equip-

ment, therefore, involves a high tension generator for providing these voltages and a tube current of the order of 3 or 4 milliamperes, as well as the electrical protective features necessary for safely handling the equipment.

The high tension generator may take one of a number of forms. For the high voltage work with which the authors are dealing, it is customary to supply the X-ray tube with unidirectional current so that some form of rectifier must be used. The X-ray tube itself acts as a rectifier but it is unsatisfactory for this purpose when working with high power, inasmuch as the target may operate at a temperature sufficiently high to emit electrons. In this event, breakdown would occur when the tube ceases to act as a rectifier. Mechanical rectifiers are used to some extent but are, of course, very cumbersome and noisy; both the installations to be described below operate with valve rectifiers.

The X-ray tube itself consists of a highly evacuated glass bulb provided at one end with a stem carrying a filament and, at the other, a stem carrying the target or anticathode, which is located close to the filament. The filament is a

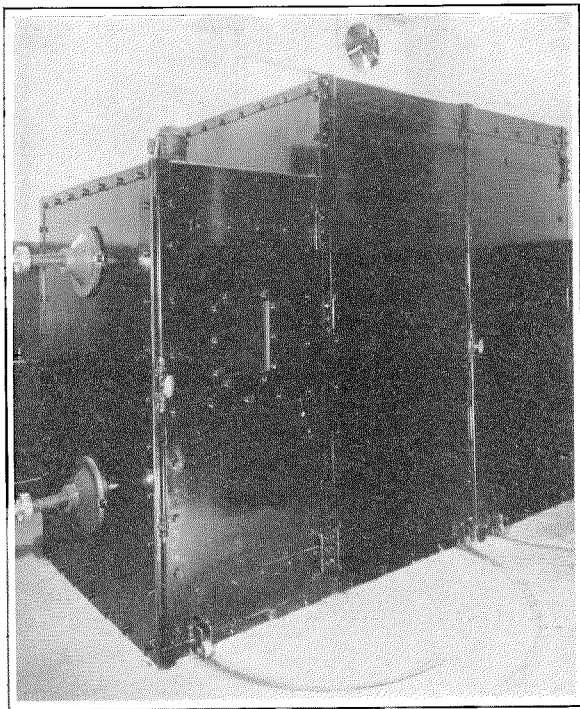

Fig. 2—X-Ray Chamber, Paris Laboratories.

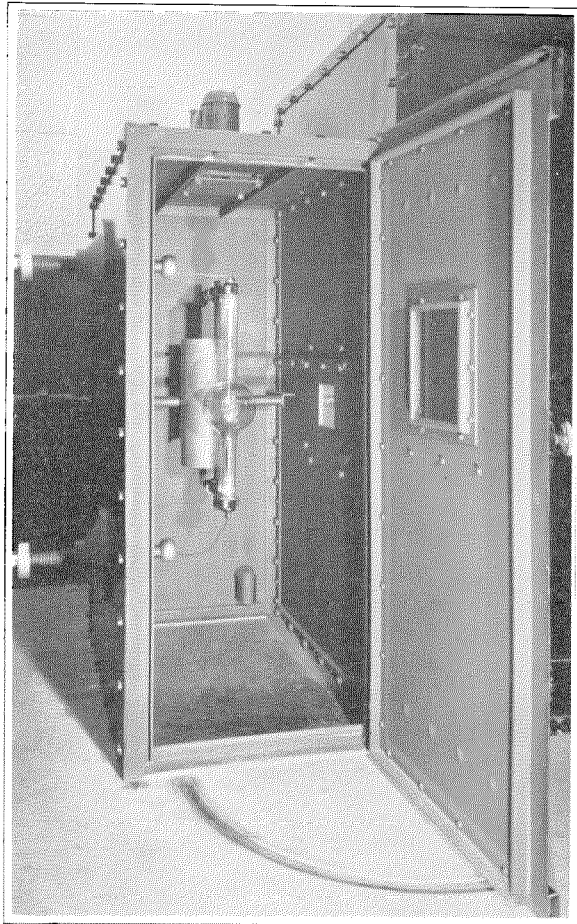

Fig. 3—X-Ray Tube Compartment, Paris Laboratories.

coiled tungsten wire heated by a current to a temperature such as to provide a total emission of the required value. The anticathode is a button of tungsten mounted on a water cooled copper rod or on a massive tungsten rod. The face of the anticathode is at an angle to the direction of arrival of the electrons. The high voltage is applied to the tube with the positive pole connected to the anticathode, the electron current from the filament causing intense bombardment and producing the X-radiation. Since the anticathode operates at an extremely high temperature, the recommended maximum ratings for the tube must be strictly adhered to or it may be permanently damaged.

When X-rays strike any object, part of the energy is scattered in all directions from it with a longer wavelength. This is called secondary

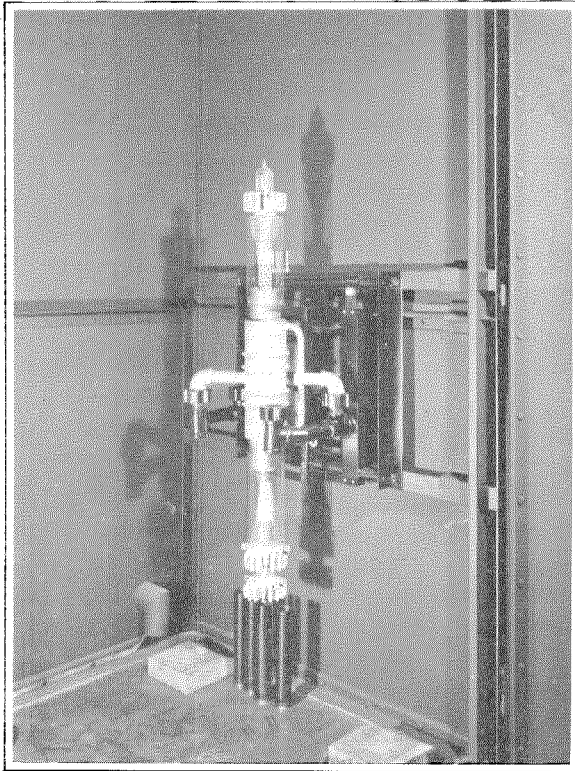

Fig. 4—Interior of Right-Hand Compartment of X-Ray Chamber with Vacuum Tube in Position.

radiation and it in turn, falling on other objects, will be scattered again.

This radiation is, therefore, very difficult to control, and the only way of stopping it is by the use of an appropriate thickness of lead sheet, say 3 millimeters. It must, however, be properly controlled for the safety of the operator since the effect of small doses is cumulative and can lead eventually to anaemia and general debility. It is, therefore, necessary to take suitable protective measures and also to provide for periodical medical examination of the operators who might be exposed to the radiation. The examination, apart from a general one, usually involves a count of the red corpuscle concentration of the blood.

The problem of protection of staff can be solved in two ways, and the installations in the Paris Laboratories and in the Valve Department of Standard Telephones and Cables at Woolwich represent the different methods.

In the Paris installation, a rectifier unit consisting of a high voltage transformer and suitable high vacuum rectifiers is installed in a room which is completely separated by grounded screens from the operating section. The high voltage is fed into the X-ray tube chamber in which an air cooled tube is mounted. This whole chamber is built of lead with tightly fitting doors, and is provided with a window having a lead shutter for the admission of the radiation to the camera box, which is a very large lead box with heavy lead doors and which contains the support for the object to be radiographed and the film. The X-ray tube and the object being examined are thus completely en-

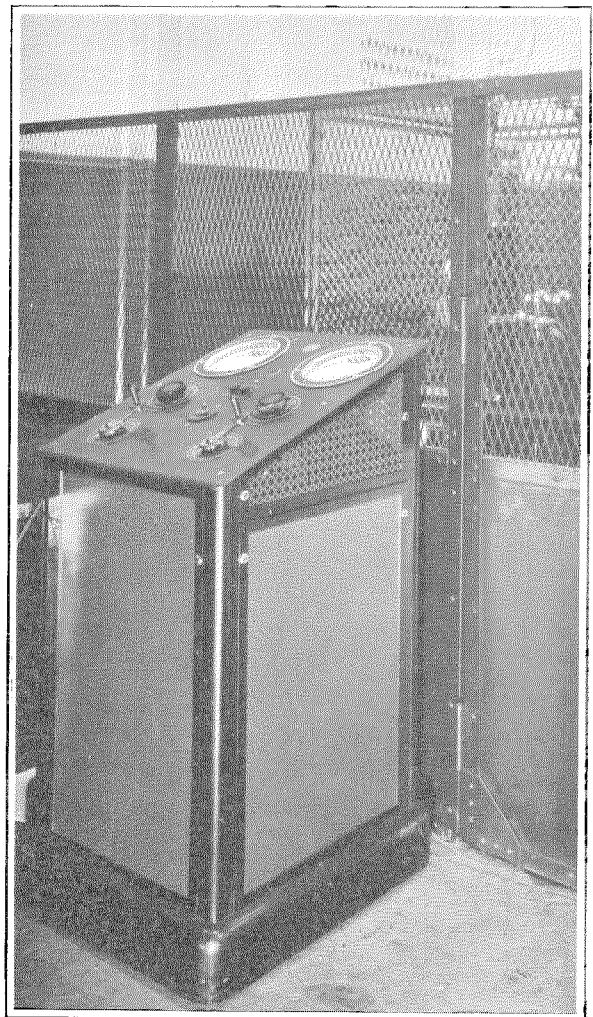

Fig. 5—Control Desk, Paris Laboratories.

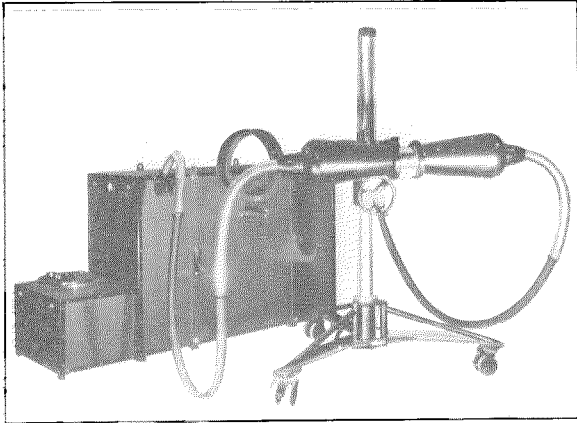

Fig. 6—Complete X-Ray Unit, Valve Department, Standard Telephones and Cables, Limited, Woolwich.

closed in lead and the operator is quite protected from radiation.

Fig. 1 shows the high tension rectifier which comprises a high voltage transformer having its mid-point earthed, two half-wave high tension tungsten filament rectifiers, two high tension condensers and the necessary filament transformers, voltmeter and control for the adjustment of the filament voltage of the rectifier tubes, and the X-ray tube.

The unit is fully protected by appropriate earthed screens. The positive and negative terminals of this rectifier, which is rated to deliver continuously 200,000 volts and 10 milliamperes d-c., are connected to aluminium bus bars of a diameter large enough to avoid Corona effect.

Fig. 2 shows the X-ray chamber which is an iron frame covered with 5 mm. lead and provided with doors giving access to two different compartments. The compartment on the left contains the X-ray tube; the other, the vacuum tube to be examined.

Fig. 3 shows the X-ray tube compartment, the door being open. The X-ray tube, which is of the air cooled type, is mounted on appropriate insulators. The high tension is fed to the cathode and anode of the tube through bushings fixed on the panel at the left of the chamber and made with an insulating material containing a considerable amount of lead oxide in order to prevent X-ray radiations from passing through them.

A fan is arranged on the top of the X-ray tube

chamber for removing the ozone produced in the chamber by the high voltage field around the conductors.

A glass window on the front door enables the operator to supervise the operation of the X-ray tube. The glass used for this window contains about 20% of lead and its thickness is great enough to provide the same protection as that of the other parts of the chamber.

Fig. 4 shows a view of the interior of the right-hand compartment of the chamber with a vacuum tube in position for examination.

The tubes can be placed in position in a few seconds by means of appropriate supports. Each tube to be examined is photographed in two directions at suitable angles depending on its inner construction. The tube supports are arranged so as to determine with accuracy the position of the tube for each of the two photographs taken. From the latter, the location of any part inside the tube can be accurately determined.

Provision has been made to render possible, when required, the application of filament voltage

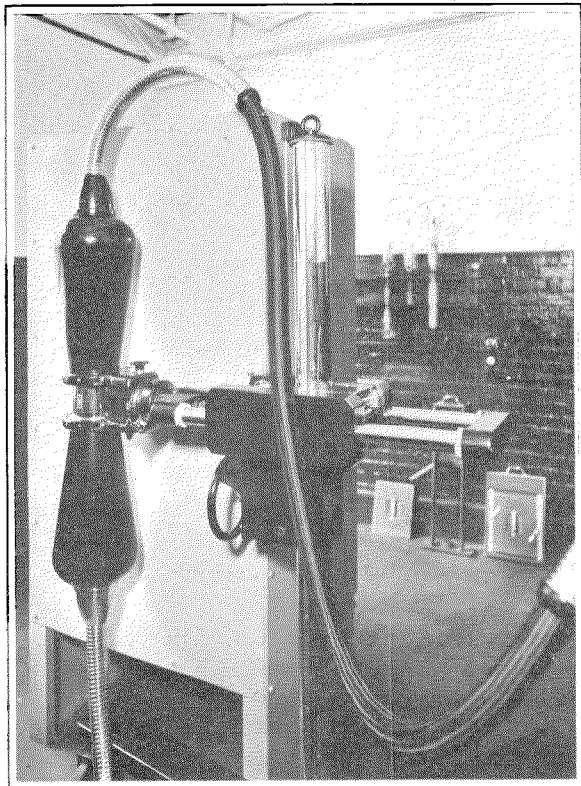

Fig. 7—X-Ray Tube and Camera, Woolwich.

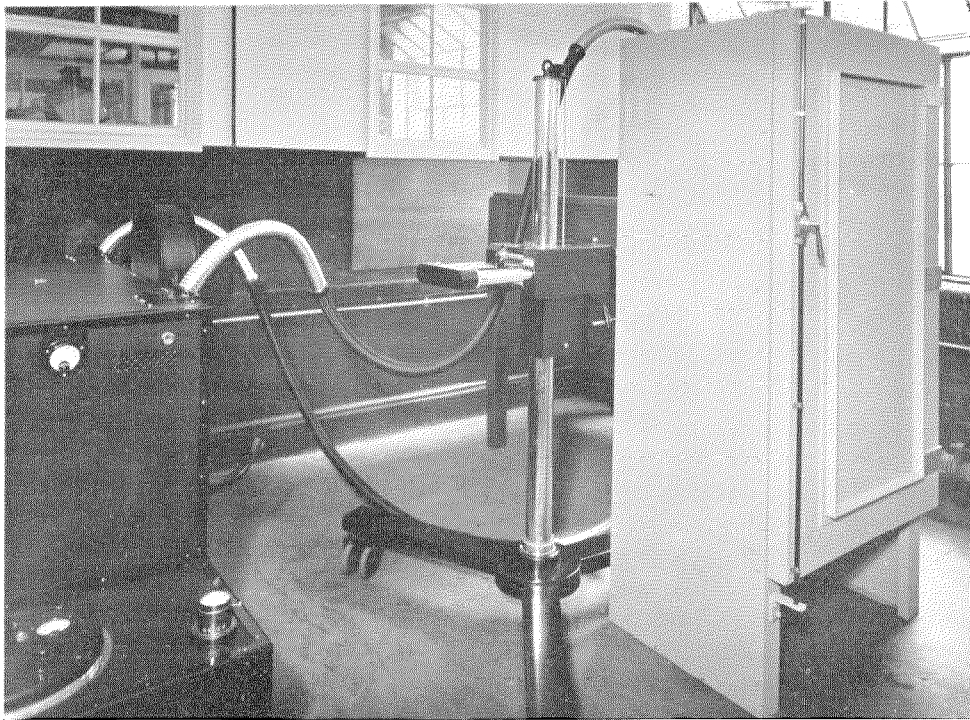

Fig. 8—Installation for Routine Examination of Water Cooled Tubes, Woolwich.

to the tube during examination, so that deformation of the filament when hot or during the heating and cooling cycle can be recorded.

The film is contained in a suitable chassis having an aluminium window which is held in position by means of appropriate rails, one of which can be seen on the right of the tube in Fig. 4.

Fig. 5 shows a view of the control desk which comprises devices for the remote control of the output voltage and current together with the necessary meters. A push button controls the contactor applying the high voltage. In order to protect the operators, contacts mounted on the door remove the power as soon as a door is opened.

The equipment installed in the Valve Department of Standard Telephones and Cables, on the other hand, consists of what is called a self-protected X-ray unit. Fig. 6 shows the complete

unit. The large steel box contains all transformers, rectifiers, insulated water circulating pump and water cooling radiator together with control gear. The tube is shown mounted on its stand and in its housing. The X-ray tube has a water cooled target and is connected to the high voltage generator unit by flexible cables. One of these contains, in addition to the negative lead of the H.T., wires for the filament supply. The other contains the positive lead of the H.T., and inlet and outlet hoses for the water cooling, the water being circulated by the insulated pump and passing through the radiator in the transformer box. The flexible cables are metal sheathed and earthed. The X-ray tube itself is completely surrounded by a metal earthed shield. The whole unit is thus completely electrically protected. The mid-point of the high tension circuit is earthed and thus the cables have to support 90 kilovolts each.

The X-ray tube shield is also a very efficient radiation screen and the intensity escaping, except via the window, is reduced to a safe level.

The X-ray tube used in this equipment is of special type, which has a grid between the filament and anode. A negative voltage is applied to this grid in such a way that the anode current only flows at the time when the anode voltage is close to its peak value. As a result, the heating of the anode only takes place at the moment when the most useful rays are being produced, thus increasing the effective rating of the tube, and at the same time there is a very considerable reduction in radiation of the unwanted softer rays.

The tube is mounted on a universal stand, and its position can be adjusted rapidly for any special use. For the general work of photographing water cooled tubes, the window of the tube is placed in contact with the window of a large lead cabinet which is fitted with special tube holders and film carriers so that the time

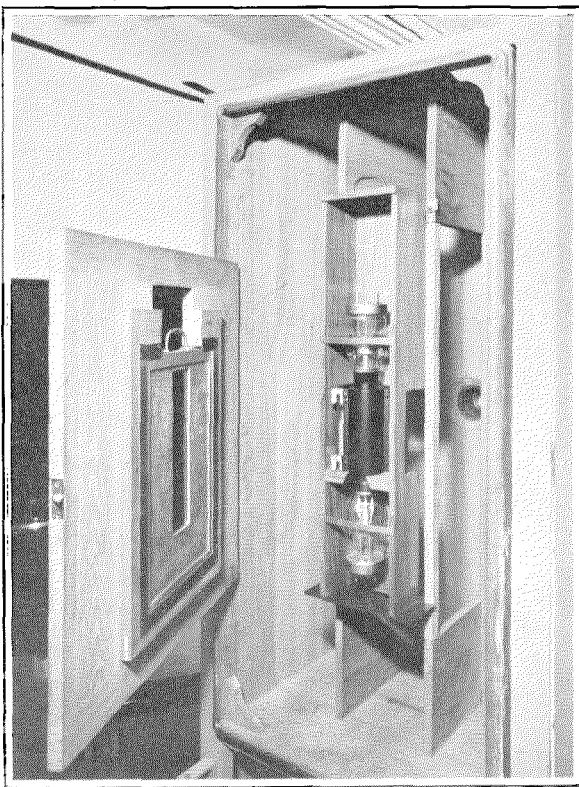

Fig. 9—Interior of Camera showing a Vacuum Tube in Position for Examination, Woolwich.



Fig. 10—Radiograph taken with Lead Table Set-Up.

required to set up for a picture is reduced to a few seconds. The whole apparatus is controlled by a single push button plus a voltage selector. The tube in position against the camera is shown in Fig. 7.

This equipment, being flexible, can fairly easily be set up for any special and unusual job or even be moved bodily to another part of the factory

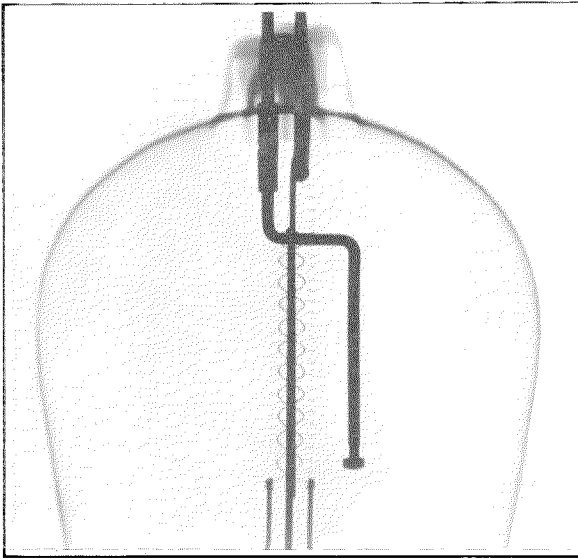

Fig. 11—Radiograph of the 4304-A Vacuum Tube. This Tube has a Carbon Anode, which is Invisible in the Reproduction.

for the examination of equipment that cannot be moved. Recent jobs have included the examination of the welds of parts of machinery in pieces 14 feet long.

Two self-starting electric clocks are provided, one of which measures the filament burning time of the X-ray tube, and the other the total time of application of the high voltage.

Fig. 8 shows the installation at the Woolwich factory for the routine examination of water cooled tubes. The cabinet on the right is the camera, made of thick lead.

Fig. 9 is a view of the interior of the camera and shows a vacuum tube in position for examination. Tubes can be placed in position in a few seconds with very exact positioning. The hinged door on the left carries intensifying screens, if used, and the film holder.

The actual process of taking the radiograph is sometimes carried out with, but more usually without, intensifying screens. In either case, a thin steel screen is placed between the vacuum tubes and the film to improve the contact. The exposures are short and rarely exceed one minute.

While the majority of the work handled is of a routine nature capable of being quickly dealt with by this apparatus, it often happens that it is

necessary to examine other articles. For this purpose a heavy lead table has been built. The lead is wood covered but gives very considerable protection to the operator. The tube in this case is used in a horizontal position. Fig. 10 is a radiograph of a piece of apparatus for which this set-up was employed.

The normal routine in Standard Telephones and Cables requires that every water cooled tube be photographed during its manufacture in two directions at right-angles. New types of tubes are often photographed a greater number of

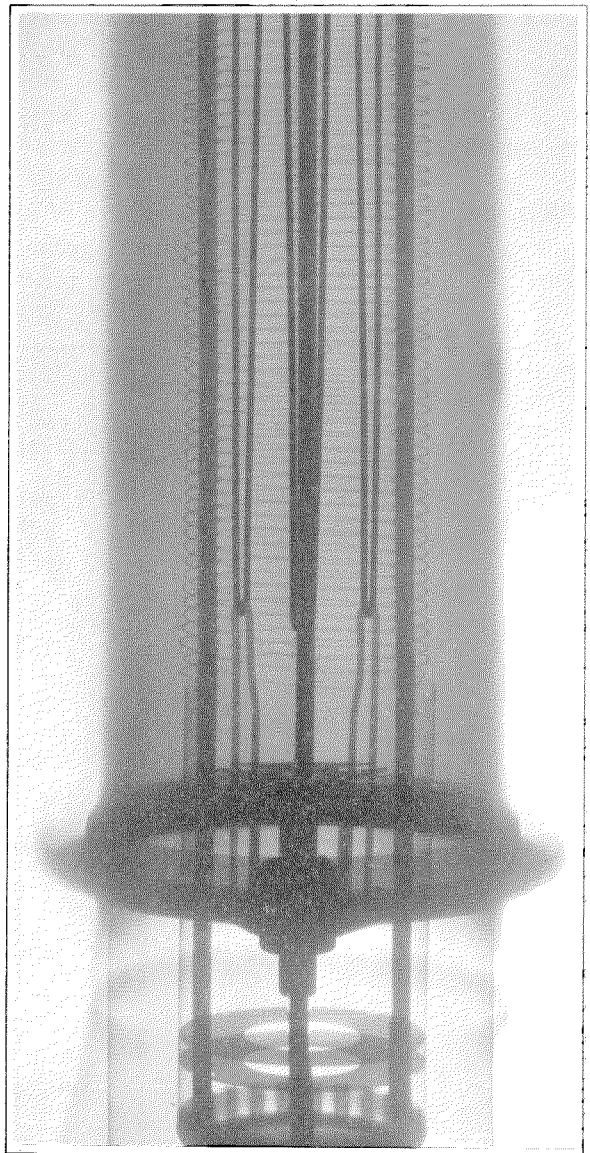

Fig. 12—Radiograph of Part of a 4030-B Vacuum Tube.

times until all manufacturing troubles have been eliminated.

The process has been found of very great value in improving the quality of the tubes, and the defects which are completely eliminated, for instance, are such as:

Inaccurate centering or alignment of electrodes,
Distortion of electrodes during exhaust,
Thin spots in anodes,
Burnt out, distorted, or loose turns on grids,
Filament anchor connectors not screwed completely home.

Figs. 11, 12, and 13 illustrate typical radiographs.

The use of this equipment has undoubtedly prevented the shipment of apparently perfect tubes which contained hidden defects. The rejection of work as a result of examination of the radiographs also has had a certain moral effect on the operatives, resulting in a very marked improvement in the standard of the work.

While the main function of the apparatus is the radiography of water cooled tubes, it is frequently found to be of value to photograph glass tubes, especially of the multi-electrode type, to determine the reasons for defects. Previously, when such tubes were cut open for examination, the process of dissection itself disturbed the very errors of assembly, etc., for which search was being made. In such cases, two photographs are often taken, the X-ray tube being slightly displaced between the exposures. The negatives are then examined in a stereoscope to give a good idea of the spatial arrangement of the electrodes.

The X-ray apparatus has proved itself an indispensable tool in vacuum tube manufacture and its value is such that its application will gradually be extended to wider fields in the manufacture of communication apparatus.

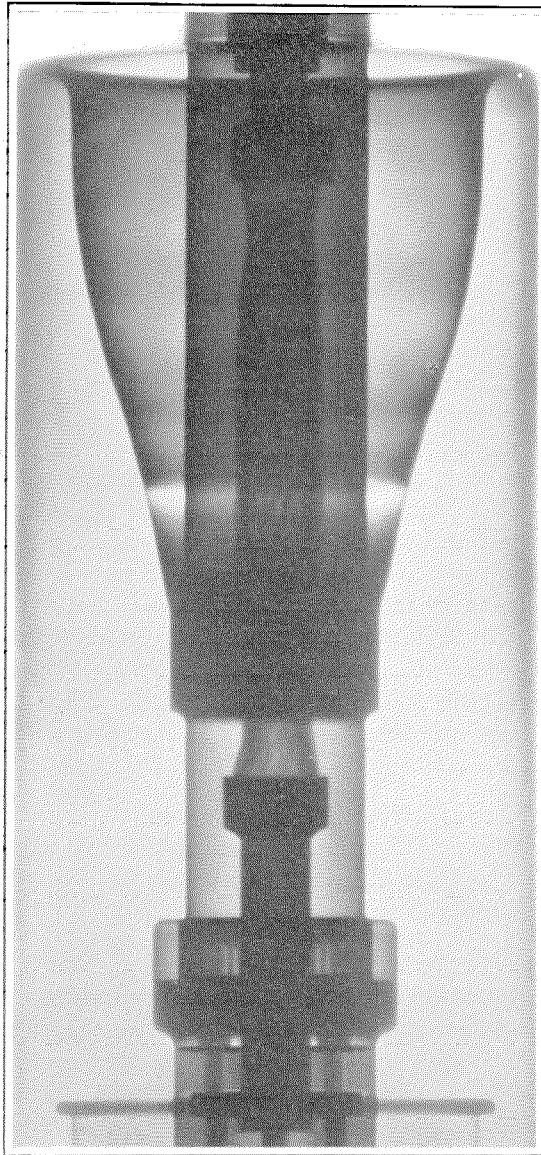

Fig. 13—Radiograph of the Filament Stem of a 4030-B Vacuum Tube, showing Concentric Filament Leads and the Flexible Nature of the Inner Lead.

An Experimental Television Transmitter

By S. VAN MIERLO AND P. GLOESS

Les Laboratoires Le Matériel Téléphonique, Paris, France

General

AFTER preliminary work on television pick-up equipments, a complete system for ultra-short wave transmission and reception of film pictures was prepared in 1935 by Les Laboratoires Le Matériel Téléphonique, Paris. A series of tests was made between Avenue de Breteuil and Champs-Élysées and the results were comparable to those obtained elsewhere in Europe at the time. The television transmitter used an arc lamp and a scanning disc.

In view of further studies in connection with television problems, and particularly the development of terminal equipment and amplifiers for transmitting television signals through cables, it was decided to build a new laboratory film scanner having the following characteristics:

- (1) Easy operation and maintenance,
- (2) Number of scanning lines to be easily adjustable from 180 to more than 400 lines.

In order to satisfy the first requirement, the use of an arc lamp as light source was excluded. With such a lamp, it is very difficult to obtain a steady illumination and the time required for maintaining the equipment in proper adjustment, etc., is relatively great.

The second requirement eliminated the use of a scanning disc which would involve changing the disc when passing from one number of lines to another.

The simplest and probably the most satisfactory solution was to give a continuously vertical movement to the film and to scan it horizontally by means of the image of the spot produced on the screen of a cathode ray tube. The more complicated tubes used lately for television pick-up are not so interesting for film scanners.

The light, modulated by the film, is directed into a photoelectric cell.

The complete scanner, with most of the covers

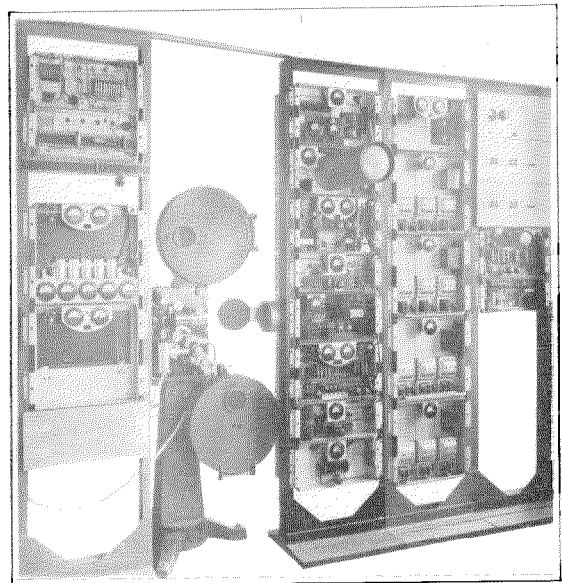

Fig. 1—Complete Scanner.

removed from the panels, is illustrated in Fig. 1. A short description of the different parts is given below. Fig. 2 shows the general circuit arrangement.

Frequency Generator

For a given number of scanning lines, it is necessary to have available a corresponding frequency for the production of synchronisation signals which control the movement of the spots, both of the scanning cathode ray tube and of the distant receiving tubes.

These frequencies must be multiples of the main current frequency so that any pattern visible on the receivers, as a result of incomplete filtering, has a fixed position on the screen. In case of non-synchronisation, a "hum" pattern would travel slowly across the image and cause a very disagreeable visual impression.

A group of panels is provided for obtaining multiples of the fundamental frequency, the following frequencies having been considered more especially: 4,500, 5,625, 6,000, and 10,125

cycles per second. A large number of other frequencies can be obtained if required.

Synchronisation Signal Generator

The sinusoidal currents of the generators are transformed by a series of circuits into a succession of very short impulses. These are used to control the relaxation oscillator of the scanning cathode ray tube and are also sent to a mixing panel described below. The methods used are such that extreme stability is obtained. A cathode ray tube is provided to check the shape of the synchronising signals and, in general, to control the operation of the above equipment.

Scanning Cathode Ray Tube

This is a very special cathode ray tube, fulfilling the following conditions:

- (1) Very brilliant and small spot,
- (2) Afterglow of less than 1 microsecond,
- (3) Uniform screen,
- (4) Reasonable life.

It is well known that all screen materials do not only produce light during the time they are bombarded by electrons, but remain luminescent some time after. The first effect is usually fluorescence, the second phosphorescence. This afterglow should be of very short duration in the present case; for, otherwise, the horizontal definition would be insufficient, several picture elements being illuminated simultaneously. It is difficult to reduce this time to less than 1 microsecond but, fortunately, it is possible to improve conditions by making use of the fact that the wavelength of maximum amplitude of the afterglow (some 6,000 Angström) is different from that of the first glow (some 5,400 Angström). It is therefore possible to eliminate to some extent the effect of the afterglow by using a filter or else a photo-cell which is much less sensitive to the afterglow.

There is no doubt that cathode ray tube technique can be greatly improved and that, in the future, very satisfactory tubes even for the highest definitions will become available.

In order to produce sufficient light, anode tension must be rather high: 6,000 volts have been used thus far in these Laboratories. Decreased illumination, which tends to increase the

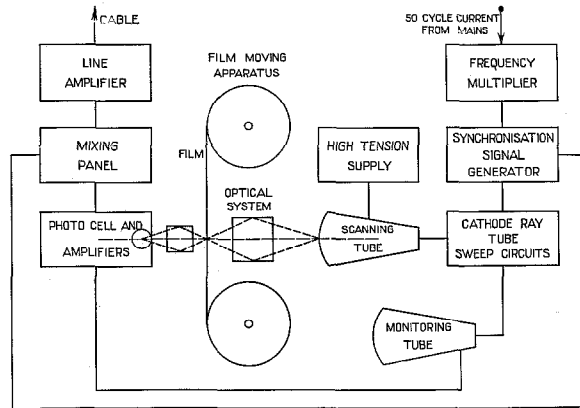

Fig. 2—General Circuit Arrangement of Scanner.

life of the tube, apparently results partially from decreased cathode emission and partially from the aging of the screen. Decrease in cathode emission can be avoided practically. To increase screen life the spot is not moved along a single horizontal line, but scans a surface of adjustable height, thus also avoiding a light saturation effect in the screen. A small portion of the pictures or of the intervals between pictures is lost by this method but this is inconsequential in practice.

The circuits are arranged also for scanning the film when at rest.

The sweep circuits are carefully designed to produce a very uniform scanning.

A monitoring cathode ray tube, operated with the same circuit as the scanning tube, is arranged to receive the picture signals and so to reproduce the picture. The effect of any adjustment, therefore, can be controlled immediately by the operator.

Film Moving Apparatus and Optical Systems

A special and compact unit has been developed for moving the film vertically in a very uniform way. A sound head is provided and a high grade optical system is used to project the scanning spot on the film with little loss of light and definition.

Photo-cell and Amplifiers

The amount of light passing the transparent parts of the film is extremely small (for instance,

less than 10^{-3} lumen for a definition corresponding to 240 lines) and an amplification of more than 100 db. is needed to obtain normal signals. Electron multipliers of special design can solve the problem but, since they were not available in time, it was necessary to develop an amplifier using vacuum tubes.

As previously mentioned, the photo-cell must have a special sensitivity curve adapted to the spectrum of the scanning ray tube. Unfortunately, cells having the required maximum of sensitivity are not very efficient, as a current of only about 10 microamperes is obtained per lumen. Doubtless, improvement can also be expected in this direction.

One of the difficulties in the design of the amplifier is the wide frequency band, commencing at some 10 cycles per second and extending to some 2 megacycles per second. It is sometimes considered easier not to amplify this band as it is, but to use a carrier modulated by the signals. To take full advantage of this method, it would be necessary to use a rather high frequency for the carrier and it then becomes very difficult to handle the signals. The modulation process, furthermore, must be applied carefully to avoid intermodulation. The modulation method, therefore, presents serious difficulties and it was decided to use, tentatively at least, a straight amplification of the normal frequency band.

The main problem in the amplifier, however, is that of noise. In addition to noise due to mechanical vibration and to interference from outside, it is well known that, with small input levels, the noise due to thermal agitation in the resistances and to various causes in the tubes becomes comparatively important. Tubes must therefore be chosen carefully or be made specially to reduce shot and flicker noise and to avoid ionisation and secondary emission.¹

The noise due to thermal agitation can be cut down by choosing certain circuit conditions. The following calculation gives in a simple way a guide for the choice of the circuit elements.

The simplified circuit of Fig. 3 shows the coupling between a photo-cell and a vacuum tube. I is the current in the photo-cell, R the

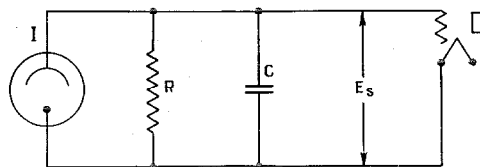

Fig. 3—Simplified Circuit showing Coupling between a Photo Cell and a Vacuum Tube.

combined resistance of a resistor and the insulation of the photo-cell and tube, C the combined capacity of the photo-cell, the resistor, the tube, and the wiring. The value of the signal potential difference E_s at the input of the tube is $I \times Z$ when Z is the impedance of R and C in parallel. We have, therefore:

$$E_s = \frac{IR}{\sqrt{1 + \omega^2 R^2 C^2}}$$

The potential difference of the thermal agitation noise at the input of the tube for a frequency band equal to 1 is

$$E_T = 2\sqrt{kTr}$$

as shown in an article in the *Physical Review*,² where k is the Boltzmann constant, T the absolute temperature, and r the resistive component of the combination of R and C in parallel. It is very important to note that it is not R , but r which is to be used in this formula.

We find finally that the ratio signal to noise is equal to

$$\frac{E_s}{E_T} = \frac{I}{2} \sqrt{\frac{R}{kT}}$$

Since k cannot be controlled, changes in T are of little help. It will therefore be seen that besides increasing I as much as possible, the resistance R should also be increased. The high frequencies will then be attenuated much more than the low frequencies, but a correction can be made later.

The upper limit of this resistance is determined partially by the fact that it is not advisable to reach values corresponding to the insulation resistances and the leakage resistance corresponding to the grid current of the tube unless these are maintained very stable, and partially by the consideration that there is no reason to increase the resistance further when the thermal

¹ "Fluctuation Noise in Vacuum Tubes," by G. L. Pearson, *Bell System Technical Journal*, October, 1934.

² "Thermal Agitation of Electric Charge in Conductors," by H. Nyquist, *Physical Review*, July, 1928.

agitation noise becomes of the same order as the tube noises.

These considerations led to the use of a photo-cell resistor of unusually high resistance (50 megohms).

The unavoidable thermal noise in the plate circuit can be reduced by employing small plate tensions and large outside resistances. Elimination of noise due to extraneous causes requires mechanical and electrical filtering.

Fig. 4 shows the circuit of one of the amplifiers used during the development period. Without special precautions, the use of a very high input resistance would cause overloading of tubes at low frequencies. In the present case, the amplitude distortion due to this input circuit is corrected partially by the plate circuit of the first tube. L_a and R_a are chosen in such a way that the signal-to-noise ratio is not decreased appreciably. A resistance R_c is placed in the cathode circuit of the first tube, which is a high frequency pentode and which, by negative feedback, decreases somewhat the noise due to its anode current. The voltage drop in this resistance is also used to obtain the required potential at the control grid.

As the impedance of the anode circuit is very small at the low frequencies, the anode battery and filtering circuit is not included in the coupling circuit. The battery is used also to polarise the photo-cell.

The only special feature of the second stage is the very high resistance value of the anode

resistor. The third stage provides a further correction of the amplitude distortion, and is very similar to the first. The fourth stage is arranged to adapt the amplifier to a short coaxial cable leading to a second amplifier.

Mixing Panel and Line Amplifier

The amplified television signals and the synchronisation signals can be mixed together in various proportions as required.

As signals will usually be transmitted over a certain length of cable having an impedance of the order of 70 ohms, a line amplifier is provided in order to obtain a sufficient voltage at this low impedance.

Switching and Safety Arrangements

By means of switches it is possible to change from one type of scanning to another.

Relays are provided in order to avoid the high tension being applied on some circuits before cathodes have heated up sufficiently. It is, therefore, possible to start the transmitter by simply pressing a button.

These arrangements also aid in making the operation easy and in reducing maintenance. It has been found that one operator is amply sufficient to take care of everything, including the handling of the films, while two men are needed to give satisfactory service with an apparatus using arc lamp and scanning disc.

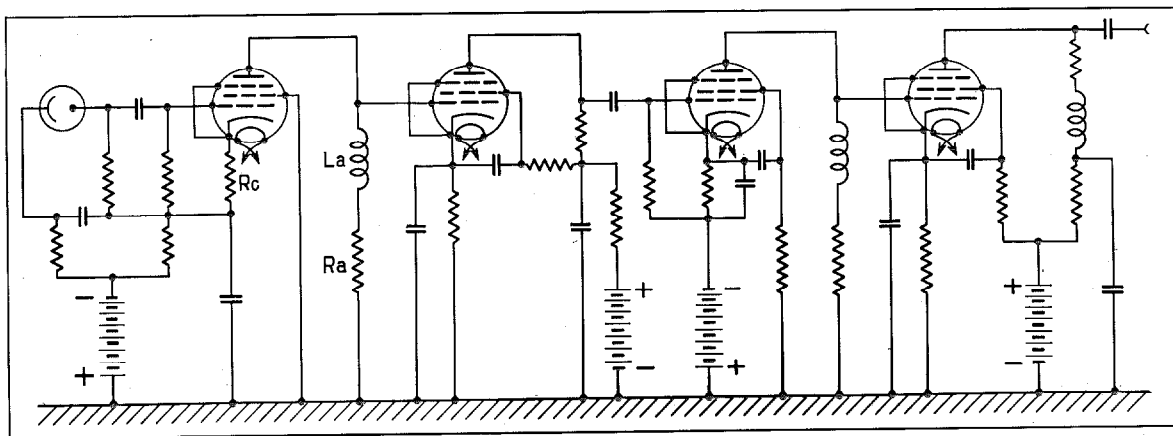

Fig. 4—Circuit of an Amplifier used during Development Period.

An Experimental Television Receiver

By S. VAN MIERLO and C. A. PULLES

Les Laboratoires Le Matériel Téléphonique, Paris, France

General

THE first models of television receivers developed for testing purposes during 1935 yielded information for the construction of a new receiver. The plan was to arrange it for the reception of 180 line pictures transmitted from the Eiffel Tower and also for 240 and 405 line pictures transmitted by Les Laboratoires Le Matériel Téléphonique equipment.

Fig. 1 shows a rear view of the television receiver. The equipment comprises three units: one unit is an ordinary audio receiver; the second is a broad band short wave visual receiver; and the third includes the deflecting circuit which moves the spot on the screen of the cathode ray tube and the power supply for the cathode ray tube.

A separate audio receiver is provided for the reason that audio signals are transmitted from the Eiffel Tower on a wavelength of 206.0 or 431.7 meters, while television signals are sent out on an ultra-short wave transmitter.

Visual Receiver

The broad band visual receiver operating on 6 to 10 meter wavelengths is a superheterodyne receiver with three intermediate frequency stages, a diode-triode detector-amplifier, and one "low" frequency amplifier stage, at the output of which the modulating grid of the cathode ray tube is connected, as well as a circuit for separating the television signals from the synchronisation signals.

As at present developed, a frequency band of more than 1 megacycle per second can be passed.

Separating Circuit

Fig. 2 shows how the modulating grid of the cathode ray tube and the separating circuit are connected to the plate circuit of the low frequency amplifier stage.

The grid of the separating tube has a positive bias so that the television signals have no influence on the plate current. The synchronisation

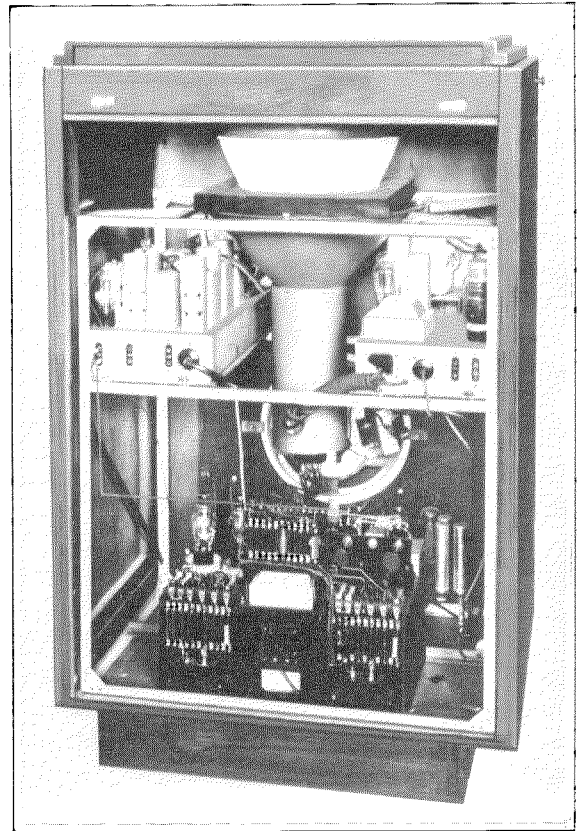

Fig. 1—Television Receiver—Rear View.

signals, however, are sufficiently strong to cause a negative tension on the grid and, consequently, a positive peak at the plate of the separating tube.

When individual horizontal and vertical synchronisation impulses are given, the horizontal impulses are very much shorter than the vertical ones. It is thus possible to separate these impulses by means of the resistances R_s and the condensers C_s .

Deflecting Circuit

The deflecting circuit works on the well known principle of charging a condenser through a high resistance and applying the continuously rising potential of the condenser to the deflecting plates of the cathode ray tube. For obtaining a nearly

steady increase in this potential and, therefore, a nearly uniform deflection of the spot, two methods are generally used. In one case the condenser is charged through a vacuum tube, giving constant charging current. In the other case, small potential variations are first produced and then amplified. Both methods require additional tubes or apparatus.

The Laboratories circuit uses simple charging resistances, but charges the condensers from the full 4,000 volt anode voltage of the cathode ray tube. Since these condensers merely require charging up to about 500 volts, only the nearly straight part of the charging potential curve is used. The net result is a reduction in the number of tubes and a simplification in the high tension supply.

Fig. 3 shows a schematic arrangement of the charging and discharging circuit, in which the condensers C are charged through resistances R and the gas filled discharging tubes GDT . The separating condensers C_s give the deflecting plates D the required average potential.

A balanced deflecting circuit is used to obtain a rectangular pattern on the high vacuum

cathode ray tubes.

Gas discharge tubes of good quality have given satisfactory results, at least with 240 lines.

Fig. 2 includes the complete circuit for horizontal and vertical deflection, the power supply circuit and the connection of the cathode ray tube. The condensers C_1 , C_2 , C_3 , and C_4 are charged by the 4,000 volt source through resistances. Depending upon the grid tensions, the gas discharge tubes GDT_1 , etc., break down at a certain tension, thus discharging the condensers through 1,000 ohm protecting resistances. When no synchronisation impulses are given, these discharges happen at somewhat irregular intervals. When, however, synchronisation is applied, the charging and the biasing resistances can be adjusted so that these synchronisation impulses control the operation of the gas discharge tubes.

The discharge of C_1 , in the vertical deflecting circuit, causes a positive potential at the cathode of GDT_1 . This potential is applied through a condenser to the grid of GDT_2 , thus causing the breakdown of the latter tube and the discharge of C_2 .

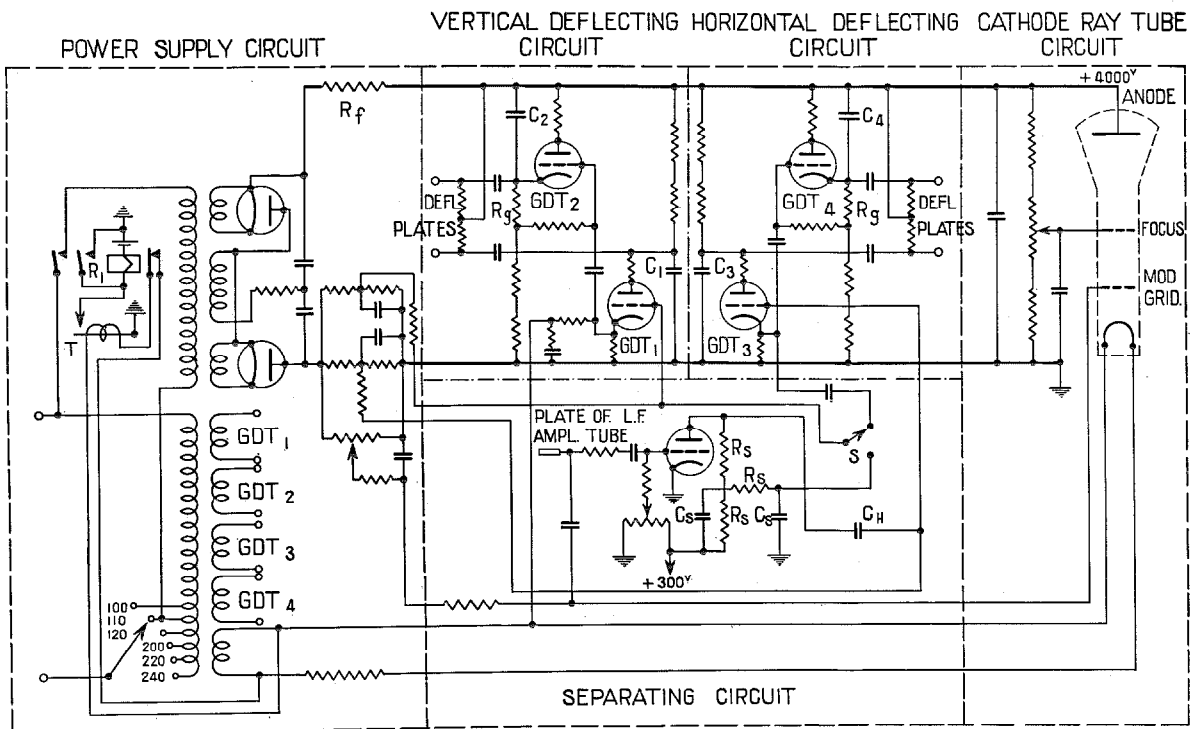

Fig. 2.

The operation of the horizontal deflecting circuit is similar to that of the vertical deflecting circuit. The condensers and resistances are, however, different.

The filament of the cathode ray tube is connected to the filament of GDT_1 in order to obtain a high negative tension on its grid at the moment GDT_1 discharges; that is, at the moment when the spot of the cathode ray tube returns from

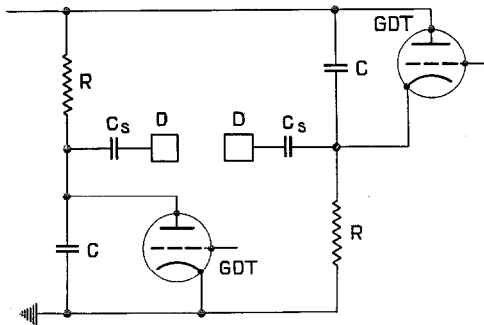

Fig. 3.

the bottom to the top of the screen. This negative grid tension avoids a visible return crossing the picture.

To provide for both 180 line and 240 line working, the condensers C_3 and C_4 each consist of two condensers in series, the smaller of which is short-circuited for 180 line reception, while the larger is short-circuited for 240 line reception. For 405 line reception, both condensers are used in series. The switch for making the necessary short-circuits is coupled with a switch, S , which is used for passing from one system of vertical synchronisation to another. The vertical synchronisation of the Eiffel Tower emission is obtained by the suppression of the 180th vertical synchronisation signal. Therefore, the charge of C_3 becomes greater than normal and, when GDT_3 discharges its condenser, a higher potential is obtained at the cathode resistance. This higher potential is applied through a condenser to the grid of GDT_1 which breaks down at this potential, thus causing the vertical return of the spot.

When switching over to 240 or 405 line working for the reception of the Laboratories transmission, which utilises a separate vertical synchron-

isation impulse, the grid of GDT_1 is connected to the separating circuit in which the vertical synchronisation impulse is separated from the horizontal synchronisation as above described.

Power Supply Circuit for the Cathode Ray Tube and for the Deflecting Circuit

The cathode ray tube used in the set works with an anode tension of 4,000 volts. This tension, which is used also for the deflecting circuit, is obtained by means of the voltage doubler circuit shown in the power supply circuit of Fig. 2.

A separate transformer is used for the filaments of the gas discharge tubes and of the cathode ray tube. As the cathodes of the gas discharge tubes must be hot before applying the high tension, the high tension transformer is connected to the mains about half a minute after connecting the filament transformer. This is accomplished by means of a thermic relay T , the winding of which is heated by the filament transformer. T , in closing its contact, causes the operation of the relay R_1 , the winding of which is connected to the grid supply of the visual receiver. R_1 connects the primary of the high tension transformer to the mains, closes a holding circuit for itself, and opens the heating winding of the thermic relay.

In the positive lead, a resistance R_f is introduced for filtering and for adjusting the high tension to the desired value. In the negative lead, a group of resistances is used for obtaining the necessary negative grid tensions for GDT_1 and GDT_2 , and for the cathode ray tube.

The grid bias of GDT_2 and GDT_4 is obtained by means of resistances R_g in series with the charging resistances.

Results Obtained

Receivers of the type described have been used in the Laboratories and for several demonstrations with quite satisfactory results. With a field strength very considerably below 1 mV /meter, very stable pictures have been obtained. It is important that the antenna, which may be of the doublet or "Zep" type, be placed at a height appropriate for obtaining the required field strength as well as for protection against outside interference, such as from motor cars.

Power Plants for Rural Full Automatic Offices

By V. C. MEEUWS,

Bell Telephone Manufacturing Company, Antwerp, Belgium,

and H. B. LEE,

Standard Telephones and Cables, Limited, London, England

1. Introduction

THE advent of the unattended rural automatic exchange has brought with it the necessity for an automatically operated power plant. The reliability of the automatic switching equipment now being used in these small and medium sized offices is such that the associated power plant must be capable of operating satisfactorily for long periods without manual attention.

In a large exchange, the cost of the additional apparatus required for automatic working is small compared with the total cost of the plant, whilst skilled mechanics are immediately available for maintenance purposes. In the case of a rural office, where the outlay on the power plant has to remain more or less in proportion to the number of lines installed, the cost of the additional equipment necessary for automatic operation is a matter which must receive careful consideration. It is also essential that the automatic power apparatus be simple, reliable, and easily adjustable, since, at the rural exchange, skilled attendants are not immediately available.

Several types of the Bell Telephone Manufacturing Company's automatic power plants are in successful operation. In general, these equipments may be divided into two principal classes: the duplicate battery plant and the single battery plant, both including the usual motor generator sets or rectifiers.

The duplicate battery system is becoming more and more restricted to those areas where, during certain hours of the day, the electrical supply is available at a reduced rate. The single battery system, with sufficient battery capacity to maintain the service during a period of power failure, is becoming increasingly popular, both on account of its lower initial cost and its higher efficiency, particularly when operating on a full float basis.

2. General Requirements for Power Plants in 7-D Rotary Offices

Reliable operation of automatic exchanges is only guaranteed when the voltage of the feeding current is kept within certain limits. For rural exchanges, the following limits are fixed:

7-D center type exchange—minimum 44, maximum 52 volts;

7-D district exchanges—minimum 44, maximum 54 volts.

The above limits are to be taken as applying at the circuit fuses of the automatic switching equipment. For small exchanges where there is, as a rule, practically no distance between the battery, the power board, and the circuit fuses, the minimum battery voltage may correspond to the minimum limit fixed for the operation of the equipment. For medium and large sized offices, the minimum permissible limit at the discharge fuses on the power board must be kept above the minimum equipment limit by the amount of voltage drop allowed in the discharge feeders. This drop is fixed at 2 volts when the feeders carry current used for signaling purposes only, or for talking and signaling combined, where the microphones are fed over retardation coils. For talking circuits using repeating coil transmission the permissible drop is limited to 0.5 volt.

During discharge the voltage of the lead-acid battery falls from 2 to approximately 1.83 volts per cell, and the minimum number of cells required in a battery is therefore fixed at:

$$\left. \begin{array}{l} \frac{48}{1.83} = 26 \text{ cells} \\ \frac{46}{1.83} = 25 \text{ cells} \\ \frac{44}{1.83} = 24 \text{ cells} \end{array} \right\} \begin{array}{l} 48 \text{ volts} \\ \text{For exchanges where} \\ \text{the voltage should} \\ \text{not drop below} \\ 46 \text{ volts} \\ 44 \text{ volts} \end{array}$$

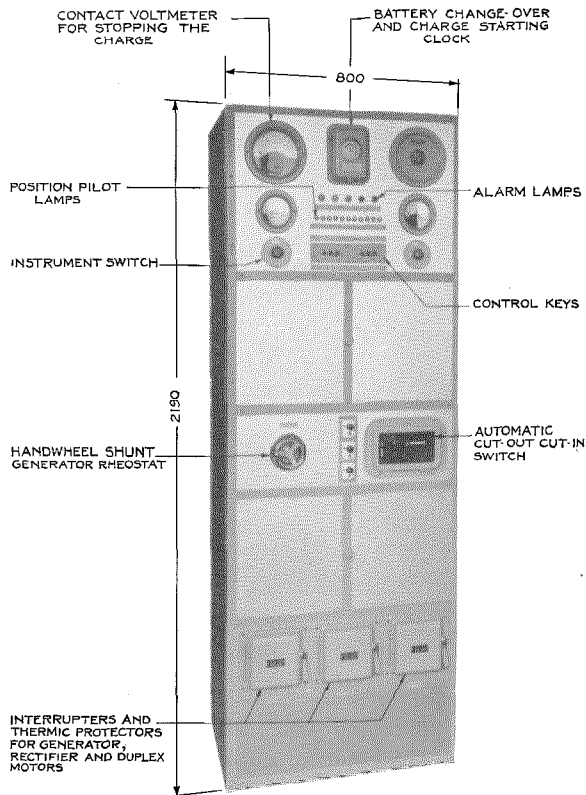

Fig. 1—All Metal Powerboard.

The voltage of these batteries when charged in the normal manner rises to 65, 67.5, or even 70.2 volts. Unless, therefore, some form of voltage regulation is provided, the battery must be disconnected from the load whilst charging, thus necessitating a duplicate battery arrangement.

3. Duplicate Battery Arrangement

The duplicate battery arrangement requires two batteries, one of which is charged, whilst the other is discharged. The charging generators or rectifiers need not be of the telephone type for this service.

Duplicate battery systems are used with semi-automatic and with full automatic operation. Plants which are entirely manually operated are of no use in automatic rural offices.

With semi-automatic operation, the batteries are changed over and the charging plant is started by the attendant. On the completion of the charge, as indicated by a contact voltmeter

or an ampere hour meter, the charging generator or rectifier is automatically disconnected. With full automatic operation, the changeover of the batteries can be controlled by the voltage of the battery feeding the equipment. This voltage, however, depends on the rate of discharge at any particular moment, so that it is preferable to interchange the batteries after a predetermined number of hours of service. Provision is made for placing the used battery on charge as soon as it is disconnected from the exchange.

Figs. 1 and 2 show an all metal power board designed for a full automatic, duplicate battery arrangement, operated on the charge-discharge principle. The board is designed for a maximum discharge current of 100 amperes. The two batteries are interchanged at a predetermined time under the control of an electrically wound clock, which also starts the charging generator and connects it to the discharged battery. The charge is terminated by the operation of a contact voltmeter, set to close at the maximum voltage which should be reached with the battery fully charged.

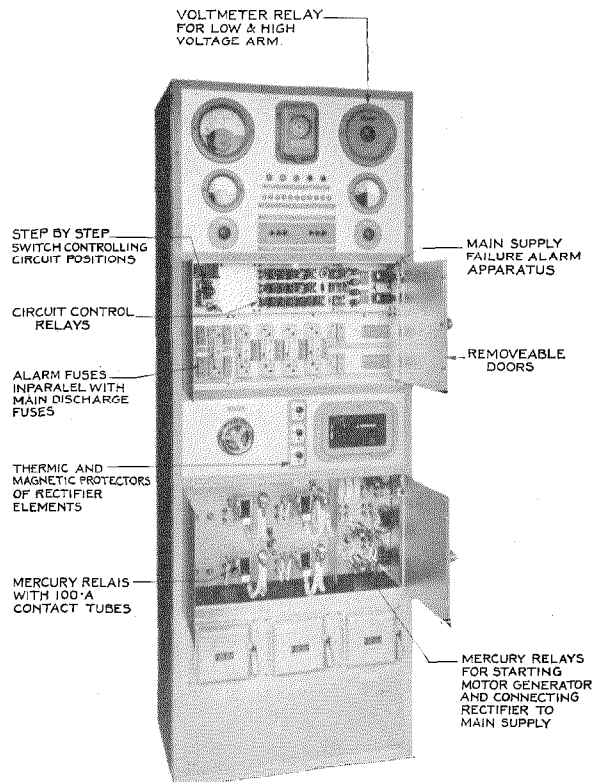

Fig. 2—All Metal Powerboard (Doors Open).

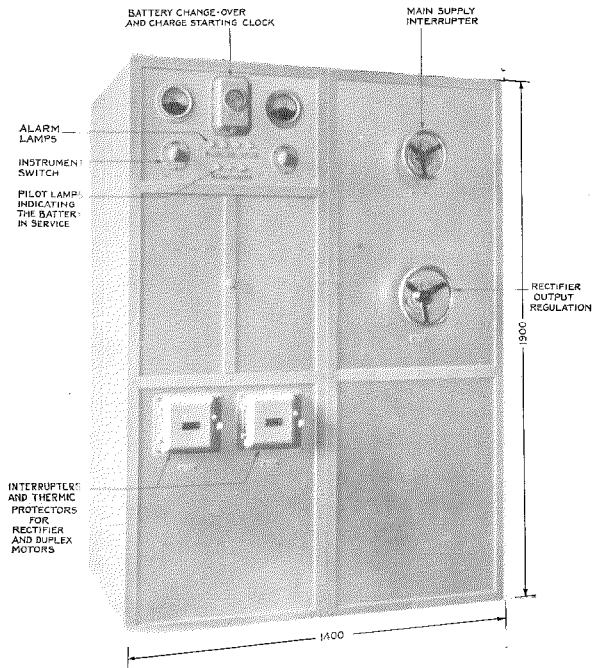

Fig. 3—Another Type of Automatic Duplicate Battery Arrangement.

When desired, during the day the battery which is being discharged may be floated by means of a Selenium rectifier. By operating appropriate keys the batteries may be interchanged manually, connected in parallel for emergency discharge, or floated in parallel. The arrangement is such as to prevent incorrect operation, whilst the pilot lamps are fitted to indicate the particular circuit condition which exists.

Another type of automatic duplicate battery arrangement is shown in Figs. 3 and 4. In this case the charging current is supplied by a 40 ampere hot cathode rectifier. The changeover is again controlled by an electric clock, but, in addition, provision is made such that, should the voltage of the discharging battery fall too low, the changeover would operate and the discharged battery would immediately be put on charge.

4. Single Battery Arrangement

4.1 GENERAL CONSIDERATION

As mentioned previously, the voltage of a lead-acid battery rises to 2.7 volts per cell when charged in the normal manner. This does not mean that a battery cannot be fully charged

without reaching this voltage. The voltage of a cell towards the completion of the charge is a function of the charging current. Provided the charging rate is sufficiently reduced and the charging time increased to correspond, a battery may be fully charged without the voltage exceeding 2.4 volts per cell, but it takes about 160 hours to complete the charge if a current of constant value is used.

Referring in particular to the Belgian Tudor Planté cell, Fig. 5 shows the capacity at various discharge rates; and, for the different charging rates, the state of charge of Planté type cells when the tension reaches 2.16, 2.2, 2.25, 2.3, and 2.4 volts. The curves are taken at 15° C. with an electrolyte of specific gravity 1.200 (24° Baumé) when fully charged. The cells used were fitted with wooden separators.

The different equipment requirements and battery characteristics for 7-D office power plants are as follows:

	Center Type Exchange	District Type Exchange
(a) Maximum voltage	52 volts	54 volts
(b) Minimum voltage at circuit fuses.	44 volts	44 volts
(c) Minimum number of cells if drop in feeders can be neglected.	24 cells	24 cells
(d) Minimum number of cells if 2 V. drop in the feeders is to be considered	25 cells	25 cells
(e) Maximum permissible tension per cell with a 24 cell battery when no C.E.M.F. cells are connected in the discharge.	2.16 V.	2.25 V.
Same with 25 cells	2.08 V.	2.16 V.
(f) Approximate percentage of full charge capacity which can be restored to a battery without exceeding the maximum tension per cell with the intensity of the charging current reduced to a 10 hour value—24 cell battery	49%	71%
(g) Same for 25 cell battery	—	49%
(h) Same for 24 cell battery with charging current reduced to 20 hours value	61%	78%
(i) Same for 25 cell battery with charging current reduced to 20 hour value	—	61%

The above tabulation shows that the battery in 7-D rural exchanges cannot be charged 100% without exceeding the voltage limits, even when these are as wide as 44–54 volts, if a recharge of the battery is desired within 20 hours after a full discharge.

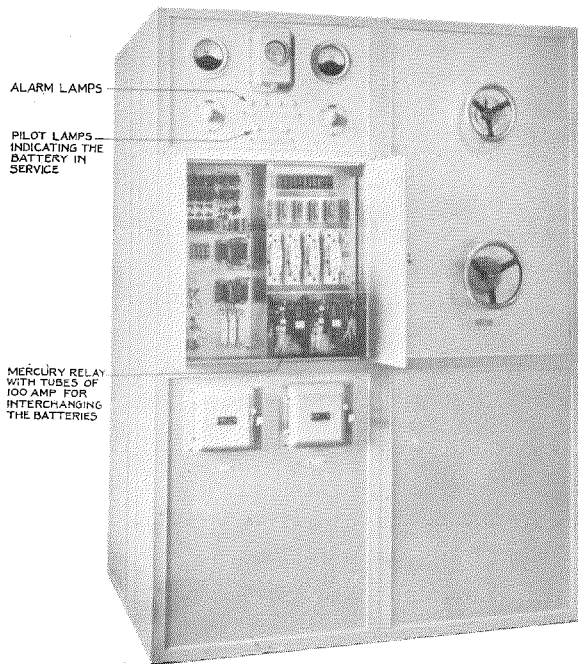

Fig. 4—Another Type of Automatic Duplicate Battery Arrangement.

The simplest method of feeding an exchange by means of a single battery is to employ a battery of large size, such that when charged to only about three-quarters of its full capacity, there is sufficient reserve to feed the equipment during power failures. This arrangement may be used either with or without controlled charge.

With controlled charge, a voltage relay cuts off the charge when the battery voltage reaches the upper limit and reconnects the charging supply when the voltage has dropped to about 2 volts per cell. Alternatively, the charge may be controlled by means of a double wound choke coil, one winding of which is connected in the primary supply to the charging rectifier, whilst the second winding carries the d-c. output. This automatic choke-controlled rectifier is described in more detail later, but it must be pointed out here that the output of such a rectifier is affected to a considerable extent by the voltage variations of the main supply.

With uncontrolled charge, the charging current is adjusted so that the input to the battery over a given period corresponds to the average current requirements of the exchange plus the losses in the battery.

In practice the uncontrolled charge consists in floating the battery with a current of a value such that the voltage is maintained between 2.18 and 2.3 volts per cell, depending on the temperature and the type of plates used. In rural offices, where the tension of the main supply is as a rule unstable and power failure much more frequent than in larger centers, the regulation of such a plant presents many difficulties.

4.2 RECTIFIER OPERATED SINGLE BATTERY FULL FLOAT PLANTS

In district exchanges there are usually several hours per day when there is practically no traffic. It is, therefore, possible to charge the battery up to the 54 volt limit and to continue beyond this point provided arrangements are made to suspend charging temporarily whilst a call is in progress. Immediately the charge is stopped the voltage falls within the required limits and, when the call is terminated, the charging current can be reestablished.

When the charging is adjusted to a 10 hour rate value, about 71% of the full charge capacity can be restored to the battery in district offices before the 54 volt limit is reached. Beyond this point the charge should be continued with the current reduced to a trickle charge value in order to avoid over-formation of the positive plates.

A system making use of the above principles has been found to give excellent results in small 7-D offices. The method of operation, prepared in bulletin form by the Bell Telephone Manufacturing Company, Antwerp, on the 7-D Rotary Automatic Telephone System, may be summarised as follows:

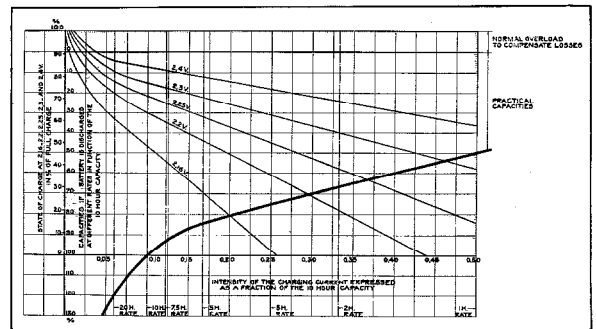

Fig. 5—Capacity at Various Discharge Rates of Tudor Planté Cell.

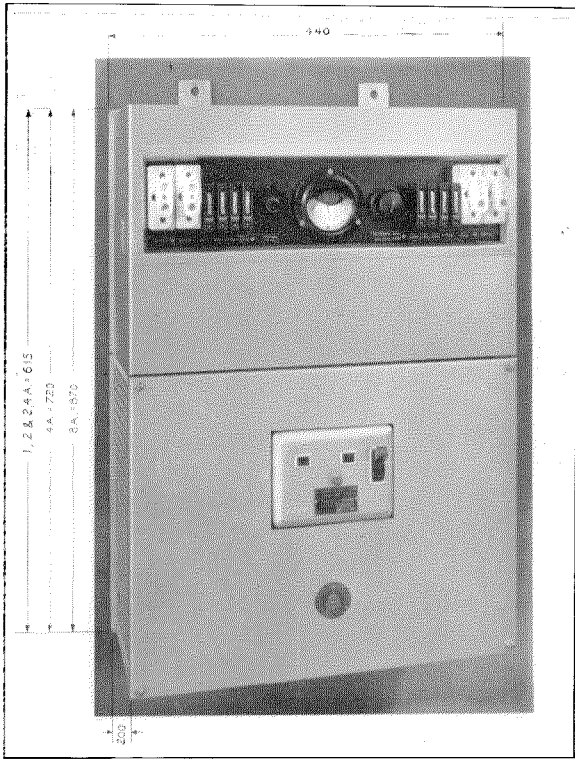

Fig. 6—Antwerp Power Units.

Direct current, with a sufficiently low ripple, is obtained from a Selenium rectifier provided with smoothing choke and dry electrolytic condensers. This current is fed via two adjustable resistances, one resistance regulating the normal charging current and the other, the trickle charge. The main charge is controlled by voltage relays arranged so that this circuit is interrupted only when the voltage rises to 54 and is reestablished when it falls to 50 volts. Calls going through the exchange open the trickle charge circuit but not the main circuit. The arrangement therefore permits the rectifier to deliver current at the full rate until the voltage limit is reached. Beyond this point, the charge is continued at the trickle charge rate when no calls are in progress. An alarm is arranged to operate when the main supply is interrupted, or when the voltage falls below a predetermined limit.

The relays may be mounted either with the automatic equipment or with the rectifier. The power units recently standardised by the Bell Telephone Manufacturing Company are arranged so that the rectifier with its overload

protection, the control relays, the combined volt and ammeter, together with the fuses, etc., are all contained in a single unit, as illustrated in Figs. 6 and 7. They show a rectifier built for outputs of 1.2, 2.4, 4.0, and 8.0 amperes at 44 volts. Fig. 8 shows the output curve of the 2.4 ampere rectifier.

4.3 FULL AUTOMATIC PLANTS WITH AMPERE HOUR METER CONTROL

A type of power plant which has been in satisfactory operation for many years, both in Europe and in the United States, and is being adopted by the British Post Office, is one which makes use of a special ampere hour meter connected in the battery lead. When the battery has been discharged some 10%, the ampere hour meter makes contact and starts the charging apparatus, which continues to supply current until the battery is again fully charged. This type

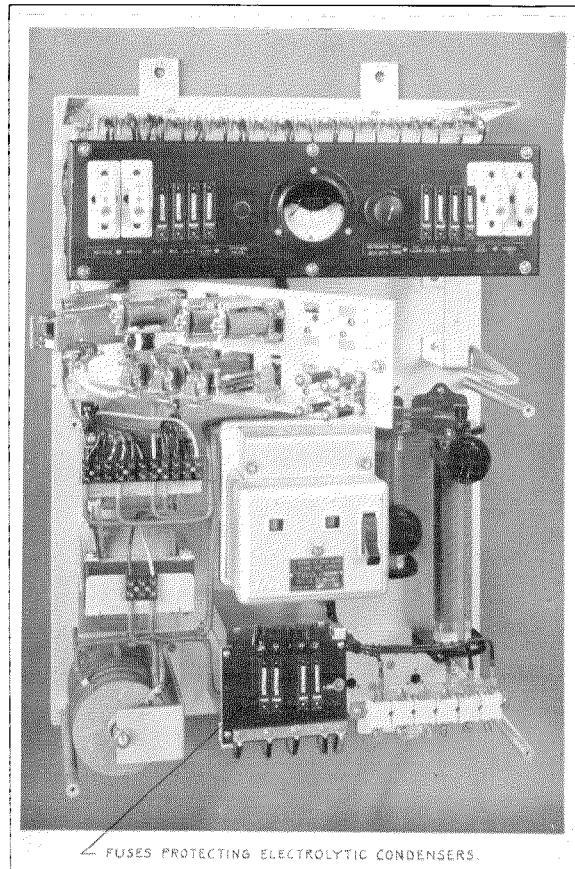

Fig. 7—Antwerp Power Units.

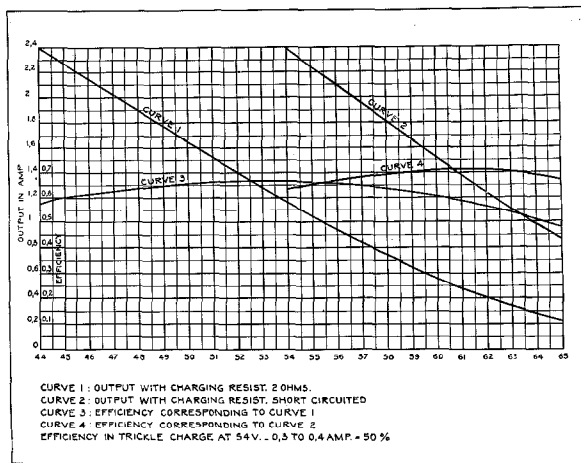

Fig. 8—Output Curve of 2.4 Ampere Rectifier.

of plant cannot, strictly speaking, be described as full floating in operation but, since the charging plant normally starts in the morning when the traffic is increasing, the greater portion of the load is supplied by the machine or rectifier and not by the battery. In addition to the contacts for stopping and starting the charge, a third contact gives an alarm when the battery is discharged more than 35%. The ampere hour meters used read correctly in the discharge direction but in the reverse, or charge direction, the reading is low by an amount which can be varied from 10% to about 40%, thus enabling the excess of charge over discharge to be adjusted to allow for the losses in the battery.

Figs. 9 and 10 illustrate a power board designed for a single battery plant with ampere hour meter control, the current being supplied by a Selenium rectifier. This type of board is suitable for exchanges with a maximum current drain of 100 amperes.

It is essential that the output of the rectifier be sufficient to make good, every 24 hours, the total drain to the exchange plus the losses in the battery but, in order to provide for the necessary reserve and quick recharge, it is usual to specify a rectifier having an output at least equal to the maximum drain.

In order that the battery may be charged to its full capacity, C.E.M.F. cells are connected in the discharge lead under the control of a contact voltmeter which also short-circuits these cells when charging ceases.

The same arrangement can be used when a charging generator is used in place of a rectifier, but in this case it is slightly more complicated. In addition to starting the motor, it is necessary to connect the generator to the battery as the voltage builds up, and to provide protection against current reversal.

In order to somewhat simplify the arrangements, a scheme has been developed which dispenses with the contact voltmeter or voltmeter relay by making use of a generator compounded to give a practically constant voltage from no load to full load ($\pm 3\%$ tolerance). When the generator is floating a battery, the series winding is not connected between the armature and the battery but is inserted in the discharge lead in order to prevent the possibility of a current reversal and to ensure that the increase in generator field flux is proportional to the current taken by the equipment, thus maintaining a constant voltage irrespective of the load.

In practice it is usual to arrange for only a portion of the load to pass through the series winding by connecting it in parallel with

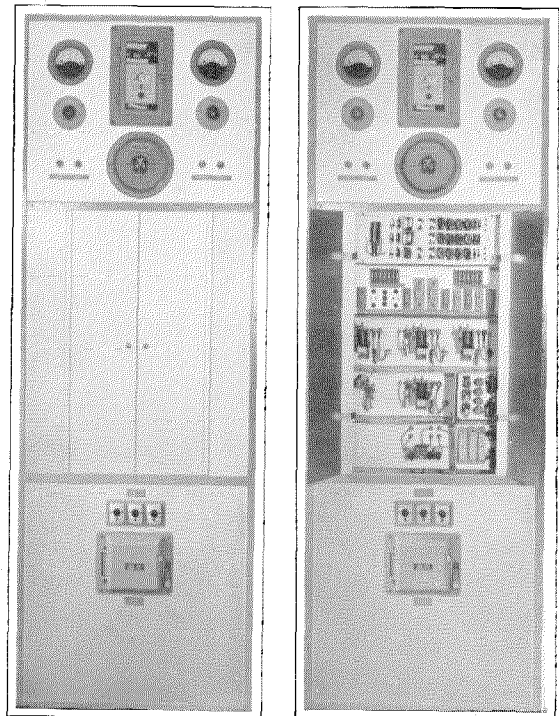
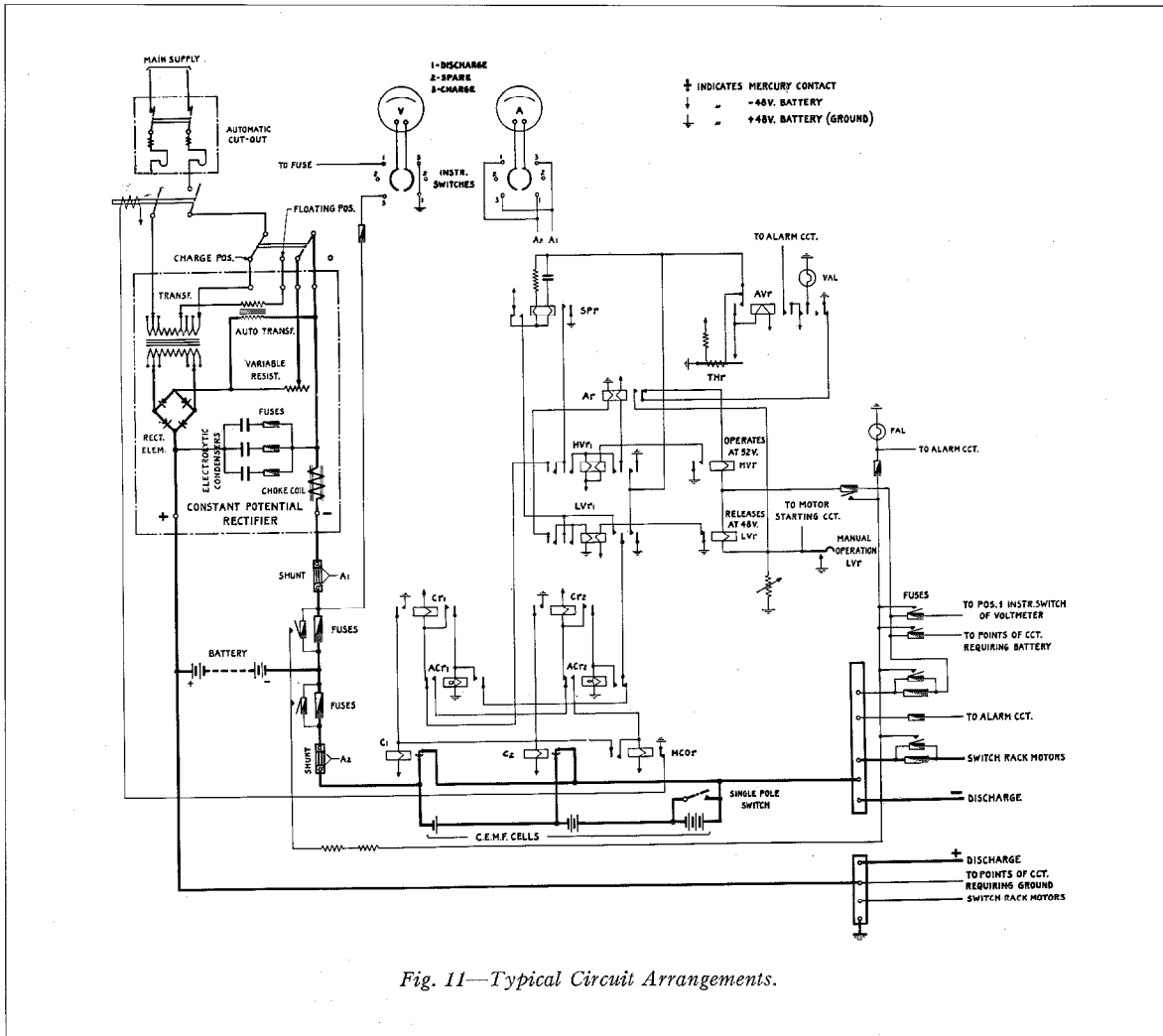

Fig. 9
 Fig. 10
 Power Board Designed for a Single Battery Plant with
 Ampere Hour Meter Control.
 (Left: Closed; Right: Open)



an adjustable non-inductive shunt. With this scheme, the ampere hour meter closes the circuit for starting the generator when the battery has been discharged 10%, just as in plants previously described. The generator is adjusted to give 2.25 volts per cell of the battery at an output corresponding to the drain of the equipment plus the losses in the battery. When the generator is connected to the battery, a C.E.M.F. cell is introduced simultaneously into the discharge lead, thus permitting the battery voltage of the 24 cell battery in center exchanges to be increased to 54 volts. When the current taken from the battery plus the losses has been restored the ampere hour meter stops the charge. Since with one C.E.M.F. cell the battery voltage is limited

to 2.25 volts per cell, the arrangement does not permit the battery to be fully charged. Where it is desired to charge the battery more fully, two C.E.M.F. cells must be introduced at the same time in order that the battery voltage may be increased to 56 or 2.33 volts per cell.

Such plants require a full charge up to 2.7 volts per cell about every two months. This is made possible by connecting C.E.M.F. cells in the discharge lead to the exchange.

4.4 FULL FLOAT PLANT WITH CONSTANT POTENTIAL RECTIFIER

The term "constant potential rectifier" is used to describe a rectifier constructed so that its

adjusted to cut off at 54 volts when the supply is 5% above normal will give practically no output at 50 or 51 volts when the main supply is 5% below normal.

To avoid the above mentioned difficulty, the constant potential rectifiers furnished in power plants of rural exchanges are preferably designed to cut off at 54 volts when operating on the minimum supply voltage, thus ensuring that the battery will be adequately charged under all conditions. In order that the exchange voltage

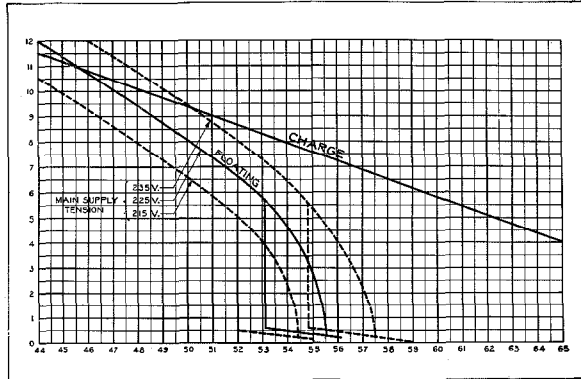

Fig. 14—Output Curve of Power Plant of Fig. 13.

may not be excessive when the mains voltage is high, and to enable the battery to be charged to its full capacity, provision is made for the automatic introduction of C.E.M.F. cells into the discharge lead under voltage operated control. Provision is also made for adjusting the trickle charge current by shunting the d-c. winding of the choke coil with an adjustable non-inductive resistance, whilst in order to facilitate the first charge and to permit of a specially quick recharge after a prolonged power failure, it is possible to render the constant potential feature entirely non-operative.

Two of the typical circuit arrangements are shown in Figs. 11 and 12. In one case (Fig. 11) the introduction of C.E.M.F. cells is controlled by voltage relays of the telephone relay type. In the other case (Fig. 12) the C.E.M.F. cells are under the control of a contact voltmeter or voltmeter relay. The former circuit is used for the smaller, and the latter circuit for the larger plants. Both schemes are reliable, but whilst the contact voltmeter is easier to adjust and more accurate than the voltage relay, its greater cost is a serious matter in the smaller plants. Moreover, since great accuracy is not essential, it is possible that the voltage relay system may eventually be employed, irrespective of the size of the equipment.

In both circuits the C.E.M.F. cells are introduced in successive stages, and when all the cells are in circuit and the exchange voltage again reaches the upper limit, the rectifier is disconnected from the supply, to be reconnected only when the exchange load has caused the voltage to fall to a predetermined limit. Both circuits make

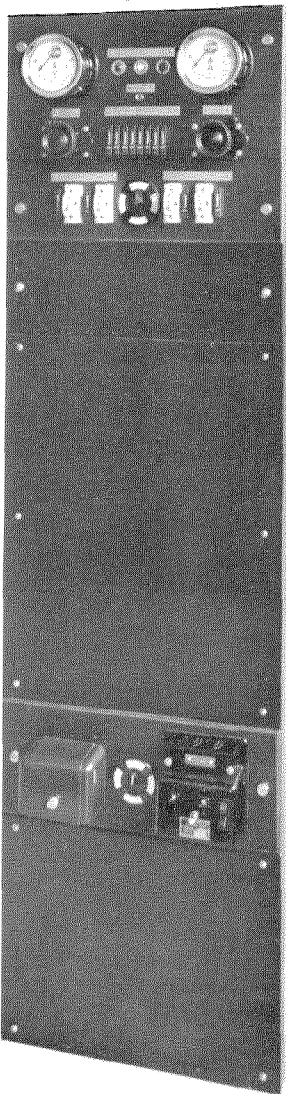

Fig. 13—Power Plant with a Circuit in Accordance with Fig. 11.

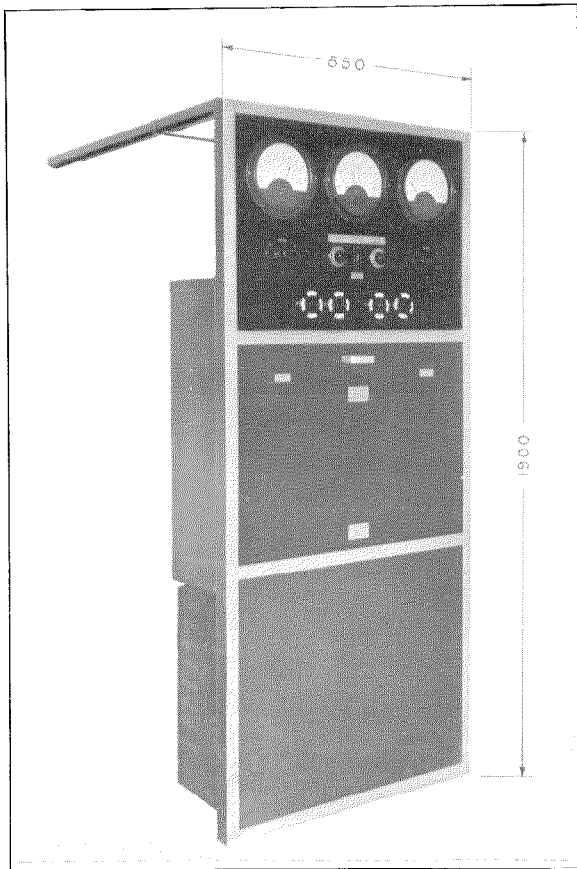

Fig. 15—Power Plant with a Circuit in Accordance with Fig. 12.

provision for cutting out the constant potential choke for the purpose of initial charge, or quick recharge, and terminals are also provided for connecting additional C.E.M.F. cells to enable the battery to be charged to 2.7 volts per cell on occasion. These additional C.E.M.F. cells are usually of the portable type, and are as a rule common to a whole rural area. Facilities are also provided for connecting an emergency charging plant for use in the case of breakdown or extensive repairs.

Fig. 13 shows a power plant with a circuit in accordance with Fig. 11 and equipped with a 12 ampere single-phase rectifier, the approximate output curve of which is given in Fig. 14.

In general, three-phase rectifiers are used for the larger outputs. Figs. 15 and 16 illustrate a powerboard with a circuit in accordance with Fig. 12. This board is of the all metal type. Fig. 17 shows one on which all the equipment,

excluding only the rectifier and the telephone type relays, is mounted on slate panels. The layout of the equipment on both types of boards is such that it can be used for offices with a maximum drain of 100 amperes. In order to reduce the initial cost it is usual to supply one rectifier only at the outset, but provision is made for connecting a second rectifier when required. This second rectifier, not shown on the circuit, is connected to the mains only when a current relay in the discharge lead indicates that one rectifier alone is insufficient to carry the load.

In general, a rectifier is chosen of sufficient output to carry the full busy hour drain normally required by the exchange equipment, in which case the full battery capacity is always available. As an alternative it is practicable to use a rectifier which, during the busy hour, supplies only a portion of the total current, the remainder being furnished by the battery which is recharged

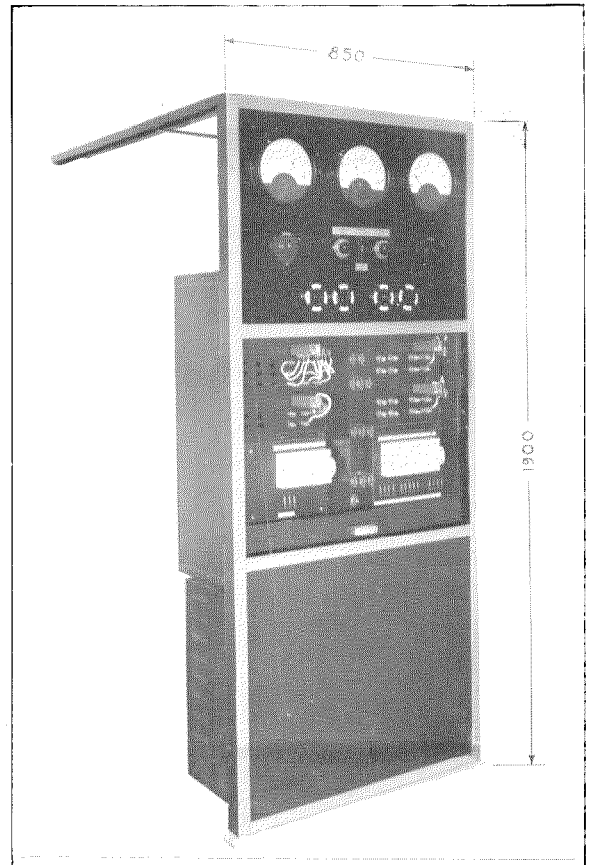

Fig. 16—Power Plant with a Circuit in Accordance with Fig. 12.

during the slack period. The capacity of the battery, however, must be such as to provide adequate reserve should a power failure occur immediately after the busy period of the day when the cells have already to some extent been discharged.

5. Power Plants for Use on D-C. Systems

Where a direct current supply with the positive pole earthed is available, the simplest arrangement is to charge the battery directly from the mains with a suitable resistance in series to reduce the current to the correct value. Whether a motor generator is used in preference to this simple direct charging scheme depends largely on the voltage of the d-c. supply. In areas where the supply is 220 volts, 3-wire, with the neutral earthed, the battery can be charged between the 110 volt negative pole and the earthed neutral. The efficiency of this arrangement is about 50%, which is equal to that obtained with a small motor generator, the efficiency of which is between 45% and 60%. Direct charging from the mains is therefore recommended when a 110 volt supply is available, the charge being preferably controlled by two resistances in parallel as described above. When the supply voltage exceeds 110, or the negative pole is earthed, a motor generator must be used. A method of control which gives satisfaction is the one whereby the motor generator is started when an ampere hour meter registers a discharge of 10% of the battery capacity, the charge being continued until the meter indicates that the battery is again fully charged. C.E.M.F. cells must be introduced into the discharge lead under the control of a contact voltmeter, in order to maintain the voltage at the exchange within the permissible limits during the charging period. This method is one which is not affected to any serious extent by variations in the supply voltage.

In order to reduce the first cost it is possible to use the compound generator arrangement, in which one or more C.E.M.F. cells are introduced into the discharge circuit at the same time that the generator is connected to the battery. The speed of the motor generator is, however, affected by variations in the supply voltage, and this in turn causes variation in the output of the

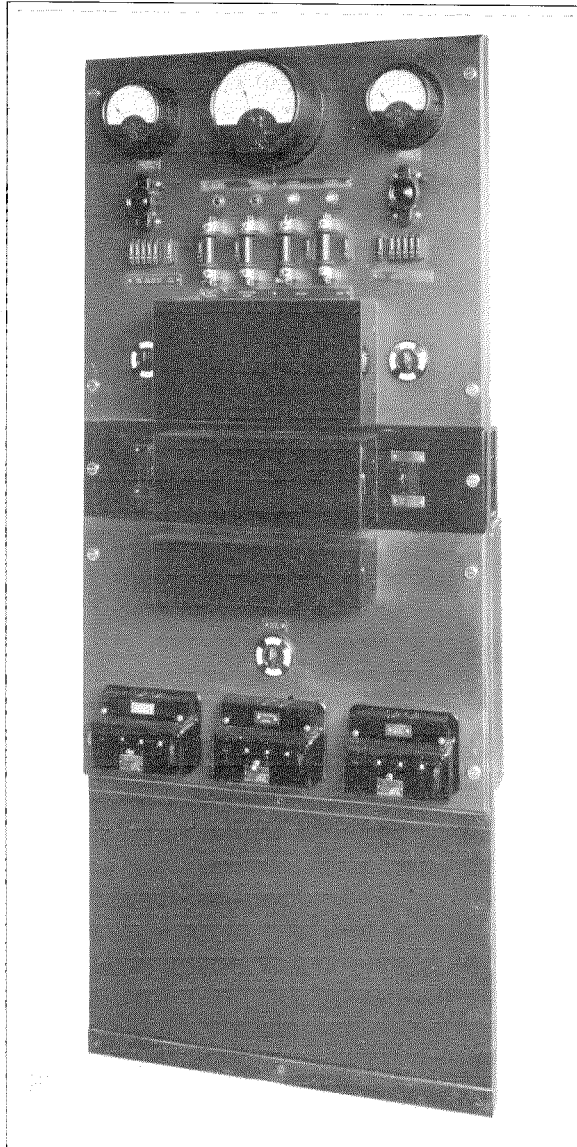

Fig. 17—Power Plant with all Equipment on Slate Panels.

generator. It would, therefore, be necessary to use an automatic speed regulator on the motor, an addition which possibly would not be sufficiently reliable for use in an unattended exchange. The arrangement is therefore less desirable for rural exchanges.

It has been found possible to dispense with the ampere hour meter by making use of a contact fitted on a clock. This contact starts the charge at a predetermined hour each day. It is preferable to arrange for the charging to take place during the busy hours, since this will ensure that

the major portion of the current required by the exchange is furnished directly by the generator. Once started, the charge continues until the voltage of the battery indicates that it is fully charged. C.E.M.F. cells are introduced one at a time, the first when the generator is connected to the battery. Additional C.E.M.F. cells are then added under the control of a contact voltmeter or voltage relay whenever the voltage at the exchange reaches the maximum limit.

6. Large Rural Exchanges

All the power plants thus far described are intended for use in unattended exchanges having a maximum busy hour drain not exceeding 100 amperes. For larger exchanges where the drain exceeds 100 amperes the requirements, generally speaking, are similar, but the number of such types of power plant is so considerable that anything approaching a complete description would be beyond the scope of this article. It may be of interest, however, to mention that the Bell Telephone Manufacturing Company has recently developed a full automatic operated, full float plant embodying the following features:

- (1) The plant can be operated either on a full float or semi-full float basis;
- (2) Single battery with emergency end cells, the latter used only when floating is stopped. The emergency cells are trickle charged from a small Selenium rectifier if the plant is operated on a full float basis;
- (3) Motor generators are used for floating or charging the battery. The voltage of these generators is regulated automatically by means of motor driven rheostats;
- (4) The number of generators which can be used in parallel is not limited. They are started and connected to the battery, or stopped, as required, in order to keep the battery at the floating voltage, i.e., between 2.1 and 2.2 volts per cell. All the generators in service, except the last one started, run at full load, the load variations being taken by the last machine;
- (5) For the purpose of giving a maintenance charge, it is possible to float at a voltage higher than 2.15 volts per cell by introducing C.E.M.F. cells manually into the battery discharge lead;
- (6) The type of generator used is such that, with the addition of electrolytic condensers, the exchange can be fed directly from the generators with the battery entirely disconnected.

It should be mentioned that the operation of an exchange without a battery is not considered advisable. If it is necessary to disconnect the single battery for repair, extension, or any other reason, it is preferable to provide an emergency battery, consisting possibly of car starter batteries. If this precaution is not taken, the slightest interruption in the main supply will result in the loss of all the exchange connections, with the probability of serious overloading when the supply is reestablished. In the larger exchanges it is the usual practice to arrange for the single battery to consist of two or more "strings" of cells connected permanently in parallel but arranged so that one "string" may be disconnected at a time for maintenance or repair.

Public Address Installation for the Performances of "Le Vray Mistère de la Passion" on the Place Du Parvis in Front of Notre Dame Cathedral, Paris

By G. MEUNIER

Le Matériel Téléphonique, Paris, France

General

Magnitude of the Performances

TO make use of one of the principal Paris public squares—150 metres long, 90 metres wide—as an open air theatre; to erect thereon a metallic flooring, rising from the ground level progressively up to 12.50 m., for the seating accommodation of an audience of more than 10,000 people, with the safety, exits, visibility, and comfort of the best theatres; to present the foremost French actors, assisted by a chorus of 1,500 and the Republican Mounted Guards on a stage 50 metres long by 25 metres wide; to provide a spectacle having the magnitude and solemnity of Notre Dame Cathedral as an incomparable scenic background—such, for the past two years, has been the principal achievement of the Comité des Fêtes de Paris on the initiative of the great promoter of open air theatricals: Pierre Aldebert. The production, "Le Vray Mistère de la Passion," harmonising perfectly with the surroundings, virtually makes these performances the chief attraction of the "Fêtes de Paris," held in the beginning of June of each year.

Enumeration of the many difficulties encountered in the realisation of this gigantic chef-d'oeuvre and the manner in which they were overcome will not be attempted in this paper. It will readily be appreciated, however, that immobilisation for a period of three weeks of the whole of an important and busy district of Paris, necessitating diversion of the heavy street traffic, and the coordination of stage mob movements on a vast scale with accompanying sound and lighting effects were tasks not easily accomplished. Similarly, the erection in record time, of scaffolding capable of supporting, with the requisite safety factor, such a considerable

audience, and the transformation of an historical monument like Notre Dame into a theatrical scene without hindrance to the regular religious ceremonies, involved technical and administrative problems which required most effective resolution by the organisers and their collaborators.¹

In installations of this character, two essential elements, obviously, are the lighting effects and the sound reproduction.

Scenic Dispositions

In order that the importance of the difficulties encountered in achieving scenic effects may be realised, it is necessary to note the particular circumstances accentuating them.

In addition to the dimensions of the public auditorium and of the stage, the latter was especially unfavourable to the placing of projectors, loudspeakers, or microphones, due to the absence of girders, columns, rails, etc. The stage, in fact, consisted of a plain, practically bare surface, showing the Cathedral façade almost in its entirety, and was surrounded on three sides with access slopes intended, in certain parts of the play, to permit a merging of performers and spectators. Some of the scenes—the Prologue and the Bearing of the Cross—were played off-stage, such as in the passage separating the stage from the spectators.

The rear of the stage was lined on the left and right by two walls, 3 metres high, with two kinds of thrones representing "mansions," which harmonised with the Cathedral and which resembled the theatrical effects of the middle ages. The central portion disclosed, according to the scene,

¹ From a technical point of view, mention may be made of the firm which built the seating accommodations: Société Entrepouse de Paris, and the lighting contractor: Etablissements Jaccopozi of Paris.



Notre Dame Cathedral showing the Stage and about One-Half of the Auditorium. The Operating Switchboard is in the foreground and the Auditorium Loudspeakers are Visible at the Extreme Left.

either the portal of Notre Dame, or scenery representing the Calvary. No curtains or accessory paraphernalia facilitating the concealment of lighting fixtures or microphones were used.

The only visible projectors and loudspeakers were those placed on the right and left extremities of the auditorium. On the stage, five cases, hardly 40 cm. high, were placed at the top of the front slope opposite the audience. These boxes contained lighting projectors, microphones, and loudspeakers.

The Public Address System

The requirements for the public address system as a whole were:

(1) Retransmissions, throughout the entire square and auditorium, of the musical programmes performed within the Cathedral, such as choir renditions, organ solos, and other musical contributions (violins, cellos, and "Martenot" waves—etherodyne musical apparatus). These retransmissions, with variable power according to the scenes of the "Vray Mistère," had to be accomplished in a manner such as to give the audience the impression that the music was emanating directly from Notre Dame itself. It was, therefore, necessary to avoid having a single acoustic focus. In the last scene, the sound had to give the impression both of increasing power and of rising from the ground up to the top of the towers. Sufficient power was then required to cover the bells and chimes ringing a full peal, as well as the trumpets of the Republican Guards occupying the right and left of the stage.

(2) Amplification, over the entire area reserved for the public, of the actors' voices from any part of the stage or from the intervening space between the stage and the first rows of spectators' seats. In so far as practicable, it was necessary that the impression be conveyed that the sound was coming directly from an actor moving about the stage.

(3) Amplification of the voices of actors representing apparitions. In these cases, the movements of the actors were restricted and the microphones were placed as near to them as possible.

(4) Amplification and retransmission of the chimes of the Rouen Cathedral to Paris by telephone cable (140 km.). To avoid confusion with

the bells of Notre Dame, this carillon emanated from loudspeakers placed on either side of the spectators rather than from the loudspeakers on the façade of Notre Dame.

(5) Placing at the disposal of the stage manager a telephone installation duplicated by transmitters connected with loudspeakers and lamp signals, so as to provide for a perfect coordination of all the elements, some of which were located far apart.

Main Difficulties of Realisation

The main difficulties involved were the following:

(a) To obtain a perfect retransmission of the musical part of the programme, with adequate pressure and the quality necessary to cover effectively the whole square, "Place du Parvis."

(b) To amplify, under the unfavourable conditions described above, the voices of the actors, apparitions, and chorus, with special reference to the solution of the problem of the "Larsen effect" (singing or reaction of loudspeakers on microphones).

Power and Quality for Musical Retransmissions

It was estimated that the average acoustic power of the Cathedral chimes at the center of the square would be from 6 to 10 Baries, and it was necessary to attain this value as a minimum. Taking the amplitude of acoustic pressure as p , and the acoustic resistance of the atmospheric air as r (equal to 42 c.g.s. units), the acoustic power flowing through a surface S cm.² is

$$W = \frac{p^2}{2r} S.$$

Hence, in order to obtain a pressure of 10 r.m.s. Baries, that is an amplitude of $p = 14$ Baries:

$$\begin{aligned} W &= \frac{196}{84} \times 8400 \times 10^4 \times 10^{-7} \text{ watts,} \\ &= 19.6 \text{ watts.} \end{aligned}$$

One can thus estimate the necessary acoustic power from 15 to 25 watts in the working angle of the loudspeaker. Such a loudspeaker, especially one possessing remarkable acoustic qualities, was not in current use; and, moreover, the usual solution of grouping several loudspeakers



Giant Loudspeaker.

in one place was not satisfactory because of the probable occurrence of stationary waves. The problem, in fact, was a delicate one, particularly as the apparatus on the façade of the Cathedral had to be practically invisible.

The "Larsen Effect" on Theatrical Retransmissions Including Apparitions

The amplification limit of a loudspeaking system is reached when the effects of the loudspeaker and the original sound on the microphone become equal. From this moment on, the sounds maintain themselves. Often the frequency first maintaining itself is not one that was originally present but rather, one that is most favoured by the whole installation: local conditions (frequency of resonance of the locality), the relative positions of the microphones and loudspeakers, and the presence of absorbing or reflecting screens. "Singing" is thus, in general, produced by a frequency different from the frequencies originally transmitted, and before the limit is reached for the latter. Before the "sing-

ing" phenomenon proper occurs, that is, at slightly lower amplification, resonance takes place through successive amplifications (with attendant attenuation in transmission) of the favoured frequency or of other frequencies registered by the microphones, the result being similar to the phenomenon of reverberation produced in a room with echo effects. In order to avoid these objectionable phenomena, the amplification coefficient must be kept appreciably below the "singing" point.

For sounds of given power there exists, therefore, even with microphones of high fidelity and stability, a distance beyond which it is impossible to obtain in the loudspeakers power sufficient to meet the requirements of a large assembly. This determines what is termed the "microphone field." When several microphones are connected simultaneously in the same installation, the respective field of each, in general, decreases; for, at certain frequencies, the combined action of the loudspeakers on the microphones is in phase and this augmented effect

correspondingly lowers the amplification coefficient at which "singing" takes place. The advantage of multiple microphones is dependent upon their being connected-in properly at any given time, either one, two, or three, as required.

The problem is, therefore, one of switching, and may be considerably simplified by the judicious choice of suitable apparatus, particularly microphones and loudspeakers.

Material

Loudspeakers

The electrodynamic type, with a small diaphragm, air chamber, and exponential horn was chosen because of its robust and water-tight construction, ease of installation, high efficiency, and, above all, its very pronounced directional qualities, permitting coverage of greater distances.

In order to simplify installation and reduce fire hazards, the model used for the "Vray Mistère" was of the permanent magnet type. The horns were 2 m. long and 80 cm. in diameter. Where there was insufficient room to locate these horns, they were replaced by flat flare horns 1.70 m. long, 1 m. wide, and 35 cm. thick, or by wooden horns of the compact type only 35 cm. in width.

Microphones

The electrodynamic type of microphone was chosen on account of its adaptability to operation in all positions, its insensitivity to mechanical vibration (thus requiring no elastic supports, and consequently facilitating installation and concealment in the scenery), its insensitivity to hygrometric variations of the atmosphere, and its water-tightness (on several occasions these

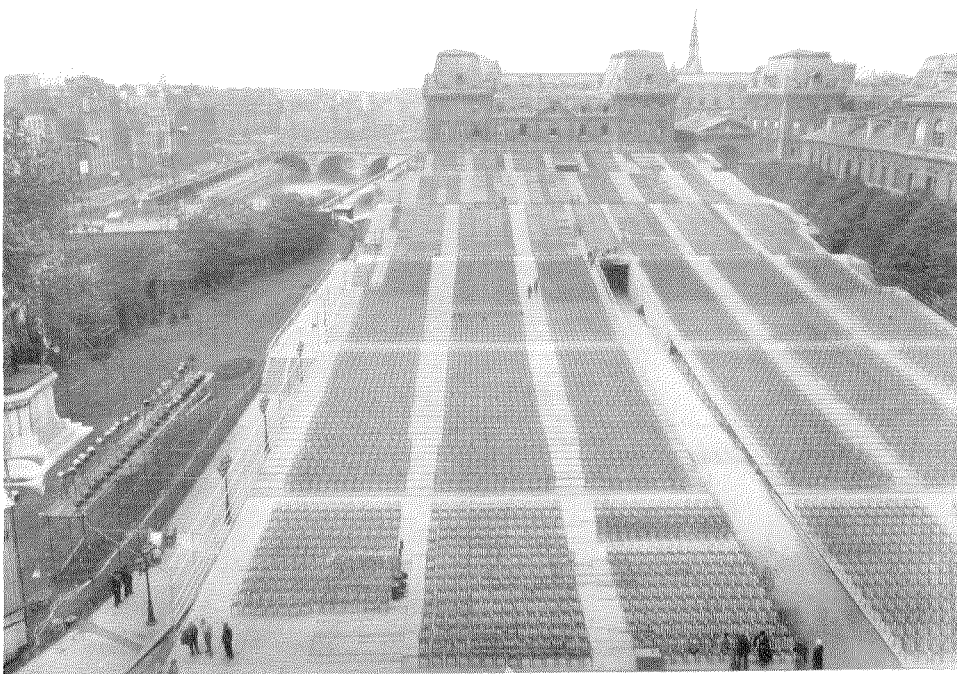

Place du Parvis, showing the Auditorium as viewed from the Cathedral. The Prefecture de Police is in the background, and the Hotel-Dieu Hospital to the Right. The Auditorium Loudspeakers are Visible at the Left.

instruments operated in the rain), as well as its fidelity of reproduction, its low impedance (permitting the use of relatively long lines between the microphones and the amplifiers), and, finally and more important, the possibility of connecting several microphones on the same preamplifier without special precautions against reactive effects.

Two types were used: the "non-directional" type in places where the sound impinged from all directions; the "directional" type in other cases. Fifty microphones were used in the installation.

Amplifiers

Amplifiers with fairly flat frequency response were required in order to avoid "singing" on an enhanced frequency. In addition, it was considered necessary to secure high quality even at low speech levels. Class "A" amplifiers, ten in all, with 15 and 30 watts of acoustic power, therefore, were used. Because of the high power required, a class "B" type amplifier was used for musical retransmissions.

High quality preamplifiers—one per group of microphones—were also employed. The preamplifiers and amplifiers, fed by the town current supply, were grouped at one point, thus facilitating supervision and permitting quick adjustment if necessary.

Realisation of the Musical Retransmission

Microphones

Three microphones, two of the "directional" type mounted on pedestals 2.50 m. high, and one of the "non-directional" type suspended over the gallery of the great organ, were used with appropriate mixers to pick up the instrumental and choir music to be retransmitted. The placing of the artists with respect to the microphones was such that the resonance of the Cathedral was correctly apportioned in the retransmission.

Ordinary Loudspeakers

Four electrodynamic loudspeakers with flat horns were fitted in between the railings of the Gallery of the Virgin at a height of about 25 metres, and were distributed over the whole width of this gallery so as to ensure the required

dispersion effect. They were fed by a 15-watt amplifier and covered the first third of the square.

Four similar loudspeakers were located on top of the towers. Operated by a 30 to 40 watt amplifier, they were intended to give the final sonorous ascent effect and were used only for this feature.

Special Loudspeaker

In order to obtain the requisite quality and power at the centre and rear of the square, a "giant" loudspeaker was especially constructed for the purpose. It employed twelve electrodynamic motors of the current type and a single straight exponential horn 6.80 m. in length with an aperture greater than 8 square metres.

This loudspeaker, possessing an efficiency estimated at 25% and giving a considerable directional effect, yielded the desired result. The peak of acoustic power at the amplifier outlet was 90 watts, the average being 40 to 50 watts. Moreover, the quality was greatly superior to that of current types of loudspeakers, especially at low frequencies.

The speaker was mounted on the platform between the two towers and behind the gallery joining them at their base at a height of approximately 50 metres.

Operation of the Installation

For broadcasting the theatrical performance with musical accompaniment the giant loudspeaker was nearly always employed alone in order to avoid interference with the actors' microphones. For retransmitting solos and music from the choirs and organ, during intervals of scenery changes, the loudspeakers in the Gallery of the Virgin were added at full power in order to give the first rows of spectators the impression of sufficient volume.

Because of the considerable directional effect of these loudspeakers, the sound coverage between these two groups of loudspeakers took place at a distance from the Cathedral such that no echo effects were noticeable. For the final scene, the ascension of the sound was obtained in the following manner: the loudspeakers in the Gallery of the Virgin were first worked alone at low volume; then, progressively, the loudspeakers

in the towers were amplified while those in the Gallery were being diminished to zero. At last, the central loudspeaker was placed in operation with gradual increase in volume.

During the performance, claps of thunder were imitated on the organ and with the "Martenet waves." Since the volume was adequate, the impression given was most realistic.

Realisation of the Theatrical Retransmissions Including Apparitions

Central Operating Switchboard

Operation of the Microphones

In the successive switching of the microphones, precautions had to be taken to prevent difficulties due to distortion, power variation, switching noise, and clicks. Rapid and easy switching was required.

Finally, all the public address operations and their control had to be handled from a central point in the public auditorium. It was necessary for the control operator both to see and hear the actors in order to follow the action.

The main idea was to establish a switchboard from which switching of microphones could be effected through a single lever, capable of motion in two directions at right angles to each other. Each position of the lever corresponded to a given point on the stage, i.e., the connection of the microphone covering the amplifiers. For adequate microphone field coverage and to permit encircling an actor placed in the midst of four microphones, an intermediate position was arranged between each main position of the lever for the interconnection of two adjacent microphones.

On account of the distances involved, the microphone switching could not be accomplished directly from the switchboard. A relay box placed under the stage and functioning as a junction box between the microphones and the cables connecting them to the preamplifiers was therefore utilised.

A signal board equipped with lamps completed the switchboard unit and at any moment indicated to the operator the microphones in operation. It included an individual key per microphone enabling each microphone to be switched in or out separately. The latter arrangement proved especially useful in lengthy scenes

when rapid interchanges occurred between widely separated actors and when the simultaneous operation of distant microphones was necessary.

Associated with the above mentioned operating lever was a cancellation key of the push type, permitting suppression of the previous setting. Lamps of suitable color indicated the combination effected. Preparation of a microphone set-up before actually switching it in was thus a simple matter.

A repeater signal board, indicating only the microphones actually connected, was provided for the stage manager.

The relay box controlling the microphones was designed so that each relay operated a microphone and a signal indicating its connection. The signaling device consisted of a pilot lamp, or of a more important visual "SILENCE" signal which functioned through relays and which was used in connection with the projector microphones to warn the operators of their operation. For special retransmission and other purposes, the signal was also used in connection with certain microphones located in the wings.

Power Control

Power control was effected from the relay box unit. Since it was, impracticable, for reasons of location, distance, and safety, to locate the preamplifiers within this unit, all adjustments were made through artificial lines connected between the preamplifiers and the power amplifiers. Independent adjustability of amplifiers and, in some cases, of loudspeakers was required for achieving the necessary flexibility and reliability. Power adjustments could be made prior to the operating periods.

In addition to individual operating keys in the control switchboard, the relays were arranged for operation by the general level of the microphones. Amplifiers and preamplifiers were thus added or suppressed as required, and perfect quietness of the installation was attained. Pilot lamps also indicated the potentiometers in service and facilitated control of the equipment.

Loudspeakers

The three groups of loudspeakers for the apparitions—Heaven, Hell, and the Gallery of the

Virgin—were placed as close to the point where an actor was speaking as was possible without danger of “singing.” In most cases the actors, being motionless, supported the microphone themselves, and the loudspeakers—two per apparition—were at a distance of from 3 to 4 metres from the actor. The directional effect thereby obtained was perfect, provided other microphones were not operating simultaneously.

The loudspeakers transmitting the actors' voices from the stage were mounted on either side of the public auditorium: on the buildings of the Hotel-Dieu Hospital lining the square on the left, and on metal pillars 15 and 20 metres in height on the right. The whole surface of the auditorium was divided into six zones, each zone being simultaneously covered by two loudspeakers (or groups of loudspeakers) belonging, respectively, to the group on the right and on the left.

Analysis relative to the disposition of these highly directive loudspeakers showed that:

- (1) In order to avoid echo effects, the difference in distance between the spectators of one zone and either the actors or the loudspeakers should not exceed 22 metres.
- (2) The two loudspeakers covering any one zone should be at approximately equal distances from the centre of the stage.

This disposition of loudspeakers made it possible to give a more or less perfect illusion that the sound was coming from the centre of the stage. To approximate the binaural effect, the relative intensity of two groups of loudspeakers was varied.

While additional arrangements were made for the coverage of the front rows, spectators seated there were at some disadvantage as regards acoustic effect, as were also those in the lateral zones who were located too close to one or the other of a group of loudspeakers.

Complementary Installations

Complementary equipment was not installed on as elaborate a scale as the public address system, but its function was of no less importance, since it enabled the stage manager and his different collaborators to act quickly. This subsidiary equipment consisted mainly of ordinary

telephones, loudspeakers for giving orders, and light signals.

Telephones

A central battery manual telephone switchboard provided facilities for interconnection to the stage manager, the electricians, the public address operating switchboard, the main points of the performance, the organ gallery, the control points of the loudspeakers (galleries, platforms, and towers), and the distant apparitions, totaling approximately 20 points. A special telephone line was reserved for coordinating the chimes from Rouen. A skilled telephone operator was in charge of the switchboard.

Paging by Loudspeakers

A microphone was at the disposal of the stage manager, who by means of a keyboard could communicate instantly with the electricians, the organ gallery, or the public address operating switchboard. At the latter point, instructions were not given through loudspeakers, which would have disturbed the audience, but through head phones to a second operator assisting the first one. These head phones were subsequently left in permanent connection with the microphone of the stage manager so as to be in closer touch with him and to repeat the orders passed to other posts.

Special precautions were taken to prevent the stage manager from using the loudspeaker at the organ by mistake while the adjacent microphones were working. Such use would have resulted in the retransmission of the orders throughout the square. When these microphones were connected, an imperative warning was given to the stage manager by a pilot lamp near the operating key of the loudspeaker; moreover, a relay then prevented the use of this loudspeaker. An additional operation allowed the stage manager himself, in case of necessity, to cut off the microphones of the organ to convey an urgent order.

Signaling

Certain starting signals, especially for musical renditions, were given by a pilot lamp. Similar indications as to procedure also were used in connection with certain actors and their associated microphones.

Recent Telecommunication Developments of Interest

C OIN CHECKING DEVICE FOR AUTOMATIC COIN SLOT MACHINES. The constantly increasing application in public places of distribution machines for the purpose of facilitating the sale of commodities, railway tickets, and postage stamps, as well as in connection with in- and outdoor telephone service, emphasises the problem of finding means for preventing the dishonest use of such devices. To meet this need, the Bell Telephone Manufacturing Company, Antwerp, recently developed a coin checking mechanism which prevents refunding of coins through tampering and which, in addition, discriminates automatically between genuine and fraudulent coins.

The device may be adapted to any machine used for the dispensing of commodities or services. As developed to date by the Bell Telephone Manufacturing Company, it is comprised in a public pay station system for single coins (local full automatic) and multiple coins (suburban and interurban automatic).

Discrimination between genuine and fraudulent coins takes place in two ways: (1) dimensional checking, a method commonly used, but which must not be too close in view of the rather wide variations occurring in genuine coins; and (2) magnetic permeability checking.

Machines to be used in Belgium will take three coins, namely, 25 centimes (U.S.A. value 0.85 cents), 1 franc, and 5 francs. Because of the small value of the first mentioned coin, it was not thought worth while to guard against its fraudulent use other than by a check of dimensions. The two larger coins are composed of nickel alloy having a magnetic permeability intermediate between iron and non-magnetic material. Since fraudulent coins are most likely to be made of cheap material such as iron, brass, or zinc alloy, the machine is designed to pass only coins of suitable permeability.

For the separation of nickel alloy coins from iron and non-magnetic counterfeits, a magnetic scheme is utilised. Non-magnetic coins, of course, are not attracted to the magnet poles, while iron coins are firmly attracted. Nickel alloy coins on the other hand can be readily disengaged by a suitable force. Since the magnetic permeability of iron, compared to the Belgian nickel alloy coins,



is in the ratio of five to one, ample margins of safety are readily obtainable.

In designing the new mechanism, discrimination between genuine and fraudulent coins by weight was discarded. Genuine coins, because of variations in dimensions due to wear, vary rather widely in weight; and furthermore, discrimination of weight would require an accurate automatic scale. In addition, coins of cheap material but of equal weight could be used so that an automatic scale in any case would be of little use.

It is expected that the new pay station system will be placed in service in Belgium shortly. Details of this system, including the coin checking device, will be published in a later issue of *Electrical Communication*.

• • •

L IFEBOAT EQUIPMENT ON THE R.M.S. QUEEN MARY. Two of the twenty-four motor lifeboats carried by the *R.M.S. Queen Mary* have been equipped with special radio communication and searchlight equipment developed by the International Marine Radio Company Limited, London, the supplier of the entire radio installa-

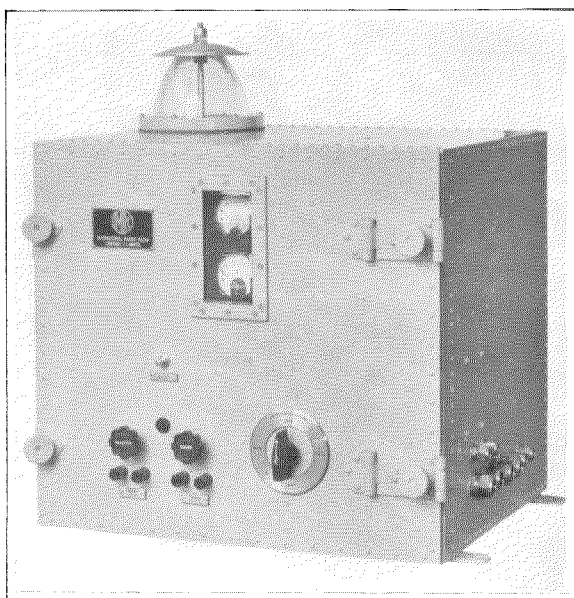

Transmitter and Receiver in Submergible Unit.

tion for the *Queen Mary*. In addition to the spark transmitting and receiving set required by law, a special radio telephone installation is carried by each of the two lifeboats, the *Queen Mary* being the first ship to be thus equipped.

The functions of the two radio-equipped lifeboats, in case of emergency, are to act as controlling agents for the rest of the boats, to shepherd them, and to maintain contact with rescue ships, with one another and, if necessary, with the parent ship.

The Type TG4 spark transmitter and receiver are combined in a single submergible unit which also houses auxiliary and testing gear. A battery-driven motor-generator, Morse key, headphones, etc., complete this section of the installation.

The quenched spark transmitter consumes 300 watts from the alternator, delivering an output well in excess of the Board of Trade requirement of 10 meter-amperes on the marine distress wavelength of 600 meters. The receiver is a 3-valve regenerative type. The accompanying illustration shows the simplified controls and conveys some idea of the rugged construction required for this type of service.

The telephone transmitter and receiver are separate units, comprising a standard trawler

type equipment. The transmitter (Type TS3) operates from a small battery-driven motor generator, and covers the "small ship" telephony waveband of 110 to 220 meters. The receiver (Type RM14) covers the band of 110 to 2,000 meters.

Both the telegraph and telephone sets derive their power supply from a common 22-volt nickel-iron battery and employ the same aerial, which is of the single wire type supported by collapsible masts. The operating range of both sets is well over 100 miles.

The searchlight, mounted on top of the radio cabin, also operates from the same battery and has an illumination range of some 700 yards.

• • •

INFRARED BURGLAR ALARM. An interesting application of infra-red rays and photo-cells for burglar alarm and similar services has been developed by the Bell Telephone Manufacturing Company, Antwerp, Belgium. The equipment consists essentially of a projector of invisible infra-red "light," a photoelectric cell responsive to infra-red rays only, and an amplifying system following the photo-cell. One or more mirrors permit the path of the infra-red beam to be deflected around corners or zigzagged across the area to be protected.

For burglar alarm use, the mains-operated amplifier is connected to an alarm signal circuit so that a momentary interruption of the infra-red light beam will sound an alarm continuously. Since the alarm circuit is battery operated, failure of the mains or the apparatus, whether deliberate or accidental, will cause the alarm to function.

The accompanying illustration shows the essential elements—the infra-red projector, mirrors, photo-cell, and amplifier.

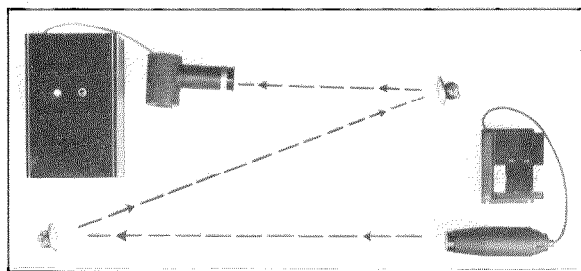

Licensee Companies

BELL TELEPHONE MANUFACTURING COMPANY.....	<i>Antwerp, Belgium</i>
<i>Branches: Brussels.</i>	
BELL TELEPHONE MANUFACTURING COMPANY.....	<i>Berne, Switzerland</i>
BELL TELEPHONE MANUFACTURING COMPANY.....	<i>The Hague, Holland</i>
CHINA ELECTRIC COMPANY, LIMITED.....	<i>Shanghai, China</i>
<i>Branches: Canton, Hankow, Hongkong, Peiping, Tientsin.</i>	
COMPAÑÍA RADIO AEREA MARITIMA ESPAÑOLA.....	<i>Madrid, Spain</i>
COMPAÑÍA STANDARD ELECTRIC ARGENTINA.....	<i>Buenos Aires, Argentina</i>
CREED AND COMPANY, LIMITED.....	<i>Croydon, England</i>
FABBRICA APPARECCHIATURE PER COMUNICAZIONE ELETTRICHE.....	<i>Milan, Italy</i>
INTERNATIONAL MARINE RADIO COMPANY, LIMITED.....	<i>London, England</i>
INTERNATIONAL STANDARD ELECTRIC CORPORATION, <i>Branch Office,</i>	<i>Rio de Janeiro, Brazil</i>
JUGOSLAVIAN STANDARD ELECTRIC COMPANY, LIMITED.....	<i>Belgrade, Jugoslavia</i>
KOLSTER-BRANDES, LIMITED.....	<i>Sidcup, England</i>
LE MATÉRIEL TÉLÉPHONIQUE.....	<i>Paris, France</i>
<i>Branch: Rabat, Morocco.</i>	
NIPPON DENKI KABUSHIKI KAISHA.....	<i>Tokyo, Japan</i>
<i>Branches: Osaka, Dairen, Taihoku.</i>	
SOCIÉTÉ ANONYME LES TÉLÉIMPRIMEURS.....	<i>Paris, France</i>
STANDARD ELECTRIC AKTIESELSKAB.....	<i>Copenhagen, Denmark</i>
STANDARD ELECTRIC COMPANY W POLSCE SKA Z O. O.....	<i>Warsaw, Poland</i>
STANDARD ELECTRIC DOMS A SPOL.....	<i>Praha, Czechoslovakia</i>
<i>Branch: Bratislava.</i>	
STANDARD ELECTRICA.....	<i>Lisbon, Portugal</i>
STANDARD ELECTRICA ROMÁNÁ, S.A.....	<i>Bucharest, Rumania</i>
STANDARD ELÉCTRICA, S.A.....	<i>Madrid, Spain</i>
<i>Branches: Barcelona, Santander.</i>	
STANDARD ELEKTRIZITÄTS-GESELLSCHAFT A.G.....	<i>Berlin, Germany</i>
STANDARD ELETTRICA ITALIANA.....	<i>Milan, Italy</i>
<i>Branch: Rome.</i>	
STANDARD TELEFON-OG KABELFABRIK A/S.....	<i>Oslo, Norway</i>
STANDARD TÉLÉPHONE ET RADIO, S.A. Zürich.....	<i>Zürich, Switzerland</i>
STANDARD TELEPHONES AND CABLES, LIMITED.....	<i>London, England</i>
<i>Branches: Glasgow, Leeds, Dublin, Cairo, Pretoria, Calcutta.</i>	
STANDARD TELEPHONES AND CABLES (AUSTRALASIA), LIMITED.....	<i>Sydney, Australia</i>
<i>Branches: Melbourne; Wellington, New Zealand.</i>	
STANDARD VILAMOSSÁGI RÉSZVÉNY TÁRSASÁG.....	<i>Budapest, Hungary</i>
SUMITOMO ELECTRIC WIRE & CABLE WORKS, LIMITED.....	<i>Osaka, Japan</i>
VEREINIGTE TELEPHON- UND TELEGRAPHENFABRIKS AKTIEN-GESELLSCHAFT, CZEIJA, NISSL & Co.....	<i>Vienna, Austria</i>

Sales Offices and Agencies Throughout the World
