

ELECTRICAL COMMUNICATION

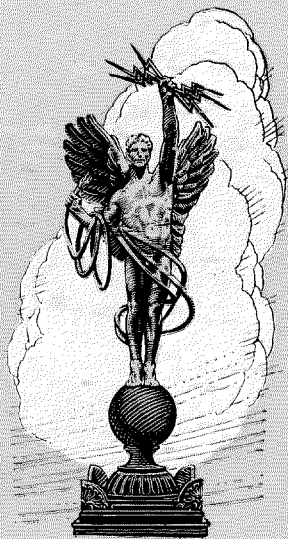

OCTOBER
1924

No. 2
VOL. 3

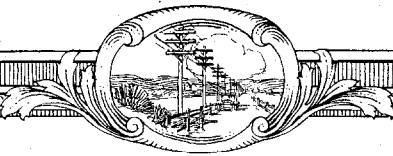

ELECTRICAL COMMUNICATION

A Journal of Progress in the
Telephone, Telegraph and Radio Art

EDITORIAL BOARD

F. B. Jewett
G. E. Pingree

E. B. Craft
H. E. Shreeve

F. Gill
E. A. Brofos

J. L. McQuarrie
P. K. Condict

J. F. Rhame, Editor

Published Quarterly by the

INTERNATIONAL WESTERN ELECTRIC COMPANY
INCORPORATED

195 BROADWAY, NEW YORK, N. Y., U. S. A.

Charles G. DuBois, President

George C. Pratt, Secretary

J. W. Johnston, Treasurer

Subscription \$1.50 per year; single copies 50 cents

Volume III

OCTOBER, 1924

Number 2

CONTENTS

- DESCRIPTION OF DAMAGES DONE BY THE EARTHQUAKE TO
WIRED AND WIRELESS TELEGRAPH AND TELEPHONE
INSTALLATIONS OF JAPAN..... 79
By S. Inada
- RESTORATION OF THE WORKS OF THE NIPPON ELECTRIC
COMPANY103
By A. G. Jillard
- THE STETHOPHONE.....106
By H. F. Dodge
- A TELEPHONE TRANSMISSION REFERENCE SYSTEM.....114
By L. J. Sivan
- CARRIER TELEPHONE EQUIPMENT FOR HIGH VOLTAGE POWER
TRANSMISSION LINES.....127
By N. H. Slaughtler
- SUPERVISORY SYSTEMS FOR REMOTE CONTROL.....134
By J. C. Field
- TELEPHONE AND TELEGRAPH STATISTICS OF THE WORLD...145

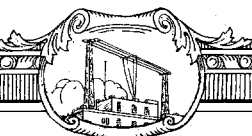

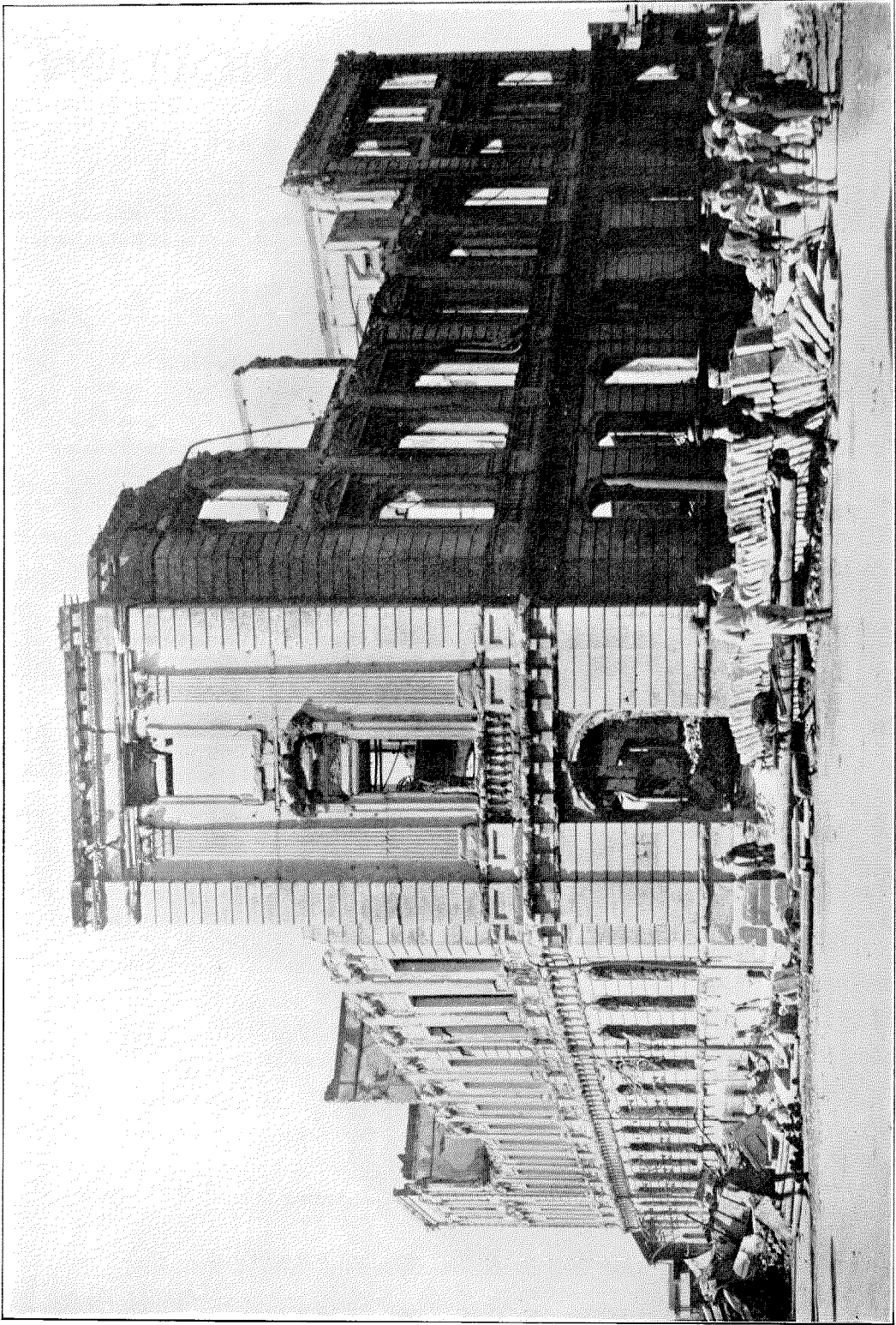

General View of Tokio Central Telegraph Office After Fire

A Brief Description of the Damages Done by the Earthquake to the Wired and Wireless Telegraph and Telephone Installations of Japan

By SANNOSUKE INADA

Chief Engineer of Technical Section, Department of Communications, Japan

THE most disastrous and appalling earthquake in the annals of Japan's history, which occurred at 11 o'clock 48 minutes 12 seconds A.M. on September 1st, 1923, caused many severe damages to the telegraph and telephone installations in Tokio, Yokohama and their vicinities; and a majority of the office buildings, equipments, and line plants in these localities was reduced to ashes by the conflagrations which spread immediately after the quake. Damages to these installations were so serious that they can never be fully stated in detail, but it is intended that general descriptions concerning them shall be given.

CHAPTER I.—TELEGRAPH

1.—Damages to Installations

The number of the first and second class offices damaged is given below:

District	Number of Offices	Burnt or Wrecked
Tokio and its Suburbs.....	23	13
Province of Kanagawa.....	8	7

The line plants connecting and terminating at the above offices were wiped out by conflagrations. The damages to the Tokio Central Telegraph Office caused not only an interruption of the entire central service of telegraphic function in Japan, but also of her international communications.

As soon as the quake occurred the 350 telegraph circuits, which terminate at the Tokio Central Telegraph Office, came to faults of contacts and earth; and the electrical source for telegraph was shut down by the tumbling down of the secondary batteries. Thus all the

circuits were interrupted, and at the same time all employees, rushing to outdoor, barely escaped being crushed by the destruction of walls on third floor. As this building was very old, a new central office in the centre of the city was in course of construction, reinforced concrete being used throughout. In spite of all efforts of the employees, all installations were reduced to ashes by fire on the evening of the first day; the principal equipments lost being as follows:

Equipment	Number Lost
Wheatstone Automatic Transmitter & Receiver.....	126
Quadruplex and Simultaneous A.C. & D.C. Duplex.....	Sets for 19 Ccts. & Spare
Duplex and Combined Dx-Sx... Simplex.....	Sets for 65 Ccts. & Spare Sets for 138 Ccts. & Spare
Syphon Recorder Duplex (for Bonin & Guam Cable).....	1 Complete Set
High Frequency Simplex.....	1 Complete Set
Western Electric Quadruple-Duplex Printer.....	1 Complete Set
Western Electric Start-Stop Printer.....	1 Complete Set
Teletype.....	2 Sets
Kleinschmidt Keyboard Perforator.....	17 Sets
Telegraph Switchboard.....	2 Sets
Monitoring Set.....	5 Sets
Pneumatic Tube Equipment...	14 Sets
Ticker.....	126 Sets
Testing Equipment.....	Complete Set

The underground cable between Tokio and Yokohama was burnt or crushed in Yokohama and near the river Rokugo, and totally damaged near the river Banyu, where the cables were suspended by arms attached to the piers of the railway bridge. Disaster in the vicinity of Hakone was so serious that no pole line remained on account of the cracks and failures in the ground. One may easily gauge the magnitude of the disaster by referring to

Figure 1, which shows the damage done to a pole line in Yokohama.

As a result of the first quake, the Guam cable, the only cable which connects Japan with the United States of America, went down to fault and was interrupted. For urgent repairs "Okinawamaru" was ordered to steam hastily from Nagasaki, and after strenuous endeavours, co-operating with two other cable ships, "Ogasawamaru" and "Nanyomaru," faults were cleared on October 27th. The latter cable ship, being then anchored at Yokohama, supplied cables and other materials to "Okinawamaru" needed for the repair, and

fathoms. Locations of these faults were as follows:

Fault	Distance Along Cable from Etchujima
Point No. 1	About 44.5 Knots (About 5 Knots off Kachiyama, Westward)
Point No. 2	About 45.5 Knots
Point No. 3	About 46.1 Knots
Point No. 4	About 46.6 Knots
Point No. 5	About 66.6 Knots
Point No. 6	About 74.1 Knots (About 10 Knots off Habu Harbor in Oshima, Westward)

According to investigations, it seems that these faults were due to sudden shocks which



Figure 1—Cracks in Ground Near a River in Yokohama—Telephone Pole Near Center of Picture

the former made hasty trips to supply the necessary cables, carrying them from the cable tank at Nagasaki. The faults of this cable were grappled at 16 points along the route, at distances from 44 to 75 knots from Etchujima Cable House, where this cable is landed, operating both inside and outside of Tokio Bay at depths of sea measuring from 300 to 1160

were caused by the earthquake. The faults were breaks and grounding, and from an inspection of the faulty parts of this cable it was noted that it was broken with no elongation of armour steel but as if a tremendous stress had been applied suddenly. By the fact that at some points the cable seems entangled forcibly, it can be imagined that these faults

might have occurred at points where some part of the cable was buried under the sea bed according to its sudden change.

It may be added, in passing, that the condition of damage on the Sakurajima submarine cable, which connected Kagoshima and Sakurajima island, and which

was repaired before communication between Tokio and Guam was restored.

2.—Emergency Measures

As a consequence of the entire break-down of the Tokio Central Telegraph Office system, it was planned on the afternoon of the very

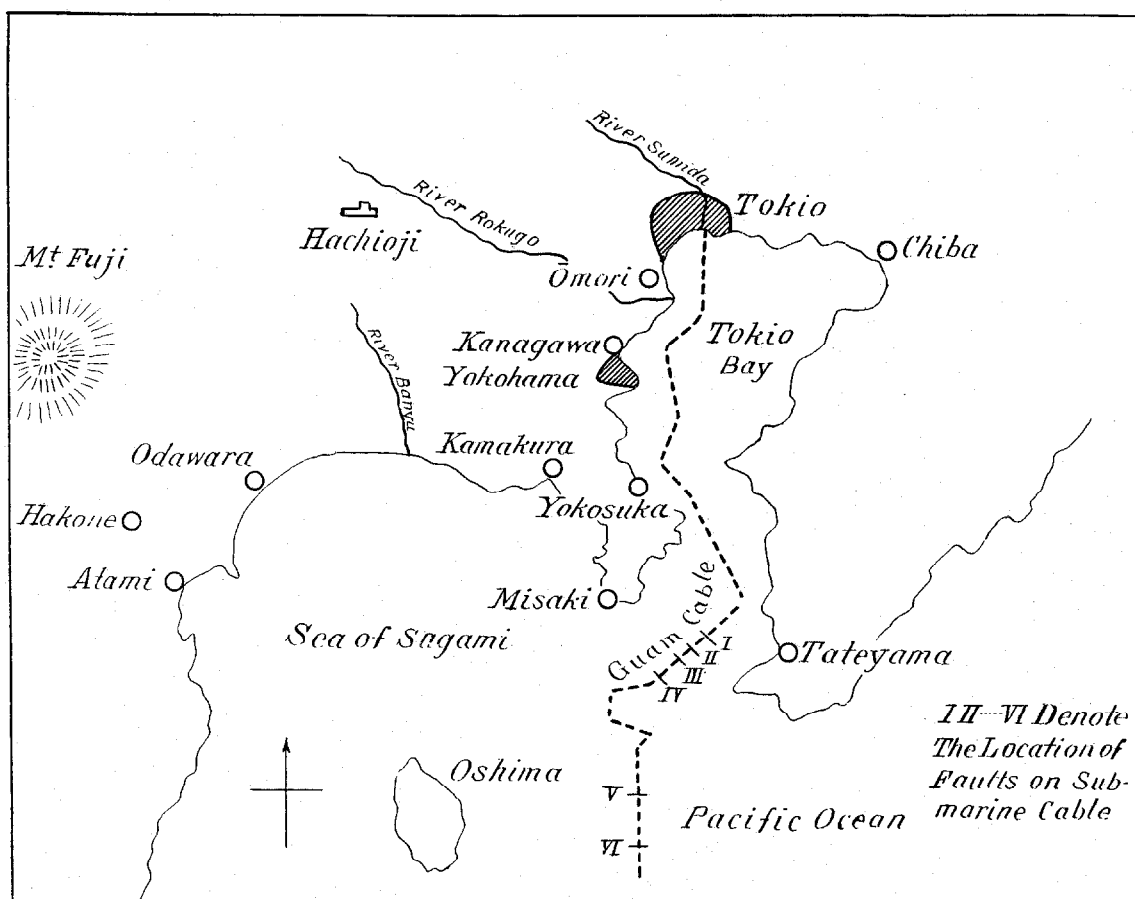

Figure 2—Map of the Severe Quake Area on September 1, 1923

was affected by the eruption of Sakurajima island of January 1914, was nearly the same as that of the Guam cable above mentioned. At one or two feet from the end of the cable break, the inner serving of the former cable was snapped at quite numerous points.

The underground portion of the Guam cable from cable house to Tokio Central Telegraph Office, which is of four cores of I.R. cables was also burnt at several bridges on its route, but

day of the disaster to open a temporary telegraph office in the building of the Communication Officers Training Institution in Shiba Park, but that plan fell completely to the ground, as the building was burnt in the early morning of the second day. Thereupon it was decided, first of all, to connect Tokio with other important cities at some point in the suburbs of Tokio. For this purpose Senju office, which is situated in a part north-east of Tokio, was chosen from the standpoint of routing. Communication concerning relief busi-

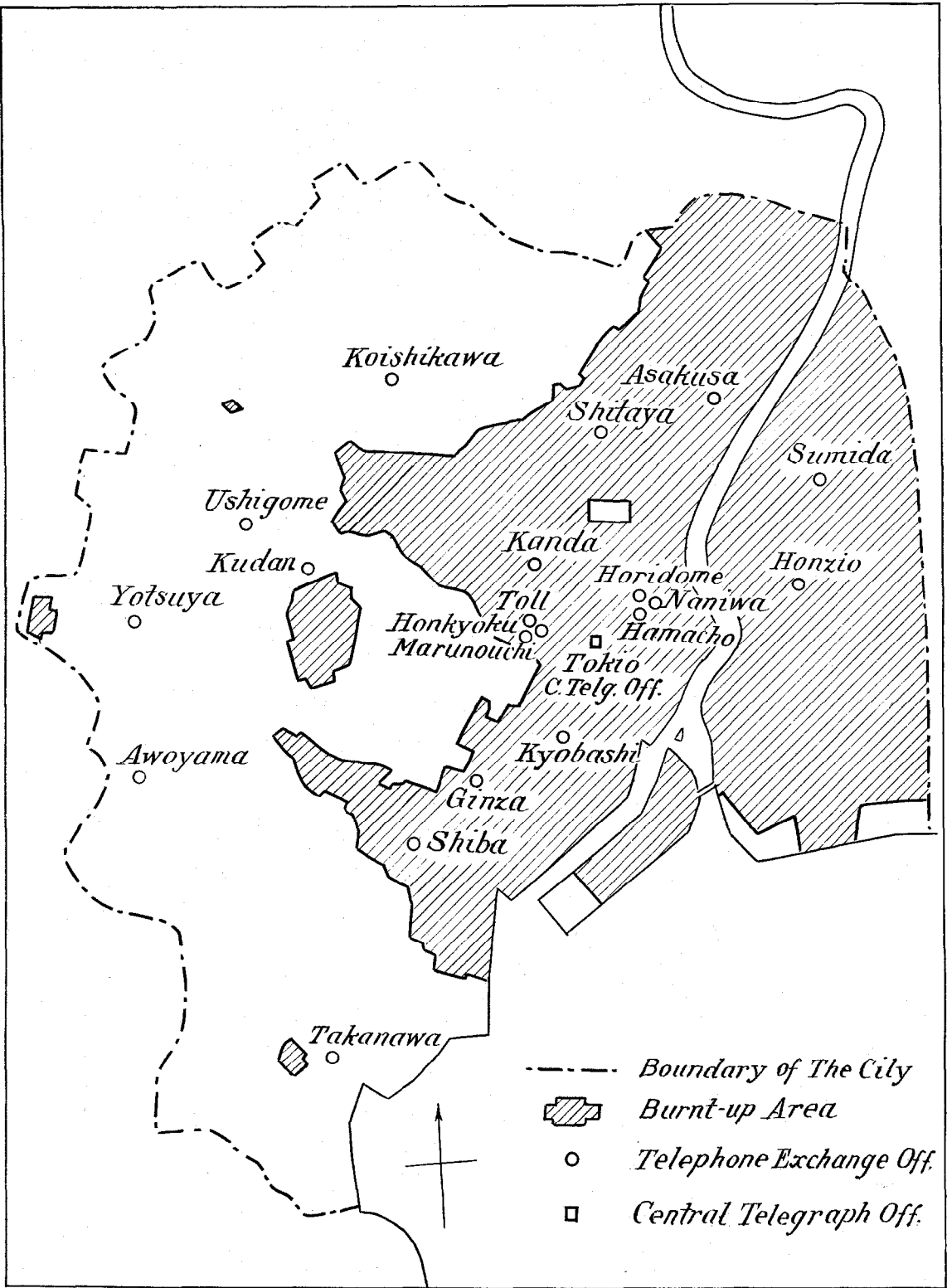

Figure 3—Map of Burnt Area in the City of Tokio

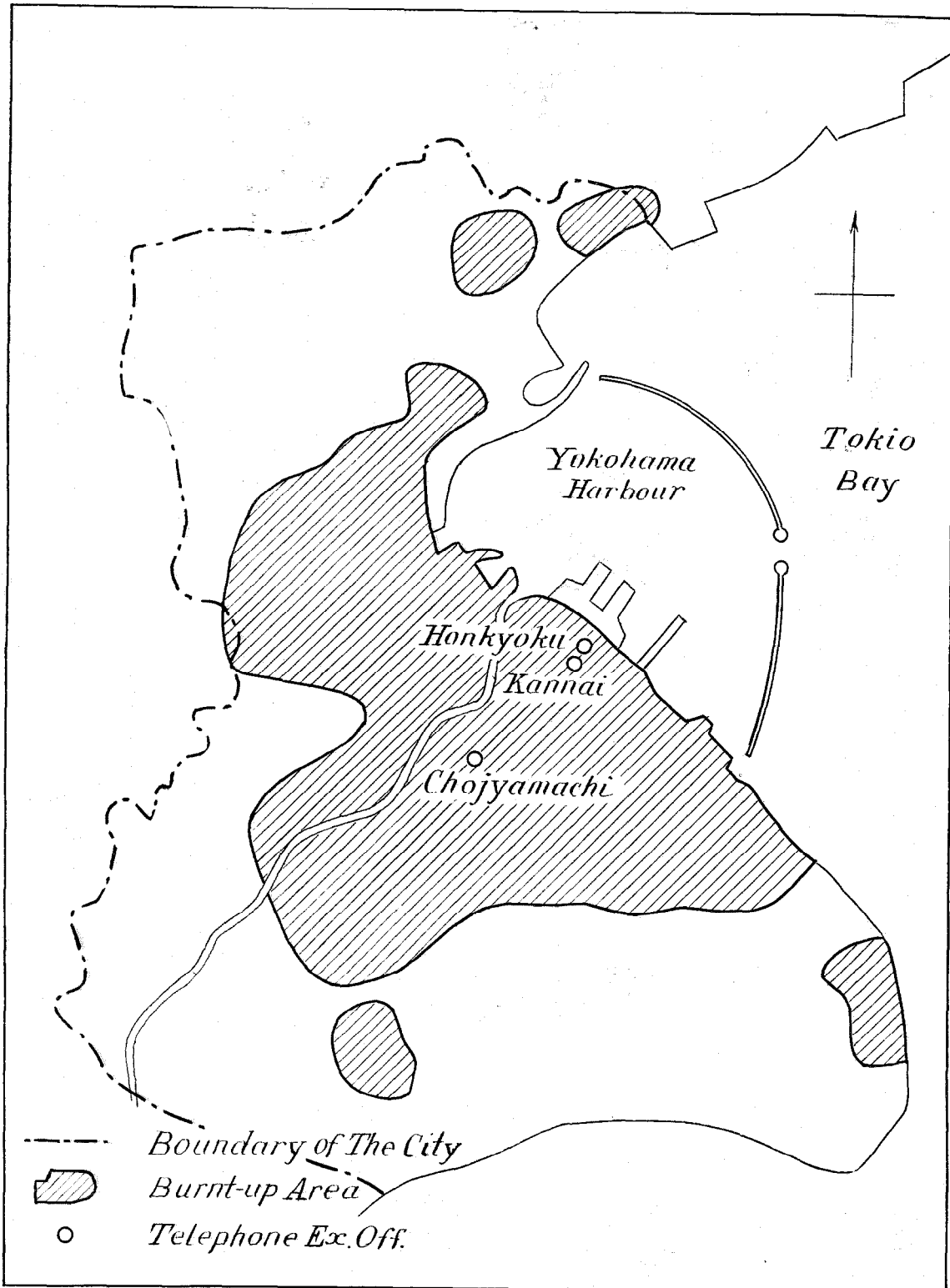

Figure 4—Map of Burnt Area in the City of Yokohama



Figure 5—General View of Ruins of Telephone Central Honkyoku, Yokohama

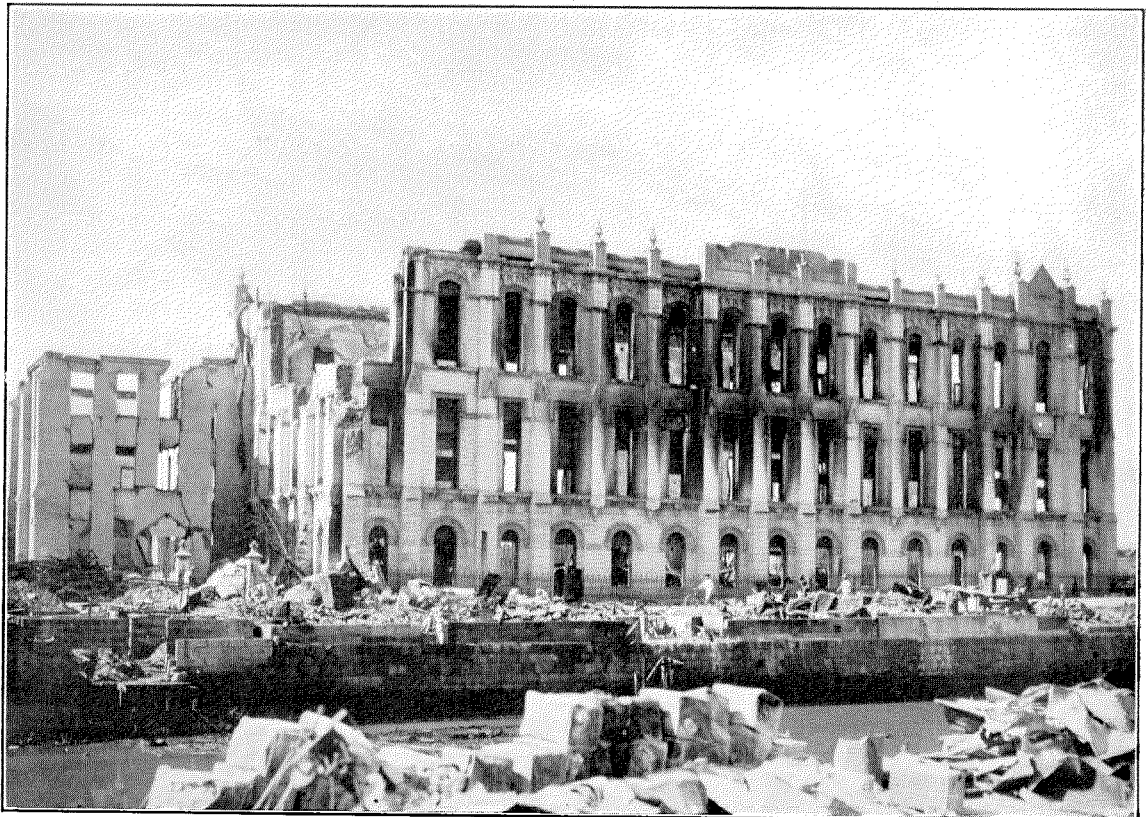

Figure 6—Outside View of Telephone Central Kyobashi, Tokio, After Fire

ness was successfully opened with Osaka, Nagoya and Sendai at 11 P.M. on the second day. This was done, indeed, in the midst of heat from the embers in the burnt districts and prevailing oppressions with dread. As shown by the map (Figure 3) the central and the busiest portion, or nearly one-half of the area of the city of Tokio was burnt; it was a very difficult task to find out an appropriate site for the central office.

For convenience sake it was planned to open the temporary central telegraph office in the building of Tokio Central Post Office, which fortunately escaped the fire. After much effort instruments and materials were gathered from all districts. On the other hand, by jointing together underground cables of telegraph and telephone, which remained undamaged in the city, it was possible to open communication from centre of the capital to the cities of Osaka, Nagoya, Nagasaki, Kobe, Sapporo and Nagano; one after another in the period from the fifth to eighth day. At the same time a temporary circuit between the central office and the radio station in the Telegraph Corps at Nakano, a suburb of Tokio, which served to connect other radio stations and the central office, was constructed by a force from the Telegraph Corps.

On the 14th the temporary Tokio Central Telegraph Office was removed to the fourth floor of Eiraku building, where emergency circuits terminating at Senju, Kameido and other places were cut over together. Thus the organization of the plant of the Tokio Central Telegraph Office was consolidated, which had been rather disorganized since the day of the disaster. Later, the number of circuits which terminated at this office were gradually increased, making a total of 65 on November 11th, and they afforded efficient service to all quarters of this country.

Concerning Yokohama, since the damages done to that city were so serious that many of our employees were killed and injured, any sort of planning of emergency measures was very difficult. As nothing could be done in the centre of the city a temporary office was established at Kanagawa Station of the inter-urban electric railway between Tokio and Yokohama. On September 12th, a telegraph

service was offered to the public but with some restrictions, serving relief messages only as in Tokio. Communication from Yokohama to Kamakura and Yokosuka was commenced on the 17th. On October 24th, after removal of the temporary office to the barracks at Saku-ragicho, communication with Osaka, Shizuoka, Maebashi, Kyoto, Sannomiya and other places was reopened.

Traffic in the districts outside the affected area increased extraordinarily, especially at Osaka where it came up to over twice the daily service before the disaster, amounting to something over 188,000 messages on September 5th. At Sannomiya foreign messages dispatched during the first ten days of September increased by 80% in the number of messages and 250% in the number of words in daily average. As temporary measures for this extraordinary condition circuits as direct as possible from Tokio to the cities in Chugoku, Kyūshū and north-east districts were chosen making use of circuits which were interrupted. Although unexpected, owing to the makeup of the temporary circuits involved, satisfactory results were obtained by putting the duplex Western Electric type printer in use for foreign messages between Osaka and Nagasaki.

CHAPTER II—TELEPHONE

1.—*Damages to the Telephone*

(a) Damages to the Office-Buildings.

Number of centrals and the extent of damages sustained from the earthquake calamity are given in table shown on succeeding page.

In Yokohama the central Honkyoku was, as shown in Figure 5, wrecked entirely and many employees were killed or injured there. In Tokio, the central Kyobashi was, as shown in Figure 6, destroyed at its corner and several employees, here also, were killed or injured, the building afterwards burning to ashes. The centrals Shiba, Kanda, Naniwa, Shitaya and Honkyoku, being of brick construction, were damaged seriously and burnt to ashes afterwards. The central Kudan was damaged so seriously that it can not be used again, owing to the cracks in the walls or unrepairable damages to the main structures. As for the remaining centrals such as Sumida, Ginza, Hamacho,

City	Extent of Damage	Number of Offices	Type of Building Construction
Tokio	Damaged Beyond Repair	8	{ Stone Work 1 Reinforced Concrete 7
	Structure Only Saved—Equipments, Furniture, Fittings, etc., Burnt—Available by Repair and Reequipment	7	Reinforced Concrete
	Available by Reinforcing, though Seriously Damaged—Equip- ments Not Burnt	1	Reinforced Concrete
	Available by Repairing—Equipments Not Burnt	4	Reinforced Concrete
Yokohama	Wrecked almost Completely and Burnt	1	Brick Work
	Structure Only Saved—Equipments, Furniture, Fittings, etc., Burnt—Available by Repairing	1	Reinforced Concrete
	Available by Repairing—Structure Only Saved	1	Reinforced Concrete

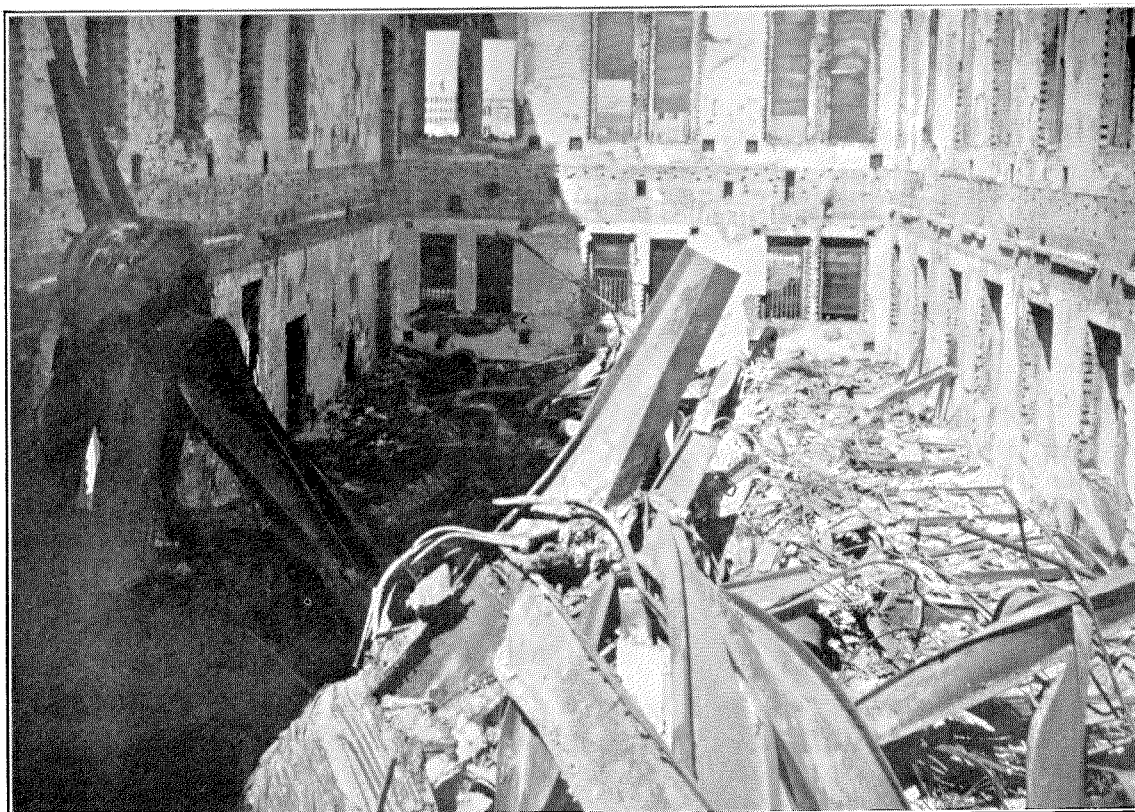

Figure 7—Ruins Inside Telephone Central Kyobashi, Tokio, After Fire

Horidome and Asakusa, damages were comparatively slight and these might be used again by simple repairs. By the conflagrations which spread immediately after the quake all these centrals lost all the equipments, furniture etc., the main structures of reinforced concrete alone being saved.

Thus all the centrals in Yokohama were shut down. In Tokio two centrals, Kudan and Yotsuya, were not burnt, but became unavail-

able; 14 of them burnt completely with their equipments; and only four remaining were capable of being opened to renew their service, namely Koishikawa, Ushigome, Awoyama and Takanawa.

(b) Damages to Office Equipments.

At the instant of the severe shock, some of the switchboards rocked backwards and forwards, cable runways dropped, M.D.F. and I.D.F. deformed in a corrugated way becoming

wavy, relay racks inclined, and meter batteries tumbled down. While these damaged parts were being investigated upon and restored as soon as possible in order to resume the service the fires started at nearly every part of the city, and spread out at a tremendous rate.

each case, some so slight as loosened bolts, disorder of relay adjustment and running over of electrolyte of storage batteries. These slight damages were present even in the cases denoted as "right" in table on following page showing the condition of damages in six surviving centrals.



Figure 8—Outside View of Building After Fire, in which were located two units of Telephone Central, Hamacho and Horidome, Tokio. Reinforced concrete building to be used again as Common Battery Office. Brick building to left is Central Naniwa

All the streets were crowded with refugees with their belongings, some escaping from the hand of fire, and others from the stifling smoke; all transportation facilities were stopped except a few automobiles. Chaotic condition which prevailed over the whole city was so terrible that it can not be expressed in words. While it was impossible at the time to investigate fully the extent of damages done to the equipments in each office, the six surviving centrals were investigated more fully. The nature of the disasters inside the burnt centrals may be noted in Figure 12. It should be remembered that the extent of the damage was different in

A description is given here of the condition of the batteries, which is applicable to all the centrals, and which is of interest in connection with improvement of setting in telephone offices. Damages to other kinds of equipment will be described later.

Electrolyte in cells ran over more or less in all the centrals. The glass type cells for register use (40^v) were arranged on two wooden frame shelves, upper and lower, and some of the cells on upper shelf fell down and were broken.

None of the cells of the common battery (24^v), which were in lead-lined wooden tanks, tumbled as they were set on the floor and were,

Equipment	Centrals		
	Koishikawa	Takanawa	Ushigome
Switchboard	Right	Slightly Shifted	Right
M.D.F. and I.D.F.	Slightly Inclined	Slightly Inclined	Right
Rack	Inclined	Slightly Inclined	Right
Register Rack	Right	Slightly Inclined	Right
Battery—24 volt	Right	Right	2 Cells Damaged
Battery—40 volt	Right	1 Cell Broken	Some on Upper Shelf Broken
Generating Equipment	Right	Right	Right

Equipment	Centrals		
	Yotsuya	Kudan	Awoyama
Switchboard	Line of Surface Shifted	Nearly the Same as Other	Right
M.D.F. and I.D.F.	Slightly Inclined	Centrals—All Equipments	Right
Rack	Slightly Bent	Here Were Dismantled	Right
Register Rack	Right	and Added to Other Cen-	Right
Battery—24 volt	3 Cells Damaged	trals	2 Cells Damaged
Battery—40 volt	Some on Upper Shelf Broken		Some on Upper Shelf Broken
Generating Equipment	Right		Right



Figure 9—Ruins of Cable Room After Fire in Telephone Central Hamacho, Tokio



Figure 10—Ruins of Cable Room After Fire in Telephone Central Horidome, Tokio



Figure 11—Ruins of Switching Room After Fire in Telephone Central Hamacho, Tokio

therefore, stable. Among damages done to the common batteries in the centrals, Yotsuya, Ushigome and Awoyama, the following may be mentioned: Ears of the active plates were melted as a consequence of short circuit, due to breaking of the supporting side glasses,

The difference in the condition of both instances above cited is probably due to the difference in the thickness of the supporting side glasses.

The generating equipments in all centrals were undamaged owing to the good foundations, especially so was this the case in Sumida cen-



Figure 12—Ruins of M. D. F. and Office Manhole After Fire in Telephone Centrals Hamacho and Horidome, Tokio

although they were of a standard size of secondary cell maker. In the case of two cells in Awoyama buckling of plates, which was occasioned by the falling of active materials, caused short circuit of the plates, thereby introducing a small hole in the lining of the tank, which led to running out of electrolyte. This hole, so small as not to be visible, seems to have been caused by sparks at a point where the active materials made a partial contact with the lead-lining. While the above batteries were of the G.S. type made in Japan, those in the centrals Takanawa and Koishikawa were of the Tudor type, and in the latter case there happened no such damage as mentioned above.

tral. As fire was not so serious there, 10 among 11 cells of common battery of that office were utilized again in another central by replacing some of the plates.

(c) Damages to the Subscribers Stations and Line Plants.

TOKIO

Facilities	Number Before Disaster	Burnt or Demolished	% Damaged
Subscribers' stations.	82,766	50,265	60.8
Poles.....	58,521	26,598	45.0
Arms.....	198,622	82,251	41.0
Aerial Cable			
(Cable Length)...	28,543 miles	12,299 miles	43.0
Pot Heads.....	4,897	2,927	60.0

YOKOHAMA

Facilities	Number Before Disaster	Burnt or Demolished	% Damaged
Subscribers' Stations.	10,340	9,740	94.0
Poles.....	13,350	12,600	90.0
Arms.....	24,700	21,600	88.0
Aerial Cable (Cable Length)...	104 miles	75 miles	72.0

The preceding tables show numerically the damages done to the subscribers' stations and line plants in both Tokio and Yokohama.

In both of the cities Tokio and Yokohama, most of the manholes were so deluged that it prevented a full inspection of damages done to the underground cables, but the following table gives the figures for cables which were penetrated by water through damages to the lead sheaths in the Tokio area.

Cable	Cable Length Unavailable In Miles	Cable Length Before Disaster In Miles
1200 pr.	.33	1.00
800 "	.05	.09
600 "	17.30	52.00
400 "	50.00	150.00
200 "	101.00	302.00
100 "	24.00	120.00

As the result of inspection of cables, the following faults on the cables terminating in five centrals were found:

Centrals	Total No. of Ccts. Prepared for Subcs.	No. of Und. Gr. Cables Terminated	No. of Faults Location on Und. Gr. Cable	No. of Faults Location on Aerial Cable
Koishikawa	9,000	27	0	50 pr.—15
Ushigome..	7,400	12	200 pr.—1 400 pr.—1	50 pr.—7
Awoyama...	4,800	11	0	0
Takanawa..	6,200	18	400 pr.—1	50 pr.—8
Yotsuya....	3,600	6	600 pr.—1	0

Damages to the cables in Yokohama are listed in the table shown in the next column.

As the description has been of a general character heretofore, a more detailed summary will be given below:

Toll lines: Among the damages done to the toll lines, it may be mentioned that the under-

ground toll cable between Tokio and Yokohama was so seriously damaged that it can hardly be repaired. This cable was installed in 1922 by the latest practice of engineering method. It is of the quadded type, medium heavy loaded, and was manufactured by the Western Electric Company in the United States of America, minute care being taken to minimize capacity unbalances not only between con-

Kind of Damage	Amount Damaged	Remark
Cable Length Burnt....	2.5 miles	Total cable length before disaster was 42 miles.
No. of Points of Punctured or Break.....	21	
No. of Cables Punctured or Broken.....	82	
No. of Locations Water Penetrated.....	273	
No. of Cable Pieces Water Penetrated.....	420	

ductors of the pairs but also between pair and pair. On its installation, cores were chosen and spliced, so as to minimize the capacity unbalances between each circuit, at seven points in each loading section. While this cable was installed with such extreme caution as above stated, it sustained from disaster such damages as the crushing of the cast iron conduit, sinking and shifting at the river Rokugo and other places along the route. Such painstaking labours during the cable laying was of no account, and a more minute investigation and electrical measurements will be necessary before it will again be available for the restoration of the service. The balancing at those faulty points will be more difficult than in the case of initial installation, because sufficient points can not be obtained to make the balance.

It is to be regretted that the scheme of replacing the present aerial toll lines between Tokio and Okayama (nearly 500 miles) by such quadded and loaded cables, with repeater stations enroute, will have to be postponed; as a part of this scheme, the cable working between Tokio and Odawara was in course of construction. The cable drums had been distributed along the route, so that they sustained heavy damages; while the loading coils were burnt completely, for they were in

course of testing in Yokohama. But it is desired to perform the above scheme as soon as the financial condition of the government admits.

Cables routed on bridges: Figures 14 and 15 show examples of the damages done to the

destruction of the embankments at both sides all conduits at points indicated by A and B in the figure and the lower layers of conduits at point C were broken, consequently cables kept their continuity merely by cores, lead sheath being peeled off as shown in Figure 15.

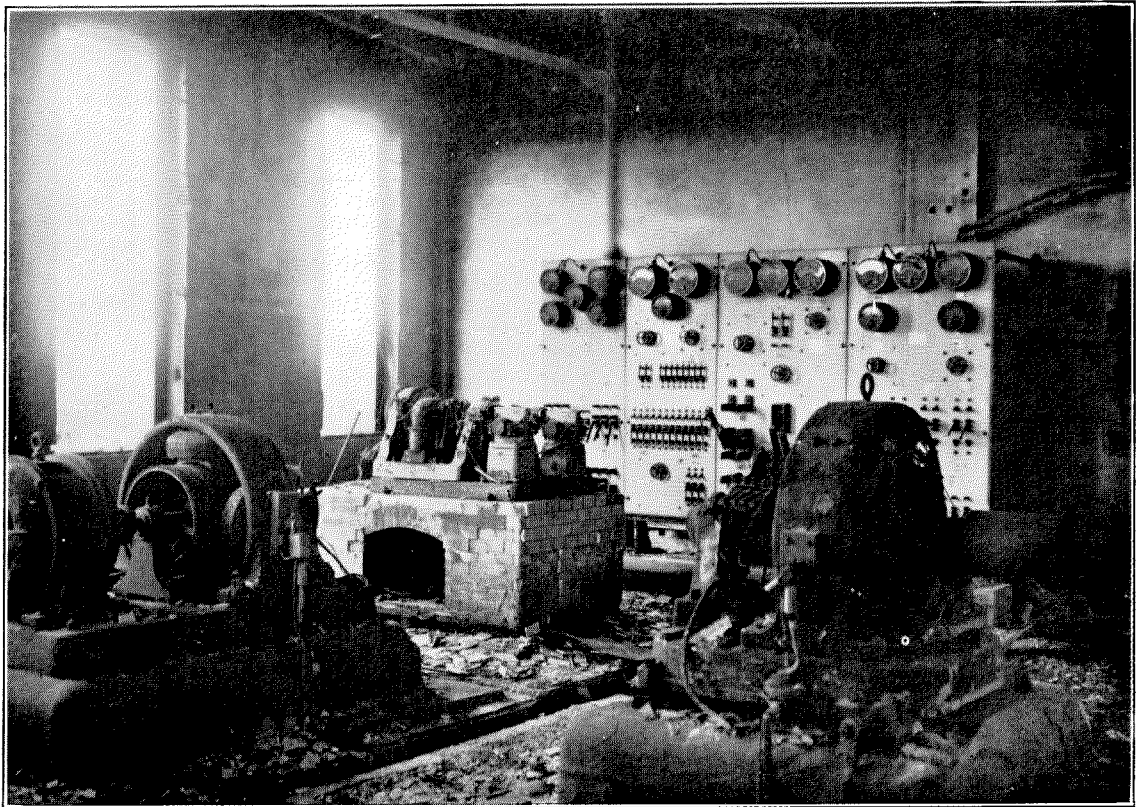
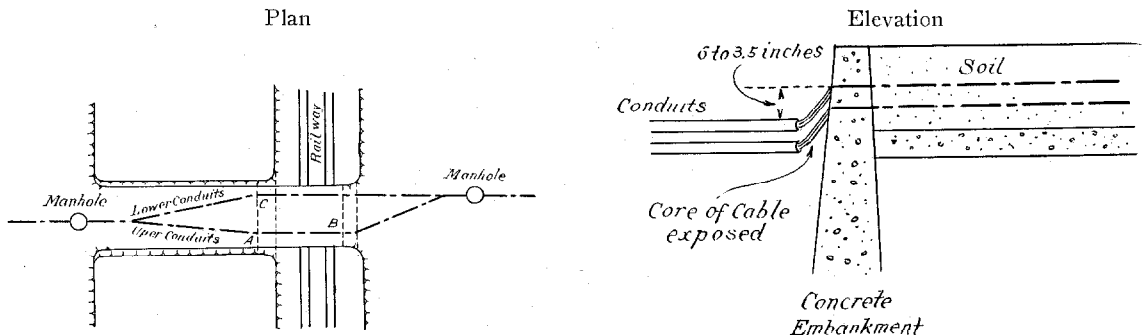

Figure 13—Ruins of Power Room After Fire in Telephone Central Sumida, Tokio

cables routed on public bridges in Tokio, which were found at a point crossing the government railway where underground cables were installed in conduits laid under the road. By the

This is caused by the shearing force on conduits, caused by the relative displacement between the embankment and concrete wall. Such shearing or crushing occurred at places where



Figures 14 and 15—Damages to Cables on Public Bridges, Tokio

soil and structures of different solidity meet together, for the wave motions in both were different.

Generally, in cases where cables were laid over public bridges or on special telephone cable bridges, it is a matter of course that these cables were burnt where the bridges were burnt, and even in case where the bridge

Cables in lateral tubes: In the burnt portion of the city a majority of cables in laterals were burnt and melted lead sheaths were stuck in the tube up to near the ground surface.

Manholes: In Tokio the majority of the damages in manholes were cracks in its walls due to horizontal quake. In Yokohama there were many cases where only a part of the

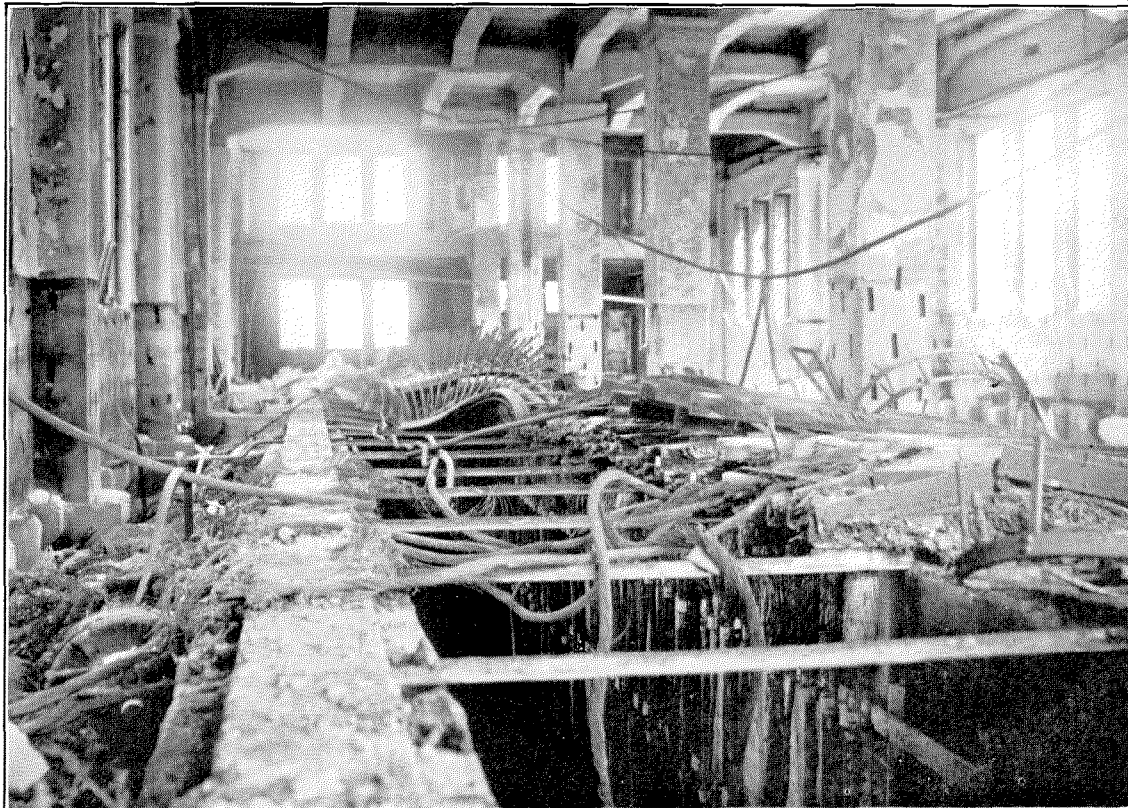

Figure 16—Ruins of M. D. F. and Office Manhole After Fire in Telephone Central Ginza, Tokio

itself escaped the fire, a majority of the cables were burnt by the conflagration of boats which crowded under the bridge for the purpose of getting shelter and escaping from the pouring flames and burnt ashes. In the case of concrete or stone bridges and special telephone cable bridges, which were far from the general public or not crowded by boats, cables were safe.

Office manholes: The office manholes were safe in centrals which escaped the fire, while in burnt centrals lead sheaths of cables were peeled off leaving mere cores as entangled ropes. A majority of manholes placed in front of centrals were undamaged in appearance.

manhole body itself was shifted horizontally, leaving the cover case projecting above the ground surface by one foot or so owing to sinking of the surrounding earth; the entrance arch was damaged and cast iron conduit projected by three feet or so towards inside of manholes. It is remarkable that there were no manholes which sank below the ground surface and this is probably due to the fact that the foundation was somewhat better than the surrounding earth.

Underground conduits near riverside: In the case of roads along the river bank the parts near the river became disturbed, consequently

underground conduits and manholes became exposed and cables damaged.

Open wires: Generally it seems that the damages done to the poles and open wires were most serious where the direction of the

each of 100 subscribers' capacity, installed in a room in the Tokio Central Post Office, which escaped the fire as referred to above; as a next step newspaper offices, banks and other subscribers having close relation with public



Figure 17—Manhole Near River Bank in Yokohama Remained Unsunken. Head of Manhole Projecting Above Road Surface

pole line coincided with that of the quake propagation.

Damages on toll lines were nearly the same as those of telegraph lines, the number of circuits damaged amounted to 303 terminating in Tokio, and 111 terminating in Yokohama.

2.—Emergency Measures

The following are the measures performed concerning telephones in consequence of the disaster:

(a) Local Exchanges.

In Tokio, for governmental offices pertaining to the temporary relief work and for other important subscribers, the service was opened by means of standard magneto switch boards,

interest were added as soon as the line plant, instruments and materials admitted. In Yokohama, since no building belonging to the Department of Communications had survived, a standard magneto switch board, with a capacity for 50 subscribers, was installed in the Branch Office of Public Works of the Department for Home Affairs, thus service was restored to governmental offices and important subscribers just as in Tokio. Later this equipment was removed to the barracks in front of Sakuragicho railway station.

(b) Toll Lines.

On September 3rd the toll circuits to Sendai and Utsunomiya were opened at Senju like telegraph lines and these were then cut over

to the standard magneto switch boards for the toll line purposes, which were installed in the Tokio Central Post Office at the same time the circuits to Nagoya, Osaka and other important cities were restored. As, owing to the inherent function of the standard magneto switch board, the toll service could not be given to the subscribers belonging to common battery offices, several pay stations were installed in the Tokio Central Post Office for the purpose of this service. Later, as the number of circuits increased, restriction for toll service was removed. Owing to shortage of the number of toll circuits, at first the toll service was afforded to messages relating to the relief business. On November 10th the total number of working circuits amounted to 74. Prior to this some modifications were given in order to give toll service to all subscribers in common battery offices.

In Yokohama, at first, the toll as well as telegraph service to Tokio was opened in the waiting room of the Kanagawa station of the interurban electric railway between Tokio and Yokohama, later removing it to the barracks above mentioned. The number of circuits to Osaka, Kobe, Nagoya and other important cities was nearly 10 on November 11th. As restoration of Yokohama was very slow, such number of circuits was sufficient for the toll service.

CHAPTER III.—RADIO TELEGRAPH AND TELEPHONE

1.—Damages done to Radio Stations

The number of radio offices within the area of the disaster is given in the table below, 6 among 20 stations being damaged most seriously:

Administration	Public	Private	Experimental	Total
Dept. of Communications.....	0	0	3 (3)	3 (3)
Naval Department....	—2—		1 (1)	3 (1)
Department of War...	0	1	1	2
Dept. of Railways...	0	0	1	1
Factory.....	0	0	4	4
School.....	0	0	4 (1)	4 (1)
Others.....	0	0	3 (1)	3 (1)
Grand Total....				20 (6)

Remarks: Figures in brackets denote totally damaged.

As seen in this table no station for public service was within the area of the disaster, but by means of installations in the military office and a few equipments which survived in the Communication Officers Training Institution, immediate emergency measures were performed even before the severe shock hardly slackened. Unfortunately the installation in that Institution was reduced to ashes by fire early the next morning excepting two iron towers.

The burnt out important offices, which have relation with radio engineering, are the Electrical Laboratory, Communication Officers Training Institution and Naval Technologic Research Section. As these possessed the most important laboratories and research equipments in our country, the loss which our Empire encountered is very great; for we have lost important research results, documents, reports, etc., together with equipments which were very important for the development of radio engineering, and also preparations for coming Conference on International Radio Communications.

It is reported that on September 1st, in the Communication Officers Training Institution only a few minutes before the great quake, the resonance condition of the receiving apparatus was exceedingly deranged, when some measurements for the radio communication from North-China were being investigated by the operator. Immediately after he had noticed this extraordinary phenomenon he felt the quake. Such a phenomenon might be caused sometimes by the swinging of the antenna, but the antenna in that institution was so tightly stretched that in ordinary heavy storms such a condition was never observed before. It is improbable that the operator was too earnest in inspection not to take notice of the first shock of the quake, because he felt the quake at the same time the others did. The quake in far distance might probably be mentioned as a cause for the above phenomenon, but the exact interval of time which elapsed between the first quake and the feeling of that phenomenon was not observed; so this phenomenon is cited as an instance toward solving the question to be met in the future. It may be added here that in that institution after

the quake listening was continued till next early morning when that building was burnt.

Soon after the fire a temporary circuit between the temporary Tokio Central Telegraph Office and the Telegraph Corps at Nakano was established; so that by means of the radio installation at the latter place, communication

the measures which were taken in the environs of the Tokio Central Telegraph Office, many of the radio stations in local districts took an active part in the communication service. The news of the great disaster of September 1st was received in Hong Kong and Manila on that day via Osezaki, which was sent from Choshi



Figure 18—Disaster of Pole Line Near Hakone. Longer Poles are for Power and Lighting. Smaller Ones for Telephone

was begun to all coast stations from Tokio. It is said that in this performance in the Telegraph Corps, portable radio apparatus proved a great success.

After September 2d, as communication between warships, which were anchored at Yokohama or Shibaura (in Tokio), and land stations increased, their interference in Tokio Bay became fairly strong. Beside the above, Funabashi Radio Station was successfully used for service. The network of radio communications for the public after the disaster is shown in Figure 19 schematically.

While the above is a general description of

and Iwagi, and on the other hand reports were sent from Iwagi directly to the United States of America and Hawaii, so that all the ships at sea listened in to these messages. Furthermore, the Iwagi station continued to send reports to America telling the conditions of Japan and translating news successively. This station contributed to a great extent in arousing in America and Europe profound sympathy for Japan, and it is especially rejoicing to note that the master and the officers of Iwagi station were publicly recognized in America. It must be mentioned here that the ship station on board the Koreyamaru and Mishimamaru,

which lay anchored at Yokohama, served to communicate with every quarter of the Empire, day and night on and after September 1st; also all the coast stations endeavoured to serve in a state of keepless and unresting condition for a fortnight. It is also reported that the Ohi factory belonging to the Department of

offices above mentioned were located very important laboratory installations, containing therein reports of research, documents and materials for investigations relating to wired and wireless telegraphy and telephony in this country, which had been prepared by many engineers who spent many years, some in foreign countries gathering valuable reports and papers, and others at home working most pains-takingly at their chosen profession. It is to be greatly regretted that these precious documents and installations were reduced to ashes and that nothing can compensate for the loss which can not be estimated in terms of monetary value.

The disaster caused not only much inconvenience in the preparation of papers for the Technical Committee on International Radio Communications, but also it introduced great obstructions for the telegraph and telephone extension plants to be performed in future, which are being proceeded with upon a plan laid out for a number of consecutive years.

While much stock material was in store for emergency purposes much of it was lost by the conflagration, causing great obstructions to emergency measures. On the other hand, much difficulty was encountered as the more important business and factory quarters of the city were wiped out.

CHAPTER V.—LESSONS LEARNED FROM THE LATE DISASTER

A few instances regarding information about telegraph and telephone installations will be added below, as such results of investigation of the damages caused are of some value toward preventing such disasters in future.

1.—*Office buildings:* It would be very important as well as interesting to architects to investigate the condition of buildings which escaped the damages of the quake and came comparatively unharmed through the fire. Quake and fire proof structures are to be recommended for houses in all the important parts of the city, especially for telegraph and telephone offices. Telegraph and telephone installations are urgently required in times of such disasters, and much thought should be given to selection of proper types to be adopted for

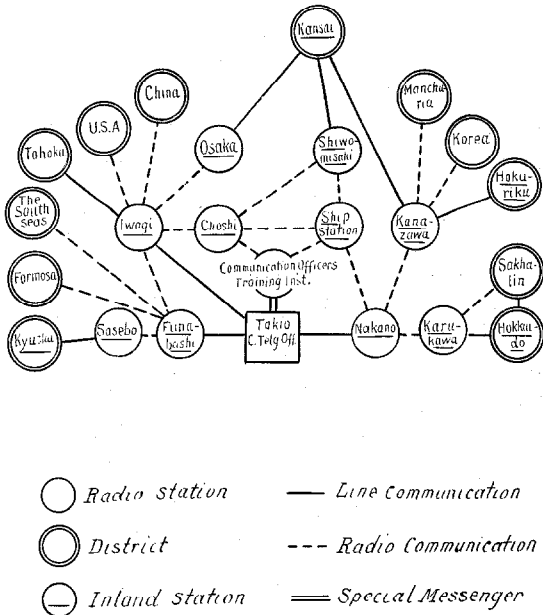

Figure 19—Schematic of Radio Communications After the Disaster

Railways, and being one of the experimental stations, served to communicate with ferry-boats that ran between Tokio and Shimizu.

The great difficulty encountered in connection with radio communication was confusion as stated above, but this was restricted to the Tokio Bay, and by order it was practically overcome by means of proper adjustment of the wave lengths.

CHAPTER IV.—DAMAGE DONE TO LABORATORY INSTALLATION, MATERIALS FOR INVESTIGATION AND STOCKS

Material or immaterial losses beside those previously mentioned were sustained from damages occasioned to the buildings of the Department of Communications, Electrical Laboratory and Technical Section of the Tokio Administrative Office as well as store-houses which were completely burnt. In these three

these buildings. While most of the brick structures became dangerously shaken by the earthquake, reinforced concrete buildings were immune to both the earthquake and fire. In Tokio, for instance, the building of the toll and two local exchanges at Marunouchi was destroyed by the fire with all the contents except mere structures, so that the building is being refitted for the purpose of establishing a temporary toll exchange, and housing the Tokio Central Telegraph Office and one of the local exchanges. Beside this, the buildings of the centrals Ginza, Asakusa, Hamacho, Horidome and Sumida may also be utilized again by simply repairing the inside fittings. From the above it is evident that reinforced concrete building should be adopted in all cases in future.

By the first shock of the quake all water mains were interrupted, so that fires at almost every part of Tokio and also of Yokohama got immediate headway at their will and nearly all important parts of Tokio and the whole of Yokohama were turned into ashes. Temperature of the burning areas reached such high degree that window and other glasses and some metal parts melted as if in hearths and it is also to be noted that metal fire-shutters in all the buildings worked ineffectively. In future, much precaution must be taken in fireproofing windows, which seem to be the weakest point of buildings. Strong cyclones and high winds were caused by local temperature differences during the fires. Some people were blown upwards and carried to places some distance away. It is difficult to say what unexpected events happened during those few days. It is needless to say that all such questions must be taken into consideration by engineers who are to shoulder the responsible work of reconstruction and all measures for fire and quake proofing should undoubtedly be provided for.

2.—*Construction of lines:* In the burnt up areas the overhead telephone lines were completely destroyed by fire, though a majority of them were replaced by underground system long since. These overhead lines being for distribution purpose for subscribers, it is desirable to replace them by an underground

system, if financial conditions will permit this to be done in the near future. As given in a table previously referred to, damages to the underground cables were rather slight, much less when compared with aerial lines, even in the cases where manholes became flooded by water, or cast iron conduits projected into the manholes due to destruction of road and crushing of conduit. From the point of view of beauty and also for reasons of frequent faults in aerial lines, it would be advisable to put the whole system underground in both Tokio and Yokohama.

3.—*Construction of underground lines:* A majority of manholes were flooded by drain due to loosened connections and breakages of conduits. In future, special attention should be paid to workmanship of jointing the conduits and uniformity of foundation beds along the entire underground construction.

4.—*River crossing:* For routing cables over public bridges it is safer to choose bridges of fireproof construction, such as concrete or stone work, and to wrap them with some fireproof material. It is preferable to wrap cables with fireproof substance even where special telephone cable bridges are used or to install them under river bed. In the late disaster some cables, which were otherwise undamaged, were damaged at river crossings, which caused delay in reopening the telephone service to some extent. It would be very interesting as well as instructive to investigate methods of river crossing of cables.

5.—*Supply of equipments and materials:* The most difficult problem encountered in making arrangements for emergency measures was the requisition of instruments and materials. Stocks of instruments and materials, which were lost by the disaster, amounted to an enormous quantity, and because many of the factories were also damaged, their supply was obtained partly from local makers, while some was imported.

6.—*Adoption of automatic telephone system:* It is true that civilization tends to replace the manual power by the mechanical. Though it is also clear that, in case of telephone service, to use a great many operators is both un-

economical and inconvenient, owing to financial reasons the adoption of the machine switching system has not yet been realized. It is firmly believed that this is the best opportunity to replace the former inconvenient telephone by a more up-to-date and convenient automatic system, as both Tokio and Yokohama are now deprived of telephone service almost entirely.

7.—*Installation of radio telegraph and telephone:* At the time of the late disaster there were no public radio stations in the burnt up area, which catered to the public service, and consequently no radio station was damaged; but if there had existed an undamaged one we can easily imagine its possible activity. It would have been a foregone requirement that an uninterrupted supply of electric power and a continuous communication between it and the central office were firmly established.

It is to be noted that in the last disaster the entire system of the electric power supply and lighting were interrupted for some time. From these observations it is evident that such installations should be made fire and quake proof, and that interconnections between power houses and transformer stations, between these points and consumers, etc., should be of the underground system.

Broadcasting of radio telegraph served admirably in reporting the disaster to foreign countries as well as to ships at sea. It is firmly believed that telephone broadcasting would have played an efficient part if it had existed, a good reason for its realization.

8.—*Store-houses:* It is believed that store-houses in future should be not only as rigid in construction as other buildings (or rather more so) but also fireproof, as much difficulty was experienced in executing emergency measures at this time. It is safer not to centralize store-houses, but to distribute them in many quarters of the city, in spite of some inconveniences to be felt in ordinary days from the point of view of storing, shipment and supervision. At the late disaster, for instance, the store house at Shibaura remained undamaged while that in the enclosure of the Department of Communications was burnt. It is worth while to consider this problem.

APPENDIX

Outline of the Programme of Reconstruction Executed and Otherwise. (March 1, 1924)

CHAPTER I.—TELEGRAPH

1.—Tokio

As a consequence of the removal of restrictions for messages, as above mentioned, the volume of traffic increased tremendously. The number of circuits was increased to 76 in Eiraku building which was the full capacity of that temporary office. On November 23rd this temporary office was removed to the repaired building in which the local telephone exchange Marunouchi was located. At that time some suburban circuits were added. The traffic carrying capacity of the circuits has been restored since December 12th to that of as nearly as before the disaster, being increased by 160; while some circuits for city branch offices could not be restored owing to the delay in reconstruction of buildings. At the end of the year 1923 circuits were classified as follows;

System	Number of Circuits
Automatic Duplex.....	24
Sounder Duplex.....	58
Sounder Simplex.....	144
Morse Duplex.....	3
Morse Simplex.....	14
Siphon Recorder Simplex.....	1
Telephone.....	1
Total.....	245

With the addition of 11 circuits in January 1924, nearly all circuits were restored to their former capacity with the exception of local circuits in the city. These city circuits will be opened as soon as switch board and other equipments as well as office accommodations are ready.

As far as the number of circuits is concerned, restoration will be accomplished by April 1924, while complete reconstruction will be finished early in the year 1925. At that time the Tokio Central Telegraph Office will be removed to its new building which was in course of construction before the disaster.

The pneumatic tubes in Tokio had been installed between the Tokio Central Telegraph Office and eight branch offices with a route mileage of nearly 6. But all the terminals were burnt by fire and the underground tubes damaged also. The present scheme of reconstruction is to connect the first four branch offices with the central when the permanent office is opened; making a route mileage of 3.5. Successively for 13 branch offices, a mileage of 20 in the year 1925, and for four branch offices

to the new building. These circuits may be classified as follows:

System	Number of Circuits
Automatic Duplex.....	1
Sounder Duplex.....	8
Sounder Simplex.....	28
Morse Simplex.....	2
Total.....	39

Complete restoration will be accomplished in April, 1924.



Figure 20—New Tokio Central Telegraph Office After Fire. In Course of Construction

a mileage of 8.5 in the year 1926 will be added connecting with the central office respectively.

2.—*Yokohama*

As previously described, 19 circuits were restored by the emergency measures in the temporary office at Sakuragicho, while at the end of November these were increased to 26. 39 circuits were totally restored in the first part of January 1924, the office being removed

CHAPTER II.—TELEPHONE

1.—*Tokio*

(a) Exchanges.

Prior to the disaster, in Tokio, there were one toll and 19 local exchanges, serving about 83,000 telephone stations. Among them the toll, 15 local exchanges and nearly 52,000 stations were burnt or wrecked by the disaster. An area of 13.5 square miles in the city of Tokio was burnt to the ground, 30.5 square

miles being the total area. The remaining centrals were reopened on September 29th, after urgent repairs to office equipment and line plant. The number of stations in those four centrals are given below:

NUMBER OF STATIONS

Central	Before Disaster	Burnt or Wrecked	Opened on Sept. 29
Awoyama.....	2,416	0	2,416
Koishikawa.....	6,836	699	6,137
Ushigome.....	4,172	0	4,172
Takanawa.....	4,473	125	4,348
Total.....	17,897	824	17,073

Since the localities which are covered by the above centrals are situated on more or less hard bed ground, damages to them were comparatively slight.

It is of interest to give a brief description about the traffic data on telephone service during the first three days after reopening the four centrals. The average number of calls per station per day was 2.5, while 8.5 was the average during last August, just before the disaster.

Immediately after the above centrals were reopened efforts were made to connect those subscribers who were most urgently in need of telephone service, and who were scattered over all quarters of the city, to any one of the above four centrals according to their locations, by the aid of inter-office trunk lines. Thus a total of 20,743 stations were restored by the end of the year 1923. The temporary local exchange Ôte was opened with a capacity of 4000 in the burnt building of central Marunouchi. By the end of March the central Yotsuya will be reopened, after repairs to that building are accomplished. Thus, a total of 30,000 stations will be restored. By the extension of the switch boards in the above six offices, 9,000 stations will be added by the end of August.

Two of the four burnt offices, the buildings of which are in course of repairs, will be reopened in the fall of 1924 and the other two by February 1925, the common battery system being employed. By March 1925, the total sum of stations restored will be enumerated by 64,100, there being 83,000 before the disaster.

Besides the total of 10 exchanges, thus restored, four and five automatic exchanges will be opened by the end of fiscal year of 1924 and 1925 respectively; one of them being planned to supplant the temporary common battery office Ôte. Restoring of the remaining 19,000 stations in Tokio will be accomplished at the same time.

The programme of measures for telephone reconstruction is expected to extend for a period of 2½ years, rather longer than usually accepted. In justification to the length of the reconstruction period it might be mentioned as follows. It is, of course, true that restoration of telephone service should be done as quickly as possible, as it is one of the most essential for reconstruction of Tokio. On the other hand, it may easily be justified that the work of reconstruction of the multi-office telephone area, which has stations numbering more than 80,000, can not be treated as simply as the case of several independent telephone areas of moderate capacity. For the preparation of switch boards, first of all, a great difficulty is encountered. As several of the factories for telephone industry were damaged it must be expected that a rather longer delivery for home made is inevitable. Many foreign makers also offered earnest suggestions for the restoration of telephone system, but they could not supply switch boards of the specified type at the specified time of delivery. To adopt many different systems of switchboards in the present case in Tokio, must be carefully considered, from the point of view of inconvenience and want of economy in operation and maintenance.

On the other hand, security of service can not be expected if telephone offices were installed in imperfect buildings like barracks. Moreover, owing to probable alterations in the street contours, as a consequence of the city's reconstruction planning, construction of permanent buildings is not allowed before that plan is settled. To build offices with risk of removal within two or three years, can not be thought of. It is thought not unlikely that a total of 30,000 stations can be restored by March, 1924, and 64,000 by March, 1925. With this number it is expected that a restoration of service to all subscribers, at

least one substitution for each subscriber, and also a fairly ample service may be given in Tokio, the condition of general business being depressed to some extent compared with that before the disaster. A careful investigation regarding every point leads to the conclusion to adopt the programme of telephone reconstruction outlined as above.

(b) Toll line.

After the emergency measures, as previously mentioned, were taken on December 1st, 1923, the temporary toll office was removed to the repaired building of the old Marunouchi, where equipments were provided for 164 circuits. The number of toll lines will be increased to 277 by the end of March, 1924, and it will not be so long before all circuits, 317, will be restored; while in the fall of 1925 the permanent toll exchange will be opened.

2.—*Yokohama*

(a) Local exchange.

While there were in Yokohama one toll and two local exchanges, serving 10,600 stations,

the whole was practically destroyed. On September 29th, 1923, 30 subscribers were restored and this increased to 450 by the end of that year. It is planned to restore 2,000 stations in the new temporary office by March 1924, the switch board being of the magneto parallel multiple type removed from a central which was recently closed in Tokio; by June 1924 the sum of stations will increase to 3700. In the fall of 1925 two automatic exchanges will be opened, where all the subscribers will be cut over and all the remaining stations will be restored at the same time.

(b) Toll line.

The number of toll lines in Yokohama before the disaster was 111. Gradually increasing the number of line restored, a total of 35 were completed at the end of the year 1923. The sum of restored lines will become 73 by the end of 1924 and 111 by 1925; thus making all restored.

It must be added that when the automatic system supplants the manual local exchange the permanent toll office will be opened.

The Restoration of the Works of the Nippon Electric Company, Ltd.

By A. G. JILLARD

General Manufacturing Advisor, Nippon Electric Company

WHEN the devastating earthquake occurred on September 1st of last year the plant of the Nippon Electric Company, Ltd., included 293,750 square feet of floor area; approximately 185,750 square feet of this being in five modern, reinforced concrete buildings. Four of these buildings were three stories high while the fifth was partly two stories and partly three stories. The remainder of the buildings were of brick construction, one, two and three stories high.

The earthquake resulted in very serious damage to the concrete buildings, consisting in general of a failure of the columns of the second and third floors; the roofs and third floors dropping to the second floors. In some places the second floor failed and dropped to the ground floor and part of the side wall of the first floor of the two story building was badly shattered. The brick buildings suffered considerable damage in the way of cracked and broken walls but they did not fall and their occupants and contents were unharmed.

The concrete buildings were occupied almost entirely by the Manufacturing Branch and they represented about 73 per cent. of the area of that Branch.

How badly the Manufacturing Branch was crippled and the magnitude of the task of rehabilitation involved may be realized from the fact that, Punch Press, Milling, Drilling, Screw Machine and Lathe, Metal Finishing, Wood Working, Meter, Receiver and Transmitter Assembly, Switchboard Assembly, General Assembly, and Tool Making Departments, with their associated inspection groups and store rooms were all in the wrecked buildings, as were the Engineering and Drafting Departments and the Manufacturing Department Office.

Fortunately the plant was not reached by the fires which swept over about 60 per cent. of the city and the losses, though high, were not

nearly so great as they might have been. The principal items of property loss were:

Buildings.....	Yen 790,685
Machinery, Permanent Fixtures, etc.....	385,557
Material, Parts and Merchandise.....	244,582
Merchandise awaiting acceptance destroyed by fire at Government compounds.....	251,519

The demolition of the wrecked portions of the buildings and the salvaging of materials, parts, apparatus and machines were started simultaneously on the seventh day after the quake, the wrecking work being done by an outside contractor and the salvaging by company employees.

Machines, benches, stock racks, etc., supported the wreckage to a certain extent and formed many pockets access to which was gained by cutting holes in the floors and into which men crawled on hands and knees, passing parts and apparatus from hand to hand to improvised chutes to the ground. From the chutes the recovered parts and apparatus were transported to temporary sheds or to the less damaged buildings where other employees were at work sorting, cleaning, dismantling and repacking. At the same time accessible machines, many of which had to be partly dismantled to clear them of the wreckage, were lowered through holes cut in the floors and were taken to the other buildings where they were completely dismantled and cleaned. Undamaged machines were then reassembled while the damaged ones were classified according to the extent of the repairs required and partly reassembled or stored in their dismantled state as the circumstances warranted. As the wreckage afforded but little protection from the many heavy rains which occurred with unusual frequency for weeks after the quake, it was necessary to remove nearly all of machines and stock from the ground floor of the wrecked buildings.

All wrecking was completed in three months and during that period the contractor furnished

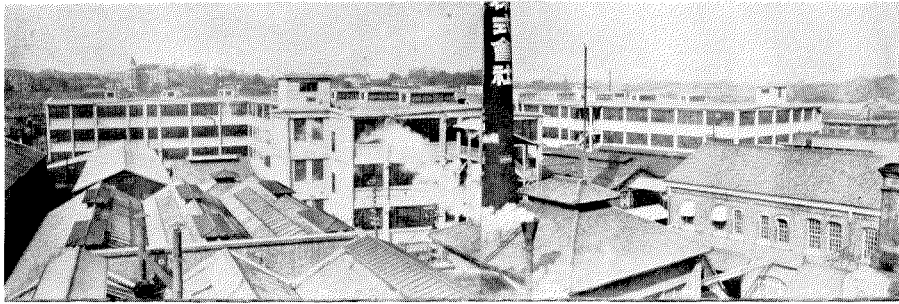

The concrete buildings as they looked before the quake



The concrete buildings as they looked just after the quake

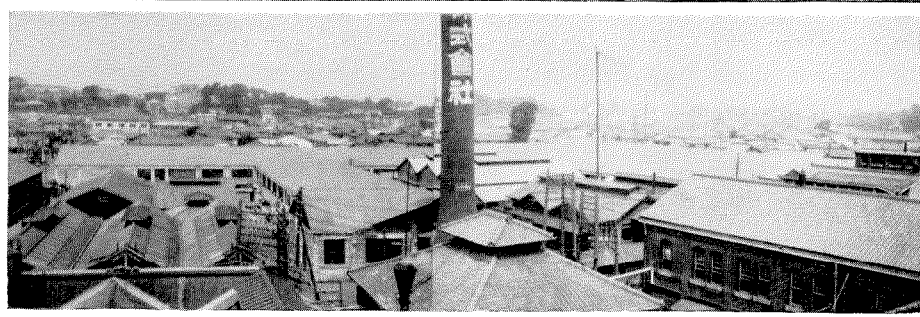

As the concrete buildings look today



24,581 man days of labor. For a part of the time four hundred and fifty men were employed on wrecking work. 3,536 labor days with horse wagons and 116 labor days with motor trucks were spent in removing the debris.

Had the problem been merely to salvage and repair what could be recovered from the wrecked buildings it would have been amply difficult, but as the salvage was being crowded into the other buildings, it was at the same time necessary to prepare for the resumption of manufacturing, and unit by unit as they were required, emergency installations of metal finishing equipment, tool making equipment, automatic and hand screw machines, wood working machines, punch presses, milling machines, drill presses, etc., were set up wherever space could be provided. Machines in the brick buildings which could be spared temporarily were taken down and stored in close formation, aisles were narrowed or temporarily eliminated and piece parts were stored in the lumber drying kilns to provide the space required.

Thirty-four days after the quake the Manufacturing Branch began delivering fully repaired apparatus which had been completely assembled before the quake but injured in the wreck and three weeks later resumed regular work on No. 92 Jacks, making a delivery on November 5th. Other jobs were resumed in rapid succession; deliveries of No. 12 Protectors being made on November 13th, Extension Sets on November 16th, and Keys on November 28th.

By the end of the fifteenth week all departments which had been in the wrecked buildings had resumed regular production work in temporary locations and repairing of buildings was well under way.

The concrete buildings were demolished to the level of the second floor and proper repairs made to the remainder. Trusses of light poles were erected on the second floor and covered with galvanized iron, the result being one story buildings with a garret available for the storage of certain classes of materials. None of the

second floor is available for anything other than storage.

While wrecking and repairs were being carried on, the space which would be available was reallocated, a new block plan layout was made of the entire Manufacturing Branch and detailed layouts of all departments were made in accordance with this plan. As repairs to the buildings progressed, the departments were re-installed according to the new layouts. This work was completed and the entire Manufacturing Branch was running at full capacity by the 1st. of June, 1924.

In spite of their handicap, the Nippon Electric Company secured the orders for the greater part of the telephone equipment purchased or contracted for by the Department of Communications and the Department of Railways since the disaster and to the end of June, 1924. Of the orders secured, 79 per cent. consisted of equipment not manufactured by the Nippon Electric Company but which will be supplied by its affiliated companies, 18 per cent. consisted of equipment to be manufactured and 3 per cent. was supplied from Merchandise Stock.

Plans for the future include the demolition of all buildings now on the compound and the erection of eleven steel frame buildings, each three stories high. These buildings will provide a total gross floor area of 370,000 square feet. By roofing over the first floor in the light courts the percentage of first floor area will be increased sufficiently to permit of the installation of nearly all machine equipment on the ground floor, reducing the loads above the ground floor and thus decreasing the danger of damage from earthquakes. On the sides and rear of the compound the public streets are narrow and here the buildings will be located far enough from the property lines to provide amply wide safety zones in case of fires near by. The plans also include the installation of a complete sprinkler system.

Detailed drawings and specifications for the first new building are completed and work will be started during August of this year.

The Stethophone

By H. F. DODGE

Engineering Department, Western Electric Company, Inc.

FOR the investigation of pathological conditions of the heart and chest, the physician relies in large measure upon the process known as auscultation, or listening to the sounds produced within the body. The instrument ordinarily employed for this purpose is the familiar stethoscope, an acoustic device for picking up the body sounds and conducting them through rubber tubes to the ears. The experience of the physician then

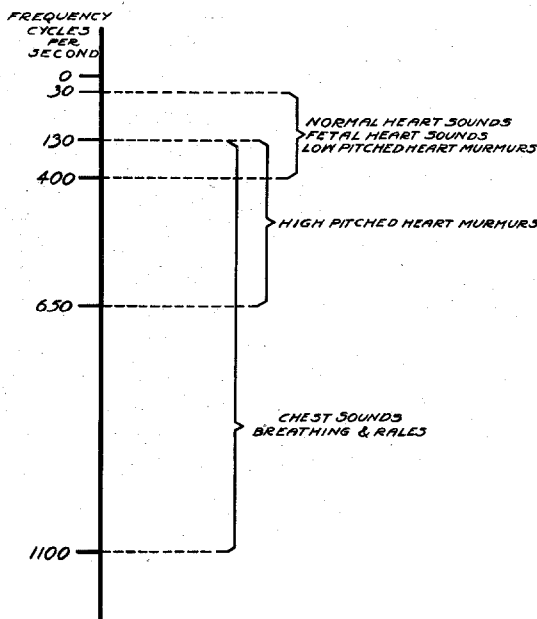

Figure 1—Frequencies of Body Sounds of Interest in Auscultation as Determined With the Stethophone

enables him to determine whether the sounds are entirely normal or whether they are indicative of any of a considerable number of abnormal conditions.

Such an acoustic device for listening to very faint sounds is necessarily subject to certain limitations. It is essentially individual. In consultation and in instruction in medical schools, it is necessary for each observer to listen separately. Moreover, some of the important sounds such as the heart beats of an unborn child can only be heard under favorable conditions and by physicians whose hearing is

exceptionally acute. Another disadvantage of the ordinary acoustic stethoscope is its inability to eliminate sounds to which it is not desired to listen so that the physician is forced to pick out the sounds of interest from the general conglomeration of sounds which reach his ear. The benefits possible of realization if these sounds could be intensified and other sounds cut out have long been recognized. Recent progress in the development of vacuum tube amplifiers and of electric filters indicated that it might be possible to combine these to serve the purpose.

With this end in view, development work was undertaken by the scientists of the Research Laboratories of the American Telephone and Telegraph Company and Western Electric Company, Inc., at the urgent request and with the active cooperation of Dr. H. B. Williams of the College of Physicians and Surgeons, New York, Dr. Richard C. Cabot¹ of the Massachusetts General Hospital, Boston, and Dr. C. J. Gamble² of the School of Medicine of the University of Pennsylvania, Philadelphia. The cooperation of these physicians permitted the instrument to be given practical tests at every stage of its development and to embody in its design ideas which could be obtained only by actual experience. The instrument was first employed for instruction purposes in the classes of Dr. Cabot. It was in these classes that the field of usefulness of the instrument for teaching purposes was explored and suitable wiring arrangements for auditoriums worked out. This cooperative development work has resulted in a practical multiple electrical stethoscope which has been named the "Stethophone."

The first step in the development work which produced the stethophone was a careful study

¹ Cabot, R. C.: "A Multiple Electrical Stethoscope for Teaching Purposes," *J. A. M. A.*, July 28, 1923, pp. 298, 299. "The Need for Protecting Patients from the Pedagogic Enthusiasm of Medical Teachers," *The Survey*, February 1, 1924, p. 453.

² Gamble, C. J. and Replogle, D. E.: "A Multiple Electrical Stethoscope for Teaching," *J. A. M. A.*, February 2, 1924, Vol. 82, pp. 387, 388.

of the various sounds of interest in auscultation. By means of electrical filters which have been developed in these laboratories to the point where practically complete control of frequencies has been obtained, the frequency ranges of importance in normal heart sounds, fetal heart sounds, low-pitched and high-pitched murmurs, breathing sounds and rales were determined. It was found that practically all of these sounds were made up of frequencies below 1,100 cycles per second and that certain general classes of

This task completed, there remained that of developing an amplifier of quality high enough to transmit sounds undistorted to the ears of the observer and of power sufficient to intensify these sounds to the point of raising the audibility of the faintest ones sufficiently to provide comfortable hearing and to permit of increasing the number of observers to several hundred, when desired. Besides the amplifier it was necessary to develop a high quality detector or transmitter for picking up the body sound

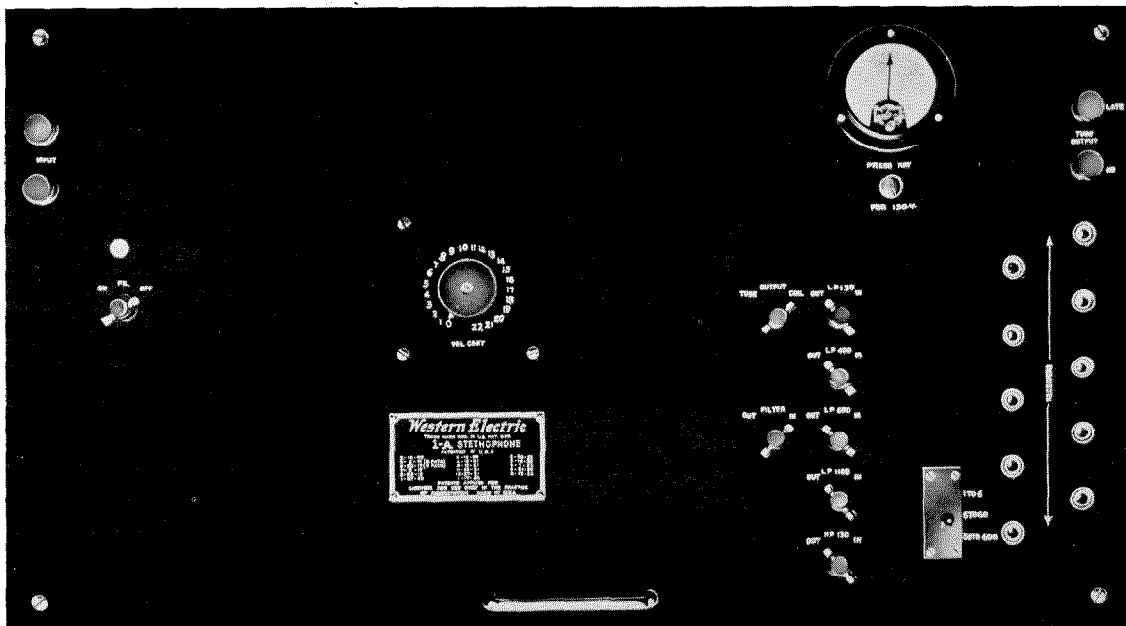

Figure 2—No. 1-A Stethophone—Panel View

sounds could be relegated to fairly definite bands of frequencies. Figure 1 gives a rather broad picture of this classification. For individual cases the frequency bands of immediate interest are often considerably narrower than shown. Compared with the frequencies of which speech sounds are composed, low frequencies alone were found to be of importance in auscultation. After the study of body sounds had been completed, the knowledge gained was employed to develop a set of electrical filters which would bring out more clearly the body sounds of immediate interest in certain frequency regions by suppressing all other sounds made up of frequencies outside of these bands.

vibrations and a sensitive receiver to deliver the amplified sounds to the ears of the observer or observers. After the different parts of the apparatus had been developed further work was necessary to combine these in an instrument convenient in size, simple in operation and easy to maintain.

In its present form the stethophone consists of four essential parts, an electro-magnetic contact transmitter, a high quality amplifier, a group of electrical filters and a number of output receivers for individual observers. All of the above apparatus is conveniently assembled in a portable cabinet about the size and shape of a tea-wagon, and like a tea-wagon capable of being easily rolled from place to place. The 6-volt

storage battery and the 130-volt "B" battery required for the operation of the amplifier are contained in the cabinet. The cabinet provides, in addition, a compartment for storing the receivers, transmitter, vacuum tubes, etc. The control switches for the stethophone are located in the horizontal panel which forms the top of the cabinet. This panel is protected by a removable cover.

The contact transmitter developed for the stethophone has been so designed as to provide efficient transfer of vibrational energy from the flesh of the body to the amplifier and at the

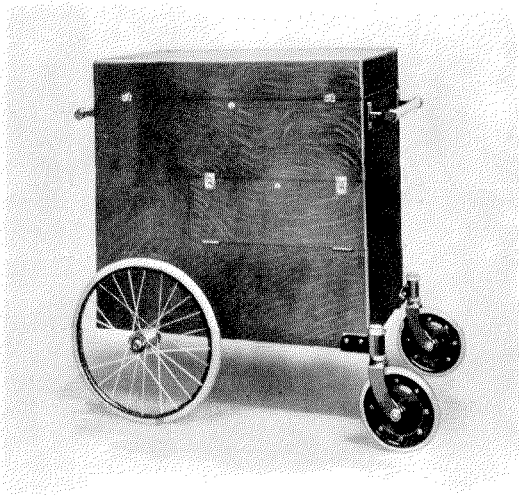

Figure 3—No. 1-A Stethophone Closed

same time to be inefficient to sound waves in the air, thus reducing to a minimum the amount of room noise introduced into the stethophone circuit. On account of its good frequency characteristic, the transmission of body sounds is accomplished with less distortion than is produced by acoustic stethoscopes. The introduction of noises due to friction of the transmitter cord on clothing or other surfaces has been effectively prevented by a cord of special construction.

The amplifier which serves the purpose of increasing the magnitude of the faint vibrations picked up by the transmitter is of the vacuum tube type and has three stages of amplification. The control of the volume of output of the amplifier is obtained by means of a resistance potentiometer inserted between the first and

second stages. This amplifier gives a practically flat characteristic for all frequencies between 40 cycles and 5,000 cycles. It is capable of amplifying the input power from the transmitter 100,000,000 times. Since less than one one-thousandth part of this power is required to bring the sound intensity at the ears of one observer up to that obtainable with the ordinary stethoscope, it is seen that there is an enormous amount of reserve power available either for obtaining greater intensity of sound or for distributing this sound among a large number of individual listeners.

While employing the ordinary stethoscope, the physician is often annoyed by the presence of sounds other than those in which he is interested. For example, when studying a high-pitched heart murmur, he is compelled to listen also to the low frequency normal heart sounds which tend not only to distract his attention but also to mask the murmur which interests him. Conversely, he is often interested in low-pitched sounds which he must pick out from those of a higher pitch. To permit the study of particular sounds without interference from other sounds is the function of the electrical filter system of the stethophone.

Singly or in combination, the five filters of this system serve three purposes:—that of low pass filters, which pass only vibrations of frequencies below a certain cut-off frequency, high pass filters which pass only vibrations above a certain cut-off frequency and band pass filters which pass frequencies within a definite band between two certain cut-off frequencies, thereby permitting one to hear only the sounds within the band. The filters of the stethophone consist of one filter of the "high pass" type having a cut-off frequency of 130 cycles and four "low pass" filters having cut-off frequencies as follows: 130 cycles, 400 cycles, 650 cycles and 1,100 cycles.

By employing the high pass filter in combination with the low pass filters, a group of band pass filters is made available. By means of their simple switch control any of the filters can be instantaneously introduced or removed from the circuit thus providing the physician with means of listening with a maximum of clearness and a minimum of interference to any body sounds in which he is interested at the moment.

The low pass 130 cycles filter facilitates the study of normal or fetal heart sounds, when the rate alone is desired, by excluding common interfering noises including the sounds of the human voice. This filter, would, however also eliminate many heart murmurs. These can best be studied by using one of the low pass filters

130 cycles, the high pass 130 cycle filter is used to eliminate sounds of lower pitch. This filter has been found to be of use for many purposes. Very faint high-pitched murmurs are often masked or obscured by the loud normal heart sounds. By means of the high pass 130 cycle filter the normal heart sounds may be sup-

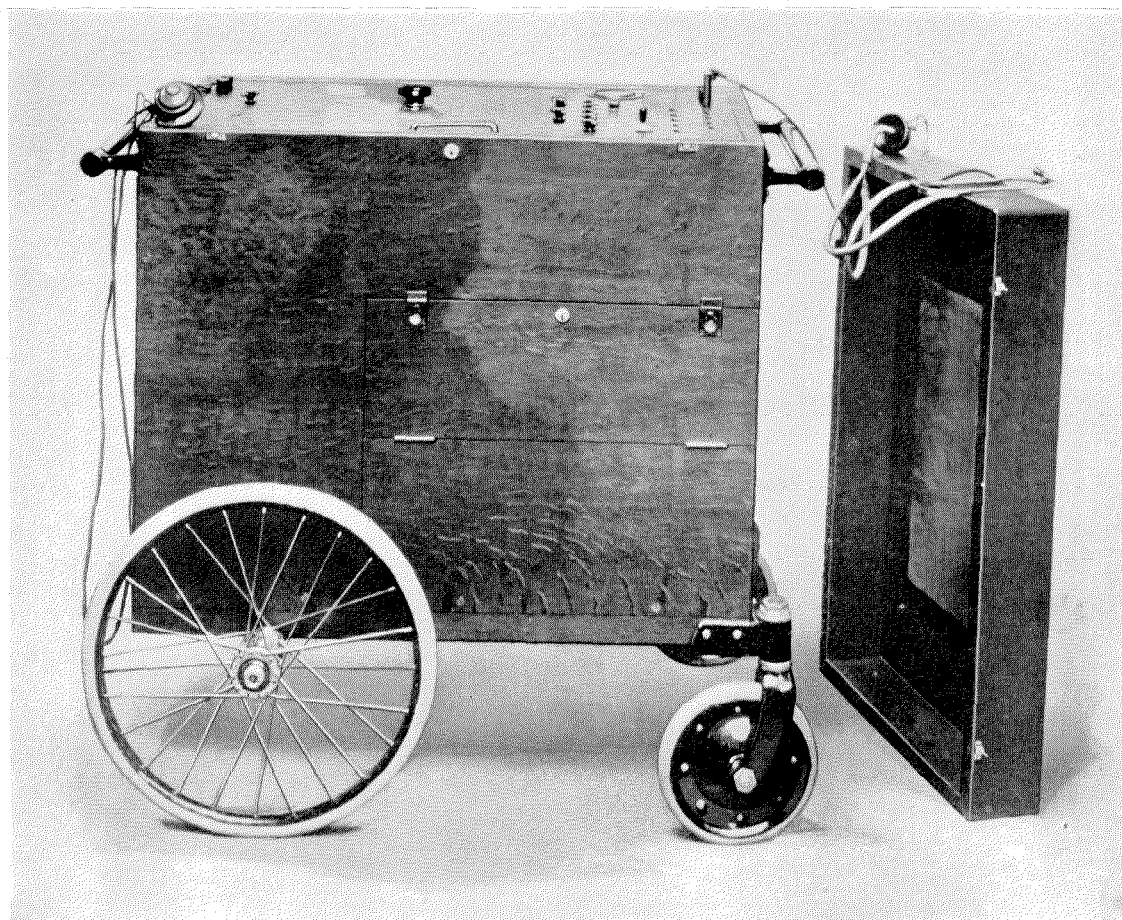

Figure 4—No. 1-A Stethophone—Cover Removed, Showing Panel and Control

with a higher cut-off frequency. Presystolic and low-pitched systolic and diastolic murmurs can usually be investigated to best advantage by employing the low pass 400 cycle filter. The low pass 650 cycle filter extends the frequency limit to include most high-pitched murmurs, low-pitched rales and many types of breathing sounds. The low pass 1,100 cycle filter passes the higher frequency components of very high-pitched murmurs and high-pitched rales. For studying sounds whose frequencies are above

pressed and the murmur sounds occurring in the intervals between the beats made to appear relatively much louder than is actually the case. This filter has been so designed that while reducing greatly the intensity of the normal heart sounds, it does not entirely eliminate them, permitting murmurs to be timed with relation to their position in the cardiac cycle.

This use of the high pass 130-cycle filter is particularly valuable for making cardiograms or graphic records of chest sounds by the use of

an Einthoven or other recording galvanometer as mentioned later.

The receiver used to deliver the amplified body sounds to the ears of the observer is of the electro-magnetic diaphragm watch-case type

and is provided with a special cap and nipple instead of the usual hard rubber cap for making contact with the external ear. The nipple is designed to fit the tubing of the standard stethoscope where it is ordinarily attached to

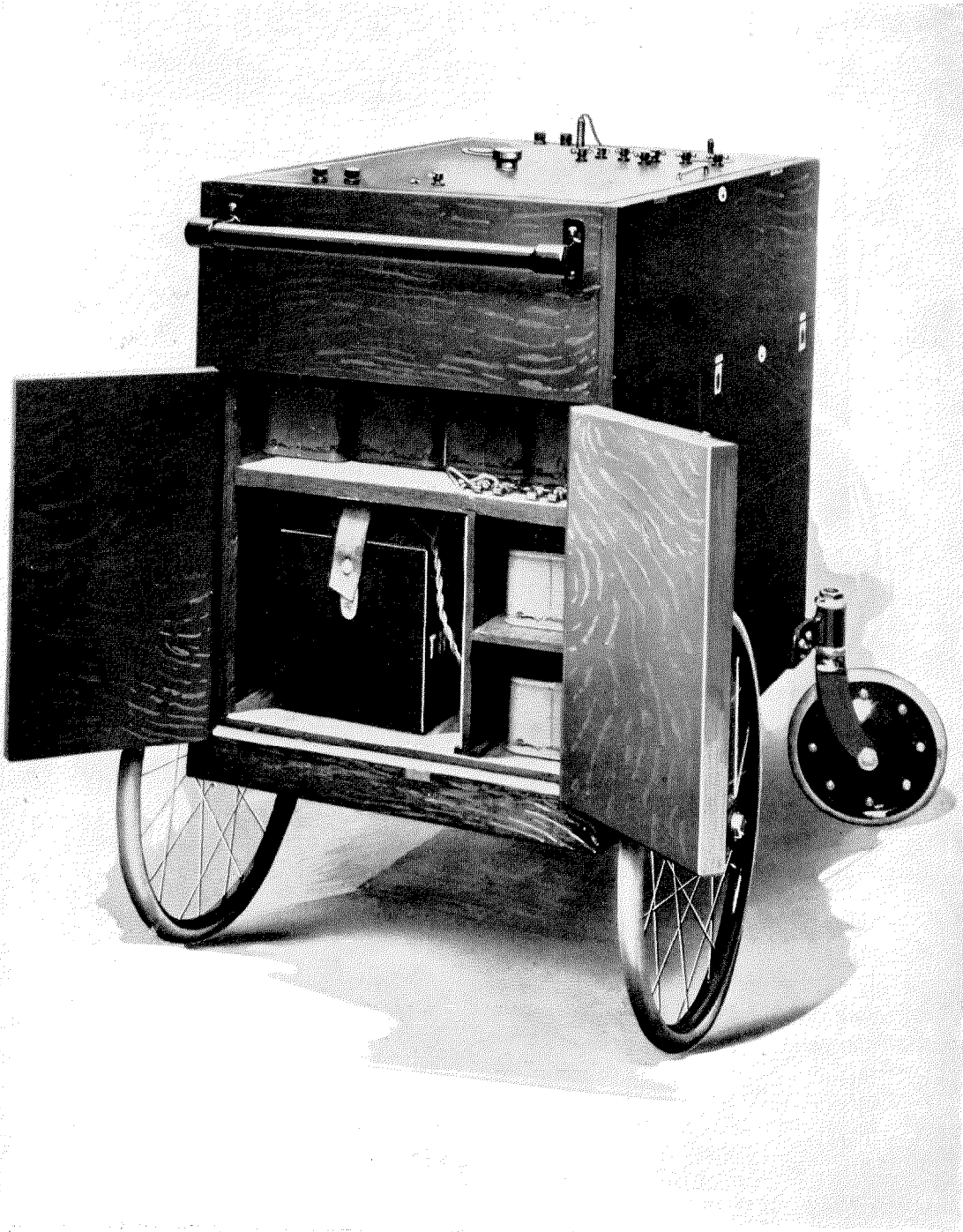

Figure 5—No. 1-A Stethophone—Showing Battery Compartment

the chest-piece. The receiver is provided with a spring clip which supports it by means of the clothing and leaves the hands of the observer free for manipulating the transmitter and control

switches of the amplifier. The stethoscope tubing of the receiver has been found to transmit sounds efficiently though with some distortion, and possesses the advantage that it permits em-



Figure 6—Stethophone in Use

ployment of exactly the same technique, which physicians are accustomed to use in auscultation. For use in bedside instruction or consultation the stethophone is equipped with ten receiver jacks by means of which any number of receiver circuits up to ten may be connected. A switch is provided for maintaining efficient

murs have been discovered with the stethophone which the ordinary stethoscope failed to detect initially, and which in some cases could not be heard with the latter instrument even after their existence was known.

The experience already obtained with the stethophone leads to the belief that it may be

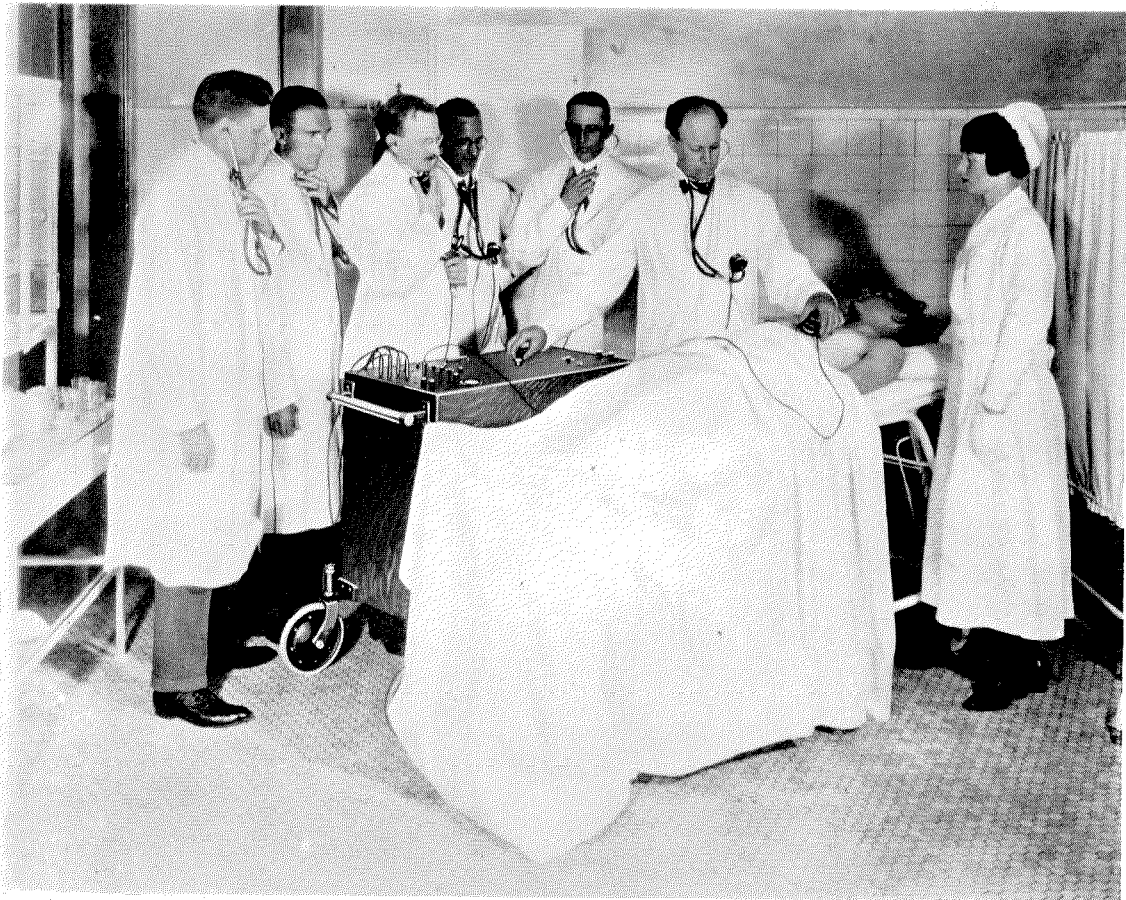

Figure 7—Clinical Use of the Stethophone

transmission whatever the number of receivers connected in the circuit.

Due to its sensitivity, power and selectivity, the usefulness of the stethophone has extended to fields beyond the realm of the acoustic stethoscope. With it, heart murmurs and rales can be observed with much greater clearness than with the ordinary stethoscope. Extremely faint sounds can be heard clearly, without great acuity of hearing by an inexperienced observer, something which has not hitherto been possible. In a number of instances mur-

used to detect symptoms of incipient pneumonia or tuberculosis at a period earlier than such symptoms can be detected by the use of the ordinary stethoscope and treatment consequently begun in time to facilitate the patient's recovery.

The stethophone is particularly well suited for instruction purposes in medical schools and hospitals. A permanent wiring system can be installed with outlets distributed among the seats of the students in any convenient manner. The instructor can announce to the class the

features of particular interest in a somewhat novel and convenient manner without requiring the students to remove the stethoscope tubes from their ears. It has been found that the flesh and bone structures of the human body respond to sound directed toward them. By first cutting out of the stethophone circuit all electric filters, which would otherwise reduce greatly the intelligibility of speech sounds, the instructor is able to communicate with the students by directing his voice towards that portion of the body to which the transmitter is applied. Where it is desired to demonstrate to a class the heart or chest sounds of patients who are very ill, as with pneumonia, and cannot be taken to the classrooms, the stethophone furnishes the only means available at the present time. For such use, the stethophone at the bedside of the patient can be connected by wiring to the lecture room. During the examination of the patient, the physician can explain to the class the different sounds heard.

Another useful application of the stethophone is the making of graphic records for the study of heart and chest sounds. For this purpose, the telephone receiver is replaced by a connection to a suitable recording galvanometer which

traces the record on a moving strip of sensitized paper or film.

By using the stethophone in connection with a special electrical phonograph recording device a number of phonograph records of heart and chest sounds have been made which, when reproduced by means of an ordinary phonograph having the horn replaced by long ear tubes, have given results differing but little from the original sounds. The long rubber tubing acts to some extent like a low pass filter for reducing "needle scratch" noises. By replacing the contact transmitter of the stethophone with a special electrical reproducing device it is possible to deliver heart and chest sounds from phonograph records to a class of students through the wiring system installed for the use of the stethophone. It appears to be easily possible to make phonograph records of all body sounds of interest and to use these regularly for the instruction of classes in medical colleges under circumstances where the study of the natural sounds is not possible.

The stethophone is, of course, only in its infancy. Extensive use in medical schools, in hospitals and by individual physicians will undoubtedly develop new possibilities and fields for using it.

A Telephone Transmission Reference System

By L. J. SIVIAN

Engineering Department, Western Electric Company, Inc.

INTRODUCTION

THE specification and maintenance of transmission standards in the telephone plant are to a large extent dependent on transmission measurements. The methods and apparatus employed in these measurements bear directly upon the transmission rating to be assigned to any given telephone circuit. There is at present no general agreement on this matter among telephone engineers throughout the world. If telephone service is satisfactorily to be extended from one system to another, it is important that the methods of measurement employed in them be equivalent, if not identical.

The so-called "Transmission Reference Systems" are fundamental to the various transmission measurements in use. These measurements essentially consist of comparisons between the unknown and the reference systems. Those reference systems now standard in several of the most important telephone administrations are unsatisfactory in a number of ways. The criticism applies with equal force from the standpoint of practical engineering needs and from that of "standards" qualifications generally recognized in physical science. Recently the matter has been given consideration by Bell System engineers with a view to developing a new reference system more nearly consistent with the present state of the art.¹ It is the purpose of this paper to discuss some of the considerations underlying this development, and briefly to report the progress made to date.

The subject is dealt with in four parts: A—The function of a transmission reference system; B—Requirements to be met by the transmission reference system; C—Work done on the construction and calibration of a preliminary model of the new transmission reference system; D—Proposed future development.

PART A—THE FUNCTION OF A TRANSMISSION REFERENCE SYSTEM

The principal function of a telephone system is to enable its subscribers satisfactorily to

carry on conversation. The adequacy with which this is done varies from circuit to circuit, and may, with time, undergo changes on any one circuit. Accordingly, the telephone engineer is confronted with the need of some method of rating the performance of telephone circuits; for comparison with one another and for the maintenance of a certain grade of transmission on any one.

There are, of course, a large number of physical factors affecting the transmission of a telephone circuit. Among those whose importance is generally recognized, several will be mentioned: (1) The reproduction characteristic of the circuit, which indicates its efficiency over the range of speech frequencies. At any one frequency it gives the ratio of the sound amplitude produced by the receiver on the ear at the receiving end to the amplitude impressed upon the transmitter at the transmitting end.² (2) The distortion due to non-linear elements. Overloading in vacuum tubes and devices employing ferromagnetic materials are examples. Most important, however, is this distortion in carbon transmitters of commercial types. (3) Noise on the circuit. (4) Phase distortion. Due to unequal velocities of propagation for different frequencies and due to reflection effects, this often is of importance on long cable circuits.

These do not complete the list and have been singled out for their importance and frequency of occurrence. Suppose for the moment that all the physical factors involved were accurately known. It would then be possible, however Herculean the task, to predict the sound output at the receiving end (expressed, say as the temporal variation of pressure at the ear drum), for any sound input at the transmitting end which the system might be called upon to handle. Would such knowledge alone in the hands of the telephone engineer enable him to rate the various grades of transmission he may encounter? The answer is in the negative, with the exception of one special case. The latter covers

¹ W. H. Martin, *Jour. A. I. E. E.*, June 1924; R. V. L., Hartley, *Electrical Communication*, Vol. 3, July 1924.

² See "The Nature of Speech and Its Interpretation" by H. Fletcher, *Jour. Franklin Institute*, Vol. 193, June 1922.

circuits which have identical sound input-output characteristics, corresponding therefore to equal grades of transmission. In all other cases no conclusion could be drawn simply because the listener's psychological reaction, as a function of the sound output in his receiver, has not been taken into account. The study of the connection between the sound output of the receiver and the listener's ability to interpret speech is a matter which is being given an ever increasing amount of attention by workers in

cable required to do this, gives the volume or loudness equivalent E of circuit C . It is assumed that the same speech source alternately actuates the transmitting ends of the reference and C circuits.

The significance attached to the equivalent so obtained, as a basis upon which to rate the transmission of circuit C , largely depends upon two factors. (1) The constancy of the reference circuit; (2) The similarity of the sound outputs in the reference and the C receivers

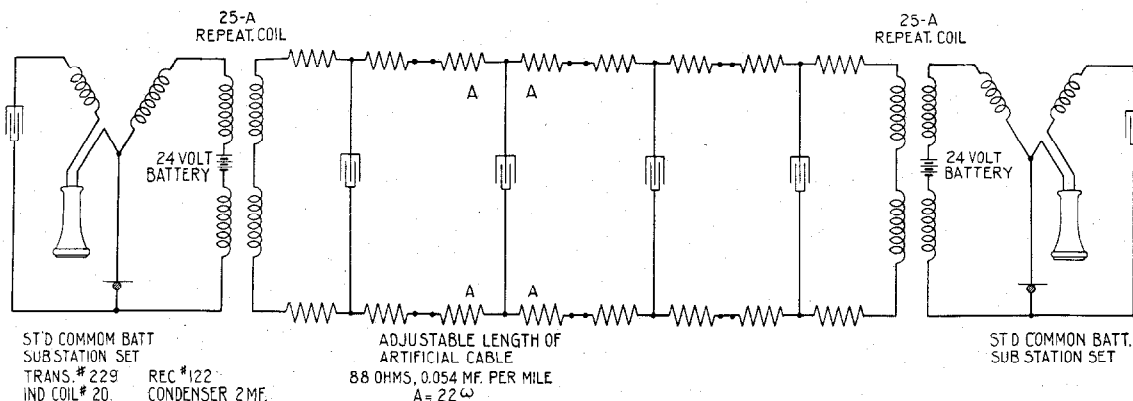

Figure 1—Bell System Reference Circuit

widely different fields.³ It is quite outside the scope of the present article to discuss this subject. We only need remember that the psychological reaction of the listener is the final criterion of the grade of transmission. Methods of rating different grades of transmission must be developed accordingly.

Before proceeding with the general aspects of our problem, let us briefly examine the one scheme of rating transmission which up to the present has found the widest engineering application. This refers to the comparison of telephone circuits on the basis of "Volume" or "Loudness" of speech in the receiver at the receiving end. The particular arrangement which has been employed for this purpose in the Bell System may serve as an illustration, and is shown schematically in Figure 1. The amount of standard cable in the reference circuit is adjusted until the loudness of speech in its listener's receiver is equal to that in the listener's receiver of the circuit C which is to be rated. The number of miles of standard

when the adjustment for equal loudness of speech has been made. This similarity refers to the psychological reaction of the listener.

Passing over the first, for the present, the second factor will be considered. It is true of a great many commercial circuits that their sound outputs differ from each other and from that of the reference circuit principally with respect to loudness. In such cases a loudness balance insures essentially identical transmission in the test and reference circuits. It can then be readily and accurately established. The equivalent E (expressed, say in miles of standard cable) of a circuit is the measurable quantity which fixes its grade of transmission. It may further be established by actual voice-ear tests that all circuits of this type give satisfactory transmission if maintained between certain two equivalents. The telephone engineer thus is in a position to measure the quantity involved in maintaining constant the transmission grades over the circuits of the system or in insuring that they are kept within prescribed limits. As is well known,

³ H. Fletcher, loc. cit.

however, there are many circuits whose sound outputs differ from that of the reference circuit in other respects than that of loudness of speech received. The latter may not even be the predominant factor. As a simple example, consider two circuits, C_1 and C_2 , having equivalent e_1 and e_2 , respectively, where $e_2 > e_1$. In accordance with the preceding definition, the loudness of speech received on C_1 is greater than on C_2 . Given a sufficient amount of line noise or cross-talk on C_1 , transmission over it, as judged by a listener, will be less satisfactory than over C_2 despite the lesser speech loudness on the latter. As the differences between circuits, other than loudness, increase in number and importance, the loudness rating alone becomes less and less adequate. Furthermore, the determination of loudness equivalents becomes correspondingly difficult and inaccurate, the individual judgment of the listener entering as an important and rather variable factor.

The situation is not without analogues in other branches of engineering. The difficulty encountered in comparing sources of light having widely different spectral distributions (say the paraffin candle and the gas filled incandescent lamp) is well recognized in illuminating engineering. There the problem is solved by the method of flicker photometry. The result obtained, however, establishes only the relative brightness of illumination from each source. It does not, directly at least, determine the merits of each source for purposes of reading printed matter, of color discernment, etc. Yet these more nearly correspond to the effects which the telephone engineer aims to incorporate into his overall rating of transmission.

Important advances have been made within the last 5-10 years toward a basis for comparing telephone circuits more comprehensive than that of loudness equivalents described above. This refers particularly to the so-called "articulation tests."⁴ The form and technique of these tests as employed by the several telephone administrations are different, but all are similar in principle. Thus, for syllable articulation, a list of syllables is made up comprising a large number of combinations of the vowels and

consonants of the language which are reasonably pronounceable. The number (averaged over a number of listeners and callers) of syllables, correctly recorded at the receiving end, divided by the total number transmitted, gives the percentage of articulation for the circuit, or briefly its "articulation." This represents a fairly objective measure of the clearness with which speech sounds are transmitted, since the observers cannot be influenced by any context or predetermined sequence of the syllables as they are called. In the great majority of cases having practical interest, the values of articulation (assuming proper care was taken in obtaining them) can be used to rate circuits in the order of satisfactoriness with which conversation can be carried on over them. It can scarcely be doubted that articulation ratings of telephone circuits will play an increasingly important part in the specification and improvement of transmission standards.

It might appear at first sight that the articulations of circuits can be used to give them absolute ratings, independent of comparison with any reference circuit. Unfortunately, such is not the case. The articulations A_1 and A_2 obtained by two different testing teams, T_1 and T_2 , on the same circuit C , will in general differ from one another by an appreciable amount. The condition of the team and the extent of its experience with a particular circuit C , are the principal causes contributing to discrepancies between results obtained by different teams. The second factor is sometimes spoken of as the "practice coefficient" of the team. If no allowance be made for these, results obtained by different teams would not, in general at least, be directly comparable. Right here is where the use of a reference circuit in the form of physically available apparatus, again is forced upon us. From the articulation obtained on the reference circuit by any team, the correction is determined which must be applied to its results for any other circuit in order to render them directly comparable with those obtained by other teams. Actually, a more dependable correction can be made if the team's articulation is known not only for the primary reference circuit, but also for an auxiliary reference circuit adjusted to a grade of transmission approximately like that of the circuit under test.

⁴H. Fletcher, loc. cit.

A further correction may possibly be required in connection with international telephony. This will be the case should future experience indicate that identical circuits lead to materially different articulations due to differences in language. The corrections to be applied to circuit ratings when passing from one language to another could be established by comparison articulation tests carried out in the languages involved. These comparison tests would be made on several reference circuits covering the range of grades of transmission which are of practical interest.

Articulation tests tell a great deal about the performance of a telephone circuit but they do not tell the whole story. It is possible to construct two telephone circuits which will give the same articulation (within errors of observation) yet differ unmistakably in naturalness of reproduction. It is not improbable that as the art progresses, criteria more searching than articulation tests will be set up for rating grades of telephone transmission. The reasons necessitating the use of reference systems in connection with articulation, will be fully as compelling in the case of more refined types of tests. For it is plain that the finer the characteristics of speech interpretation which are embraced by a system of rating, the more important it is to allow for the practice coefficient (in a generalized sense) of the testing team.

In summing up, the following conclusion appears to be justified. Any comprehensive scheme of rating grades of transmission on telephone circuits, involves in the last analysis the use of a physical reference system. Methods may be developed whereby from purely physical measurements on the circuit, the grade of transmission can be computed. But here again, voice-ear tests must supply the empirical basis for such methods, and they involve the use of physical reference systems.

There is one type of reference system which should be mentioned in a theoretical discussion of this subject. It involves no physical apparatus—the system of direct air transmission of speech from caller to observer. It is ideally simple, the only requirement being a specified distance from the caller's lips to the observer's ear. Furthermore, it is a logical and attractive idea to rate all telephone systems directly with

respect to that transmission system which constitutes the bulk of our experience—air transmission. Unfortunately, the use of such a reference system is attended by serious difficulties a few of which will be pointed out. It affords no quantitative means of controlling the output of the reference system. It requires the use of a perfectly quiet room. In general the caller must change his location when changing from the reference system to the one under test. The acoustics of the room may affect the results. Other objections might be mentioned. Those already stated are quite sufficient to rule out the practicability of what is theoretically the simplest reference system.

So far we have considered the matter from the standpoint of measuring the overall performance of the telephone circuit. The transmission engineer is continually confronted with the problem of predicting the grade of transmission corresponding to various combinations of telephone circuit elements. He must be able to do this without setting up the complete circuit for every special case under consideration. He must know the contribution to the transmission characteristics of the system due to any one of its elements when used in any given combination with other elements. For example, he must know the loudness or volume of various types of carbon transmitters in typical circuits. This is determined by placing them in a specified test circuit and comparing (by ear or otherwise) their outputs in a certain receiving circuit with that from a "standard" transmitter. This makes it necessary to have available a reference transmitter in the form of physical apparatus. Similarly a physical reference receiver is needed to rate the volume efficiency of receivers of various types. In practice the use of the reference transmitter, reference line, and reference receiver, as separate physical units is just as important as that of the reference system as a whole.

PART B—REQUIREMENTS TO BE MET BY THE TRANSMISSION REFERENCE SYSTEM

Granting that a reference system in the form of physically available apparatus is essential to accurate transmission measurements, what requirements must be met in its design? The four conditions outlined below cover the es-

sential characteristics which, it is believed, the reference system must possess.

Condition I. The performance of the system and of its component parts must be specifiable in terms of quantities admitting of definite physical measurement.

Condition II. The performance of the reference system, under specified operating and atmospheric conditions, must remain constant with time.

Condition III. The reference system must be free from non-linear distortion over the range of acoustic and electric amplitudes which it must handle.

Condition IV. The frequency response over the range of speech frequencies must be as nearly uniform as possible.

The first two conditions are obviously indispensable to the reproductibility and permanency of any standard. It only is necessary to agree upon the meaning of performance as used above. A discussion of this is given in section C of the paper, in connection with the calibration of the preliminary model of the reference system.

The third and fourth conditions require some explanation. The chief reasons for condition III are: (a) The complete specification of a non-linear system in terms of measurable physical quantities is, in general, enormously complex; (b) The same is true of any mathematical analysis pertaining to the performance of such a system. It requires a knowledge of the instantaneous values of pressure in the sound input, experimentally a very difficult thing to obtain; (c) The interpretation of comparison tests against other systems is equally involved.

Now as to condition IV. Focusing our attention upon the bulk of telephone circuits now in commercial use, it might be advanced that the reference system should be such as to make loudness comparisons with them as easy and accurate as possible. From this standpoint the reference system should have a frequency response characteristic approaching that of typical commercial circuits. However important this argument, there are others to outweigh it in favor of a distortionless primary reference system.

There already are in actual use a large number of circuits having approximately uniform frequency response. Systems handling broad-

casting and public address programs are most prominent among these, and they are rapidly growing in number and importance. The general trend of development in telephone engineering is in that direction. Our reference system will prove of greater value in the long run if designed looking forward to the progress in the art rather than backward.

Calculations relating to the use of a reference system are greatly simplified if its frequency response is uniform.

A distortionless reference system is best suited to comparisons with direct air transmission. This is an important advantage in connection with highly comprehensive systems of transmission rating which include the more elusive characteristics of sound interpretation.

The objection to a distortionless reference system stated above is primarily based on the experimental fact already referred to in Part A. It hinges on the large and variable effect of the observer's individual judgment when making loudness balances on circuits which differ substantially in other respects, *e.g.*, in frequency distortion, non-linear distortion, etc. For cases of extreme differences in circuit characteristics as many as ten observers may be required to determine the balance point with an accuracy of 2-3 Transmission Units.⁵ The solution of the difficulty readily suggests itself. It simply involves for ordinary transmission work the use of one or several auxiliary reference systems, satisfying the first three conditions for the primary reference system. The frequency response characteristic of the auxiliary systems would be made such as to render most expeditious comparisons with the commercially important types of circuits. The comparison of the auxiliary with the primary reference system insofar as that may be necessary, would be carefully carried out in standardizing laboratories only, and would, therefore, not complicate or render less certain the routine comparisons in everyday transmission measurements. In practice it might be desirable to go even further and to have auxiliary reference systems including carbon transmitters. The practical advantages of this last feature may be quite important in cases where

⁵ For a description of the Transmission Unit see W. H. Martin, *loc. cit.*, and R. V. L. Hartley, *loc. cit.*

simplicity of the reference apparatus is a paramount consideration. The transmission grade of such an auxiliary system would have to at frequent intervals be checked up against the primary or preferably against some auxiliary reference system closely approaching it in frequency distortion. This checking up of auxiliary reference systems which do not satisfy conditions I, II, and III, against those which do, must in the final analysis depend upon careful and extensive voice-ear tests. Most important among these, for the present commercial circuits, would be loudness tests.

It is readily seen that none of the four conditions outlined are met by the present reference systems. In addition to the one employed in the Bell System, there is another physical reference system in actual use. That is, the British Post Office Reference Circuit, shown in Figure 2. If it were not for the

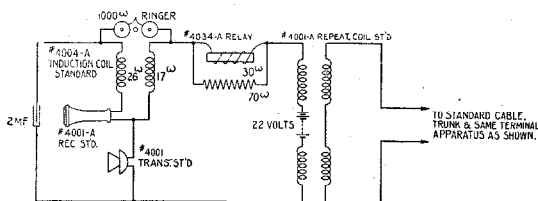

Figure 2—British Post Office Reference Circuit

carbon transmitter employed, these systems could be made to meet conditions I, II, and III fairly well, although IV would still be badly violated. The carbon transmitter combines nonlinearity with pronounced frequency distortion. Besides being nonlinear the performance of a carbon transmitter changes from time to time depending on its previous history. As a circuit element it violates every one of the above four conditions.

In this connection two further factors which may affect the characteristics of our proposed reference system, should be considered: (1)—phase distortion in the system; (2)—noise generated in the system. For our purpose the former is easily disposed of. Actual tests show that any such phase distortion as may be present in the preliminary model of the reference system already constructed, does not appreciably affect speech transmission. The same will hold true of the system in its final form.

As for noise generated in the system the obvious desideratum—zero—is not practically attainable. The reference system and its components must, of course, be designed for and operated with the minimum practicable amount of internal noise. Furthermore, the maximum permissible value of noise must be specified in terms of definitely measurable physical quantities, in accordance with condition I.

PART C—PRELIMINARY MODEL OF A TRANSMISSION REFERENCE SYSTEM

This section contains the description of a preliminary model of a transmission reference system which approximately fulfills the four conditions stated above. The apparatus was built and calibrated and some voice-ear comparisons with the present reference circuit of the Bell System were made. This was done with a view to obtaining the information needed for the design of a new reference system in its final form. Only a schematic description of the apparatus will be given, sufficient to indicate the general form which it is expected the final model will take. A detailed description and specification of the acoustical and electrical elements of the system will more properly be given after the final model is constructed. In this section whenever the expression "reference system" is used, the preliminary model built will be understood.

It consists of three parts: (1) The transmitter; (2) The line; (3) The receiver. Figure 3 shows the external appearance of all the apparatus with the exception, of course, of the filament and plate batteries required for the vacuum tubes. Figure 4 gives a schematic presentation of the several circuit elements involved.

The Transmitter

This consists of an electrostatic transmitter and associated four-stage vacuum tube amplifier. The instrument itself is essentially similar to the models described in previous publications from this laboratory.⁶ It has found extensive application in high quality transmission of speech and music, particularly in broadcasting

⁶ E. C. Wente, *Phys. Rev.*, July 1917 and *Phys. Rev.* May 1922; I. B. Crandall, *Phys. Rev.*, June 1918.

and public address work, as well as in general acoustic investigations. A thin highly stretched steel alloy diaphragm constitutes one electrode of an air condenser, a solid steel back plate parallel to the diaphragm forms the other electrode. As seen in the figure the instrument is equipped with an open wire guard which serves to keep the speaker's lips at a fixed distance from the diaphragm. This guard in itself

impedance of the amplifier is 600 ohms resistance, with negligible phase angle. In addition, the last stage contains a multi-tap output transformer, the dial and moving arm of the switch being shown in the photograph in the center of the third transmitter section. By this means the output impedance of the transmitter circuit can be made equal to 8, 16, 32 ————— 16,384 ohms. It is thus possible to operate the

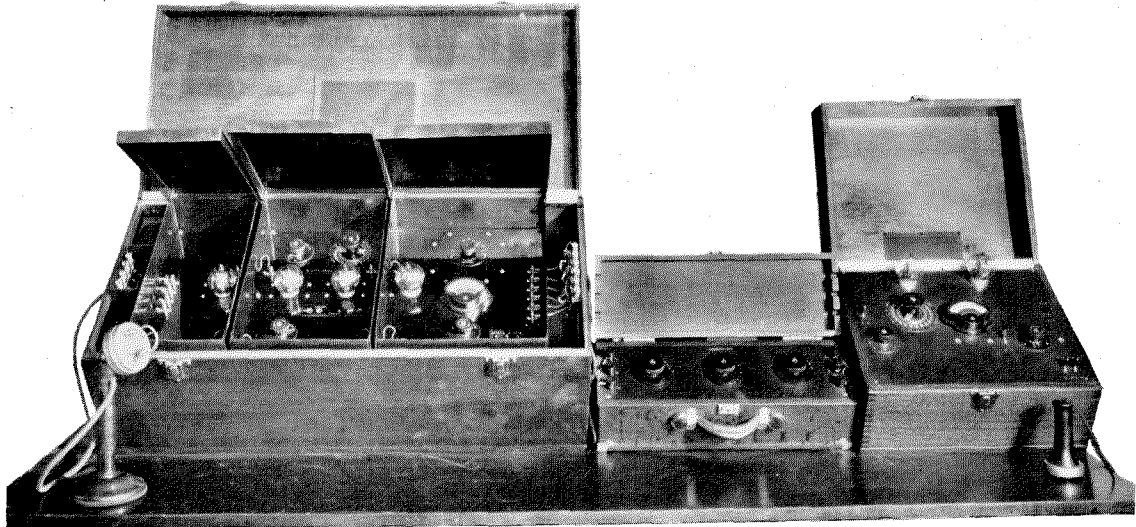

Transmitter Line Receiver
Figure 3—Preliminary Model of Telephone Transmission Reference System

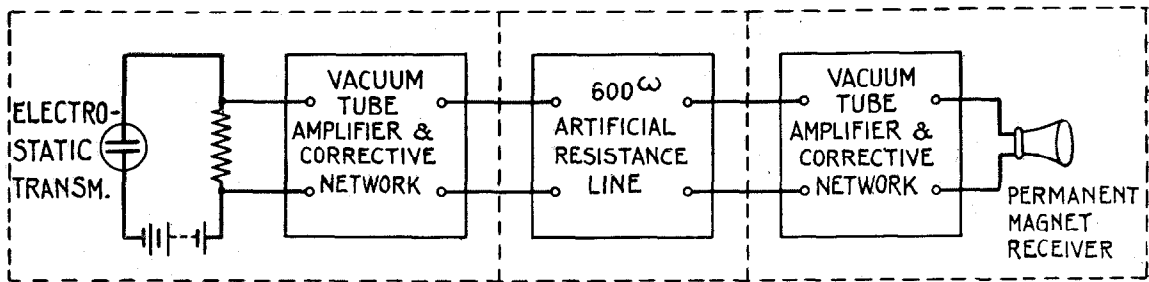

Reference Transmitter Reference Line Reference Receiver
Figure 4—Schematic of Preliminary Model of Transmission Reference System

does not appreciably alter the acoustic performance of the transmitter. The capacity of this air condenser is varied by the motion of the diaphragm due to sound vibrations impinging on it. A polarizing battery and a high resistance are in series with the transmitter. The alternating potential generated across this resistance is approximately a faithful reproduction of the sound wave actuating the diaphragm. This is amplified by the four-stage amplifier. The stages are resistance coupled. The output

transmitter without appreciable reflection effects into any resistance load between 6 and 22,000 ohms. This is a valuable feature when using the transmitter in combination with loads other than the reference line, but is not regarded as an essential feature of the reference system.

A potentiometer between the second and third stages provides for control of the transmitter output over a range of 20 TU (a power variation of 100:1) by steps of 1 TU i.e., a power variation of 10^{0.01}:1. The potentiometer switch is shown

in the right half of the second transmitter section. An additional potentiometer giving a continuous variation of approximately $\pm 1 TU$ is provided for making fine adjustments to allow for small variations in tubes, batteries, etc., in bringing the transmitter to its standard adjustment. This is shown to the left of the first potentiometer.

The keys, jacks and meters seen on the amplifier panels are provided for measuring the plate and filament battery potentials, and the plate and filament currents in the tubes. A rheostat for regulation of filament current is shown at the bottom of the third section.

The electrostatic transmitter circuit contains a small resistance for the purpose of introducing known calibrating voltages. It is brought out to the lower pair of terminals, shown at the extreme left of the photograph.

All the apparatus is mounted on the underside of the micarta panels seen in the photograph. Any part of it is accessible upon lifting the corresponding panel out of its shielding box. These boxes are made of iron completely enclosing the apparatus excepting, of course, the transmitter and are connected to ground. A shielded flexible connection, about 30 inches long, is used between the transmitter and its amplifier.

The Line

This is a distortionless resistance line having a total range of 61 Transmission Units. Three dials are provided as follows: the first dial gives five 10TU steps, the second ten 1 TU steps, and the third five 0.2 TU steps. The size of the steps on the last dial was chosen sufficiently small to meet the needs of any auditory tests for which the system might be used. The line is made up of balanced networks, non-inductively wound, and has an impedance of 600 ohms. All elements of the line are enclosed in a metallic shield which is connected to ground.

The Receiver

This consists of a special receiver of the permanent magnet type preceded by a two stage amplifier. The instrument has a magnetic structure quite similar to that of the commercial desk stand type. It differs from

the latter in two important respects. (1) The diaphragm is clamped between metal surfaces having temperature coefficients of expansion equal to that of the diaphragm. This renders the performance of the instrument practically independent of any ordinary temperature variations. (2) The diaphragm is much more highly damped. A number of thin paper rings are placed on the underside of the diaphragm. The air layers contained between the paper rings and the air layer between the diaphragm and the topmost paper ring are largely responsible for the high degree of damping which this instrument possesses. The purpose of this damping, of course, is to reduce the effects of the diaphragm resonances.

The two amplifier stages are coupled by means of a choke-coil whose impedance is sufficiently high over the entire speech frequency range. The input impedance is approximately 600 ohms matching that of the artificial line. The amplification can be varied by steps of 1 TU over a range of 20 TU. The dial and moving arm may be seen just below the first tube in the photograph. An additional potentiometer, to the left of the first one, permits a continuous variation corresponding approximately to $\pm 1 TU$. This is for standard adjustment and takes care of any small variations in tubes, batteries, etc. The keys, jacks and meter seen on the panel provided for measuring the plate and filament battery potentials, and the plate and filament currents, a rheostat for regulating the filament current, is shown on the right in the photograph. The input circuit contains a small resistance across which known voltages may be impressed for calibrating purposes. All the apparatus, excepting the receiver proper, is contained in a metal shielded box, the shield being connected to ground.

A more detailed description of the apparatus is not deemed worth while at this stage of the work and is reserved for the report on the reference system in its final form. We may assume that the latter will in most of its essential features resemble the preliminary model. It is important, therefore, to examine the system described from the standpoint of the four conditions which we concluded must be satisfied by a transmission reference system.

This will be done in the order in which those conditions were named above.

Condition I—The performance of the system must be specifiable in terms of quantities admitting of definite physical measurement. This is done for our system by specifying for any frequency throughout the important speech range (*i.e.* from 100 to 5000 cycles), the sound output of the receiver corresponding to a given sound input to the transmitter.

The sound input to the electrostatic transmitter is given as the alternating pressure (in r.m.s. dynes per sq. cm.) acting on its diaphragm. A definite sinusoidal pressure on the diaphragm is produced by means of a thermophone receiver as indicated in Figure 5. For the theory, construction and use of the thermophone the reader is referred to previous publications from this laboratory.⁷ It is suf-

air-tight. The transmitter, without the brass coupler, was previously calibrated by means of a thermophone receiver. The electrical output of the transmitter gives a measure (in effective r.m.s. dynes per sq. cm.) of the sinusoidal pressure on its diaphragm, and hence of the sound output of the receiver. The dimensions and material of the coupler affect the measurements, and must of course be specified. The sound output of the receiver can thus be measured up to frequencies of about 5000 cycles with an average reproducibility of $\pm 2\%$.

The specification of the line is purely an electrical matter, dealt with by well-known electrical methods which need not be discussed here. It is plain that this part of the system is readily made to conform to conditions I, II, and III. As for condition IV, rather careful

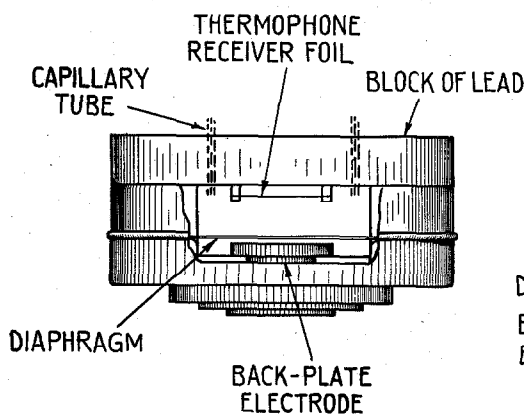

Arrangement for Calibrating Electrostatic Transmitter

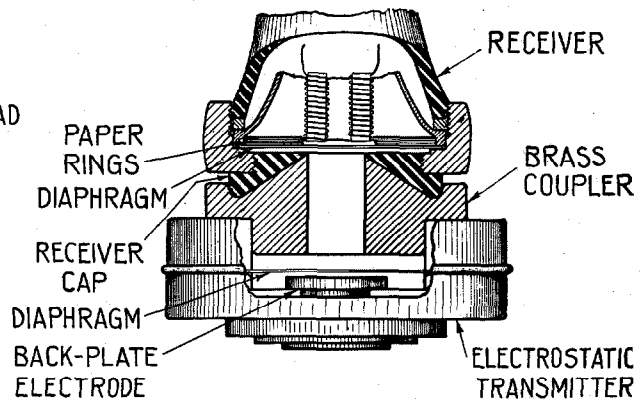

Arrangement for Calibrating Permanent Magnet Receiver

Figure 5

ficient to state here that for all frequencies up to about 5000 cycles approximately uniform sinusoidal pressure of known value can be generated at the diaphragm of the electrostatic transmitter with an average reproducibility of $\pm 2\%$.

The sound output of the receiver is measured as indicated in Figure 5. The sound from the receiver is impressed on the diaphragm of a calibrated electrostatic transmitter through a brass coupler. The fit between the latter and the receiver and the transmitter is nearly

⁷H. D. Arnold and I. B. Crandall, *Phys. Rev.*, July 1917; E. C. Wentz, *Phys. Rev.*, April 1922.

design is required in order that stray capacities, etc., do not appreciably affect the theoretical attenuation at the high frequencies and high values of attenuation. This was done for the reference artificial line with an accuracy in excess of that warranted by the characteristics of other components of the system.

It is outside the scope of this paper to go into the physical theory underlying the sound input and output measurements described above. The reader is referred to the publications on the thermophone receiver, and the electrostatic transmitter, and to standard treatises on acousti-

cal theory. A few words of explanation, however, will serve to obviate misunderstanding which might otherwise arise. First, as to the transmitter calibration. It depends on the theory of the thermophone which permits the calculation of the pressures impressed on the transmitter diaphragm. This is the most accurate method, theoretically and experimentally, so far developed for producing known, and approximately uniform sinusoidal pressures at the transmitter diaphragm over the entire range of speech frequencies. That is the reason for its use in this connection. If the result could be equally well accomplished by any other method its use for the purpose would be justified. A number of methods have been proposed and investigated at various times, notably by M. Wien, Lord Rayleigh, and by A. C. Webster. Unfortunately all these proposals are attended by serious theoretical and experimental limitations, especially if the wide range of speech frequencies to be covered is taken into account. For the present therefore, the thermophone procedure is regarded as the last court of appeal in the matter of producing known (in absolute physical terms) sound inputs to the electrostatic transmitter over the range of speech frequencies.

Much the same argument applies to our "sound output" determination since it depends on an electrostatic transmitter which is calibrated by means of the thermophone procedure. The output measurements were made with a coupler. The particular coupler was chosen for the reason that when used with the reference receiver instrument the pressures produced on the electrostatic transmitter diaphragm are roughly the same as those on the ear-drum when the receiver is held on the ear, over the range from 500 to 4,000 cycles. The output measurement thus possesses the advantage of giving a rough approximation to the receiver output when held on the ear. A disadvantage is that only effective pressures over the transmitter diaphragm are measured, the pressure being far from uniform over all parts of it at the higher frequencies. This probably is not an important consideration for the present purpose. It may, however, turn out desirable as the work progresses to arrange the output measurement so as to produce more nearly uniform pressures over the transmitter diaphragm.

Condition II. The performance of the reference system under specified operating and atmospheric conditions, must remain constant with time. Our knowledge of the extent to which this is fulfilled is limited by the accuracy with which sound input and sound output can be measured. The question naturally resolves itself into three parts.

1. Constancy of the electrostatic transmitter. As stated above this can be checked to within approximately $\pm 2\%$. Experience in this laboratory has shown that a properly built transmitter, handled with care and protected from excessive variations in atmospheric conditions has remained practically constant over a period of several years.
2. Constancy of the electrical circuit. This may be defined as the constancy of the voltage produced across a fixed resistance in place of the receiver instrument per 1 volt impressed across the calibrating resistance in the electrostatic transmitter circuit. This involves a purely electrical measurement and can be made with an average accuracy of $\pm 1/2$ to 1% over the frequency range. The aging of the tubes and battery fluctuations are the only important sources of variation. By proper selection of tubes and maintenance of batteries, this variation can be kept down to a minimum, the residue being easily taken care of by means of the standard adjustment potentiometers mentioned above.
3. Constancy of the permanent magnet receiver. Here again everything depends upon the reproducibility with which the sound output can be measured which is about $\pm 2\%$. Extensive tests have been made to determine the effects of temperature and humidity. The receiver diaphragm is paper damped and iron clamped. Temperature variations from 0°C. to 40°C. and humidity variations from 40% to 80% do not, within the limits of measurements, affect the performance of the instrument when brought back to normal conditions, say 15°C. - 25°C. and 50% - 60% humidity. No variations have been

observed due to aging of the permanent magnet. The latter is used because it is more convenient and because of the vastly greater experience available for its design as compared with the electro-magnetic type of instrument. This experience extends to nearly all direct current meters as well as to telephone instruments. The electrostatic receiver, despite its excellent frequency characteristic, is not used because of the difficulty of maintenance and operation and because sufficiently large sound outputs cannot be obtained with it without overloading.

To sum up the reference system described if maintained under proper operating and atmospheric conditions, can be depended upon to stay constant within the limits of accuracy of the acoustic measuring technique that is about $\pm 2\%$ averaged over the frequency range.

Condition III.—The system must be free from non-linear distortion over the range of acoustic and electric amplitudes which it must handle. The pressure amplitude of the receiver output must be proportional to the amplitude of the input to the transmitter. In contrast with conditions I and II, the electric circuit now is the weakest link in the chain.

1. The voltage output of the electrostatic transmitter, as used here, *i.e.* with a polarizing voltage of 250 volts, is sensibly proportional to the input pressure up to the largest pressures occurring in speech.
2. Non-linearity in the electric circuit may occur due to over-loading in the vacuum tubes, particularly in the transmitter circuit. This is hardly apt to occur in the receiver circuit because of the large attenuation (about 24 *TU*, as will be seen later) normally used in the line between the transmitter and receiver. Measurements were made to determine how nearly linear the response of the transmitter circuit is. It was found that up to input voltages corresponding to the highest pressures in speech, the voltage output is proportional to the input, within the accuracy limits of the experiment. This is for the normal amplification setting of the transmitter circuit to be more fully defined below. The

receiver circuit input-output characteristic is equally linear over the range of inputs which it must handle.

3. The permanent magnet receiver. The sound outputs of the receiver, over the range of pressures which it must handle, have been investigated by analyzing the electrical output of the electrostatic transmitter to which the receiver is coupled by means of the brass coupler. Over the range of pressures which the receiver must be capable of producing, no extraneous frequencies, as large as 1% of the impressed frequency could be detected in the sound output of the receiver. This is sufficient to establish a close approach to linearity.

Condition IV.—The frequency response over the range of speech frequencies must be as nearly uniform as possible. The situation here is rather different than with the preceding three conditions. It takes us beyond measurements on physical apparatus alone, if the term "frequency response" be made to include the speaker's mouth as the sound source at the transmitting end and the listener's eardrum as the sound collector at the receiving end. This, broadly speaking, is necessary in order to bring the frequency response into immediate correlation with the capacity of the system for transmitting speech characteristics. The frequency calibration of the reference system in its final form will be based on this definition of frequency response. The theoretical basis and the experimental realization of such a calibration would lead us too far afield. For the present purpose, which is merely illustrative, a less comprehensive definition will be used. The frequency response will be taken as the effective pressure produced on the electrostatic transmitter diaphragm coupled to the listening receiver by means of the brass coupler, per unit pressure (approximately uniform over its surface) applied at the diaphragm of the electrostatic transmitter at the transmitting end. As stated before the particular coupler used was such that between 500 and 4000 cycles the frequency response determined with it is roughly the same as if the pressures at a listener's eardrum were measured.

The performance of the artificial line is constant for all frequencies in question. Since the

transmitter output impedance and receiver input impedance are practically pure resistances, the frequency response of the transmitter and receiver can be treated separately. For the transmitter (instrument+amplifier) it was found that between 100 and 5,000 cycles the value of the output voltage—input pressure ratio was within $\pm 15\%$ from the mean. For the receiver (instrument+amplifier) as it now stands, the output pressure—input voltage ratio shows much larger variations with frequency. The maximum value is about 10 times greater than the minimum in the range from 100 to 5,000 cycles. This is almost entirely due to the instrument characteristics. By means of suitable corrective circuits the variation can be reduced so as not to exceed about $\pm 30\%$ deviation from the mean. At present, further work is required to make the receiver frequency response as uniform as that of the other components of the system.

The frequency response is very nearly the same for all amplification settings of the transmitter and receiver circuits. It is not appreciably different for the several taps on the output transformer of the transmitter circuit. The impedance variations with frequency of the transmitter and receiver circuits also are so small as not to affect the transmission by more than 2 to 3% at most.

Standard Settings and Voice-Ear Tests

So far we have not explicitly specified the absolute values of the ratio of sound output to sound input in our reference system. Given the reference transmitter and receiver instruments, the question is essentially one of choosing the standard values of amplification in the transmitter and receiver circuits and of the attenuation in the intervening line. The considerations underlying the choice made were largely based on loudness comparisons with the reference system shown in Figure 1. It is obviously desirable that the process of changing over from that reference system to the one here considered, be attended with a minimum amount of readjustment in the transmission data now used in the laying out and maintenance of the commercial telephone plant. So far as the old reference system is concerned, these data refer only to loudness. The loudness of the old system

with 24 miles of standard cable in the line is taken as a typical compromise between local and long distance transmission standards. It is most convenient then to adjust the new system to be equal in loudness to the old when there are 24 *TU* in the new reference line, and 24 miles in the old reference cable, respectively. This is not sufficient to determine individually the amplifications in the transmitter and receiver circuits of the new system. These are arrived at by adjusting the amplification of the reference receiver circuit so that its receiving efficiency (on a loudness basis) is equal to that of the receiving subset in the old system. The amplification of the reference transmitter circuit is then uniquely determined. In this way the standard settings of the new reference system are selected. The measurements involve making voice-ear loudness balances between the old and new system, in other words, for speech of two widely different qualities. This was done in a purely preliminary manner, not with the object of definite determination of the standard settings of the reference systems but rather to obtain the approximate data required in connection with the final design of a new reference system. This is particularly necessary in order to insure that there will be no appreciable overloading in any part of the reference system under all conditions of test which it must be able to handle.

PART D—PROPOSED FUTURE DEVELOPMENT

Sufficient information has been obtained in connection with the preliminary model described above to proceed with the design of the apparatus which will constitute the new reference system. This work is now in progress. The new system is not expected to differ essentially from the model described. It is to satisfy the four conditions stated above. In particular an effort will be made to improve the frequency response of the receiver part of the system over that in the preliminary model. The type of apparatus employed is to be essentially the same as described. The standard settings of the three components of the system will be determined by extensive voice-ear tests against the reference system now in use, based on some such condition as stated above. All parts of the system are to be cali-

brated in Transmission Units. The system will be built in three parts; the reference transmitter, the reference line and the reference receiver, which can be used together or separately in combination with any other elements of a telephone system.

This is to be a primary standard maintained under specified atmospheric conditions and subject to a minimum amount of handling. Secondary standards will be built for use in the more important telephone centers. These will be adjusted to identity with the primary standard.

In addition it is proposed to build auxiliary standards more suitable for practical transmission measurements in connection with commercial circuits. They will, however, be made to satisfy the first three conditions for a reference system as closely as practicable. This will probably require the use of relatively simple amplifier circuits. They will be carefully calibrated, physically and by voice-ear tests, against the primary or secondary systems.

Finally, reference circuits containing carbon transmitters such as shown in Figures 1 and 2 probably will continue in practical use for some time to come. Their maintenance and adjustment will be made far more reliable by calibration against the auxiliary or the secondary standards than has been possible hitherto using the so-called carbon transmitter "standards."

It will be seen, therefore, that the proposed development of the transmission reference systems, primary, secondary and auxiliary will in no way increase the difficulties or add to the complexity of transmission measurements. It will merely place them on a scientific basis more nearly consistent with the progress in the art than has been the case in the past. The rather cumbersome primary and secondary systems will remain in the background as final courts of appeal to be held in the world's "telephone standardizing laboratories." The bulk of actual transmission measurements will be made with the relatively simple auxiliary systems.

Carrier Telephone Equipment for High Voltage Power Transmission Lines

By N. H. SLAUGHTER

Engineering Department, Western Electric Company, Inc.

THE problem of directing and controlling the operation of a large power transmission network is one of the most vital importance and increases rapidly with the size of the network and with the voltage and power transmitted. Generating stations, often of large size and widely separated from each other, substations where the power

is transformed or where interconnections are made with other networks, demand for their efficient operation and coordination an efficient and reliable communication system to keep them in touch with each other and with the central load dispatcher. Still more in times of emergency the possibilities of damage to the expensive power equipment and of danger

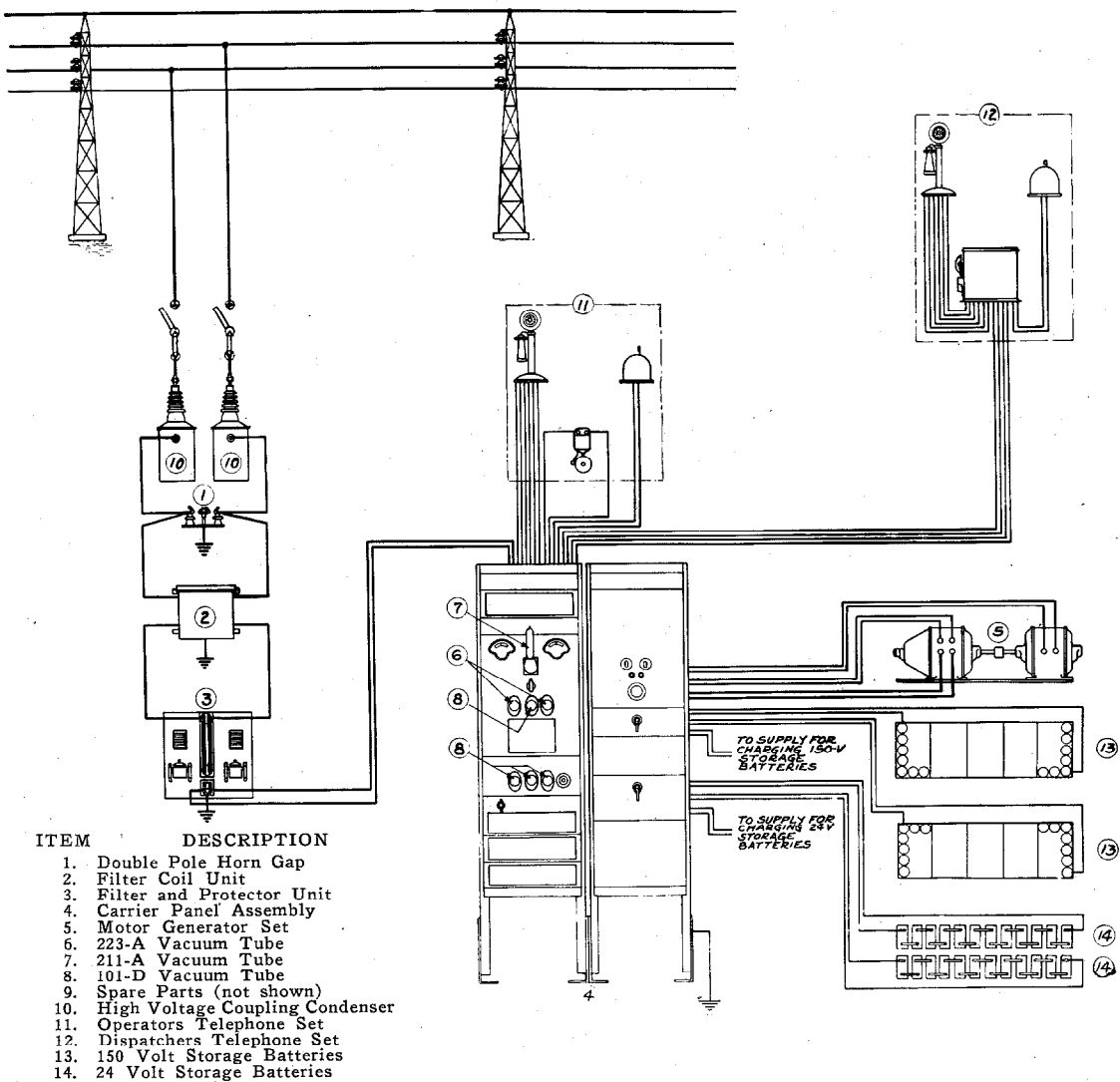

Figure 1—Schematic Wiring of Carrier Terminal Employing Condensers

to employees and to the public make it imperative to provide the best possible means of communication.

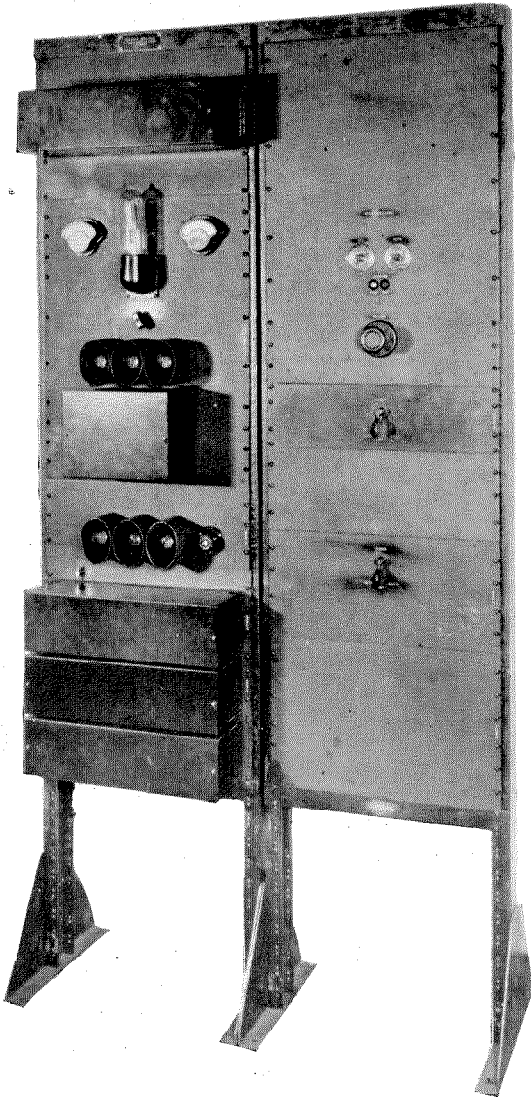

Figure 2—Carrier Panel Assembly

Physical telephone lines have long been employed by power transmission companies with a degree of success that depends largely on the particular conditions applying in a given case. Two general types of such circuits have been used; the telephone line supported by the transmission line towers, and the telephone line carried on separate poles. Both of these are open to serious objections, the most important of which are the possibility of failure under adverse weather conditions,

and their susceptibility to interference in times of electrical troubles on the power lines. Other difficulties, such as comparatively poor transmission due to excessive power induction noises, hazard to the user due to induced voltages set up in the telephone line, large initial investment and large maintenance expense necessary to keep such telephone lines in satisfactory operating condition, all tend

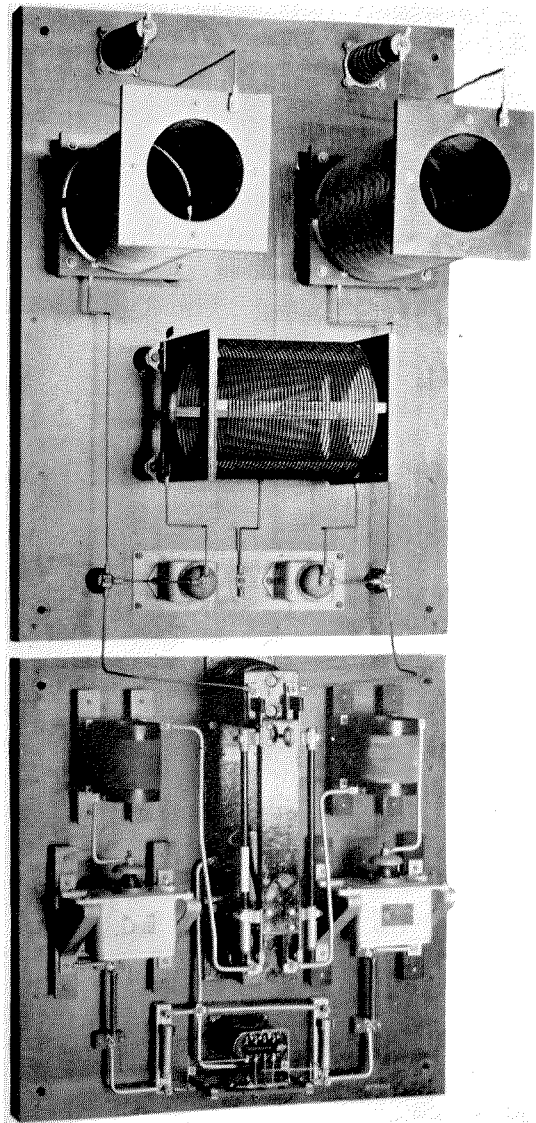

Figure 3—Coupling and Protection Panels

to discourage the use of physical telephone lines for providing the necessary telephone facilities.

During the last few years a new method of providing telephone communication over power transmission lines has been developed. In this method the power transmission conductors themselves form the transmission medium for the telephone currents, and thereby the advantages of the very substantial power line construction are afforded the telephone circuit. In order to use the power conductors as a medium for the telephone transmission, it is necessary to make use of the so-called "carrier current" method whereby a comparatively high frequency "carrier current" is employed for the telephone transmission. These carrier currents are separated from the power currents

quality of transmission and its freedom from noise are superior to the service that will ordinarily be afforded by physical telephone lines maintained by the Power Companies and carried either on the same transmission towers or on separate poles. The expense of providing service by the carrier method will usually be considerably less than that of service from physical telephone lines since no line maintenance is involved and since the investment in carrier equipment will be less than that of any but very short telephone lines.

The carrier method is adapted to giving a number of separate telephone channels over the same power transmission lines by means

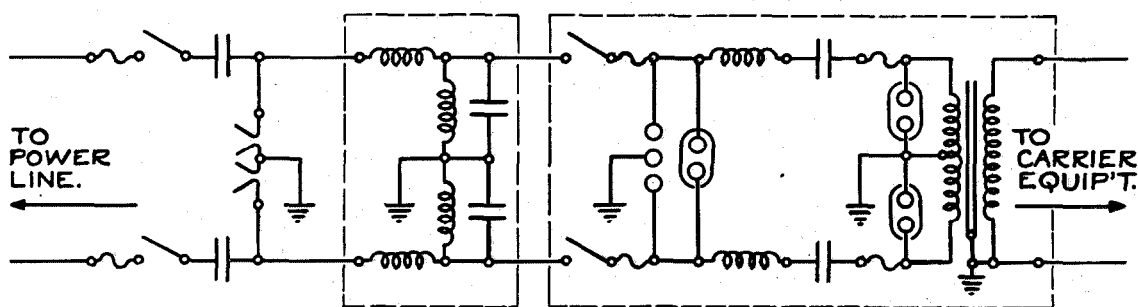

Figure 4—Schematic Wiring of Coupling and Protection

at the terminals by means of selective circuits or electric filters,¹ and this separation is so complete that no trouble whatever is experienced in establishing a telephone circuit which is entirely free of the power hum characteristic of most physical telephone lines provided by the power transmission companies.

It is at once evident that a telephone circuit provided in the above manner is quite superior to ordinary methods, since the power conductors themselves furnish the transmission medium, and thereby a degree of reliability in transmission is obtained which is equal to that of the power transmission line itself. Under any condition which permits power to be transmitted over the transmission line it will be possible to use the line for the telephone transmission also; and in some cases when the line is actually opened or grounded, telephone communication will still be possible. The

¹ Electric filters are widely used in telephone transmission where currents of different frequencies are to be separated.

of the multiplex feature which has been already applied so successfully to carrier current communication over telephone lines. This feature is apt to be of very considerable value as power transmission lines become more largely interconnected. For example, the load dispatcher's office of one system may wish to be in communication at any given time with one of his own station operators and at the same time with the load dispatcher of some other interconnected power system.

In developing carrier telephone equipment for use on power transmission lines, the Western Electric Company has made an extensive study of the transmission losses which are encountered when carrier currents are transmitted over power lines. These losses are due partly to the loss in the transmission conductors themselves and partly to the shunting loss due to connected power apparatus. Based on the data which have been obtained from these tests, the arrangement which has been adopted is a full metallic circuit using two of

the power line conductors as the two sides of the telephone circuit. This arrangement is so decidedly superior from every standpoint to the more commonly employed arrangement

of a ground return circuit that it will undoubtedly become the standard arrangement for all carrier systems.

The most difficult problem which has been

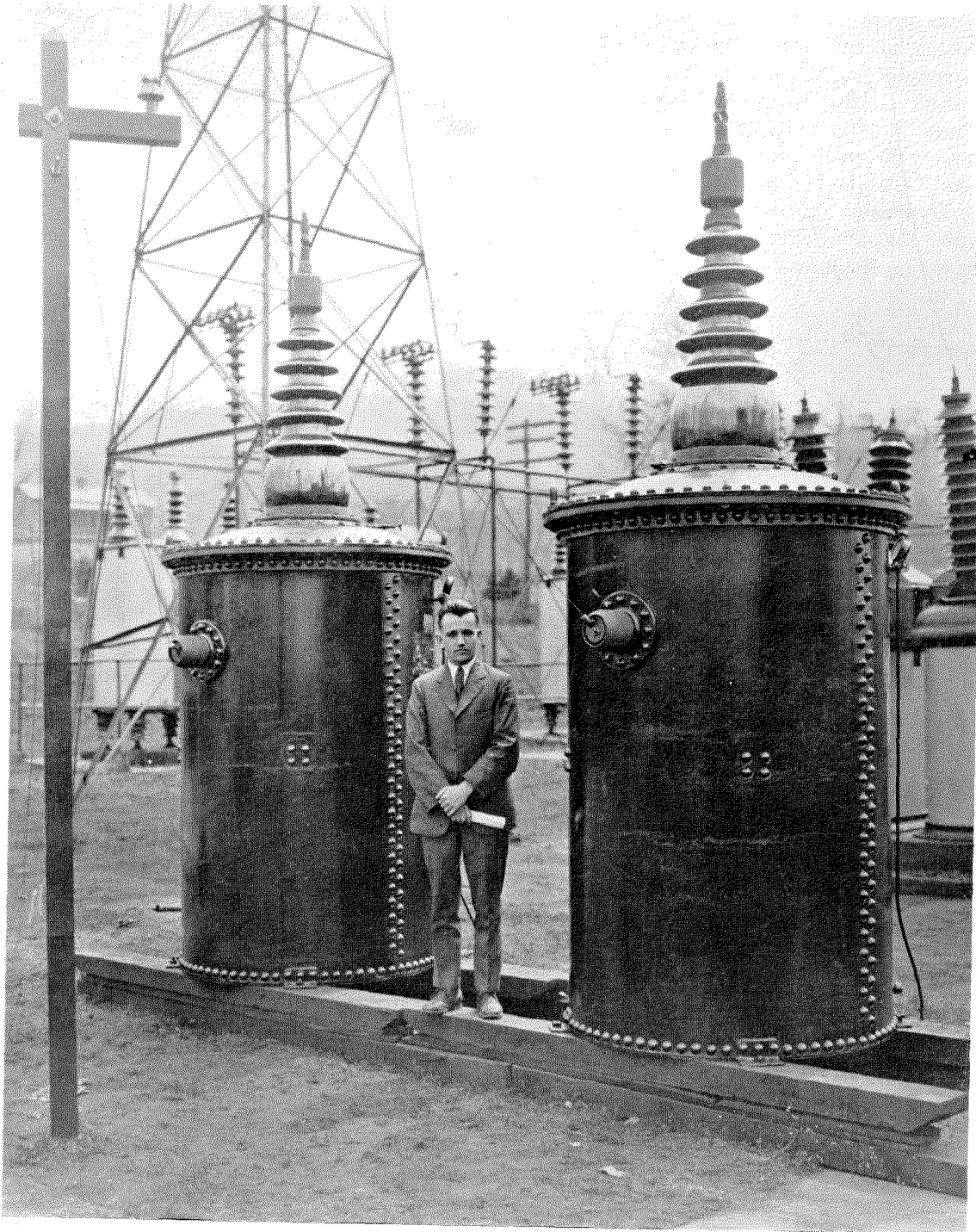

Figure 5—High Voltage Coupling Condensers—120 K.V.

encountered in the application of carrier current telephony to power transmission lines is that of efficiently connecting the carrier current equipment to the power line conductors. Two methods have been chosen, in each of which the connecting medium is a capacity. In one of these arrangements this capacity is obtained by stringing parallel to the power

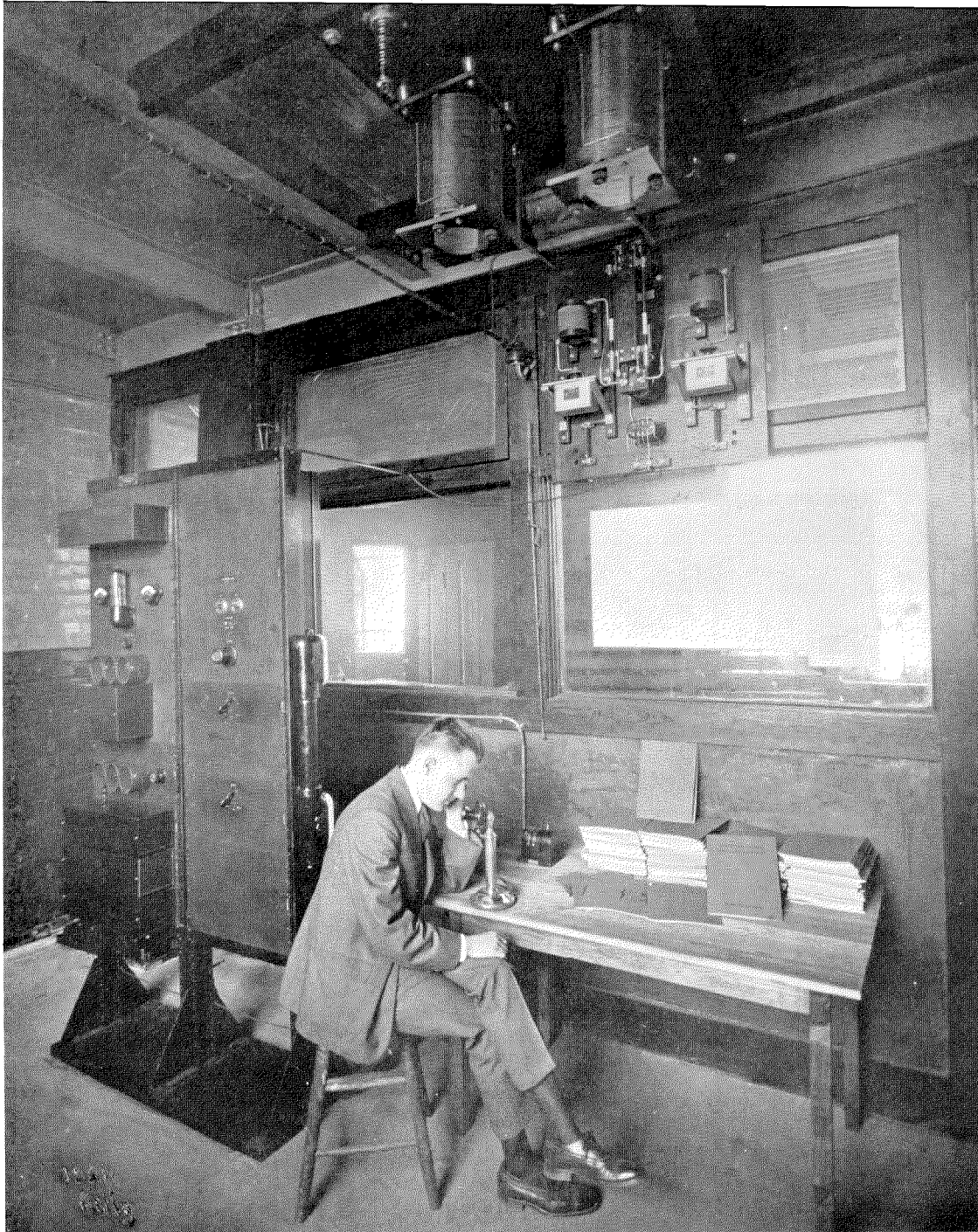

Figure 6—Complete Terminal Equipment

line conductors two so-called antennas extending for perhaps 1500 feet along the transmission line. The carrier equipment is connected to the two antennas and the carrier currents are transferred to the power line conductors through the medium of the capacity between the antenna wires and the adjacent power line conductors. In the other arrangement high voltage coupling condensers are

designed primarily from the standpoint of simplicity and reliability as regards both its installation and operation. The development of this equipment has been founded on many years of experience in the older arts of long distance telephony and the application of carrier current systems to telephone lines. The problems and technique involved in power line carrier are not fundamentally different

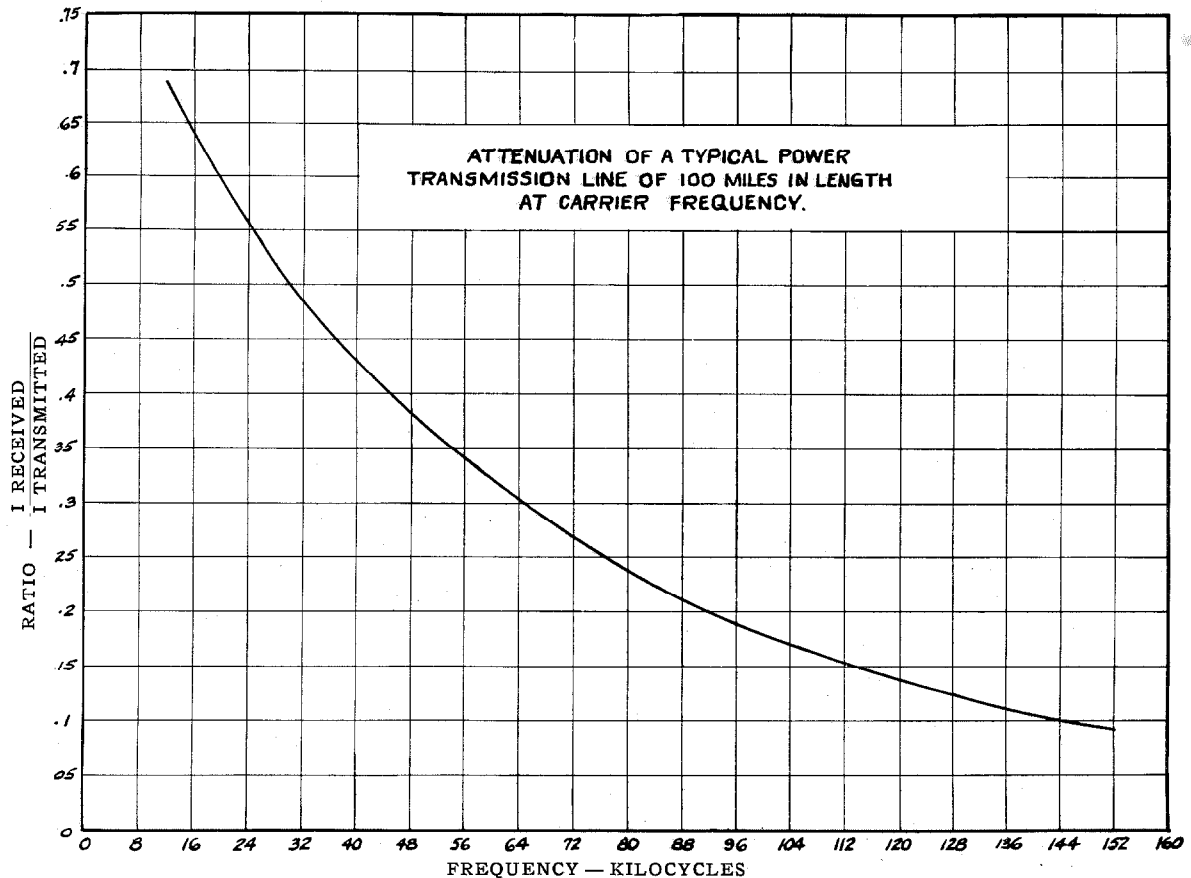

Figure 7—Power Line Attenuation Curve

used as the connecting medium. In either case the two fundamental requirements are that the coupling must be efficient and safe. A complete system of protection has been provided which assures freedom from danger in case of accidental contact between the power line and the antennas, or in case of breakdown of the coupling condenser, and at the same time introduces substantially no loss to the carrier currents.

Carrier equipment which has been developed by the Western Electric Company has been

from those of telephone line carrier, in fact many of the requirements are much less exacting. As a result the power line carrier equipment developed by the Western Electric Company makes use of many elements which have already proved their merit over a period of years in commercial telephone practice.

The service that is afforded is entirely automatic from the standpoint of the user, and the quality of the transmission is equal to that which is afforded by high grade commercial circuits. Ringing is selective, being obtained

through the use of equipment now standardized in Western Electric train dispatching telephone throughout the world. The telephone circuits which are afforded by this carrier system can be extended through the private switchboards of the Power Company and handled as ordinary telephone circuits. All power for the equipment is obtained from storage batteries, rendering its operation independent of any commercial supply. This is made possible by reason of the unusual efficiency of the apparatus whereby satisfactory transmission is accomplished with much lower power than has heretofore been considered necessary.

One of the most important elements in any carrier current equipment is the vacuum tube. The tubes which are employed for this equipment are the result of long years of development work on vacuum tubes for telephone repeater stations. As a result there has been made available for this equipment vacuum tubes having thoroughly satisfactory characteristics. As an example, the life of the tubes is such that replacements should not be necessary more than once a year for either the transmitting or receiving tubes.

Open sectionalizing switches introduce a substantial obstacle to carrier transmission over power lines. Another difficulty is offered

when there is a change in the voltage of the transmission line. At such a point the transformer or auto-transformer employed to effect the change acts as a substantial barrier to the carrier frequency currents. Fortunately, however, by means of a comparatively simple arrangement known as a "by-pass antenna," the currents can be effectively transferred around such a barrier, although the loss incurred is considerable even with the by-pass.

For the purpose of obtaining satisfactory operation under adverse conditions, the Western Electric equipment has been designed to include an emergency power amplifier. Normally the power which will be required for satisfactory transmission on most installations is of the order of one watt. The emergency amplifier increases this power to about 50 watts and the difference between these two power outputs is sufficient to compensate for the cases of adverse transmission.

Throughout this work the controlling consideration has been to develop equipment which would give the utmost reliability and simplicity in operation. Furthermore, due to the high transmission efficiency of the complete system, the attainment of the desired result with the use of very low power has left open the way to expansion to meet the growing needs of the future.

Supervisory Systems for Remote Control

By J. C. FIELD

Engineering Department, Western Electric Company, Inc.

IN many branches of industrial life, there is a growing tendency towards centralization of responsibility. This has been found to insure coordinated operation of the system as a whole, to eliminate duplication

different operating conditions. In many cases, the substations are automatic and consequently are entirely unattended. In such systems it is doubly important that someone should be kept informed at all times of the exact

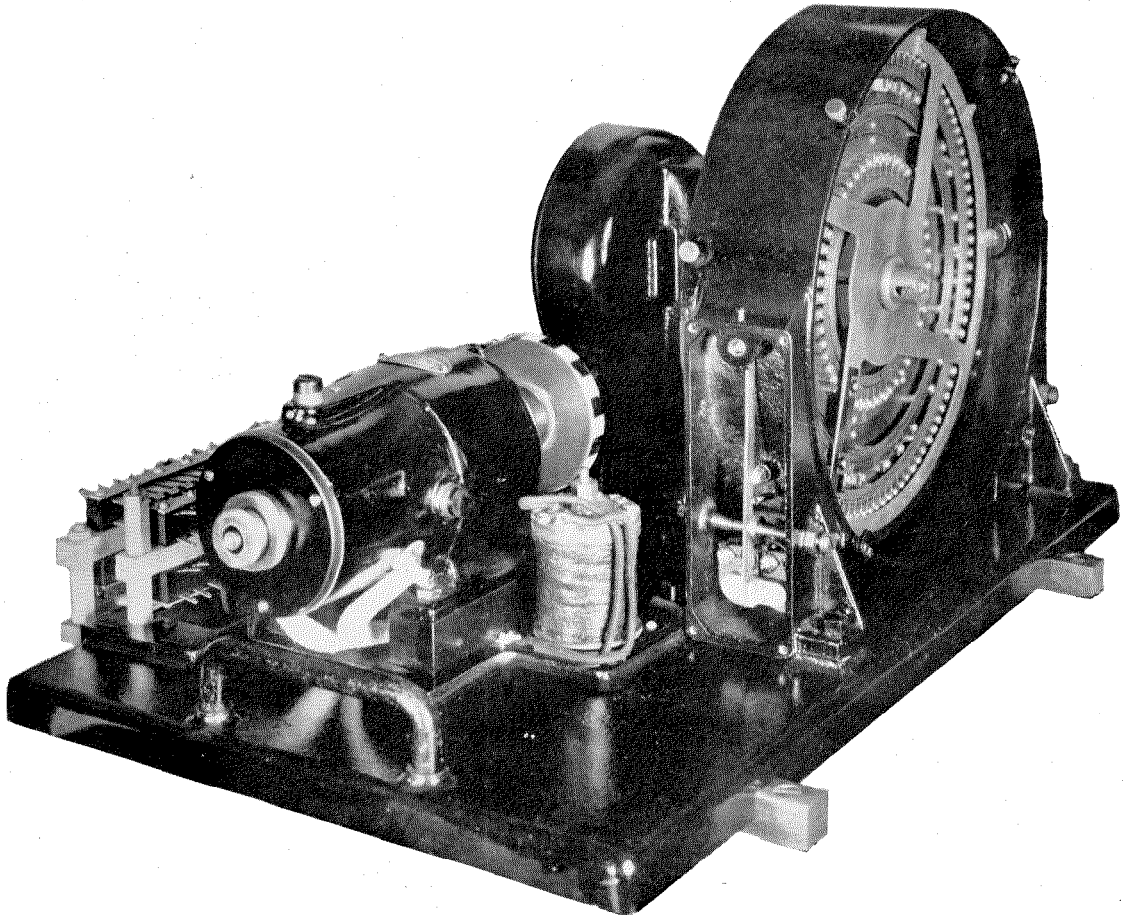

Figure 1—Distributor System for Control and Indication

of effort and to permit prompt action in emergencies.

Nowhere are the possible advantages of centralization greater than in power distribution networks. Power is often drawn from several distinct sources and is utilized or transformed at a number of substations, which are usually scattered over a considerable area and have loads that vary greatly in response to

conditions which exist at each substation and should have means under his control to change these conditions at will.

The first requisite for such centralized responsibility is prompt and exact information reported in the clearest and simplest form. The load dispatcher, or whatever his title may be, must know what machines are in operation at the generating stations, what switches are

closed in each substation; in fact, he must have constantly available complete information as to the operating conditions in all parts of the system. Whether he controls directly some or all of the units, or controls these indirectly through instructions to local attendants,

the information must be in such form that he can see at a glance the condition of all units and the relations between them. It is to meet this imperative need that the supervisory system for remote control of power networks has been developed.

Such a system makes it possible for power companies to render to the public, service of efficiency hitherto impossible. Extraordinary loads can be met by promptly bringing into service the reserves of power supply. Trouble in any part of the system is immediately indicated and the load dispatcher can, without delay, start the repair forces to work. In times of fire or similar emergencies, power

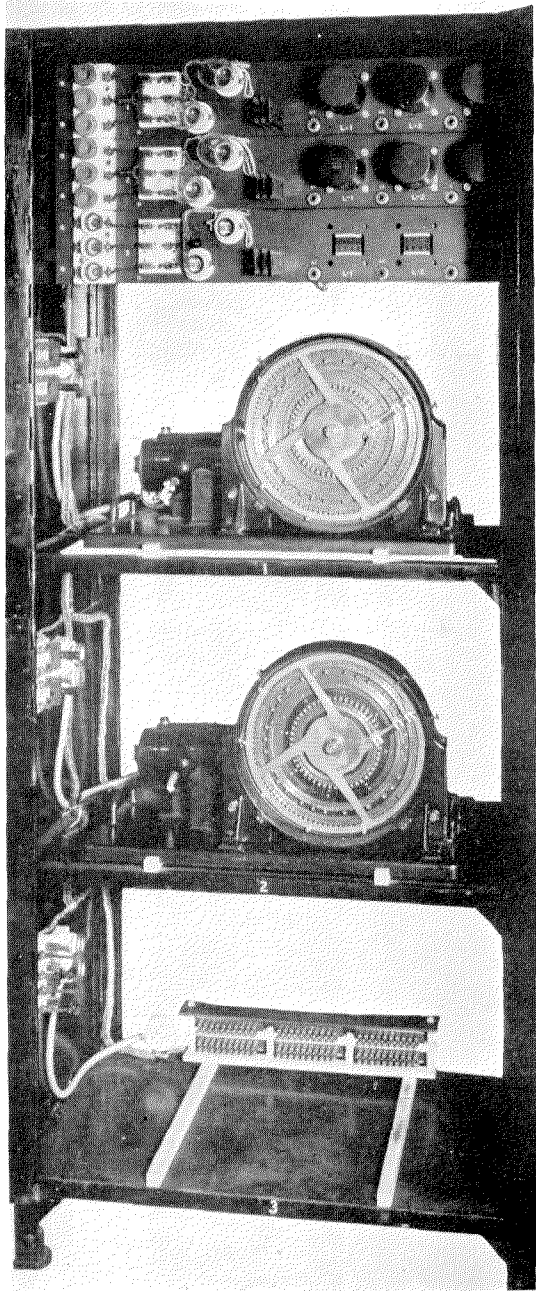

Figure 1A—Distributor System—Apparatus Cabinet for Three Distributors and Associated Relays Used When Indications Only are Required—Capacity for Indications of 300 Switches

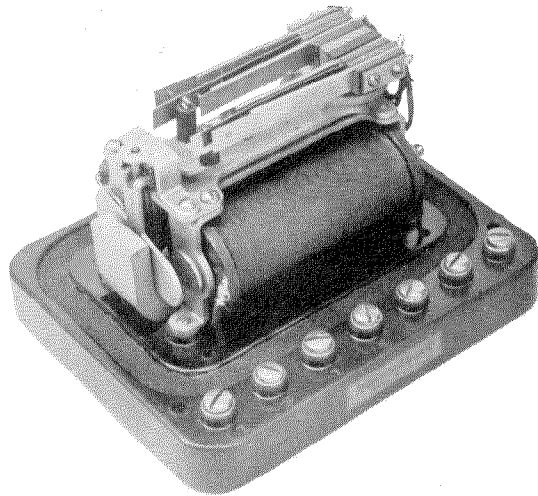

Figure 1B—Distributor, Selector and Cable Systems—Polar Relay. Two Position Relay, Remaining in Position Last Operated. Used in All Systems to Light the Red and Green Lamp at Dispatcher Station and to Open or Close Each Switch at Distant Station

can be disconnected from the affected area. Under normal conditions the service can be kept always at the peak of efficiency through the fact that the load dispatcher who is responsible for such efficiency is kept constantly informed of the operating conditions on the entire system.

In addition to its service of centralized operating information, the supervisory system performs that of centralized control. With such control, the load dispatcher can, by throwing a key at his desk, open or close any individual switch or circuit breaker, start or stop any of the machines and receive back

instantly a signal that the operation is complete. Not only does such arrangement eliminate the necessity for attendance at outlying stations but it speeds up operation and reduces the possibility of errors which might occur in transmitting verbal instructions to attendants.

Also in the case of automatic substations, means are provided for taking the control away from the automatic apparatus in case of emergency.

The apparatus employed is partly new,

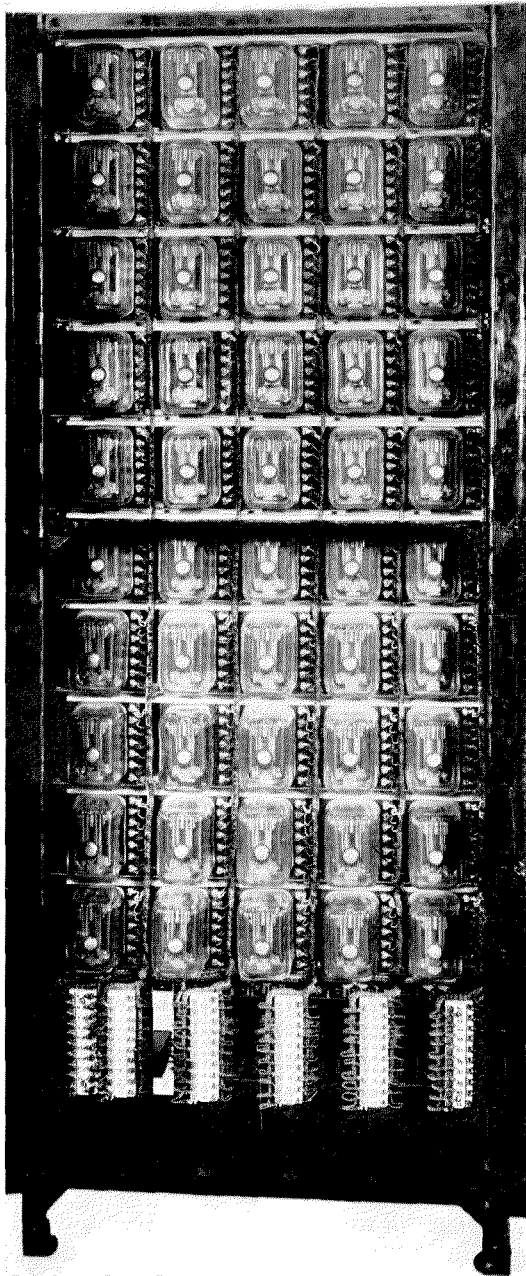

Figure 1C—Distributor and Cable Systems—Relay Cabinet, Contains 100 Polar Relays, Used When Indications Only are Required—Capacity for 100 Switches

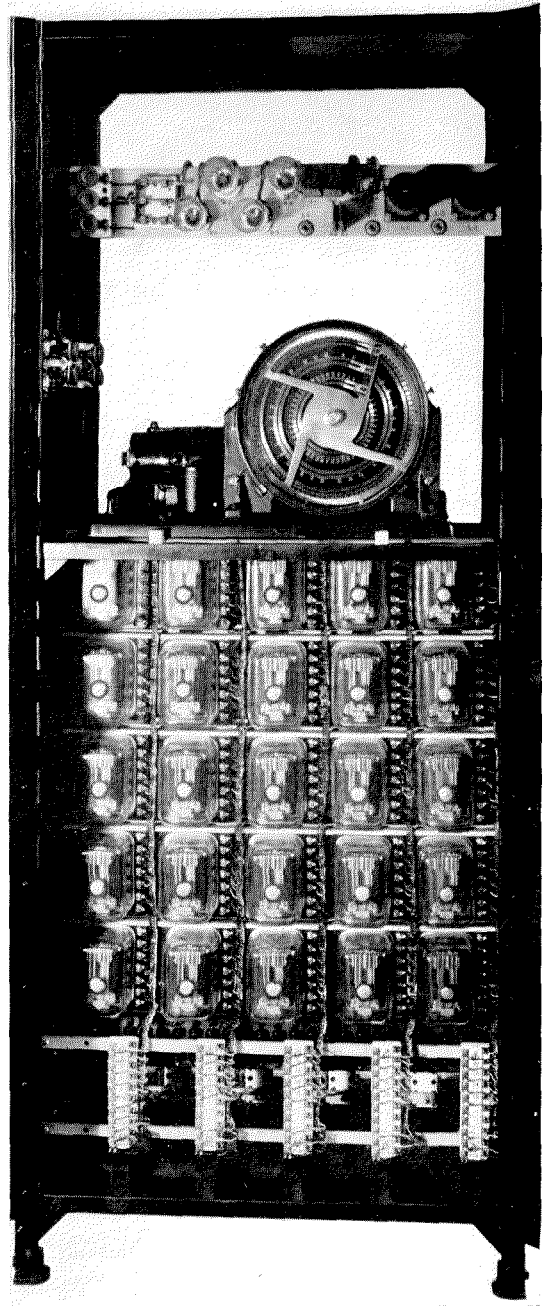

Figure 1D—Distributor System for Control and Indication—Distributor Apparatus Cabinet. Contains all Apparatus Required at Each Station, Including One Distributor and Fifty Polar Relays, for the Supervision of Fifty Switches, etc.

partly adapted from other fields of communication where, by years of successful service, it has demonstrated its reliability under the most exacting operating conditions.

In the development of this system there was kept constantly in mind, that it was essen-

To open or close a switch or circuit breaker the dispatcher has only to turn the key corresponding to that switch. The completion of the operation thus initiated causes the green or red lamp associated with the key to light. In addition to the lamp indication,

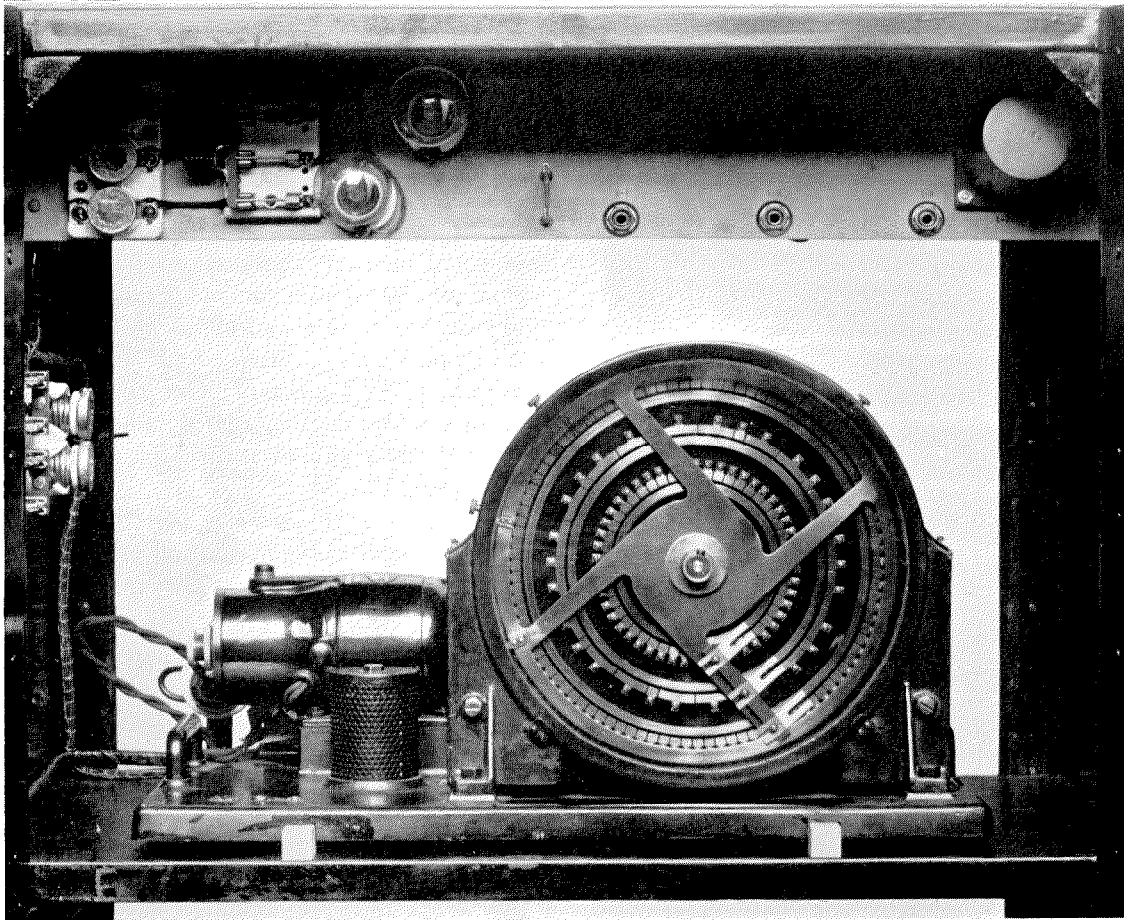

Figure 1E—Distributor Cabinet—Used When Only Indications are Required—Capacity for 100 Switches

tial for both the circuits and apparatus employed to conform at least in a general way to the practices already well established for power generation and transmission. As a result the operating condition of the entire system is constantly displayed before the dispatcher by the standard method of red and green indicating lamps. These lamps show the condition of all of the power apparatus whether controlled from an outlying station or controlled directly from the central power station.

a short bell signal attracts attention to the fact that there has been a change in the position of the apparatus.

Though employing in all cases the key-lamp system of control and indication, the supervisory control equipment has been developed in three distinct types to meet three different operating conditions as follows:

- 1—Where a large number of generating units or switches are installed in an out-

lying station located at a considerable distance from the load dispatcher's control station. This condition is met by employing a system of motor driven distributors and associated apparatus employing four line wires to connect the central

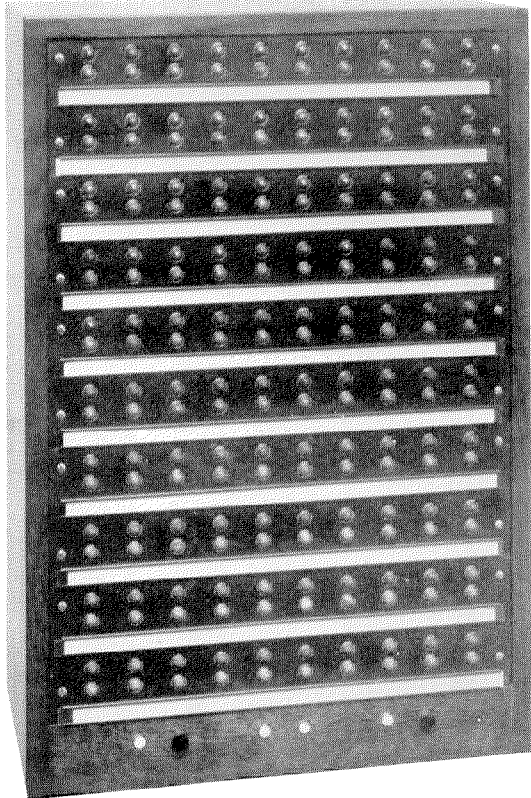

Figure 1F—Distributor and Cable Systems—For Indication Only—Dispatcher's Lamp Cabinet—Contains a Red and Green Lamp for Switch Indicated. Used When Indications Only are Required—Capacity for 100 Switches

station to the outlying station, Figures 1, 1A, 1B, 1C, 1D, 1E, 1F and 1G.

2—Where the power system is composed of a number of scattered generating or switching stations, each requiring only a small number of operations. This condition is met by a system using selectors, selector keys and motor driven selector keys employing three line wires to connect the central station to the outlying stations, Figures 2, 2A, 2B, 2C, 2D, 2E and 2F.

3—Where the outlying stations are located so close to the central station

that it is preferable to install telephone cable containing the one or two wires needed for each switch rather than to employ the selector or distributor system. Figures 1B, 1C, 1F and 1G. This system is known as the cable system.

To meet the conditions outlined in paragraph 1, the circuit shown in Figure 3 and the motor driven distributor shown in Figure 1 have been developed. The distributor is for the purpose of minimizing the number of line wires between the stations and at the same time allowing the transmission of 50 control and 50 indicating impulses in a predetermined sequence so that four wires take the place of 100 connecting line wires between the stations for the supervision of 50 power units. Thus only four line wires are necessary for this system between the dispatcher's station and the outlying station. These consist of: One control circuit, one indicating circuit, one synchronizing circuit and one common return for each pair of distributors.

The distributor consists of three sets of insulated metallic segments and collector rings secured to a fibre face. The collector rings

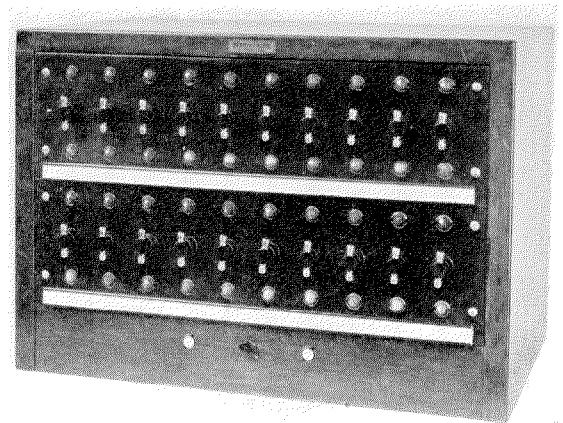

Figure 1G—Distributor and Cable Systems—For Control and Indication—Dispatcher's Control Cabinet. Contains One Key and Two Lamps for Each Switch to be Supervised

are traversed by three pairs of brushes mounted on a brush arm, which is attached to the distributor jack shaft by a friction disc clutch. The jack shaft is driven by a 115-volt DC motor through a worm reduction gear. The inner and outer sets of segments are used for

sending and receiving the control and indicating impulses respectively. The center set of segments is used to assure synchronous operation of the distributor brush arms by sending a series of positive and negative impulses over one line wire and through the

windings of the release magnets on the distributors at the opposite ends of the line. The release magnets being in series, operate and release the brush arm of each distributor simultaneously. Since the teeth on the brush arm are in alignment with the control segments, the release magnet will be energized before the brush carrier teeth engage with the latches, provided the distributors are operating synchronously. However, if the two distributors are not operating synchronously, the brush arm which is running the faster will be stopped at the release magnet latch and held until the slower arm reaches the corresponding position thus bringing the two arms into step again.

With the pair of distributors operating as described above, positive or negative current originating at the dispatcher's key will be transmitted to each of the 50 sending segments and over the connecting line wires in succession to the receiving relay at the distant station. The receiving relays being polarized will take a position corresponding to the impulses received from the sending keys at the dispatcher's station as the brushes pass over the corresponding segments of the distributors. Each supervised unit at the distant station is provided with an auxiliary switch operated in either one of two positions by the functioning of the equipment to which it is attached. In this way positive or negative current from a local battery is placed on each of the 50 sending segments of the distributor at the distant station in the same manner as that described for the operation of the keys at the dispatcher's station. The impulses which result, reach the dispatcher's station over a separate line wire and operate the receiving relays at that station to change the indication given by the red or green lamp to indicate the position of each switch.

Any break in the line wires, failure of the distributors or of the battery supply is shown by indicating lamps located in the dispatcher's lamp cabinet, Figures 1F and 1G. The distributor supervisory system has incorporated in its design an automatic checking feature. This checks every five seconds the position of every device which is supervised so that the dispatcher can be confident that the indica-

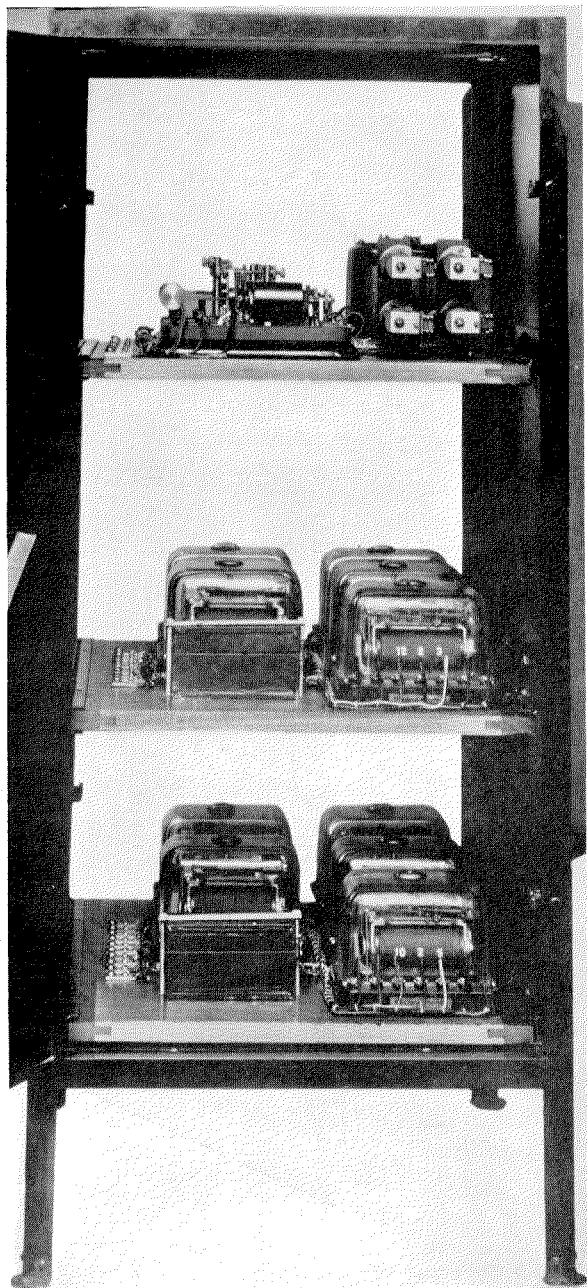

Figure 2—Selector System, Dispatcher's Station Equipment—Apparatus Cabinet—Contains all Equipment at Dispatcher's Station—Consisting of One Control Shelf and Two Indication Shelves for the Control and Indication of Eight Switches

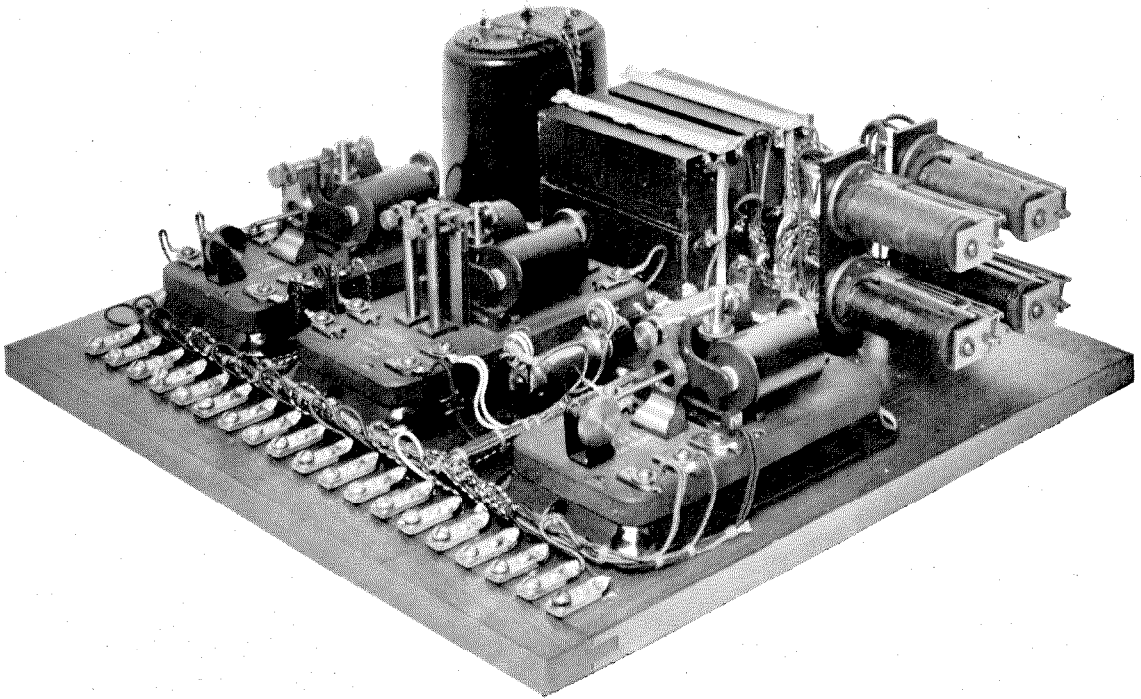

Figure 2A—Selector System, Dispatcher's Station Equipment—Control Shelf—Contains all Common Apparatus Required for the System at Dispatcher's Station

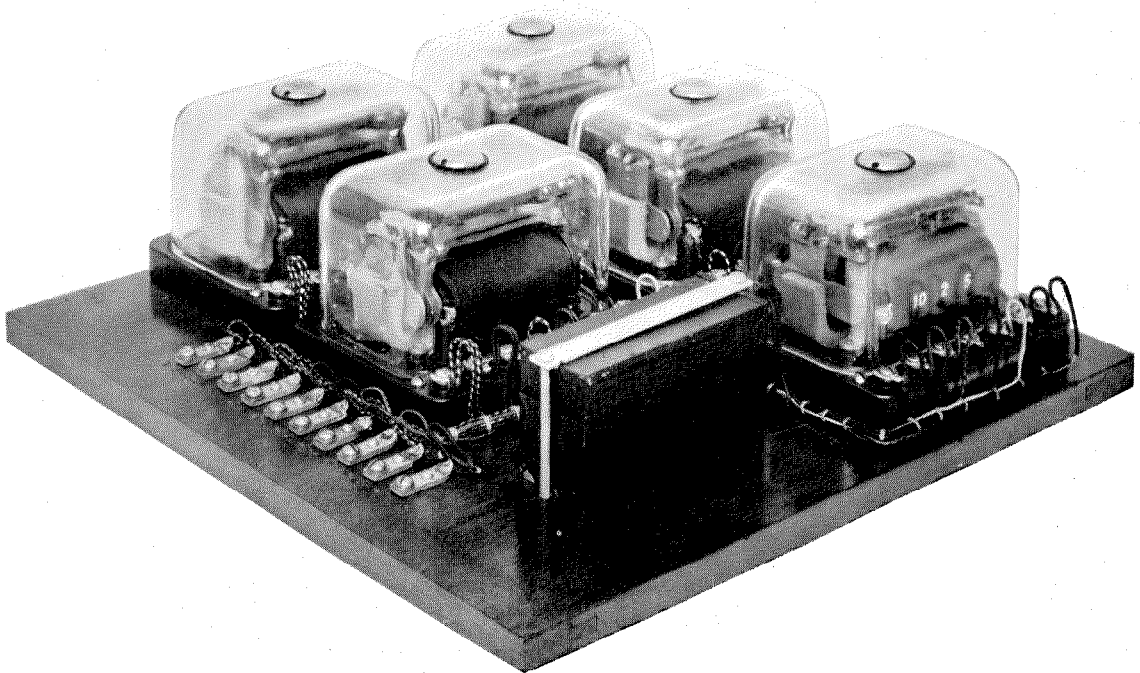

Figure 2B—Selector System, Dispatcher's Station Equipment—Indication Shelf—Contains the Receiving Apparatus Required for the Indication of Four Switches

tions shown on his indicating board are correct to within five seconds. This, of course, relieves him of a great deal of mental anxiety and the necessity for checking the switches from time to time.

For power networks consisting of a dispatcher's station and a number of widely scattered distant stations, the selector system is used, the stations being connected by three line wires which run continuously through the entire system.

one red and one green for each unit supervised. The key on the left hand side in each case starts the unit or closes the switch and the key on the right hand side stops the unit or opens the switch. The red lamp indicates that the switch is closed and the green lamp that the switch is open.

This arrangement enables the operator to control all of the apparatus at the outlying stations and to know when a switch changes

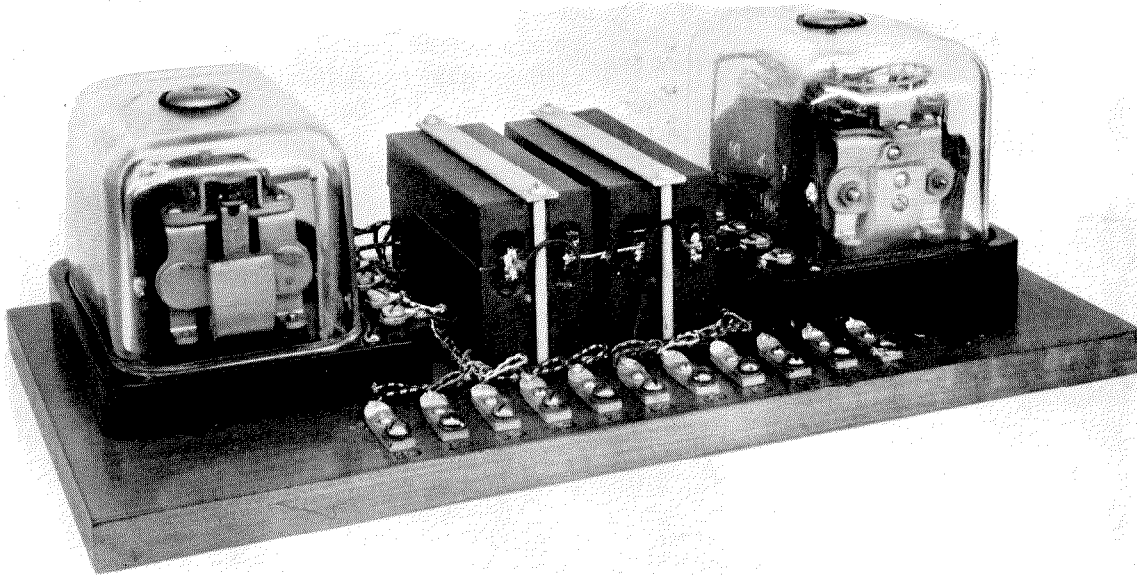

Figure 2C—Selector System, Distant Station Equipment—Selector Shelf—Contains Apparatus at Distant Station for Selection of Four Power Units to be Operated

The control feature for operating the power units is an adaptation of the standard calling circuit used in train dispatching systems. To operate the red and green lamps, however, there is employed an automatic motor driven four-unit selector key, Figure 2F. This device is capable of sending in eight indications for the "open" or "closed," "start" or "stop" positions of four power units. The motor is of the 24-volt direct current type and is operated whenever an indication is to be sent in to the dispatcher's office.

In this system also the dispatcher has constantly before him a visual indication of the position of each power unit. In the dispatcher's lamp and key cabinet, Figure 2E there are two keys and two indicating lamps,

in position due either to his operating a key or to a switch operating from overload, etc. When a control key is operated, a train of impulses is sent out to the outlying station and the selector having the same code setting as that of the sending key moves to the operating point and closes a contact, which energizes the auxiliary relay governing the operation of the associated power unit. By means of an auxiliary contact, the operation of this power unit starts one of the automatic motor driven keys and releases a corresponding code wheel. This code wheel sends a series of impulses to the dispatcher's station and steps up the corresponding selector to the operating point, energizing a local relay and lighting the corresponding lamp for that unit.

The equipment is so arranged that but one indication can be sent in at a time and that

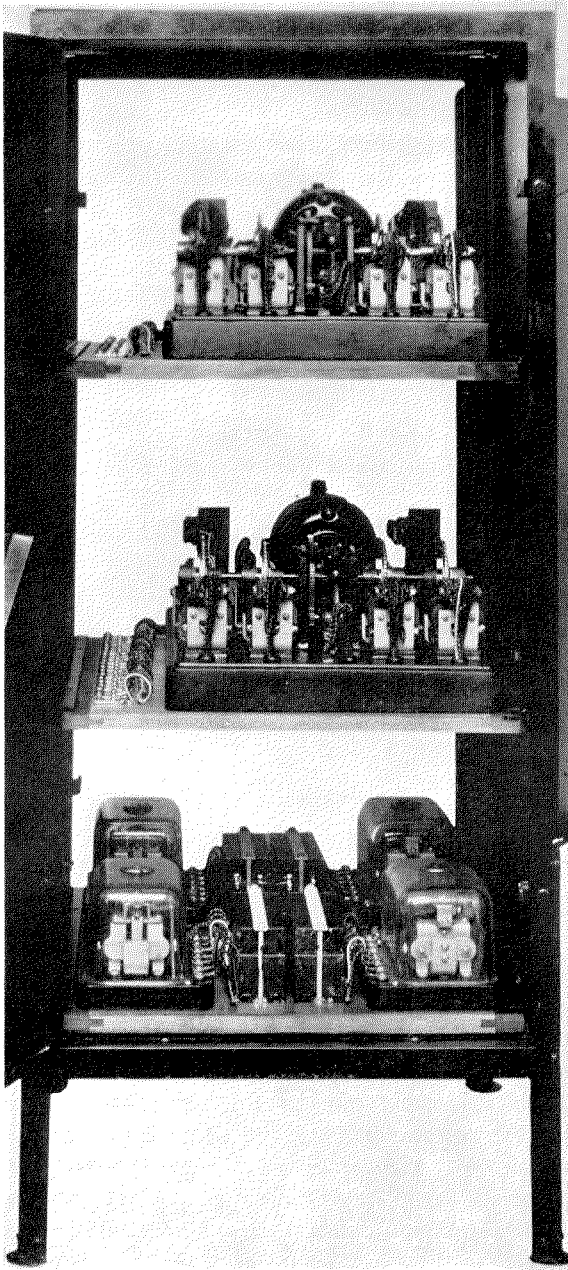

Figure 2D—Selector System, Distant Station Equipment—Apparatus Cabinet—Contains all Apparatus at Distant Station, Consisting of Two Motor Keys and Two Selector Shelves for the Control and Indication of Eight Switches

no incoming signals from any unit can be sent in while the dispatcher is operating any control key. If several circuit breakers within the same station or in different stations should open simultaneously the indications are held and sent in to the dispatcher's office in a definite order.

For use where the central station and the outlying stations are not far apart there was developed a system employing, instead of the two distributors, multiple conductor lead covered telephone cable. This system requires one wire per switch for control and one wire per switch for indication and one common return wire if a battery is used at each station. If a battery is provided at only one station two additional wires are required. Except for the distributors the terminal apparatus at both stations is exactly the same as that used with the distributor system.

Since the supervisory systems will be needed most when trouble is occurring in the power networks, the systems are designed to use a separate power source. The potentials required for the operation of the distributor system are derived from 120-volt motor generators or batteries installed at both ends of the system. A center tap is connected to either set of batteries to supply 60 volts positive and 60 volts negative. The batteries required to operate the selector system are one 144-volt battery at the dispatcher's station and one 48-volt battery divided into two equal parts at each of the outlying stations. In no case does the constant battery drain exceed $1\frac{1}{2}$ ampere. In the cable system, a 120-volt battery with a center tap is required at either the distributor's station or the outlying station or at both stations. In this case the current drain will be .008 ampere for each indication and for each control of the power units. A 24-volt source, either direct or alternating current is used to light the indicating lamps in each of the systems. The current drain is .040 ampere for each pair of lamps connected to the system in this manner.

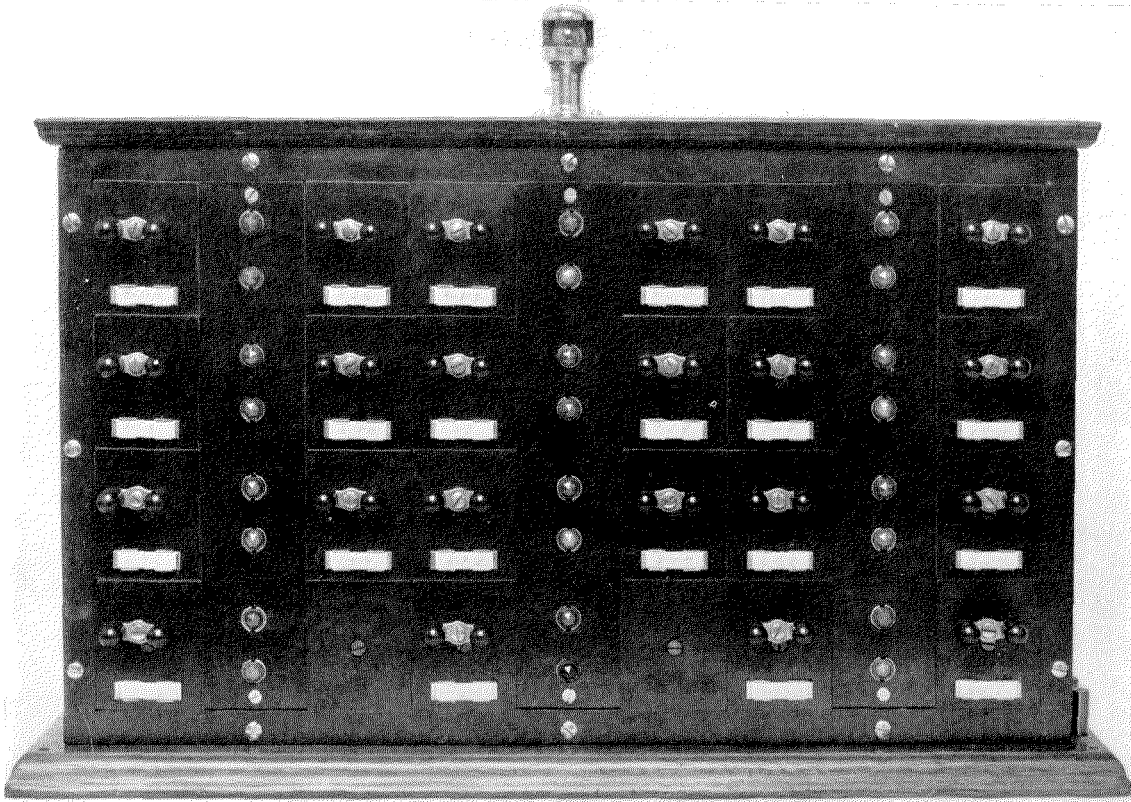

Figure 2E—Selector System, Dispatcher's Station Equipment—Key and Lamp Cabinet Located on Dispatcher's Desk. Contains Two Keys and Two Lamps for Each Unit Supervised. One of These Keys Will Open While the Other Will Close a Circuit Breaker. One Lamp (Green) Indicates the Open Position, the Other Lamp (Red) Indicates the Closed Position of the Unit Supervised

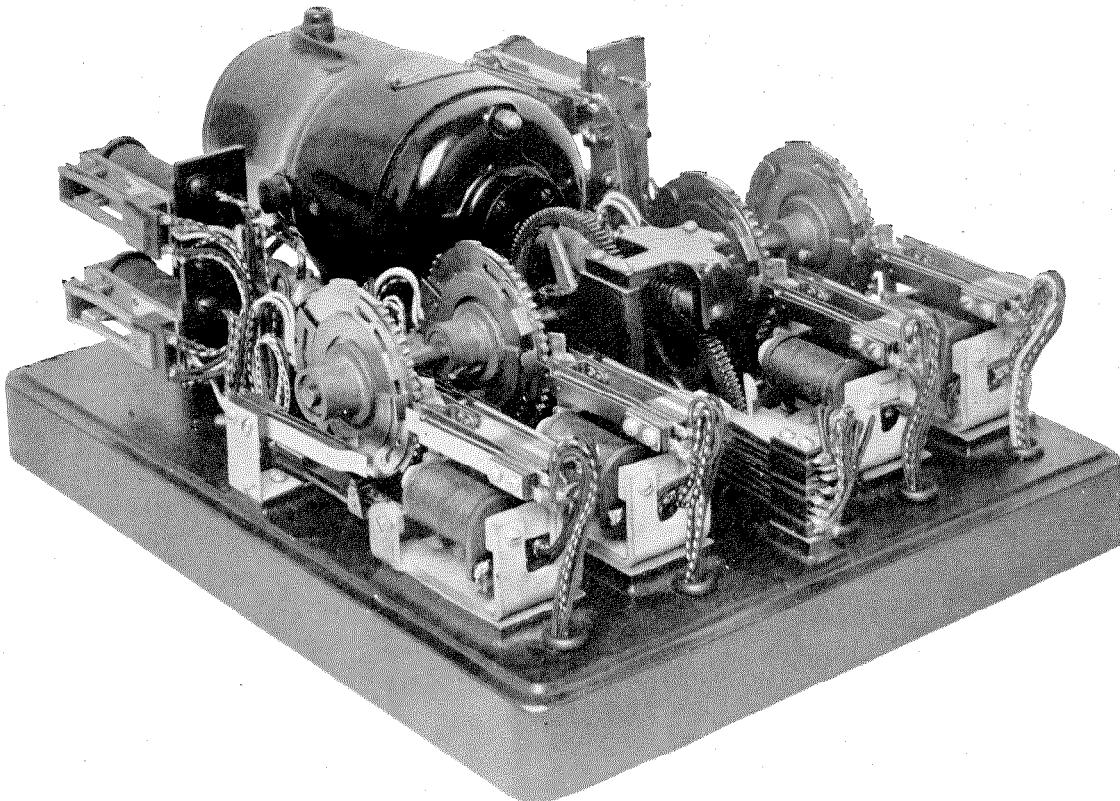

Figure 2F—Selector System, Distant Station Equipment—Motor Key—Contains Apparatus for Sending of Coded Impulses from Four Power Units to Indicate their Position

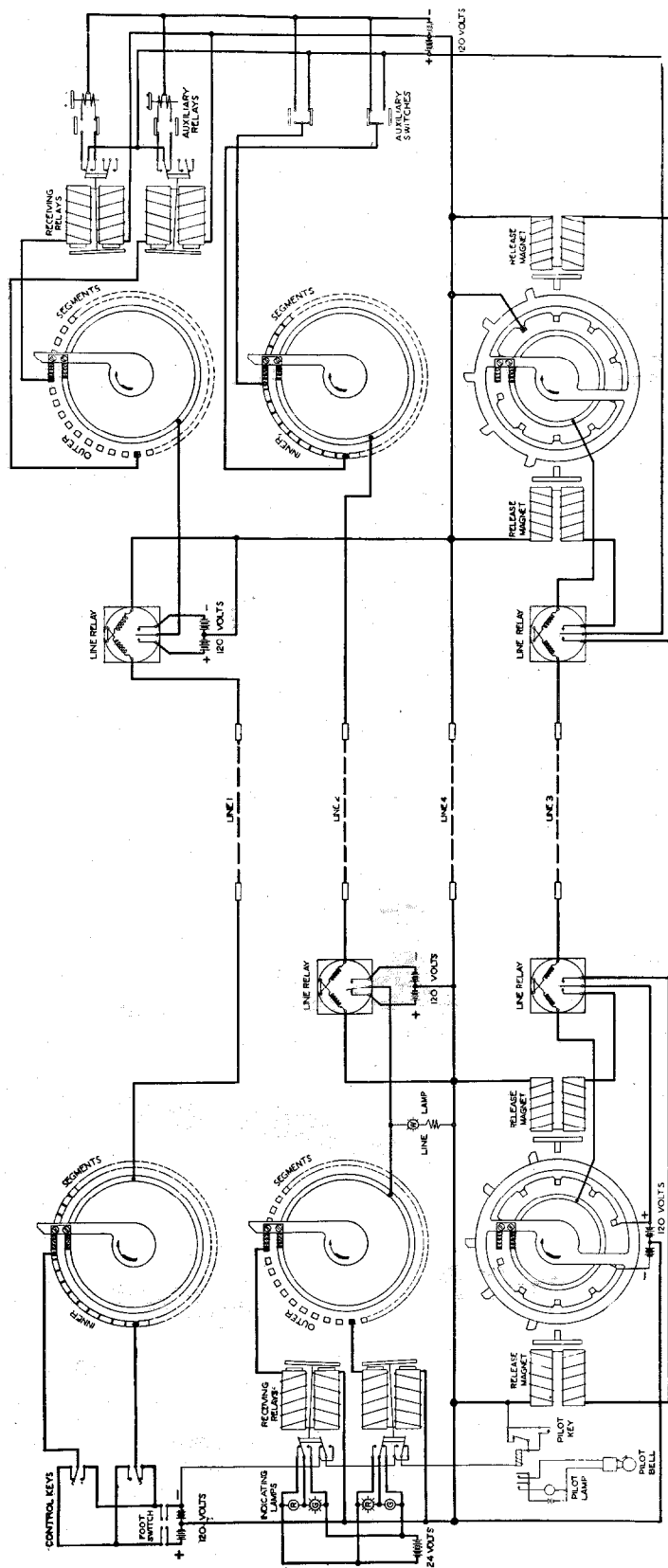

Figure 3—Distributor Supervisory System

Telephone and Telegraph Statistics of the World

Compiled by Chief Statistician's Division, American Telephone and Telegraph Company

Telephone Development of the World, by Countries

January 1, 1923

	Number of Telephones			Per Cent of Total World	Telephones Per 100 Population	Increase in Number of Telephones During 1921†
	Government Systems	Private Companies	Total			
NORTH AMERICA:						
United States.....		14,347,395	14,347,395**	62.64%	13.1	620,670
Canada.....	196,800	747,229	944,029	4.12%	10.4	41,939
Central America.....	6,718	10,427	17,145	.07%	0.3	568
Mexico.....	1,860	45,069	47,929	.21%	0.4	2,513
West Indies:						
Cuba.....	500	41,047	41,547	.18%	1.4	3,509
Porto Rico.....	615	9,756	10,371	.05%	0.8	1,269
Other W. I. Places*.....	3,589	8,332	11,921	.05%	0.2	1,021
Other No. Am. Places*.....	60	3,500	3,500	.02%	1.0	110
Total.....	210,142	15,213,755	15,423,897	67.34%	10.4	671,599
SOUTH AMERICA:						
Argentina.....		143,093	143,093	.63%	1.6	12,366
Bolivia.....		2,706	2,706	.01%	0.1	97
Brazil.....	598	89,514	90,112	.39%	0.3	2,526
Chile.....		30,520	30,520	.13%	0.8	859
Colombia.....		9,958	9,958	.04%	0.2	2,657
Ecuador.....	1,675	2,605	4,280	.02%	0.2	244
Paraguay.....	90	341	431	.002%	0.04	25
Peru.....	2	8,917	8,919	.04%	0.2	298
Uruguay.....		24,397	24,397	.11%	1.6	349
Venezuela.....	444	9,882	10,326	.05%	0.4	1,145
Other Places.....	2,226		2,226	.01%	0.5	93
Total.....	5,035	321,933	326,968	1.43%	0.5	20,659
EUROPE:						
Austria.....	133,400		133,400	.58%	2.0	1,100
Belgium.....	96,516		96,516	.42%	1.3	16,007
Bulgaria.....	7,052		7,052	.03%	0.1	452
Czecho-Slovakia.....	84,330		84,330	.37%	0.6	2,377
Denmark.....	9,407*	267,182	276,589	1.21%	8.3	8,000*
Finland.....		70,500	70,500	.31%	2.1	500
France.....	524,592		524,592	2.29%	1.3	11,285
Germany.....	2,073,308		2,073,308	9.05%	3.5	127,707
Great Britain and No. Ireland.....	1,045,928		1,045,908	4.57%	2.3	48,123
Greece.....	5,357		5,357	.02%	0.1	357
Hungary.....	70,816		70,816	.31%	0.9	8,316
Irish Free State (March 31, 1923).....	19,610		19,610	.09%	0.6	#
Italy (June 30, 1922)*.....	86,100	39,000	125,100	.55%	0.3	5,000
Jugo-Slavia.....	24,178		24,178	.10%	0.2	2,480
Netherlands.....	184,113	1,009	185,122	.81%	2.6	9,098
Norway (June 30, 1922).....	91,524	66,786§	158,310	.69%	5.8	5,968
Poland.....	60,629	38,964	99,593	.43%	0.4	21,674
Portugal.....	2,000*	15,987	17,987	.08%	0.3	1,278
Roumania (March 31, 1923)*.....	31,100		31,100	.14%	0.2	1,500
Russia†.....	112,000		112,000	.49%	0.1	-58,741
Spain.....	23,536	58,414	81,950	.36%	0.4	#
Sweden.....	392,815	1,720	394,535	1.72%	6.6	8,932
Switzerland.....	167,440		167,440	.73%	4.3	5,735
Other Places in Europe*.....	47,393	10,978	58,371	.25%	0.6	11,662
Total.....	5,293,144	570,540	5,863,684	25.60%	1.2	243,000
ASIA:						
British India (March 31, 1923).....	13,337	25,590	38,927	.17%	0.01	2,570
China*.....	63,552	28,218	91,770	.40%	0.03	8,334
Japan.....	519,630		519,630	2.27%	0.9	94,593
Other Places in Asia*.....	60,327	13,822	74,149	.32%	0.05	13,720
Total.....	656,846	67,630	724,476	3.16%	0.1	119,217
AFRICA:						
Egypt.....	28,358		28,358	.12%	0.1	3,173
Union of South Africa¶.....	60,210		60,210	.26%	0.8	4,129
Other Places in Africa*.....	39,253	1,130	40,383	.18%	0.03	5,000
Total.....	127,821	1,130	128,951	.56%	0.1	12,302
OCEANIA:						
Australia (June 30, 1922).....	258,477		258,477	1.13%	4.6	17,970
Dutch East Indies*.....	36,000	2,000	38,000	.17%	0.1	1,159
Hawaii.....		16,074	16,074	.07%	5.8	950
New Zealand (March 31, 1923).....	107,036		107,036	.47%	8.1	12,353
Philippine Islands*.....	2,310	11,900	14,210	.06%	0.1	680
Other Places in Oceania*.....	2,218	424	2,642	.01%	0.1	272
Total.....	406,041	30,398	436,439	1.91%	0.6	33,384
TOTAL WORLD.....	6,699,029	16,205,386	22,904,415	100.00%	1.3	1,100,161

* Partly estimated. † Minus sign preceding a figure denotes decrease. ¶ March 31, 1923.
 # Accurate data not available, and basis for reliable estimate lacking. An arbitrary estimate, however, is included in total for Europe.
 § January 1, 1923. ‡ Including Siberia. ** As reported by the United States Department of Commerce, Bureau of the Census.

Telephone and Telegraph Wire of the World, by Countries January 1, 1923

	Service Operated by (See Note)	Miles of Telephone Wire			Miles of Telegraph Wire (See Note)		
		Number of Miles	Per Cent of Total World	Per 100 Population	Number of Miles	Per Cent of Total World	Per 100 Population
NORTH AMERICA:							
United States.....	P.	37,265,958	60.67%	33.9	1,845,000	29.35%	1.7
Canada.....	P. G.	2,396,805	3.90%	26.5	262,343	4.17%	2.9
Central America.....	P. G.	34,038	.05%	0.6	21,662	.34%	0.4
Mexico.....	P. G.	121,169	.20%	0.9	78,539	1.25%	0.6
West Indies:							
Cuba.....	P. G.	115,137	.19%	3.8	15,248	.24%	0.5
Porto Rico.....	P. G.	13,719	.02%	1.0	998	.02%	0.1
Other W. I. Places*.....	P. G.	26,311	.04%	0.5	4,975	.08%	0.1
Other No. Am. Places*.....	P. G.	6,800	.01%	2.0	9,350	.15%	2.7
Total.....		39,979,937	65.08%	27.3	2,238,115	35.60%	1.5
SOUTH AMERICA:							
Argentina.....	P.	416,140	.68%	4.6	174,426	2.77%	1.9
Bolivia.....	P.	3,254	.01%	0.1	6,957 [#]	.11%	0.2
Brazil.....	P. G.	240,552	.39%	0.8	94,045	1.50%	0.3
Chile.....	P.	48,487	.08%	1.2	38,203	.61%	1.0
Colombia.....	P.	14,974	.02%	0.2	14,233	.23%	0.2
Ecuador.....	P. G.	5,048	.01%	0.2	4,622 [§]	.07%	0.2
Paraguay.....	P. G.	138	.0002%	0.01	1,841	.03%	0.2
Peru.....	P.	32,180	.05%	0.6	10,401	.17%	0.2
Uruguay.....	P.	45,593	.07%	2.9	5,029	.08%	0.3
Venezuela.....	P. G.	24,414	.04%	0.9	6,240 [§]	.10%	0.2
Other Places.....	G.	3,273	.01%	0.7	770 [§]	.01%	0.2
Total.....		834,053	1.36%	1.2	356,767	5.68%	0.5
EUROPE:							
Austria.....	G.	341,140	.55%	5.2	45,966	.73%	0.7
Belgium.....	G.	394,704	.64%	5.2	27,742	.44%	0.4
Bulgaria.....	G.	25,239	.04%	0.5	15,011	.24%	0.3
Czecho-Slovakia.....	G.	151,746	.25%	1.1	45,177	.72%	0.3
Denmark.....	P. G.	634,684	1.03%	19.0	9,500	.15%	0.3
Finland.....	P.	84,094	.14%	2.4	10,097	.16%	0.3
France*.....	G.	1,527,000	2.49%	3.9	490,000	7.80%	1.2
Germany.....	G.	5,980,368	9.74%	10.1	480,653	7.65%	0.8
Great Britain and No. Ireland†.....	G.	4,123,622	6.71%	9.1	280,005	4.45%	0.6
Greece.....	G.	5,618	.01%	0.1	20,341	.32%	0.4
Hungary.....	G.	200,825	.33%	2.5	51,048	.81%	0.6
Irish Free State†.....	G.	50,908	.08%	1.6	21,995	.35%	0.7
Italy (June 30, 1922)*.....	P. G.	365,000	.59%	0.9	252,000	4.01%	0.6
Jugo-Slavia.....	G.	54,886	.09%	0.5	35,378	.56%	0.3
Netherlands.....	G.	379,126 [#]	.62%	5.3	32,495	.52%	0.5
Norway (June 30, 1922).....	P. G.	353,702	.57%	13.0	19,540	.31%	0.7
Poland.....	P. G.	370,845	.60%	1.4	103,567	1.65%	0.4
Portugal*.....	P. G.	58,748	.10%	0.9	18,300	.29%	0.3
Roumania (March 31, 1923)*.....	G.	67,400	.11%	0.4	47,000	.75%	0.3
Russia.....	G.	590,678	.96%	0.4	412,495	6.56%	0.3
Spain.....	P. G.	163,900 [#]	.27%	0.7	79,703	1.27%	0.4
Sweden.....	G.	852,556	1.39%	14.2	50,879	.81%	0.8
Switzerland.....	G.	410,955	.67%	10.5	27,050	.43%	0.7
Other Places in Europe*.....	P. G.	144,891	.24%	1.4	23,433	.37%	0.2
Total.....		17,332,635	28.22%	3.7	2,599,377	41.35%	0.5
ASIA:							
British India†.....	P. G.	174,265	.28%	0.06	357,259	5.68%	0.1
China*.....	P. G.	98,480	.16%	0.03	82,950	1.32%	0.03
Japan*.....	G.	1,030,000	1.68%	1.8	152,000	2.42%	0.3
Other Places in Asia*.....	P. G.	183,806	.30%	0.1	167,224	2.66%	0.1
Total.....		1,486,551	2.42%	0.2	759,433	12.08%	0.1
AFRICA:							
Egypt.....	G.	98,069	.16%	0.5	20,751	.33%	0.1
Union of South Africa†.....	G.	174,132	.28%	2.4	45,526	.72%	0.6
Other Places in Africa*.....	P. G.	83,325	.14%	0.07	116,833	1.86%	0.1
Total.....		355,526	.58%	0.2	183,110	2.91%	0.1
OCEANIA:							
Australia (June 30, 1922).....	P. G.	966,235	1.57%	17.4	95,272	1.51%	1.7
Dutch East Indies*.....	P. G.	130,000	.21%	0.3	21,200	.34%	0.04
Hawaii.....	P.	52,808	.09%	19.2	0	.00%	0.0
New Zealand†.....	G.	258,228	.42%	19.5	23,250	.37%	1.8
Philippine Islands.....	P. G.	27,000 [#]	.04%	0.3	8,744	.14%	0.1
Other Places in Oceania*.....	P. G.	5,085	.01%	0.3	1,371	.02%	0.1
Total.....		1,439,356	2.34%	2.1	149,837	2.38%	0.2
TOTAL WORLD.....		61,428,058	100.00%	3.5	6,286,639	100.00%	0.4

Note: Telegraph service is operated by Governments, except in the United States and Canada. In connection with telephone wire, P. indicates telephone service operated by private companies, G. by the Government, and P. G. by both private companies and the Government.

* Partly estimated.

[#] January 1, 1920.

[§] January 1, 1922.

† March 31, 1923.

Telephone Development of Important Cities January 1, 1923

Country and City (or Exchange Area)	Estimated Population (City or Exchange Area)	Number of Telephones	Telephones per 100 Population
ARGENTINE:			
Buenos Aires.....	1,720,000	76,186	4.4
AUSTRALIA:			
Adelaide.....	270,000	18,228	6.7
Brisbane.....	230,000	14,300	6.2
Melbourne.....	817,000	54,081	6.6
Sydney.....	956,000	66,545	7.0
AUSTRIA:			
Gratz.....	160,000	5,600	3.5
Vienna.....	1,860,000	86,000	4.6
BELGIUM:			
Antwerp.....	468,000	14,794	3.2
Brussels.....	872,000	33,479	3.8
Charleroi.....	206,000	3,212	1.6
Ghent.....	279,000	4,392	1.6
Liege.....	301,000	7,248	2.4
CANADA:			
Montreal.....	892,000	92,376	10.4
Ottawa.....	167,000	27,279	16.3
Toronto.....	583,000	112,211	19.2
CHINA:			
Canton.....	909,000	2,570	0.3
Shanghai.....	1,515,000	18,351	1.2
Tientsin.....	808,000	7,062	0.9
Peking.....	1,313,000	32,000*	2.4
CUBA:			
Havana.....	465,000	30,436	6.5
CZECHO-SLOVAKIA:			
Prague.....	683,000	22,296	3.3
DANZIG, FREE CITY OF:			
	365,000	13,075	3.6
DENMARK:			
Copenhagen.....	729,000	105,851	14.5
FRANCE:*			
Bordeaux.....	270,000	8,700	3.2
Lille.....	203,000	5,600	2.8
Lyons.....	568,000	12,000	2.1
Marselles.....	592,000	13,000	2.2
Paris.....	2,935,000	185,000	6.3
GERMANY:			
Berlin.....	3,842,000	357,062	9.3
Bremen.....	273,000	22,361	8.2
Breslau.....	533,000	31,168	5.8
Chemnitz.....	307,000	16,442	5.4
Cologne.....	640,000	41,748	6.5
Dresden.....	594,000	38,437	6.5
Düsseldorf.....	411,000	29,657	7.2
Essen.....	443,000	17,441	3.9
Frankfort-on-Main.....	437,000	40,622	9.3
Hamburg-Altona.....	1,167,000	113,882	9.8
Hanover.....	397,000	25,116	6.3
Leipzig.....	610,000	46,918	7.7
Magdeburg.....	289,000	16,057	5.6
Munich.....	637,000	50,005	7.9
Nuremberg.....	357,000	25,354	7.1
Stuttgart.....	312,000	27,366	8.8
GREAT BRITAIN AND NORTHERN IRELAND:‡			
Belfast.....	418,000	9,500	2.3
Birmingham.....	1,298,000	29,588	2.3
Blackburn.....	254,000	5,338	2.1
Bolton.....	285,000	5,414	1.9
Bradford.....	383,000	13,246	3.5
Bristol.....	413,000	10,780	2.6
Edinburgh.....	428,000	17,353	4.1
Glasgow.....	1,285,000	44,128	3.4
Hull.....	331,000	13,872	4.2
Leeds.....	547,000	14,308	2.6
Liverpool.....	1,214,000	40,700	3.4
London.....	7,210,000	364,494	5.1
Manchester.....	1,623,000	51,644	3.2
Newcastle.....	609,000	14,525	2.4
Nottingham.....	341,000	10,022	2.9
Plymouth.....	235,000	4,298	1.8
Sheffield.....	515,000	12,618	2.5

*Partly estimated.

‡ March 31, 1923.

Telephone Development of Important Cities—(Concluded)

January 1, 1923

Country and City (or Exchange Area)	Estimated Population (City or Exchange Area)	Number of Telephones	Telephones per 100 Population
HUNGARY:			
Budapest.....	935,000	44,095	4.7
Szegedin.....	111,000	2,065	1.9
IRISH FREE STATE:‡			
Dublin*.....	395,000	12,000	3.0
ITALY:†			
Florence.....	249,000	4,684	1.9
Genoa.....	302,000	8,105	2.7
Milan.....	707,000	17,258	2.4
Naples.....	777,000	6,437	0.8
Palermo.....	404,000	2,515	0.6
Rome.....	642,000	14,164	2.2
Turin.....	504,000	7,545	1.5
Venice.....	167,000	2,572	1.5
JAPAN:*			
Kobe.....	643,000	19,700	3.1
Kyoto.....	619,000	18,700	3.0
Nagoya.....	623,000	15,800	2.5
Osaka.....	1,309,000	61,500	4.7
Tokio.....	2,327,000	108,700	4.7
Yokohama.....	435,000	13,000	3.0
JUGO-SLAVIA:*			
Belgrade.....	113,000	3,200	2.8
NETHERLANDS:			
Amsterdam.....	696,000	33,768	4.8
The Hague.....	366,000	25,706	7.0
Rotterdam.....	532,000	26,690	5.0
NEW ZEALAND:‡			
Auckland.....	168,000	14,215	8.5
Christchurch.....	113,000	11,012	9.7
Wellington.....	112,000	15,439	13.8
NORWAY:†			
Bergen.....	96,000	8,662	9.0
Christiania.....	260,000	32,441	12.5
ROUMANIA:*			
Bucharest.....	353,000	9,000	2.5
RUSSIA:			
Kazan.....	158,000	792	0.5
Kharkov.....	310,000	2,096	0.7
Moscow.....	1,511,000	24,950	1.7
Odessa.....	317,000	777	0.2
Petrograd.....	1,071,000	8,966	0.8
SWEDEN:			
Göteborg.....	228,000	25,234	11.1
Malmö.....	115,000	12,938	11.3
Stockholm.....	425,000	107,979	25.4
SWITZERLAND:			
Basel.....	137,000	12,538	9.1
Berne.....	103,000	10,703	10.4
Geneva.....	134,000	14,189	10.6
Zurich.....	199,000	21,583	10.8
UNITED STATES:§			
New York.....	5,884,000	1,072,632	18.2
Chicago.....	2,858,000	638,650	22.3
Total of the 6 cities with over 1,000,000 population.....	14,440,000	2,663,032	18.4
Cincinnati.....	592,000	109,206	18.5
Los Angeles.....	833,000	189,458	22.7
San Francisco.....	687,000	172,742	25.2
Total of the 11 cities with 500,000–1,000,000 population.....	7,514,000	1,261,414	16.8
Washington.....	452,000	103,085	22.8
Minneapolis.....	420,000	101,529	24.2
Denver.....	274,000	62,987	23.0
Omaha.....	210,000	58,826	28.0
Total of the 25 cities with 200,000–500,000 population.....	7,210,000	1,268,747	17.6
Total of the 42 cities with over 200,000 population.....	29,163,000	5,193,193	17.8

§ In addition to New York and Chicago, the largest cities, there are shown, for purposes of comparison with cities in other countries, the total development of all cities in certain population groups and the development of certain representative cities within each group.

*Partly estimated.

‡ March 31, 1923.

† June 30, 1922.

Telephone Development of Large and Small Communities in Important Countries January 1, 1923

Country	Service Operated by (See Note)	Number of Telephones		Telephones per 100 Population	
		In Communities of 100,000 Population and Over	In Communities of less than 100,000 Population	In Communities of 100,000 Population and Over	In Communities of less than 100,000 Population
Australia.....	G.	162,524	107,566	6.7	3.4
Austria.....	G.	91,600	41,800	4.5	0.9
Belgium.....	G.	63,125	33,391	3.0	0.6
Canada.....	P. G.	337,092	606,937	15.3	8.9
Czecho-Slovakia.....	G.	29,494	54,836	3.3	0.4
Denmark.....	P. G.	105,851	170,738	14.5	6.5
France#.....	G.	251,316	261,991	4.1	0.8
Germany.....	G.	1,121,962	951,346	7.4	2.2
Great Britain and Northern Ireland§.....	G.	789,612	261,060	3.3	1.2
Hungary.....	G.	47,506	23,310	4.1	0.3
Italy (June 30, 1922).....	P. G.	72,534	52,566*	1.5	0.1
Japan#.....	G.	256,058	168,979	3.5	0.3
Netherlands.....	G.	97,529	87,593	5.3	1.7
New Zealand (March 31, 1923).....	G.	40,666	66,370	10.3	7.1
Norway (June 30, 1922).....	P. G.	32,441	125,869	12.5	5.1
Poland.....	P. G.	45,395	54,198	2.3	0.2
Russia.....	G.	37,581	74,419	1.1	0.1
Spain.....	P. G.	47,790	34,160	1.8	0.2
Sweden.....	G.	146,151	248,384	19.0†	4.8
Switzerland.....	G.	59,013	108,427	10.3	3.3
United States.....	P.	6,150,785	8,196,610	17.2	11.1

NOTE: P. indicates telephone service operated by private companies, G. by the Government, and P. G. by both private companies and the Government.

§ March 31, 1923.

† The majority of this development is due to Stockholm.

January 1, 1922.

* Partly estimated.

Telephone Conversations and Telegrams in Important Countries Year 1922

Country	Number of Telephone Conversations	Number of Telegrams	Total Number of Wire Communications	Per Cent. of Total Wire Communications		Wire Communications Per Capita		
				Telephone Conversations	Telegrams	Telephone Conversations	Telegrams	Total
Australia†.....	234,605,000	16,296,000	250,901,000	93.5%	6.5%	42.6	3.0	45.6
Austria.....	296,900,000	8,700,000	305,600,000	97.2%	2.8%	45.8	1.3	47.1
Belgium.....	124,507,000	5,390,000	129,897,000	95.9%	4.1%	16.6	0.7	17.3
Czecho-Slovakia.....	176,643,000	5,047,000	181,690,000	97.2%	2.8%	12.9	0.4	13.3
Denmark.....	399,666,000	2,352,000	402,018,000	99.4%	0.6%	120.3	0.7	121.0
France#.....	652,624,000	64,385,000	727,009,000	91.1%	8.9%	17.0	1.7	18.7
Germany.....	2,067,972,000	57,178,000	2,125,150,000	97.3%	2.7%	35.2	1.0	36.2
Gt. Britain and No. Ireland§.....	815,095,000	65,316,000	880,411,000	92.6%	7.4%	18.2	1.4	19.6
Hungary.....	242,351,000	6,590,000	248,941,000	97.4%	2.6%	30.5	0.8	31.3
Italy†.....	309,595,000	20,011,000	329,606,000	93.9%	6.1%	7.7	0.5	8.2
Japan#.....	1,669,364,000	60,670,000	1,730,034,000	96.5%	3.5%	29.7	1.1	30.8
Netherlands*.....	360,861,000	5,820,000	366,681,000	98.4%	1.6%	51.3	0.8	52.1
Norway†.....	282,601,000	4,490,000	287,091,000	98.4%	1.6%	104.5	1.6	106.1
Russia.....	406,000,000	22,888,000	428,888,000	94.7%	5.3%	3.1	0.2	3.3
Sweden.....	557,507,000	4,165,000	561,672,000	99.3%	0.7%	93.4	0.7	94.1
Switzerland.....	127,525,000	3,049,000	130,574,000	97.7%	2.3%	32.7	0.8	33.5
United States.....	19,000,000,000	181,519,000	19,181,519,000	99.1%	0.9%	174.0	1.7	175.7

NOTE: Telephone conversations include local and toll or long distance conversations. Number of telephone conversations in the United States includes completed messages only.

Year ended January 1, 1922.

§ Year ended March 31, 1923.

† Year ended June 30, 1921.

* Partly estimated.

‡ Year ended June 30, 1922.

"CORRECTION"

With reference to the reproduction which appeared in the January, 1924, issue of ELECTRICAL COMMUNICATION, Volume II, Number 3, of Ing. G. Magagnini's article, entitled "The Work of Installation of the Underground Telephone Cable—Milan-Turin-Genoa," it should have been stated that the site-plan on page 192, which we prepared to replace Figure 1 of the original article, was only a diagram and was not intended to be regarded as a map. We regret that the upper line of the site-plan conveys an incorrect impression of the northern boundary of modern Italy.—EDITOR.

International Western Electric Company

INCORPORATED

Head Offices

195 BROADWAY
NEW YORK, U. S. A.

European General Offices

CONNAUGHT HOUSE
ALDWYCH, LONDON, ENGLAND

Affiliated Companies

Western Electric Company, Limited *Aldwych, London, England*
Branches: Birmingham, Cardiff, Glasgow, Leeds, Manchester, Newcastle-on-Tyne, Southampton, Dublin, Cairo, Johannesburg, Singapore.

Bell Telephone Manufacturing Company *Antwerp, Belgium*
Branches: Berne, The Hague, Brussels, Riga, Reval.

Le Materiel Telephonique *Paris, France*

Telefonos Bell, S. A. *Madrid, Spain*

Western Electric Italiana *Milan, Italy*
Branches: Rome.

Western Electric Norsk Aktieselskap *Christiania, Norway*

Vereinigte Telephon und Telegraphen Fabrik *Vienna, Austria*

United Incandescent Lamps and Electrical Company, Limited
Budapest (Ujpest), Hungary

Western Electric Company (Australia) Limited *Sydney, Australia*
Branches: Melbourne, Wellington.

Nippon Denki Kabushiki Kaisha *Tokyo, Japan*
Branches: Osaka, Dalny (Manchuria), Seoul (Chosen)

Sumitomo Electric Wire & Cable Works, Ltd. *Osaka, Japan*

China Electric Company, Limited *Peking, China*
Branches: Shanghai, Tientsin

Northern Electric Company, Limited *Montreal, Canada*
Branches: Quebec, Halifax, Toronto, London (Ontario), Hamilton, Windsor, Winnipeg, Calgary, Regina, Vancouver

Compania Western Electric Argentina *Buenos Aires, Argentina*

International Western Electric Company *Rio de Janeiro, Brazil*

Sales Offices and Agencies Throughout the World

To those interested in better communication the International Western Electric Company and its Affiliated Companies offer the facilities of their consulting engineering departments to aid in the solution of problems in Telephony Telegraphy and Radio.